

Nov. 26, 1935.

E. H. JÄHNE

2,022,565

APPARATUS FOR CLOSING FOLDED BOXES OR CONTAINERS

Filed Oct. 22, 1931

2 Sheets-Sheet 1

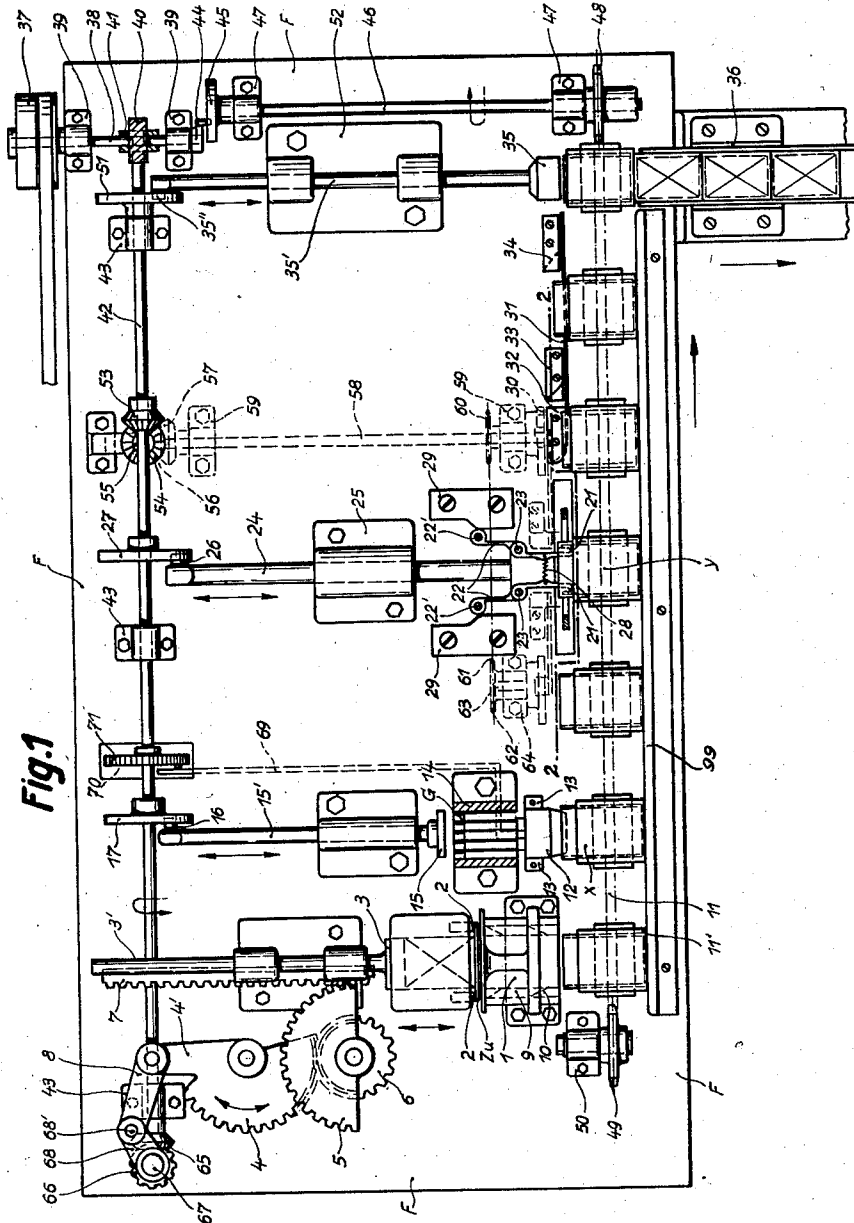

Fig. 1

Inventor:-
Ernst Hermann Jähne
by E. F. Weidert
P.Cy.

Nov. 26, 1935.

E. H. JÄHNE

2,022,565

APPARATUS FOR CLOSING FOLDED BOXES OR CONTAINERS

Filed Oct. 22, 1931

2 Sheets-Sheet 2

Fig. 2

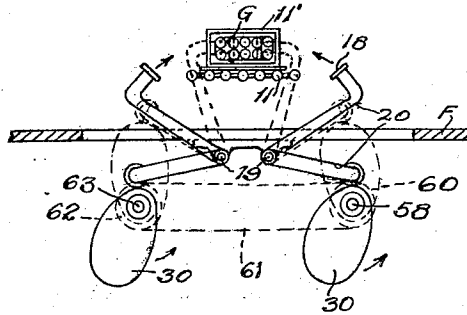

Fig. 4.

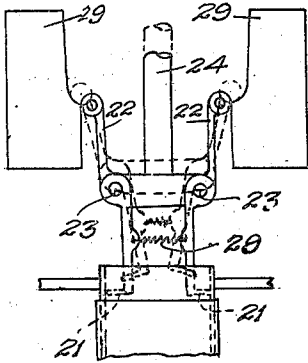

Fig. 3

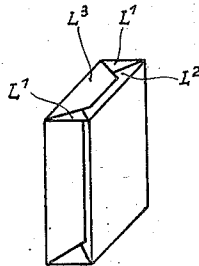
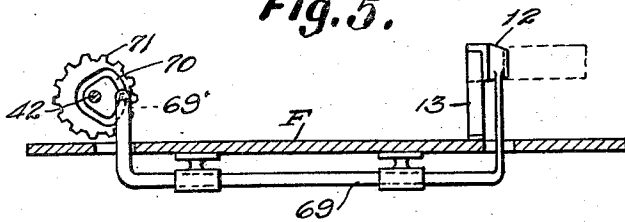

Fig. 5.



Inventor:-
Fürst Hermann Jähne
by E. Plünderoth
Att.

UNITED STATES PATENT OFFICE

2,022,565

APPARATUS FOR CLOSING FOLDED BOXES
OR CONTAINERSErnst Hermann Jähne, Dresden, Germany, as-
signor to "Universelle" Cigarettenmaschinen-
fabrik, J. C. Muller & Co., Dresden, GermanyApplication October 22, 1931, Serial No. 570,487
In Germany November 24, 1930

24 Claims. (Cl. 93—6)

It is known that folded boxes or containers of known type used for packing goods, particularly tobacco goods (cigarettes, smoking tobacco or the like), are first of all completed with the exception of the closing side. After the goods have been introduced, the closing flaps must be inserted at the filling position.

For this purpose it is usual to introduce the filled container into a chamber from which only the closing flaps protrude. These closing flaps are transferred into the closing position by folding-fingers or the like, in which operation either these folding-fingers are actuated, or the chamber is caused to pass by the stationary folding members. In performing this operation it is difficult to fix the scored lines of the closing flaps properly, and moreover damage to the contents of the container or folding box is to be feared—damage which often (as for instance with cigarettes) produces waste goods.

In order to obviate this disadvantage, that is to bring about an absolutely exact bending of the closing flap without the contents of the container being touched, according to this invention, thin flat bars supported by holders are placed on the end to be closed, about which bars the flaps are wrapped; whereupon the flat bars are withdrawn from the folded box, or the folded box is withdrawn from the bars.

For folding the flaps on the narrow side of the package, it is preferable to use actuated folding bars, whereas for folding the broad flaps stationary folding bars are used to which, after the folding of the narrow flaps, the container resting in the chamber is brought, and from which, after the broad flaps have been completely folded, it is withdrawn.

The invention is illustrated in the annexed drawings, in which:—

Fig. 1 is a plan partly in horizontal cross-section.

Fig. 2 is also a plan partly in horizontal cross-section.

Fig. 3 shows the completed article.

Figure 4 is a partial elevational view showing particularly the operation of the article protecting fingers.

Figure 5 is an elevational view with parts in cross section of a detail.

First of all the blank *Zu* of the paper container is brought in known manner in front of a shaping channel 1, and adhesive is applied at the appropriate positions by the gluing rollers 2. Then the shaping plunger 3 is moved in the direction indicated by the arrow in Fig. 1 into the shap-

ing channel 1 by means of the toothed segments 4, 5, the cogwheel 6 and the rack 7. The latter is attached to the shaft 3' of the plunger and the link 8 is pivotally connected to the projection 4' of the segment 4. When the blank is driven through the shaping channel 1, the open container is produced by the known folding members 9 and 10. Now the container-producing apparatus is arranged in relation to the conveyer chain 11 in such manner that the finished container is thrust by the plunger 3 into the receptacle 11' which is held ready on a conveyer chain. When the plunger returns into its initial position the container is retained in the receptacle 11' by known means not shown in the drawings. After one movement the chamber provided with the container passes to the position *x*. Here, first of all the funnel 12 which rests on the guideway 13 is introduced into the open side of the container (see position indicated in Fig. 1). This operation is performed by means of a crank rod 69 which is actuated by a cam roller 69' in cam groove 70 of cam disk 71. This cam disk 71 is mounted on the driving shaft. Then the cigarette group *G* formed in the channel 14 is thrust by the plunger 15 through the funnel 12 into the container. For this purpose a roller 16 is provided on the shaft 15' of the plunger 15, which roller protrudes into a curved groove provided on the face of the disc 17. The guideway 13 of the funnel 12 and the plunger 15 are now driven at such a timed relation, that as soon as the empty container arrives in front of the opening of the funnel this opening is first of all introduced into the open container whereupon the plunger 15 thrusts the cigarette-group *G* into the container and finally the plunger and the funnel return into their initial positions.

Then, after two further movements, the container provided with cigarettes arrives at the position *y*. At this position opposite the filled container there are arranged two folding fingers 18 which are attached respectively to two bell crank levers 20 pivoted at 19. Now before the folding fingers 18 come into operation, two metal bars 21 are introduced into the open folding box, which bars are disposed at right angles at the ends of the two double-arm levers 22. These double-armed levers are arranged parallel to one another and their pivot bolts 23 are mounted on the sliding member 24, which is reciprocated in the guideway 25 in the direction of the receptacles 11. By means of a roller 26, the sliding member 24 engages in the curved groove machined in the face of the cam disc 27. The two

levers 22 are drawn together by a spring 28, but the free ends of the levers are provided with the rollers 22', which owing to the spring tension engage with the cam plates 29. These cam plates 5 are mounted on the machine table F in the same way as the guideway 25 and the other parts already described.

When the sliding member 24 moves in the direction of the receptacles 11', first of all the ends of the lever 22 carrying the flat bars 21 are drawn together by the spring 28. In this position they enter into the part of the folding-container which is still open. When this has taken place, the rollers 22' run over the projections of the cam plates 29. This causes the levers 22 to be swung out into the position shown in Fig. 1 under tension of the spring 28. The sliding member 24 moves forward so far, as shown in Fig. 1, that the flat bars 21 come into position immediately before the ends of the cigarette group G. Now the fingers 18 mounted on the double arm levers 20, being swung out by the cams 30, fold the side flaps (denoted by L' in Fig. 3) over the flat bars 21, so that sharply creased bends are produced, and the sensitive ends of the cigarettes are not crushed or damaged.

After the flaps L' have been folded the sliding member 24 returns to its original position. Then the levers 22 swing inwards so that the flat bars 21 are drawn under the folded flaps and are moved inwards so far that they can be removed beyond the range of the folding member.

When this has taken place, the receptacle 11' passes along in the direction indicated by the arrow in Fig. 1 and comes into the range of a flat bar 31 which is attached, edgewise, to a stationary support 32. On this bar the receptacles 11' pass by in such a manner that the bar rests flat on the opening of the receptacle, namely between the two flaps L² and L³ of the folding box which still protrude. On the further movement of the receptacles first of all the bottom flap L² engages with a folding member 33 arranged behind the bar 31. This folding member folds the flap L² over the bar 31. Thus, here also, a sharply creased bend can be formed, without the ends of the cigarettes being touched during the folding, as the bar 31 at the same time forms a base for the folding operation and on the other hand a protection for the contents of the box.

Now the box moves past an adhesive-applying roller, not shown in the drawings, which provides the lower sides of the flaps L³ with adhesive. Then these flaps come into engagement with a second folding member 34 which folds the flap over the bar and attaches them to the flap L². On the further forward movement of the receptacles 11', they are withdrawn from the bar 31, and the receptacles 11' finally arrive in front of a plunger 35, which moves each container out of the receptacle into a guideway 36, which then passes the articles to a collecting device.

The apparatus is driven by a belt pulley 37 which is mounted on the shaft 38. The shaft 38 is mounted in the bearing 39 attached to the machine table F. On this shaft 38 there is mounted the worm wheel 40 which engages with the worm wheel 41. The latter is mounted on the shaft 42 mounted in the bearing 43. On the shaft 38 is mounted the stop disc 44 which co-operates with the Maltese cross 45. This Geneva stop mechanism imparts intermittent rotation to the shaft 46 on which the Maltese cross 45 is mounted. The shaft 46 is mounted in the bearings

47 and carries one of the sprocket wheels 48 for the chain 11. The other sprocket wheel 49 of the chain 11 is mounted at 50 on the other side of the machine table F.

On the shaft 42 is mounted the disc 51, the face of which is provided with a curved groove. In this curved groove engages the roller 35' which is attached to the plunger rod 35'. The plunger rod 35' is mounted in a guideway 52 attached to the table. Also, on the shaft 42 there is mounted a bevel wheel 53 which co-operates with the bevel wheel 54, which is mounted on a shaft 55 mounted vertically in the machine table F, and the lower end of this shaft carries a further bevel wheel 56. The latter engages with a bevel wheel 57 which is mounted on the shaft 58. The latter is mounted in the bearing 59 fitted under the table F. On the shaft 58 there is mounted a cam 30, and also a sprocket wheel 60 which is connected with a corresponding sprocket wheel 62 by means of the chain 61. The sprocket wheel 62 is mounted on an axle 63, which is mounted in a bearing 64 fitted under the machine table F. On the axle 63 there is mounted another cam 30. Besides the discs 17 and 27, the bevel wheel 55 is also mounted on the shaft 42. This bevel wheel 65 engages with a bevel wheel 66 which is attached to an axle 67, which is mounted vertically in the machine table F, and carries a crank 68, to the crank pins 68' of which the link 8 is articulated.

No special means are provided to hold the boxes in the pockets 11'. The pockets 11' are so constructed that the boxes fit exactly therein so that they cannot be easily removed or shaken therefrom. It will also be noted that all the instrumentalities operating upon the container as for example at the point x, such as the cigarette inserting device and the folding device, constantly tend to press the pockets against the guide bar 99. This guide bar 99 extends parallel to the chain 11 as clearly shown in Figure 1.

Having thus described the nature of the said invention and the best means I know of carrying the same into practical effect, I claim:—

1. In a packaging apparatus means for forming a container from a blank having an open end means for inserting the articles to be packaged through said open end, means for closing said open end and separate means cooperating with said closing means to protect the articles within said container and aid in the creasing of the folds at said open end.

2. A packaging apparatus comprising means for forming a container from a blank having an open end, means for filling said container with articles, folding means for folding the open ends of said container and means cooperating with said folding means inserted within said open end.

3. A wrapping mechanism comprising means for forming a container from a blank having an open end, means for filling said container through said open end, folding fingers for folding the end folds of said open end and means inserted within said open end cooperating with said folding fingers to form sharply creased folds at said end folds.

4. A wrapping mechanism comprising means for forming a container having an open end from a blank, means for filling said container with articles to be wrapped, means for folding the end folds of said open end, means cooperating with said end folding means to form sharply creased end folds, means for folding the side folds of said open end and means cooperating with said side

folding means to form sharply creased side folds.

5. A wrapping mechanism comprising means for forming a container having an open end from a blank, means for filling said container with articles to be wrapped, means for folding the end folds of said open end, means cooperating with said end folding means to protect the articles within said container during the folding of said end fold, means for folding the side folds of said open end and means cooperating with said side folding means to protect the articles within said container during the folding of said side folds.

6. A wrapping mechanism comprising means for forming a container having an open end from a blank, means for filling said container with articles to be wrapped, means for folding the end folds of said open end, means cooperating with said end folding means for sharply creasing said end folds and protecting the articles within said container, means for folding the side folds of said open end and means cooperating with said side folding means for protecting the articles within said container and forming sharply creased folds upon said side folds.

7. A wrapping mechanism comprising means for forming a container having an open end from a blank, means for filling said container with articles to be wrapped, folding fingers for closing portions of said open ends and cam operated means having offset portions cooperating with said folding fingers to form sharply creased folds in said portions folded by said folding fingers.

8. A wrapping mechanism comprising means for forming a container having an open end from a blank, means for filling said container with articles to be wrapped through said open end, folding fingers for closing portions of said open end, cam means for operating said folding fingers and cam operated means having offset portions cooperating with said folding fingers to protect the articles within said container during the folding of said portions of said open end and to form sharply creased folds at said portions folded by said folding fingers.

9. A wrapping mechanism comprising means for forming a container having an open end from a blank, means for inserting into said container through said open end articles to be wrapped, cam operated folding fingers for closing the end folds of said open end, cam operated means cooperating with said folding fingers for protecting the articles within said container during the folding of said end folds, means for folding the side folds of said open end and stationary means cooperating with said side folding means for protecting the articles within said container during the folding of said side folds.

10. A wrapping mechanism comprising means for forming a container having an open end from a blank, means for filling said container with articles to be wrapped through said open end, means for folding the end folds of said open end, means for folding the side folds of said open end and a stationary bar cooperating with said side folding means for protecting the articles within said container during the folding of said side folds.

11. A wrapping mechanism comprising means for forming a container having an open end from a blank, means for filling said container with articles to be wrapped through said open end, means for folding the end folds of said open end, means for folding the side folds of said open end and a stationary bar cooperating with said side fold-

ing means to sharply crease the side folds during the operation of said side folding means.

12. A wrapping mechanism comprising means for forming a container having an open end from a blank, means for filling said container with articles to be wrapped through said open end, means for folding certain folds of said open end and a pair of pivoted members cooperating with said folding means to form sharply creased folds at said folded portions.

13. A wrapping mechanism comprising means for forming a container having an open end from a blank, means for filling said container with articles to be wrapped through said open end, pivoted folding fingers for folding certain portions of said open end, cam members for operating said pivoted folding fingers, a pair of article protecting elements cooperating with said folding fingers during the folding of said portions of said open end and means for inserting said protecting elements within said open end prior to the operation of said folding fingers.

14. A wrapping mechanism comprising means for forming a container having an open end from a blank, means for filling said container through said open end with articles to be wrapped, a reciprocating plunger, protecting elements carried by said plunger adapted to be inserted within said open end in order to protect the articles within said container during the folding of said open end and means for folding said open end.

15. A wrapping mechanism comprising means for forming a container having an open end from a blank, means for filling said container with articles to be wrapped through said open end, a reciprocating plunger, means carried by said reciprocating plunger cooperating with said folding means to protect the articles within said container during the folding and to form sharply creased folds and a stationary bar also cooperating with said folding means to protect the articles within said container during the folding and to form sharply creased folds.

16. A wrapping mechanism comprising means for forming a container having an open end from a blank, means for filling said container through said open end with articles to be wrapped, means for folding the end folds of said open end, a reciprocating plunger, pivoted arms carried by said plunger cooperating with said end folding means to form sharply creased end folds and protect the articles within said container during the folding of said end folds, side folding means for said open end and means cooperating with said side folding means for protecting the articles within said container during the folding of said side folds and to form sharply creased side folds.

17. A wrapping mechanism comprising means for forming a container having an open end from a blank, means for filling said container through said open end with articles to be wrapped, means for folding the end folds of said open end, a reciprocating plunger, pivoted arms carried by said plunger cooperating with said end folding means to form sharply creased end folds and protect the articles within said container during the folding of said end folds, side folding means for said open end and a bar cooperating with said side folding means for protecting the articles within said container during the folding of said side folds and to form sharply creased side folds.

18. A wrapping mechanism comprising an endless chain, pockets carried by said endless chain, a guide bar disposed in proximity to said pockets,

means for forming a container having an open end from a blank and disposing the same in one of said pockets with an end of the container supported by said guide bar, means for intermittently operating said endless chain so as to bring said pockets to rest at a plurality of operating stations, means for filling said container while in said pocket with articles to be wrapped, means for closing the open end of said container while in said pocket, means cooperating with said closing means for protecting the contents of said container during the closing operations and means for discharging said container from said pocket.

19. In a packaging machine end closing means comprising pivoted folding fingers for closing the end folds of a container, a reciprocating plunger and pivoted elements carried by said plunger cooperating with said end closing means to secure sharp folds and to protect the articles within said container.

20. In a wrapping machine end closing means comprising pivoted folding fingers for folding the end folds of the open end of a container, a reciprocating plunger, pivoted protecting elements mounted upon said plunger and adapted to be inserted within the open end of a container to cooperate with said folding fingers to secure sharply creased folds, cam tracks for operating said protecting elements and resilient means maintaining said protecting elements in contact with said tracks.

21. In a wrapping machine end closing means for a container comprising means for closing the end folds of an open end of a container, means cooperating with said end folds closing means to protect the articles within said container and cause sharply creased folds, side folding means and means cooperating with said side closing means to secure sharply creased folds of said

side folds and to protect the articles within said container from the action of said folding means.

22. In a wrapping machine end closing means, comprising end fold closing means, means cooperating with said end fold closing means to secure sharply creased folds and protect the articles within the container, side closing means and a stationary bar cooperating with said side closing means to secure sharply creased side folds and protect the articles within said container.

23. In a wrapping machine end closing means comprising end folds closing means, a reciprocating plunger, pivoted protecting elements carried by said plunger adapted to be inserted within the open end of a container, side closing means means for transferring said container to said side closing means after the end folds have been completed and means cooperating with said side closing means to secure sharply creased side folds and protect the articles within said container.

24. In a wrapping mechanism end closing means comprising pivoted folding fingers for closing the end folds, thin flat bars for cooperating with said folding fingers, pivoted levers upon which said bars are mounted, means for inserting said bars within the open end of a container, means for withdrawing said flat bars from within said container after the folding of the end folds has been completed, stationary folding members for folding the side folds of said open end of said container, means for transferring said container from said end fold closing means to said side closing means, a stationary flat bar cooperating with said stationary folding members to protect the articles within said container during the folding of said side folds and means for removing said container from said end closing means.

ERNST HERMANN JÄHNE.