

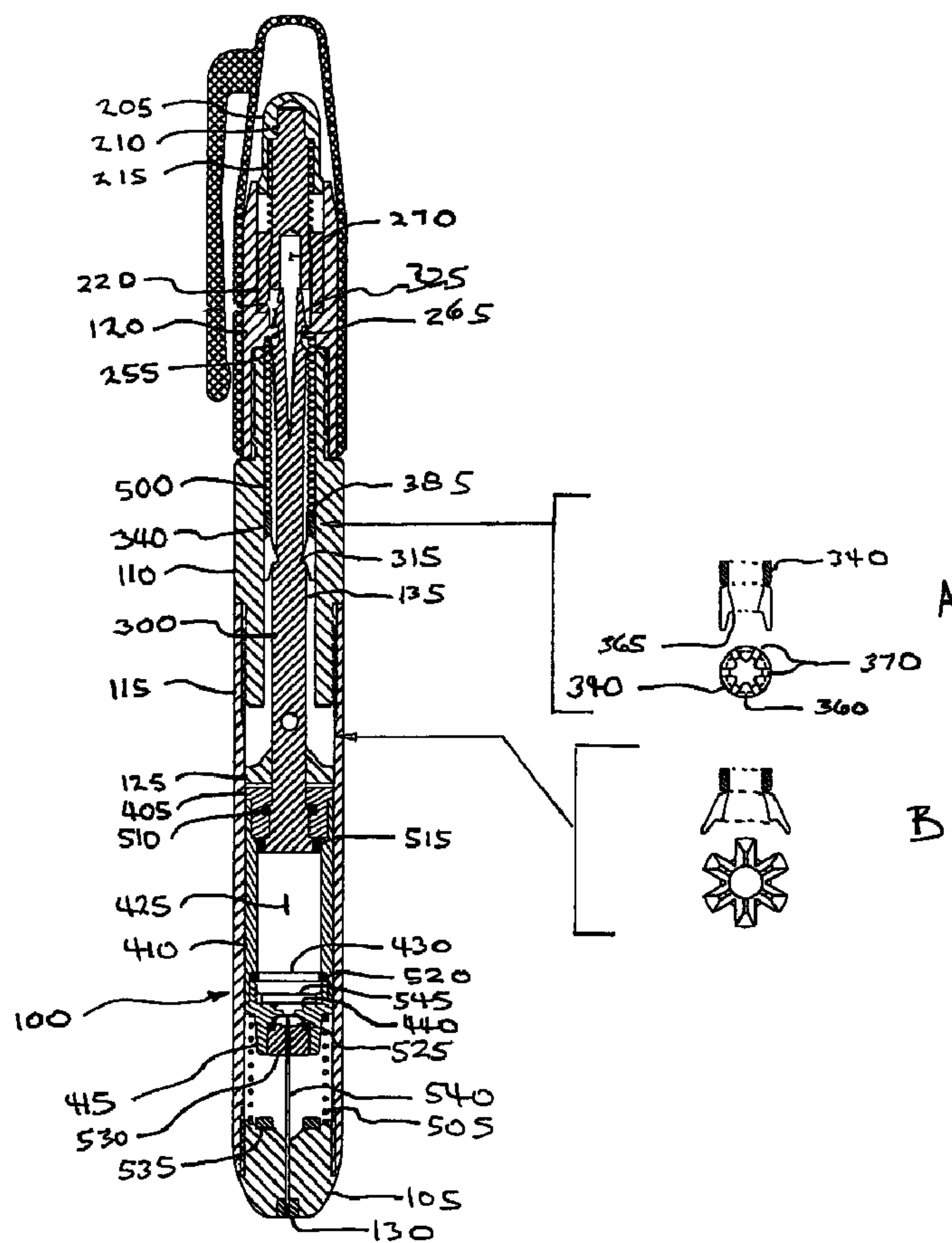

(86) Date de dépôt PCT/PCT Filing Date: 2001/12/21
 (87) Date publication PCT/PCT Publication Date: 2002/06/27
 (45) Date de délivrance/Issue Date: 2009/12/08
 (85) Entrée phase nationale/National Entry: 2003/06/19
 (86) N° demande PCT/PCT Application No.: US 2001/050102
 (87) N° publication PCT/PCT Publication No.: 2002/049691
 (30) Priorité/Priority: 2000/12/21 (US09/745,905)

(51) Cl.Int./Int.Cl. *A61M 5/20* (2006.01)
 (72) Inventeur/Inventor:
 GILLESPIE, RICHARD D., III, US
 (73) Propriétaire/Owner:
 WEST PHARMACEUTICAL SERVICES OF
 DELAWARE, INC., US
 (74) Agent: KIRBY EADES GALE BAKER

(54) Titre : APPAREIL DE MELANGE ET D'INJECTION AUTOMATIQUE
 (54) Title: AUTOMATIC MIXING AND INJECTING APPARATUS



(57) Abrégé/Abstract:

An automatic mixing and injecting apparatus comprises a syringe assembly (400) within a housing (100). The syringe assembly (400) has a chamber (425) for holding a liquid, which can be a liquid medicine or a solvent. A second chamber (460) may hold a

(57) **Abrégé(suite)/Abstract(continued):**

dry medicine. The second chamber (460) is releasably sealed with respect to the first chamber (425). A spring-operated plunger (300) forces liquid from the first chamber (425) and causes the releasable seal (430) to disengage when the needle (540) has entered the recipient. At this time, the liquid flows through the second chamber (460) and dissolves any dry medicine in that chamber (460). A releasable coupling (340) disengages the plunger (300) from the driver spring (500) and allows the plunger (300), syringe assembly (400), and needle (540) to retract under the urging of a return spring (505).

(12) INTERNATIONAL APPLICATION PUBLISHED UNDER THE PATENT COOPERATION TREATY (PCT)

(19) World Intellectual Property Organization
International Bureau



(43) International Publication Date
27 June 2002 (27.06.2002)

PCT

(10) International Publication Number
WO 02/049691 A3

- (51) International Patent Classification⁷: **A61M 5/00**
- (21) International Application Number: PCT/US01/50102
- (22) International Filing Date: 21 December 2001 (21.12.2001)
- (25) Filing Language: English
- (26) Publication Language: English
- (30) Priority Data: 09/745,905 21 December 2000 (21.12.2000) US
- (71) Applicant and
- (72) Inventor: **GILLESPIE, Richard, D., III** [US/US]; 6136 FM 1616, Athens, TX 75751 (US).
- (74) Agent: **THOMAS, John, A.**; Glast, Phillips & Murray, P.C., 13355 Noel Road, Suite 2200, Dallas, TX 75240-6657 (US).
- (81) Designated States (*national*): AE, AG, AL, AM, AT, AU, AZ, BA, BB, BG, BR, BY, BZ, CA, CH, CN, CO, CR, CU, CZ, DE, DK, DM, DZ, EC, EE, ES, FI, GB, GD, GE, GH, GM, HR, HU, ID, IL, IN, IS, JP, KE, KG, KP, KR, KZ, LC, LK, LR, LS, LT, LU, LV, MA, MD, MG, MK, MN, MW, MX, MZ, NO, NZ, PH, PL, PT, RO, RU, SD, SE, SG, SI, SK, SL, TJ, TM, TR, TT, TZ, UA, UG, US, UZ, VN, YU, ZA, ZW.
- (84) Designated States (*regional*): ARIPO patent (GH, GM, KE, LS, MW, MZ, SD, SL, SZ, TZ, UG, ZM, ZW), Eurasian patent (AM, AZ, BY, KG, KZ, MD, RU, TJ, TM), European patent (AT, BE, CH, CY, DE, DK, ES, FI, FR, GB, GR, IE, IT, LU, MC, NL, PT, SE, TR), OAPI patent

[Continued on next page]

(54) Title: AUTOMATIC MIXING AND INJECTING APPARATUS

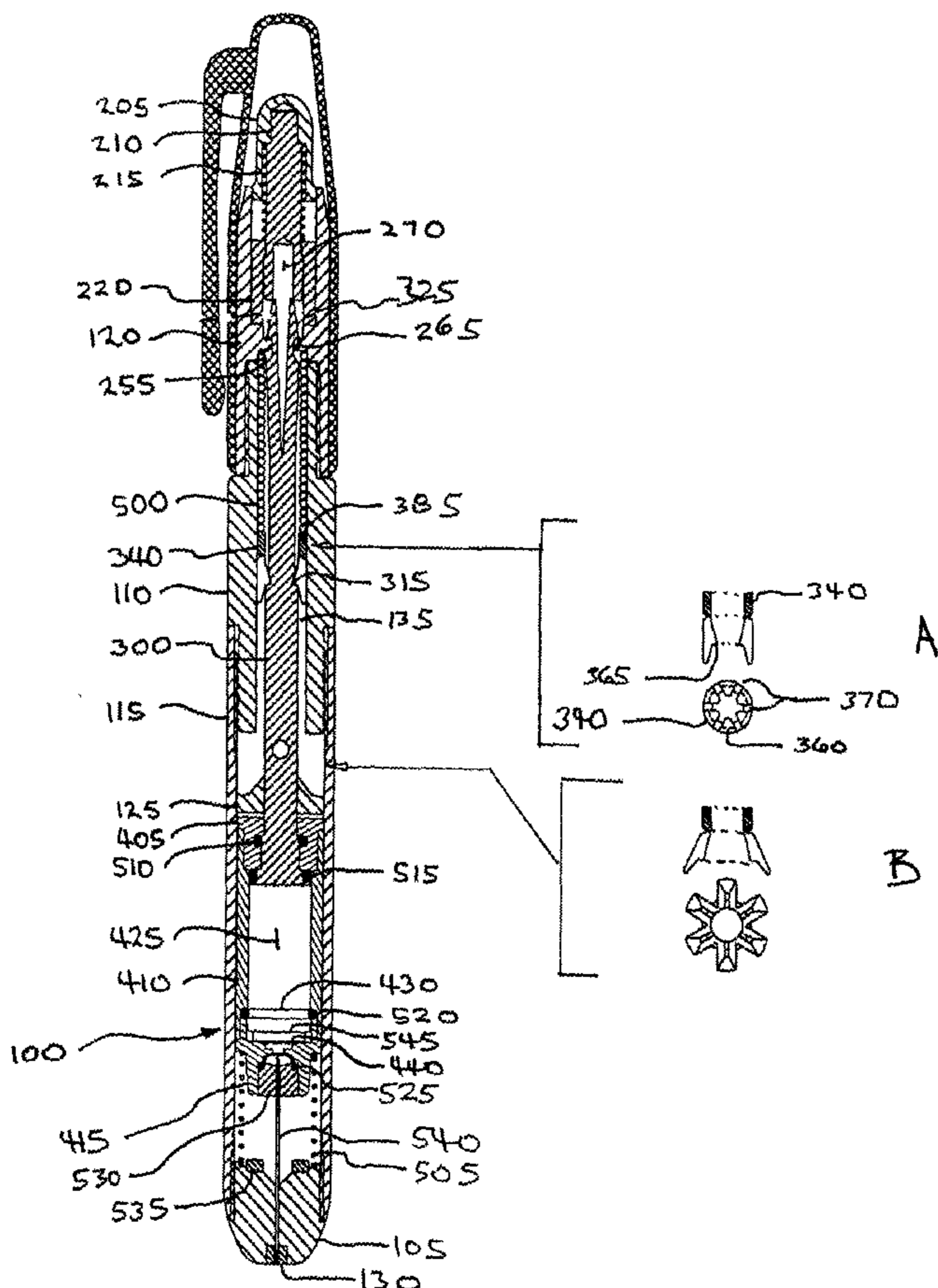

(57) Abstract: An automatic mixing and injecting apparatus comprises a syringe assembly (400) within a housing (100). The syringe assembly (400) has a chamber (425) for holding a liquid, which can be a liquid medicine or a solvent. A second chamber (460) may hold a dry medicine. The second chamber (460) is releasably sealed with respect to the first chamber (425). A spring-operated plunger (300) forces liquid from the first chamber (425) and causes the releasable seal (430) to disengage when the needle (540) has entered the recipient. At this time, the liquid flows through the second chamber (460) and dissolves any dry medicine in that chamber (460). A releasable coupling (340) disengages the plunger (300) from the driver spring (500) and allows the plunger (300), syringe assembly (400), and needle (540) to retract under the urging of a return spring (505).



WO 02/049691 A3

WO 02/049691 A3



(BF, BJ, CF, CG, CI, CM, GA, GN, GQ, GW, ML, MR, NE, SN, TD, TG).

Date of publication of the amended claims: 6 March 2003

Published:

- *with international search report*
- *with amended claims*

For two-letter codes and other abbreviations, refer to the "Guidance Notes on Codes and Abbreviations" appearing at the beginning of each regular issue of the PCT Gazette.

(88) Date of publication of the international search report:

16 January 2003

AUTOMATIC MIXING AND INJECTING APPARATUS1
2
3
4
5
6
7
8
9**TECHNICAL FIELD**

11 The present invention relates to devices pre-loaded with a medicine and intended
12 to automatically administer a pre-determined dose of a liquid medicine by means of an
13 intramuscular, subcutaneous or transdermal injection.

BACKGROUND ART

14
15 In particular, the present invention incorporates a number of important
16 improvements and features as compared to the prior art, including enhanced
17 functionality, convenience, safety and versatility. The present invention also provides a
18 means for quickly administering a pre-determined dose of medication when a need for
19 rapid emergency treatment arises. The present invention may be embodied in a device
20 that can be easily, safely and conveniently carried on the person. The present invention
21 allows a single embodiment that may administer a liquid medicine alone or,
22 alternatively, allow a liquid solvent to automatically mix with a dry medicine upon

1 actuation of the device and concurrent with the injection process. The preferred
2 embodiment automatically renders itself safe for disposal after use and eliminates the
3 risk of injury to others through inadvertent contact with the used hypodermic needle.
4 The recipient before, during, or after the injection, need not even see the hypodermic
5 needle.

6 The use of automatic injection devices has been primarily reserved to
7 emergency, life-sustaining situations. Additional applications for the present invention
8 would be instances where the anatomical site of the injection, such as the penis, make
9 the functional and psychological benefits associated with the use of such a device worth
10 the added cost as compared to the conventional syringes.

11 There are numerous embodiments of automatic injection apparatuses in the prior
12 art, e.g. Wyrick, U.S. Patent No. 5,665,071; Schmitz, No. 5,620,421; and Wilmot, No.
13 5,295,965. None of the prior art patents provide all of the benefits of the present
14 invention, however.

15 **DISCLOSURE OF INVENTION**

16 The present invention pertains to an automatic injection apparatus which injects
17 a single, pre-measured dose of stored medicine intramuscularly or transdermally, and
18 which automatically retracts the hypodermic needle into the device after the injection is
19 completed. In the preferred embodiment, the medicine may comprise either a pre-
20 prepared liquid medicine, a liquid solute that is forced through a dry drug chamber
21 where a soluble medicine is mixed with the solute and carried in solution into the
22 recipient, or a combination of a liquid medicine that also serves as a solute for a dry
23 drug that mixes upon injection.

24 The preferred embodiment has an actuation end and a needle end. For the
25 purposes of this application, the actuation end of the device will be referred to as the
26 proximal end of the device and the needle end will be referred to as the distal end. The
27 user presses the distal end of the device onto the desired injection site and presses the
28 actuation button. This releases the plunger and syringe combination from its temporary
29 engagement with the housing. The plunger and syringe combination is then forced
30 away from the proximal end of the housing by a energized driver spring. The driver
31 spring propels the plunger and syringe combination forward through the bore of the
32 housing until the hypodermic needle exits the housing, and enters the recipient's tissue.

1 During this movement, a return spring positioned between the syringe assembly and the
2 fixed, distal end of the housing becomes compressed and energized. Once the plunger
3 and syringe combination comes to rest against the impact damper pad at the distal end
4 of the housing, the syringe assembly remains stationary and the plunger begins to move
5 axially forward relative to the syringe. As the plunger moves forward, the pressure
6 within the liquid within the syringe begins to rise rapidly until it reaches a critical
7 threshold pressure. Upon reaching the threshold pressure, a rigid disk separating the
8 first liquid chamber from the second dry drug chamber disengages from a
9 circumferential seal holding it into place relative to the syringe. Once separated from
10 the circumferential seal, the disk moves forward until it comes to rest against a retaining
11 surface in the dry drug chamber and the liquid flows through apertures around the disk
12 and into the dry drug chamber.

13 If the dry drug chamber contains a dry medicine, the dry medicine is drawn into
14 solution by the liquid as the plunger continues its forward movement and the liquid is
15 forced through the dry drug compartment and into the entrance to the hypodermic
16 needle. Otherwise, the liquid medicine flows through the same chamber and continues
17 on into the recipient. When the liquid is discharged, the coupling that engages the
18 driver spring and the plunger comes into contact with a splitter which disengages the
19 driver spring from the plunger. Without the influence of the driver spring upon the
20 plunger and syringe combination, the energized return spring forces the plunger and
21 syringe combination to retreat rearward towards the proximal end of the device until the
22 hypodermic needle is fully retracted into the housing.

23 Certain exemplary embodiments may comprise an automatic mixing and
24 injecting apparatus comprising: a housing having a cavity and a proximal and a distal
25 end; a syringe assembly within the housing cavity, the syringe assembly further
26 comprising: a first chamber for holding a liquid; a second chamber for holding a dry
27 medicine, the second chamber disposed distally to the first chamber; the second
28 chamber releasably sealed with respect to the first chamber; a needle, the needle
29 disposed distally of the second chamber; and, a plunger; the plunger having a plunger
30 shaft disposed proximally; the plunger being operable to force the liquid from the first
31 chamber into the second chamber; a spring-to-plunger coupling engaging the plunger

1 shaft and the driver spring; a splitter; the splitter attached to the housing distally to the
2 spring-to-plunger coupling; the splitter further having a surface for engaging the
3 spring-to-plunger coupling and forcing the spring-to-plunger coupling to disengage
4 from the plunger shaft, thereby disengaging the driver spring from the syringe
5 assembly; and a driver spring within the housing, the driver spring engaging the
6 plunger shaft, and operable when released to inject the needle and displace the liquid
7 from the first chamber, through the second chamber and through the needle.

8 **BRIEF DESCRIPTION OF THE DRAWINGS**

9 Figure 1 is a cross-sectional view of a preferred embodiment of the preferred
10 embodiment in a state of readiness. Fig. 1A shows the spring-plunger coupling in its
11 initial, unexpanded state. Fig. 1B shows the spring-to-plunger coupling in its expanded
12 state.

13 Figure 2 provides additional details of the housing and plunger, syringe, and
14 needle assemblies. Fig. 2A shows the plunger, syringe and needle assemblies removed
15 from the housing, which is shown in Fig. 2B.

1 Figure 3 provides additional details of the actuation button assembly. Fig. 3A
2 shows the button assembly removed from the housing. Fig. 3B shows the button
3 assembly in place in the housing.

4 Figure 4 describes the device, as the actuation button is compressed and just
5 prior to the initial forward movement of the plunger, syringe, and needle assembly.

6 Figure 5 describes the device as the plunger, syringe, and needle assembly is
7 urged axially into a state where the leading end of the plunger, syringe, and needle
8 assembly comes to rest at the stationary end of the housing and prior to the rigid disk
9 separating from its seal.

10 Figure 6 describes the device as the rigid disk is fully separated from the
11 circumferential seal, the lower drug chamber seal has been penetrated, and as the
12 plunger has commenced its relative movement in relation to the syringe assembly.

13 Figure 7 describes the device when the plunger has moved forward, the injection
14 liquid is almost entirely dispensed, and the leading end of the spring-to-plunger
15 coupling has made contact with the surface of the disengaging element of the housing.

16 Figure 8 describes the device as the spring-to-plunger coupling has fully opened
17 and disengaged from the plunger, and the injection liquid has been entirely dispensed,
18 but before the return spring has forced the plunger, syringe, and needle assembly
19 rearward.

20 Figure 9 describes the device when the injection process had completed, and the
21 plunger, syringe, and needle assembly have fully retracted.

22

23 **BEST MODE FOR CARRYING OUT THE INVENTION**

24 It is important to note that although the following description will be defined in
25 the context of the example of the preferred embodiment, this is for illustrative purposes
26 only. The invention is not so limited and is applicable to all other embodiments as
27 allowed by the claims.

28 Figure 1 shows a cross section of the preferred embodiment of the automatic
29 mixing and injecting apparatus. In this application, “the proximal end” of the apparatus
30 is the end having the actuation button (205), and the “distal end” is the end of the
31 apparatus having the needle (540). The preferred embodiment preferably has a
32 removable cap for preventing accidental triggering, an actuation button (205), an

1 actuation button rod (210), an actuation button return spring (215), an actuation button
2 retainer cap (220), a housing cap (120), a driver spring (500), a spring-to-plunger
3 coupling (340), a housing midsection (110), a plunger (300), a housing tubular section
4 (115), a coupling splitter (125), an upper syringe cap (405), an upper syringe cap seal
5 (510), a plunger seal (515), a liquid medicine, diluent, or solvent, (collectively called “a
6 liquid” (425) hereafter); a syringe barrel (410), a rupture disk (430), a rupture disk seal
7 (520), an optional dry, or lyophilized, medicine (545), a filter (440), a drug chamber
8 lower seal (525), a lower syringe cap (415), a needle hub (530), a needle (540), a syringe
9 return spring (505), an impact damper pad (535), a housing nose (105), and a needle
10 point seal (130). Figure 2 shows the housing (100), which comprises the housing cap
11 (120), housing midsection (110), housing tubular section (115), and the housing nose
12 (105), which are all permanently joined by means of threaded or bonded connections to
13 form the housing (100).

14 Referring to Figure 3, elements (205), (210), (215), (220) and (120) form a
15 permanently assembled actuation button assembly (200). During assembly of the
16 actuation button assembly (200), the actuation button rod (210) enters into axial
17 engagement with the actuation button retainer cap (220) from the distal end of actuation
18 button retainer cap (220). The actuation button rod (210) slidably cooperates with the
19 actuation button retainer cap (220). An exterior radial shoulder (225) exists on the
20 actuation button rod (210) that denotes a sharp reduction in outside diameter. This
21 shoulder cooperates with a radial shoulder (230) that is interior to the actuation button
22 retainer cap (220) and that defines a transition between the major and minor interior
23 diameters of the actuation button retainer cap (220). The actuation button rod exterior
24 radial shoulder (225) abuts against the actuation button retainer cap (220) interior radial
25 shoulder (230) under the influence of the actuation button return spring (215). This
26 limits the axial travel of the actuation button toward the proximal end of the device.

27 After the actuation button rod (210) is assembled with the actuation button
28 retainer cap (220), the actuation button return spring (215) slides over the outside of the
29 actuation button rod (210) from the proximal end and rests against the proximal face
30 (235) of the actuation button retainer cap (220). The actuation button (205) is then
31 permanently affixed, preferably by means of press fit, onto the actuation button rod
32 (210). The actuation button return spring (215) is thus captured in a state of minor

1 compression with its distal end resting upon the proximal face (235) of the actuation
2 button retainer cap (220) and the proximal end resting against the interior shoulder (240)
3 of the actuation button (205). After completing the assembly of these elements (205),
4 (210), (215) and (220), the assembly is then permanently assembled, preferably by
5 means of an interference fit, into the proximal end of the housing cap (120).

6 Following assembly with the housing cap (120), the actuation button (205)
7 slidably cooperates with the interior bore (245) of the housing cap (120) and the
8 actuation button rod (210) slidably cooperates with the interior bore (250) of the
9 actuation button retainer cap (220). When the actuation button (205) is moved axially
10 relative to the housing cap (120) toward the distal end, the actuation button return spring
11 (215) compresses and stores energy. When force against the actuation button (205) is
12 released, the energy stored in the actuation button return spring (215) returns the
13 actuation button (205) and actuation button rod (210) back to a preferred position where
14 the actuation button (205) is extended beyond the proximal end of the housing cap (120)
15 and the shoulder interior radial shoulder of the actuation button rod (210) rests against
16 the interior radial shoulder (230) of the actuation button retainer cap (220).

17 As shown in Figure 1, a driver spring (500) is shown in a fully compressed state.
18 The proximal end of the compressed driver spring (500) rests against an interior face
19 (255) of the housing cap (120). The opposite end of the compressed driver spring (500)
20 rests against the proximal surface (385) of the spring-to-plunger coupling (340). In the
21 preferred embodiment, the driver spring (500) stores mechanical energy, and provides
22 an adequate amount of axial extension, to move, upon actuation of the device, the
23 spring-to-plunger coupling (340), and the plunger (300) with which the spring-to-
24 plunger coupling (340) is engaged, axially towards the distal end of the device. This
25 axial movement continues until the spring-to-plunger coupling (340) contacts, and is
26 spread radially by the coupling splitter (125). The before-and-after states of the spring-
27 to-plunger coupling (340) are shown in Figs. 1A and 1B respectively. In the preferred
28 embodiment, the driver spring (500) retains a residual compressive force at the end of its
29 extension. The driver spring (500) and the spring-to-plunger coupling (340) slidably
30 cooperate with the interior bore (135) of the housing midsection (110).

31 The spring-to-plunger coupling (340) is captured radially between the interior
32 bore (135) of the housing midsection (110) and a circumferential groove (315) of the

1 plunger (300). In the preferred embodiment, the circumferential groove (315) around
2 the plunger (300) accepts a correspondingly shaped radial lip (365) on the interior of the
3 spring-to-plunger coupling (340) that allows the compression force of the driver spring
4 (500) applied to the spring-to-plunger coupling (340) to be transmitted axially to the
5 plunger (300). During assembly, the end of the plunger (300) having the barbs (325) is
6 orientated towards the proximal end of the device. The driver spring (500) is then
7 compressed axially between the housing cap (120) and the spring-to-plunger coupling
8 (340), while being captured within the interior bore (135) of the housing midsection
9 (110). This axial compression continues until the end of the plunger (300) having the
10 barbs (325) contacts the tapered interior surface (260) of the housing cap (120). The
11 plunger (300) of the preferred embodiment is fabricated of a resilient material, which
12 may be metal or plastic, and therefore possesses the capacity for elastic deformation in
13 the barbed region (320). Upon continued compression of the driver spring, the barbs
14 (325) collapse together and pass through an aperture (265) in the housing cap (120) at
15 which time they are elastically deformed. Upon additional compression of the driver
16 spring (500) and further passage of the elastically deformed plunger barbs (325) through
17 the aperture (265) of the housing cap (120), the barbs (325) eventually exit the
18 constraining surface of the housing cap aperture (265). Upon exiting the aperture (265)
19 in a proximal direction, the elastic property of the barbed region (320) allows it to return
20 to its original shape. In the preferred embodiment, the inside diameter of the aperture
21 (265) in the housing cap (120) is slightly smaller than the free distance at the neck (330)
22 of the plunger barbs, thus forming a detent (267) upon which the barbs (325) rest. This
23 insures that the neck (330) of the plunger (300) remains in contact with the aperture
24 surfaces (265) of the housing cap (120), thus insuring the plunger (300) remains
25 centered within the aperture (265) of the housing cap (120) during the device's state of
26 readiness. Once the barbs (325) of the plunger (300) passes through the aperture (265)
27 of the housing cap (120), the driver spring (500) remains in a state of full compression
28 until the actuation button (205) is physically forced towards the distal end of the device.

29 Referring to Figure 4, as the user pushes the actuation button (205) towards the
30 distal end of the device, the interior bore (270) of the actuation button rod (210) engages
31 the tapered surface (345) of the plunger barbs (325). Upon continued movement of the
32 actuation button (205), the actuation button rod (210) collects the barbs (325) within the

1 interior bore (270) of the actuation button rod (210), defeating the natural elastic
2 property of the plunger barbed region (320). As the actuation button (205) approaches
3 the limit of its travel in the distal direction, the plunger barbed region (320) is forced
4 together until an interference with the detent (267) no longer exists. Once the plunger
5 barbs (325) compress and the interference condition between the plunger barbs (325)
6 and the housing cap (120) is eliminated, the fully compressed and energized driver
7 spring (500) is no longer constrained from extending in the distal direction. The driver
8 spring extends and forces the plunger towards the distal end of the device by virtue of
9 the circumferential engagement between the plunger (300) and the spring-to-plunger
10 coupling (340) on which the driver spring (500) acts.

11 As shown in Figure 2, the plunger (300) has barbs (325), a long cylindrical shaft
12 (305) into which a circumferential groove (315) is machined, and a face (310). The
13 barbs (325) have been previously described. The circumferential groove (315)
14 machined around the periphery of the long cylindrical shaft (305) receives the internally
15 directed radial lip (365) on the interior of the spring-to-plunger coupling (340) as
16 previously described. A circumferential groove (335) is machined about the periphery
17 of the face (310) of the plunger (300). This groove is fitted with an elastomeric plunger
18 seal (515) that resides in contact with, and within the interior confines of, a syringe
19 barrel (410). The plunger seal (515) resides in a state of minor compression between the
20 syringe barrel (410) and the circumferential groove (335) of the face of the plunger
21 (300), and slidably cooperates with the interior surface (420) of the syringe barrel (410).
22 The plunger seal (515) is intended to prevent leakage of the liquid (425) past the plunger
23 (300) as the pressure within the syringe barrel (410) increases. In the preferred
24 embodiment, surfaces of the syringe barrel (410) and plunger (300) that are exposed to
25 direct contact with the liquid (425) would be fabricated of, or coated with, inactive
26 materials which are benign to the human body and are non-reactive with the liquid.

27 In the preferred embodiment, the syringe barrel (410) is permanently bonded to
28 an upper syringe cap (405). An upper syringe cap seal (510) resides within an interior
29 circumferential groove (445) of the upper syringe cap (405) and resides in a state of
30 compression while resting against the periphery of the plunger (300). At the distal end
31 of the syringe barrel (410), an elastomeric rupture disk seal (520) resides within a
32 cylindrical counterbored pocket (450) where the rupture disk seal (520) makes

1 circumferential and flat contact with the cylindrical counterbored pocket (450) of the
2 syringe barrel.

3 The flat contact prevents movement of the disk seal (520) if a force in the axial
4 direction towards the proximal end of the device is imposed on the rupture disk seal
5 (520). The inside diameter of the circumferential pocket (450) of the syringe barrel
6 (410) is slightly smaller than the outside diameter of the rupture disk seal (520). The
7 elastomeric rupture disk seal (520) is thus compressed when installed into the
8 counterbored pocket (450) of the syringe barrel (410) and forms a liquid tight seal which
9 prevents the liquid (425) from leaking between the contacting surfaces.

10 During assembly, the syringe barrel (410) and upper syringe cap (405) are
11 permanently joined, preferably by means of an interference fit. The upper syringe cap
12 seal (510) is then installed in the upper syringe cap (405). The plunger (300) and the
13 plunger seal (515) are then assembled with the syringe barrel (410) and the upper
14 syringe cap (405) with the barbs (325) of the plunger (300) entering the syringe barrel
15 (410) from the distal end of the syringe barrel (410). The plunger (300), then moves
16 axially towards the proximal end of the syringe assembly until the plunger (300), abuts
17 against the inside flat surface (455) of the upper syringe cap (405). This condition
18 represents the relationship that exists between the plunger (300) and the syringe
19 assembly (400) when the device is assembled and in a state of readiness for use.

20 Once the plunger (300), the syringe barrel (410) and the upper syringe cap (405)
21 have been assembled, the entire assembly is orientated vertically with the barbs (325) of
22 the plunger (300) pointing down and the open end of the syringe barrel (410) pointing
23 up. The interior of the syringe barrel is then filled with the liquid (425) up to a point
24 generally level with the flat center line of the rupture disk seal (520).

25 Referring to Figure 5 and 6, the rupture disk (430) is a thin, generally disk-
26 shaped, non-porous element fashioned with a circumferential groove (435) about its
27 periphery. This circumferential groove (435) is shaped and dimensioned to achieve a
28 secure and elastic interference fit with the disk seal (520) so that the rupture disk seal
29 (520) fits within the peripheral groove (435) of the rupture disk (430) and achieves a
30 compressive fit with it. During assembly, the rupture disk (430) is secured into a
31 compressive, circumferential fit with the rupture disk seal (520) after the rupture disk
32 seal (520) is mounted into position in its designated location within the distal end of the

1 plunger (300) and syringe (400) assemblies and after the syringe barrel (410) is filled
2 with liquid (425). By securing the rupture disk (430) into place within the interior
3 periphery of the rupture disk seal (520) while the rupture disk seal (520) is confined on
4 its exterior within the counterbored pocket (450) of the syringe barrel (410), the rupture
5 disk (430) and disk seal (520) form a fluid-tight barrier preventing air from entering the
6 liquid while also preventing liquid from escaping the syringe barrel.

7 Once the syringe barrel (410) is loaded with liquid (425) and the rupture disk
8 (430) is assembled with the rupture disk seal (520), the interference fit between the
9 rupture disk exterior and the rupture disk seal interior is adequate to prevent separation
10 of the two under axial loading of the rupture disk until a minimum threshold force is
11 achieved. Assuming the liquid may be generally described as an incompressible fluid,
12 and fluid pressure is applied symmetrically and evenly distributed across the proximal
13 surface of the rupture disk, the internal pressure necessary to separate the rupture disk
14 from the disk seal would be predictable. Once the first chamber is loaded with liquid
15 (425), and the rupture disk (430) is installed, the preferred embodiment may be
16 orientated in any direction.

17 Separation of the rupture disk (430) from the rupture disk seal (520) occurs at a
18 pressure greater than created by the plunger (300) acting upon the liquid (425) during
19 the free acceleration of the plunger (300) and syringe assembly (400) under the
20 influence of a fully energized driver spring (500). Only after the pressure within the
21 liquid exceeds a predictable threshold under the influence of the plunger (300) will the
22 rupture disk (430) separate from the rupture disk seal (520) and the liquid (425) enter
23 the second, dry drug chamber (460).

24 As shown in Figure 5, the lower syringe cap (415) comprises a non-porous
25 element having a proximal cavity to preferably contain a filter (440) and an optional dry
26 or lyophilized medicine (545) and a distal cavity to contain a drug chamber lower seal
27 (525) and a needle hub (530). Once the filter (440) and optional lyophilized medicine
28 (545) are assembled within the proximal cavity of the lower syringe cap (415), the
29 proximal end of the lower syringe cap is fitted within, and is permanently attached to,
30 the distal end of the syringe barrel (410). The lower syringe cap (415) fits within the
31 counter bore in which the rupture disk seal (520) and rupture disk (430) reside. When
32 fully engaged with the syringe barrel (410), the radial surface of the lower syringe cap

1 (415) compresses in the proximal direction against the rupture disk seal (520) and
2 prevents axial movement of the rupture disk seal (520) in the distal direction. The
3 proximal cavity of the lower syringe cap (415) is fashioned to provide a flat surface
4 (465) on which the rupture disk (430) comes to rest when the liquid pressure exceeds the
5 threshold level necessary to separate the rupture disk (430) from engagement with the
6 rupture disk seal (520). The radially disposed interior surface (465) is slightly larger in
7 diameter than outside diameter of the rupture disk (430). At least one aperture (470)
8 across that interior surface (465) is fashioned into the lower syringe cap to allow the
9 liquid to flow past the rupture disk (430) when the rupture disk resides in flat contact
10 with interior surface (465) of the lower syringe cap (415). When the rupture disk (430)
11 resides in this position, the dry drug chamber is effectively divided into a distal portion
12 and a proximal portion, as shown in Figure 5.

13 Referring to Figure 5, a needle (540) is permanently bonded in an axial
14 relationship to a needle hub (530). During final assembly of the syringe (400), an
15 elastomeric drug chamber lower seal (525), which comprises a dome-shaped septum
16 (475) is inserted septum end first into the distal cavity of the lower syringe cap (415) in
17 an axial, proximal direction, until the disk-shaped compression surface of the drug
18 chamber lower seal (525) seats against the receiving surface within the distal cavity of
19 the lower syringe cap (415). Just prior to inserting and seating the drug chamber lower
20 seal (525), the air within the interior of the dry drug chamber (460) (which comprises
21 the space interior to the proximal cavity of the lower syringe cap (415) and enclosed on
22 one end by the rupture disk (430) and on the other end by the drug chamber lower seal
23 (525)), is preferably evacuated.

24 Once the drug chamber lower seal (525) is installed, the needle (540) and needle
25 hub (530) are then inserted, and permanently affixed into, the lower syringe cap (415),
26 so as to sandwich and compress the sealing surface of the drug chamber lower seal (525)
27 between the flat radial surfaces of the lower syringe cap (415) and the needle hub (530).
28 Once assembled, the proximal end of the needle (540) is positioned close to the concave
29 surface of the drug chamber septum (475). While remaining in an evacuated state, the
30 vacuum within the dry drug chamber (460) pulls the septum (475) of the dry drug lower
31 seal (525) to rest against the distal interior surface of the lower syringe cap (415) so that
32 the only surface on which the vacuum pressure acts is that exposed to the aperture

1 leading from the dry drug chamber (460) to the distal cavity of the lower syringe cap
2 (415).

3 Referring to Figures 1 and 5, at the distal end of the preferred embodiment, the
4 sharp, tissue-penetrating distal end (480) of the needle (540) resides interior to, and in
5 close proximity to, the septum of an elastomeric needle point seal (130). The needle
6 point seal (130) comprises a cylindrical body and a hollow cavity sized slightly larger
7 than the outside diameter of the needle that is open on the proximal end and closed by a
8 thin septum on the distal end. The needle point seal (130) is permanently bonded into a
9 receiving cavity at the distal-most end of the housing nose (105). The needle point seal
10 (130) serves to protect the needle (540) from contamination by sources exterior to the
11 device.

12 Again referring to Figures 1 and 5, the syringe return spring (505) is compressed
13 slightly and positioned so that its axis generally aligns with the long axis of the housing
14 (100). The distal end of the syringe return spring (505) rests upon a radially disposed
15 interior surface (140) of the housing nose (105) and radially exterior to the impact
16 damper pad (535). The proximal end of the syringe return spring (505) rests upon a
17 radially oriented surface (145) proximal to the distal end of the lower syringe cap (415).
18 In the absence of influence by the driver spring (500), the syringe return spring (505)
19 urges the plunger (300) and syringe (400) combination proximally away from the
20 housing nose (105) to a home position with the proximal surface of the upper syringe
21 cap (405) resting against the distal surface (380) of coupling splitter (125). Referring to
22 Figure 5, the axial distance between the radially disposed and distally facing surface
23 (145) of the lower syringe cap (415) and the interior surface (140) of the housing nose
24 (105) is slightly greater than the solid height of the syringe return spring (505),
25 measured when the distal surface of the lower syringe cap (415) is at rest upon the
26 impact damper pad (535).

27 Figure 1 shows the interrelationship between the various elements of the
28 preferred embodiment, in a state of readiness. Figures 4 through 9 describe the various
29 states of the device in the order of actuation sequence. Figure 4 shows the device in an
30 actuated state. Figure 4 shows an enlarged detail of the proximal end of the device.
31 Figure 4 shows the actuation button (205) and actuation button rod (210) in an actuated
32 relationship with the energized actuation button return spring (215), the actuation button

1 retainer cap (220), the housing cap (120) and the barbs (325) of the plunger (300). In
2 this view, the actuation button (205) and the actuation button rod (210) are shown at the
3 terminus of their distal travel. Here the barbs (325) of the plunger (300) are shown
4 channeled into the interior bore (270) of the actuation button rod (210).

5 In Figure 4, the barbs of the plunger are shown compressed radially inward by
6 the distal movement of the actuation button (205) and the actuation button rod (210)
7 against the tapered surface (345) of the barbs (325). Axial and distal movement of the
8 actuation button rod (210), which is attached to the actuation button (205), defeats the
9 elastic forces urging the two halves of the barbs (325) of the plunger (300) apart.
10 Continued axial and distal movement of the actuation button (205) and actuation button
11 rod (210) relative to the housing cap (120), under the influence of the force imposed on
12 the actuation button (205) by the user, reduces the physical interference between the
13 plunger barbs (325) and the proximal surface of the aperture (265) in the housing cap
14 (120), until, as the actuation button (205) and actuation button rod (210) approach the
15 limit of their axial travel in the distal direction, the physical interference between the
16 plunger and the housing cap ceases.

17 Figure 4 thus represents the state when the interference between the plunger
18 (300) and housing cap (120) stops, and just before the plunger (300) begins its
19 acceleration in the distal direction, urged by the fully energized driver spring (500).

20 Figure 5 shows the plunger (300) and syringe (400) combination at the end of its
21 travel in the distal direction, where the distal end of the syringe assembly comes to rest
22 against the impact damper pad (535). At this point, the needle (540) is exposed to the
23 furthest extent achievable beyond the distal end of the housing nose (105). As the
24 plunger (300) and syringe (400) combination traverses the distance from its origin to
25 this location, the syringe return spring (505), which is substantially weaker than the
26 driver spring (500), is compressed and gains energy.

27 As the plunger (300) is disengaged from its interference relationship with the
28 housing cap (120), the fully energized driver spring (500), by virtue of its buttress
29 contact at its proximal end with the interior face (255) of the housing cap (120), and its
30 contact at the distal end at the proximal surface (385) of the spring-to-plunger coupling
31 (340), forces the plunger (300) to accelerate in an axial direction away from the
32 buttressed end of the driver spring (500). The spring-to-plunger coupling (340) is

1 captured radially on its exterior by the interior surface of the interior bore (135) of the
2 housing midsection (110), and radially on the interior by its disengagable interference
3 relationship with the plunger groove (315). This cooperative relationship between the
4 spring-to-plunger coupling (340), the housing midsection (110) and the plunger (300)
5 assures the force of the driver spring (500) is directed to the plunger in a purely axial
6 and distal direction and guides the plunger (300) to travel with its center line coincident
7 to the bore of the housing (100).

8 Once the plunger (300) and syringe (400) combination comes to rest upon the
9 impact damper pad (535), the force applied to the plunger (300) by the driver spring
10 (500) by means of the spring-to-plunger coupling (340) causes the pressure within the
11 incompressible liquid (425) to rise rapidly, since the liquid (425) is trapped within the
12 syringe barrel. The pressure within the syringe presses on all surfaces equally. As a
13 result, the radial forces cancel each other and the force applied to the liquid (425) by the
14 face (310) of the plunger (300) is transferred to the proximal surface of the rupture disk
15 (430) residing in fluid contact. This pressure is directed in an axial, distal direction
16 perpendicular to the fluid contact surface.

17 So long as the pressure differential between the proximal side of the rupture disk
18 (430) and the distal side of the rupture disk does not exceed the threshold pressure
19 necessary to dislodge the rupture disk (430) from its circumferential interference
20 engagement with the rupture disk seal (520), the two elements remain engaged. Until
21 the threshold force is exceeded, and the rupture disk separates from the rupture disk seal
22 (520), the force applied to the plunger (300) by the driver spring (500) is applied to the
23 syringe assembly (400) by means of the fluid pressure of the liquid (425) against the
24 rupture disk (430), which in turn acts upon the rupture disk seal (520) that is trapped in
25 axial engagement within the syringe assembly (400). The threshold pressure necessary
26 to dislodge the rupture disk (430) from engagement with the rupture disk seal (520) is
27 made greater than that generated by the plunger (300) acting upon the liquid (425)
28 during the free travel of the syringe assembly (400). By design, the threshold force can
29 only be exceeded once the syringe assembly comes to rest upon the impact damper pad
30 (535) at the end of its allowable travel.

31 Under the influence of the plunger (300) upon the liquid (425) and the resistance
32 to the imposed force by the securely-engaged rupture disk (430), the plunger (300), and

1 syringe assembly (400) move in tandem in the distal direction. As the syringe assembly
2 (400) begins to move, the distal end (480) of the needle (540) punctures the needle point
3 seal (130) and enters the flesh at the injection site. Figure 5 shows the preferred
4 embodiment in a state where the needle (540) is fully extended as the syringe assembly
5 (400) contacts the impact damper pad (535) and just prior to the rupture disk (430)
6 separating from engagement with the rupture disk seal (520).

7 As described in Figure 6, once the fluid pressure acting upon the rupture disk
8 (430) of the preferred embodiment by the liquid (425) exceeds the threshold amount, the
9 rupture disk (430) disengages from its circumferential interference relationship with the
10 rupture disk seal (520) and moves distally a short distance into physical contact with a
11 proximally-facing surface (465) of the lower syringe cap (415) within the proximal
12 cavity of the lower syringe cap (415). The supporting surface (465) of the lower syringe
13 cap (415) has an aperture (470) in at least one location, and preferably several locations,
14 to allow the liquid (425) to flow around the rupture disk (430) and into the distal portion
15 of the dry drug chamber (460) where, if the application calls for it, a dry medicine (545)
16 resides.

17 Once the rupture disk (430) separates from the rupture disk seal (520) and the
18 liquid (425) begins to flood the dry drug chamber (460), the vacuum being maintained
19 within that compartment is broken and the volume within the unit is filled with the
20 liquid (425). If therapeutic application calls for its use, the dry, highly soluble, medicine
21 (545) residing within the dry drug chamber (460) would come into contact with the
22 liquid (425) and rapidly begin to dissolve. Once the entire volume of the dry drug
23 chamber (460) is filled with liquid (425), the pressure rises rapidly under the influence
24 of the plunger (300) moving distally within the syringe barrel (410) and pressing upon
25 the liquid (425). As the pressure rises within the dry drug chamber (460), the pressure
26 of the liquid (425) causes the septum (475) of the drug chamber lower seal (525), to
27 deflect distally.

28 As the septum (475) begins to deflect, it pulls away from the interior surface of
29 the lower syringe cap (415) upon which it normally resides, and the surface area of the
30 septum (475) exposed to the liquid expands. This increased surface area allows for an
31 increasing force to act upon the septum (475), which in turn accelerates the distal
32 deflection. The septum (475) eventually begins to invert as depicted in Figure 6 and

1 comes into penetrating contact with the proximal end of the needle (540), which is
2 preferably beveled to facilitate penetration of the septum (475). When the pressure
3 imposed upon the septum (475) of the drug chamber lower seal (525) exceeds a
4 threshold, the septum (475) becomes fully penetrated by the stationary and securely
5 fixed beveled end of the needle (540) and the liquid (425), possibly mixed with a dry
6 medicine (545), begins to flow out of the needle (540) and into the recipient of the
7 injection.

8 Figure 6 depicts the preferred embodiment in a state where the rupture disk (430)
9 is separated from engagement with the rupture disk seal (520), the dry drug chamber
10 (460) within the lower syringe cap (415) is flooded with liquid medicine, the drug
11 chamber septum (475) has been inverted and penetrated by the proximal end of the
12 needle (540) and the plunger (300) is advancing distally causing the liquid medicine to
13 flow through the needle (540) and into the recipient.

14 Referring to Figure 7, as the plunger (300) of the preferred embodiment
15 continues to move distally under the influence of the driver spring (500) by means of the
16 spring-to-plunger coupling (340), the liquid medicine is expelled from the syringe
17 assembly (400) through the needle (540) and into the recipient. As the plunger (300)
18 approaches the distal end of the syringe barrel (410), the distal end (350) of the spring-
19 to-plunger coupling (340) approaches the proximal end of the surface (355) of the
20 coupling splitter (125). This surface (355) is generally sloping from the plunger shaft
21 (305) to a lesser thickness; it may, for example, have a conical cross-section. Figure 7
22 describes the state where the volume of liquid (425) dispensed is approaching the
23 volume of the intended dose and spring-to-plunger coupling (340) has initiated contact
24 with the coupling splitter (125).

25 Referring to Figures 1 and 8, as the injection process nears its conclusion, the
26 plunger (300) of the preferred embodiment continues to move distally under the
27 influence of the driver spring (500) by means of the spring-to-plunger coupling (340)
28 and the distal end (350) of the spring-to-plunger coupling (340) begins to ride over the
29 sloping surface (355) of the coupling splitter (125). The spring-to-plunger coupling
30 (340) is fabricated to include a plurality of axial slits (370) that are equally spaced
31 around its periphery and extend from the distal end to a circumferential groove (360)
32 around the spring-to-plunger coupling (340). The circumferential groove (360) serves

1 to allow for easy flexure of the slotted portion of the spring-to-plunger coupling (340) in
2 the radial direction at a known and axially consistent fulcrum point. The driver spring
3 forces the distal portion (370) of the spring-to-plunger coupling (340) to ride over the
4 surface (355) of the coupling splitter (125). As the slotted portion of the spring-to-
5 plunger coupling (340) begins to open into a rosette pattern in a sliding relation to the
6 sloping surface (355) of the coupling splitter (125), the degree of dimensional
7 interference between the radial lip (365) of the spring-to-plunger coupling (340) and the
8 corresponding groove (315) around the periphery of the plunger (300) diminishes until
9 the engagement between the plunger (300) and the expanded spring-to-plunger coupling
10 (375) ceases altogether.

11 Figure 8 describes the state where substantially the entire volume of the liquid
12 (425) has been dispensed, and spring-to-plunger coupling (340) has disengaged entirely
13 from contact with the plunger (300). The driver spring (500) therefore has no further
14 influence on the plunger (300) by way of the spring-to-plunger coupling (340). The
15 interior bore (395) of the spring-to-plunger coupling proximal to the groove (360) is
16 dimensioned to provide an easy slip fit with the shaft (305) of the plunger (300) once the
17 interference relationship between the spring-to-plunger coupling (340) and the plunger
18 (300) is terminated. The flow of medicine out of the syringe barrel (410) ends upon
19 disengagement of the spring-to-plunger coupling (340) from the plunger (300). The
20 plunger (300) and syringe (400) combination is now influenced only by the energized
21 syringe return spring (505) acting upon the distally facing surface (145) of the lower
22 syringe cap (415). Figure 8 represents the state when the spring-to-plunger coupling has
23 become disengaged from the plunger, and the flow of liquid out of the device has
24 ceased, but the emptied plunger (300) and syringe (400) combination has yet to respond
25 to the influence of the energized syringe return spring (505).

26 As depicted in Figure 9, once the spring-to-plunger coupling (340) has been
27 flared outward by its involvement with the coupling splitter (125) so as to end its
28 engagement with the plunger (300), and the plunger (300) is therefore no longer urged
29 distally by the driver spring (500), the energized syringe return spring (505) acts upon
30 the lower syringe cap (415), and forces the plunger (300) and syringe (400) combination
31 in a proximal direction. The plunger (300) and syringe (400) combination continues to
32 accelerate in the proximal direction until the proximal surface of the upper syringe cap

1 (405) contacts the distal surface (380) of the coupling splitter (125) at which time the
2 distal end (480) of the needle (540) is fully retracted into the housing nose (105). The
3 syringe return spring (505) remains in a moderately biased and energized state upon full
4 retraction of the plunger (300) and syringe (400) combination.

5 The device is thus rendered harmless because there is no risk of exposure to the
6 used hypodermic needle and the blood-borne diseases that may be transmitted through
7 contaminated hypodermic needles. The device may then be disposed of by conventional
8 means without risk of injury or infection to others who may come into contact with it.
9 Figure 9 thus represents the terminal state of the preferred embodiment after the
10 injection process has been completed, the needle has been fully retracted, and the device
11 has been rendered safe for disposal.

12 I claim:

The embodiments of the invention in which an exclusive property or privilege is claimed are defined as follows:

1. An automatic mixing and injecting apparatus comprising:
 - a. a housing having a cavity and a proximal and a distal end;
 - b. a syringe assembly within the housing cavity, the syringe assembly further comprising:
 - (1) a first chamber for holding a liquid;
 - (2) a second chamber for holding a dry medicine, the second chamber disposed distally to the first chamber; the second chamber releasably sealed with respect to the first chamber;
 - (3) a needle, the needle disposed distally of the second chamber; and,
 - (4) a plunger; the plunger having a plunger shaft disposed proximally; the plunger being operable to force the liquid from the first chamber into the second chamber;
 - (5) a spring-to-plunger coupling engaging the plunger shaft and the driver spring;
 - (6) a splitter; the splitter attached to the housing distally to the spring-to-plunger coupling; the splitter further having a surface for engaging the spring-to-plunger coupling and forcing the spring-to-plunger coupling to disengage from the plunger shaft, thereby disengaging the driver spring from the syringe assembly; and,
 - c. a driver spring within the housing, the driver spring engaging the plunger shaft, and operable when released to inject the needle and displace the liquid from the first chamber, through the second chamber and through the needle.

2. The automatic mixing and injecting apparatus of claim 1, where the plunger shaft further comprises a circumferential groove; and, the spring-to-plunger coupling further comprises:
 - a. a plurality of axial slits; and,
 - b. a radial lip for releasably engaging the circumferential groove, so that the radial lip disengages from the circumferential groove as the spring-to-plunger coupling engages the splitter.

3. The automatic mixing and injecting apparatus of claim 1, further comprising:
 - a. a disk releasably sealing the first chamber from the second chamber; and,
 - b. at least one aperture in the wall of the second chamber allowing liquid communication between the portion of the second chamber proximal to the released disk and the portion of the second chamber distal to the released disk, so that the liquid flows through the second chamber before being forced through the needle.

4. The automatic mixing and injecting apparatus of claim 1, further comprising a return spring; the return spring disposed between the housing and the syringe assembly; the return spring urging the syringe assembly proximally.

5. The automatic mixing and injecting apparatus of claim 1, further comprising:
 - a. at least two compressible barbs; the barbs connected to the proximal end of the plunger shaft;
 - b. the housing having a housing cap;
 - c. a rod moveably disposed within the housing cap; the rod having an interior bore sized to receive the barbs in their compressed state; and,
 - d. a detent integral with the housing cap; the detent sized to engage the barbs in their uncompressed state and prevent the distal movement of the plunger shaft until the barbs are compressed.

6. The automatic mixing and injecting apparatus of claim 1 further comprising a flexible septum; the flexible septum disposed proximally to the proximal end of the needle and sealing the needle from the second chamber; so that liquid pressure in the second chamber causes the septum to deflect distally until the septum is penetrated by the proximal end of the needle.

7. An automatic mixing and injecting apparatus comprising:
- a. a housing having a cavity and a proximal and a distal end;
 - b. a syringe assembly within the housing cavity, the syringe assembly further comprising:
 - (1) a first chamber for holding a liquid;
 - (2) a second chamber; the second chamber disposed distally to the first chamber;
 - (3) a disk releasably sealing the first chamber from the second chamber;
 - (4) a needle disposed distally of the second chamber;
 - (5) a plunger; the plunger having a plunger shaft disposed proximally; the plunger being operable to force the liquid from the first chamber and cause the disk to release;
 - (6) a spring-to-plunger coupling engaging the plunger shaft and the driver spring;
 - (7) a splitter; the splitter attached to the housing distally to the spring-to-plunger coupling; the splitter further having a surface for engaging the spring-to-plunger coupling and forcing the spring-to-plunger coupling to disengage from the plunger shaft, thereby disengaging the driver spring from the syringe assembly; and,
 - c. a least one aperture in the wall of the second chamber allowing liquid communication between the portion of the second chamber proximal to the released disk and the portion of the second chamber distal to the released disk, so that the liquid flows through the second chamber before being forced through the needle.

8. The automatic mixing and injecting apparatus of claim 7, where the plunger shaft further comprises a circumferential groove; and, the spring-to-plunger coupling further comprises:

- a. a plurality of axial slits; and,
- b. a radial lip for releasably engaging the circumferential groove, so that the radial lip disengages from the circumferential groove as the spring-to-plunger coupling engages the splitter.

9. The automatic mixing and injecting apparatus of claim 7, further comprising a driver spring within the housing, the driver spring engaging the plunger shaft and operable when released to inject the needle and displace the liquid past the released disk, through the second chamber and through the needle.

10. The automatic mixing and injecting apparatus of claim 7, further comprising a return spring; the return spring disposed between the housing and the syringe assembly; the return spring urging the syringe assembly proximally when the driver spring is disengaged from the syringe assembly.

11. The automatic mixing and injecting apparatus of claim 7, further comprising:

- a. at least two compressible barbs; the barbs connected to the proximal end of the plunger shaft;
- b. the housing having a housing cap;
- c. a rod disposed within the housing cap; the rod having an interior bore sized to receive the barbs in their compressed state; and,
- d. a detent integral with the housing cap; the detent sized to engage the barbs in their uncompressed state and prevent the distal movement of the plunger shaft until the barbs are compressed.

12. The automatic mixing and injecting apparatus of claim 7 further comprising a flexible septum; the flexible septum disposed proximally to the proximal end of the needle and sealing the needle from the second chamber; so that liquid pressure in the second chamber causes the septum to deflect distally until it is penetrated by the proximal end of the needle.

13. An automatic injecting apparatus comprising:

a. a housing having a cavity and a proximal and a distal end;

b. a syringe assembly within the housing, the syringe assembly further comprising:

(1) a first chamber for holding a liquid;

(2) a needle; and,

(3) a plunger, the plunger having a plunger shaft disposed proximally, the plunger being operable to force the liquid from the first chamber;

c. the plunger shaft engaging a spring-to-plunger coupling;

d. a driver spring within the housing, engaging the spring-to-plunger coupling, operable to the syringe assembly to inject the needle and displace the liquid medicine through the needle; and,

e. a splitter attached to the plunger shaft distally to the spring-to-plunger coupling; the splitter having a surface for engaging the spring-to-plunger coupling and forcing the spring-to-plunger coupling to disengage from the plunger shaft, thereby disengaging the driver spring from the syringe assembly.

14. The automatic injecting apparatus of claim 13, where the plunger shaft further comprises a circumferential groove; and, the spring-to-plunger coupling further comprises:

a. a plurality of axial slits; and,

b. a radial lip for releasably engaging the circumferential groove, so that the radial lip disengages from the circumferential groove as the spring-to-plunger coupling engages the splitter.

15. The automatic injecting apparatus of claim 13, further comprising:
- a. a second chamber for holding a liquid;
 - b. a disk disposed between the first chamber and the second chamber; the disk releasably sealing the first chamber from the second chamber; and,
 - c. a least one aperture in the wall of the second chamber allowing liquid communication between the portion of the second chamber proximal to the disengaged disk and the portion of the second chamber distal to the disengaged disk, so that the liquid flows through the second chamber before being forced through the needle.
16. The automatic injecting apparatus of claim 13, further comprising a return spring; the return spring disposed between the housing and the syringe assembly; the return spring urging the syringe assembly proximally when the driver spring is disengaged from the syringe assembly.
17. The automatic mixing and injecting apparatus of claim 13, further comprising:
- a. at least two compressible barbs; the barbs connected to the proximal end of the plunger shaft;
 - b. the housing having a housing cap;
 - c. a rod disposed within the housing cap; the rod having an interior bore sized to receive the barbs in their compressed state; and,
 - d. a detent integral with the housing cap; the detent sized to engage the barbs in their uncompressed state and prevent the distal movement of the plunger shaft until the barbs are compressed.
18. The automatic mixing and injecting apparatus of claim 13 further comprising a flexible septum; the flexible septum disposed proximally to the proximal end of the needle and sealing the needle from the second chamber; so that liquid pressure in the chamber causes the septum to deflect distally until the septum is penetrated by the proximal end of the needle.

19. An automatic mixing and injecting apparatus comprising:
- a. a housing having a cavity and a proximal and a distal end;
 - b. a syringe assembly within the housing cavity, the syringe assembly further comprising:
 - (1) a first chamber for holding a liquid;
 - (2) a second chamber for holding a dry medicine, the second chamber disposed distally to the first chamber;
 - (3) a disk releasably sealing the first chamber from the second chamber;
 - (4) a needle, the needle disposed distally of the second chamber;
 - (5) a plunger; the plunger having a plunger shaft disposed proximally; the plunger being operable to force the liquid from the first chamber into the second chamber;
 - (6) at least one aperture in the wall of the second chamber allowing liquid communication between the portion of the second chamber proximal to the released disk and the portion of the second chamber distal to the released disk, so that the liquid flows through the second chamber before being forced through the needle;
 - c. a driver spring within the housing, the driver spring engaging the plunger shaft, and operable when released to inject the needle and displace the liquid from the first chamber, through the second chamber and through the needle;
 - d. a spring-to-plunger coupling engaging the plunger shaft and the driver spring;
 - e. a splitter; the splitter attached to the housing distally to the spring-to-plunger coupling; the splitter further having a surface for engaging the spring-to-plunger coupling and forcing the spring-to-plunger coupling to disengage from the plunger shaft, thereby disengaging the driver spring from the syringe assembly;
 - f. the plunger shaft further comprising a circumferential groove; and, the spring-to-plunger coupling further comprising:
 - (1) a plurality of axial slits; and,

(2) a radial lip for releasably engaging the circumferential groove, so that the radial lip disengages from the circumferential groove as the spring-to-plunger coupling engages the splitter;

g. at least two compressible barbs; the barbs connected to the proximal end of the plunger shaft;

h. a rod axially moveable within the housing; the rod having an interior bore sized to receive the barbs in their compressed state; and,

i. a detent integral with the housing; the detent sized to engage the barbs in their uncompressed state and prevent the distal movement of the plunger shaft until the barbs are compressed;

j. a return spring; the return spring disposed between the housing and the syringe assembly; the return spring urging the syringe assembly proximally; and,

k. a flexible septum; the flexible septum disposed proximally to the proximal end of the needle and sealing the needle from the second chamber; so that liquid pressure in the second chamber causes the septum to deflect distally until it is penetrated by the proximal end of the needle.

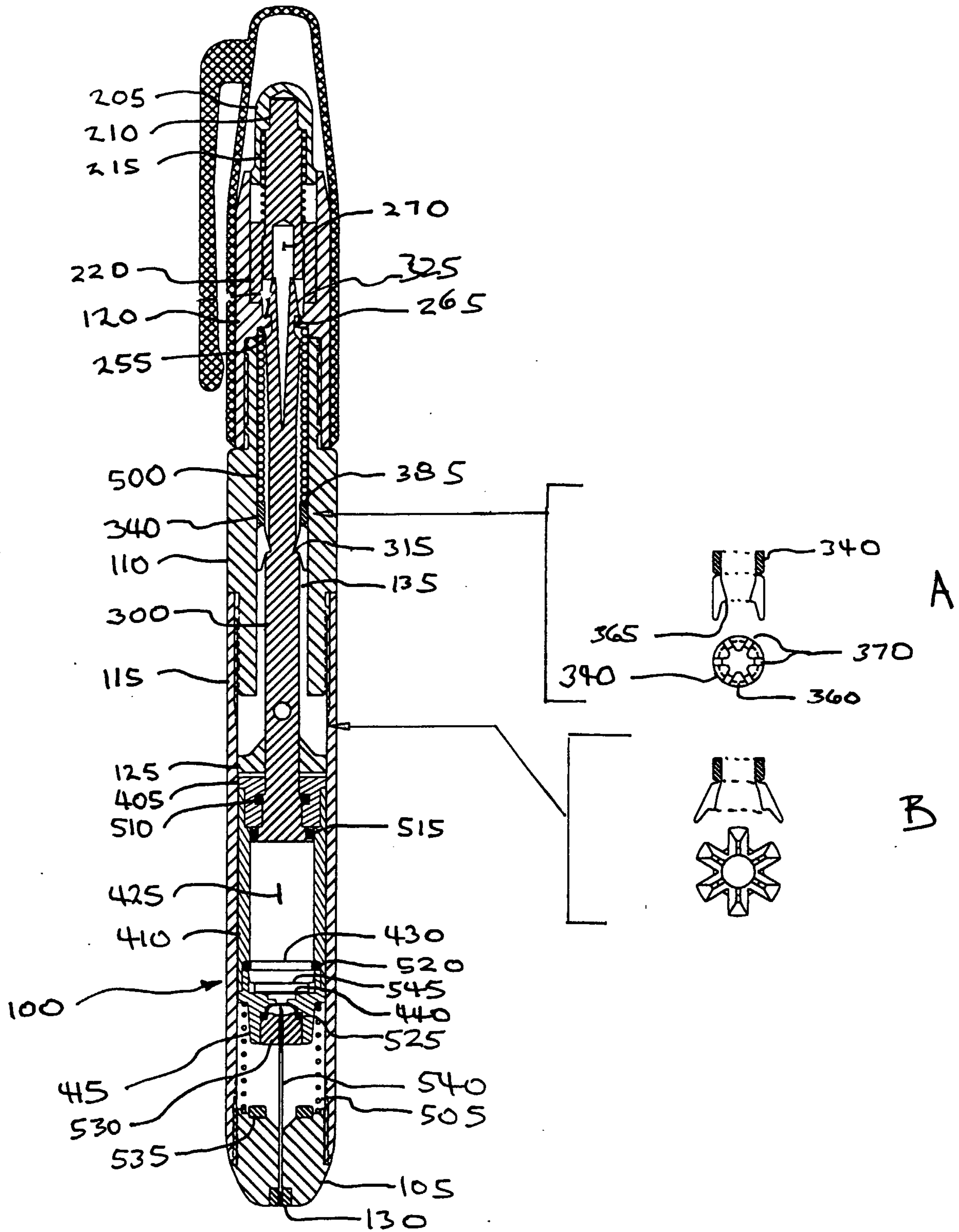

FIG. 1

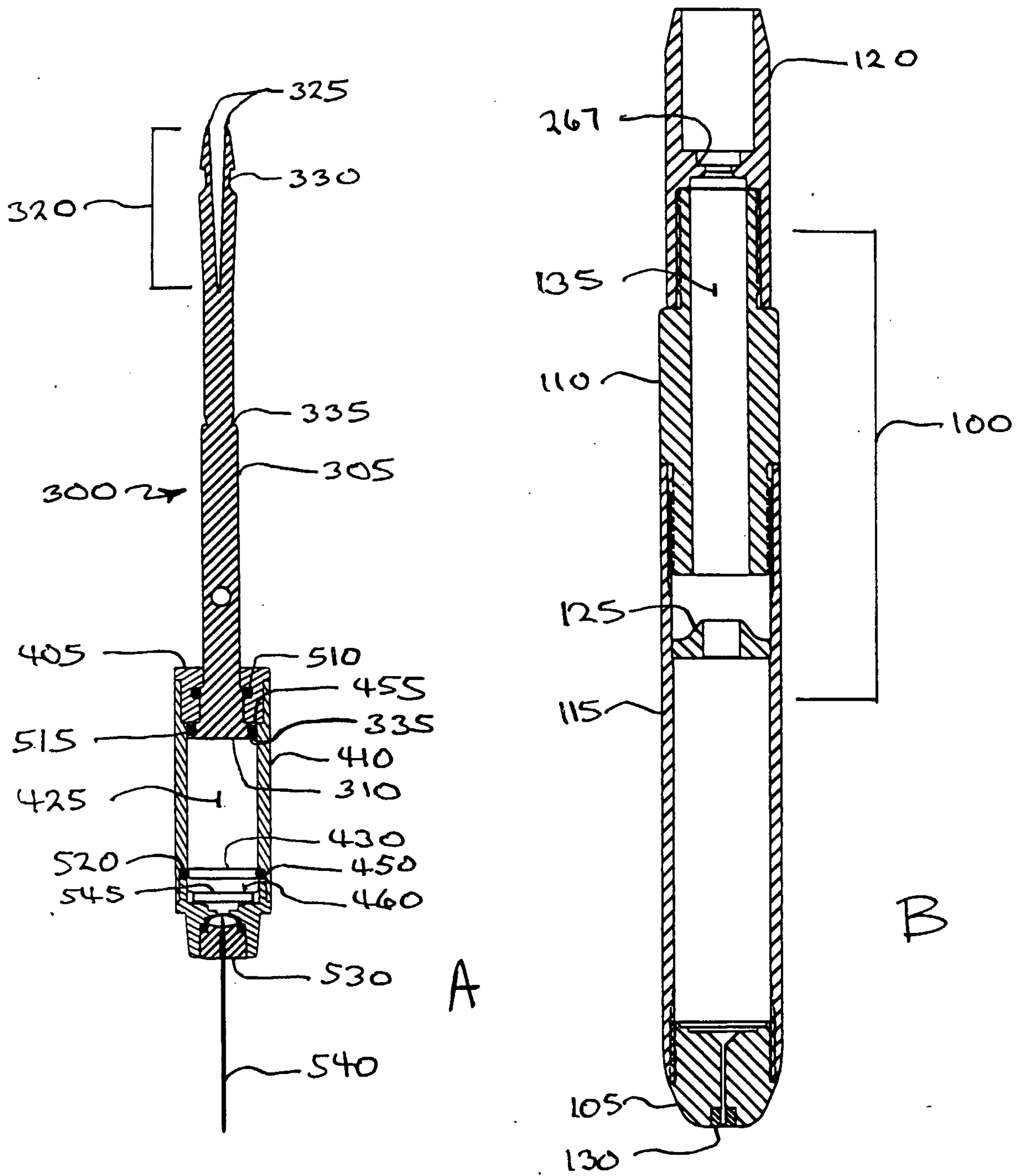

FIG. 1

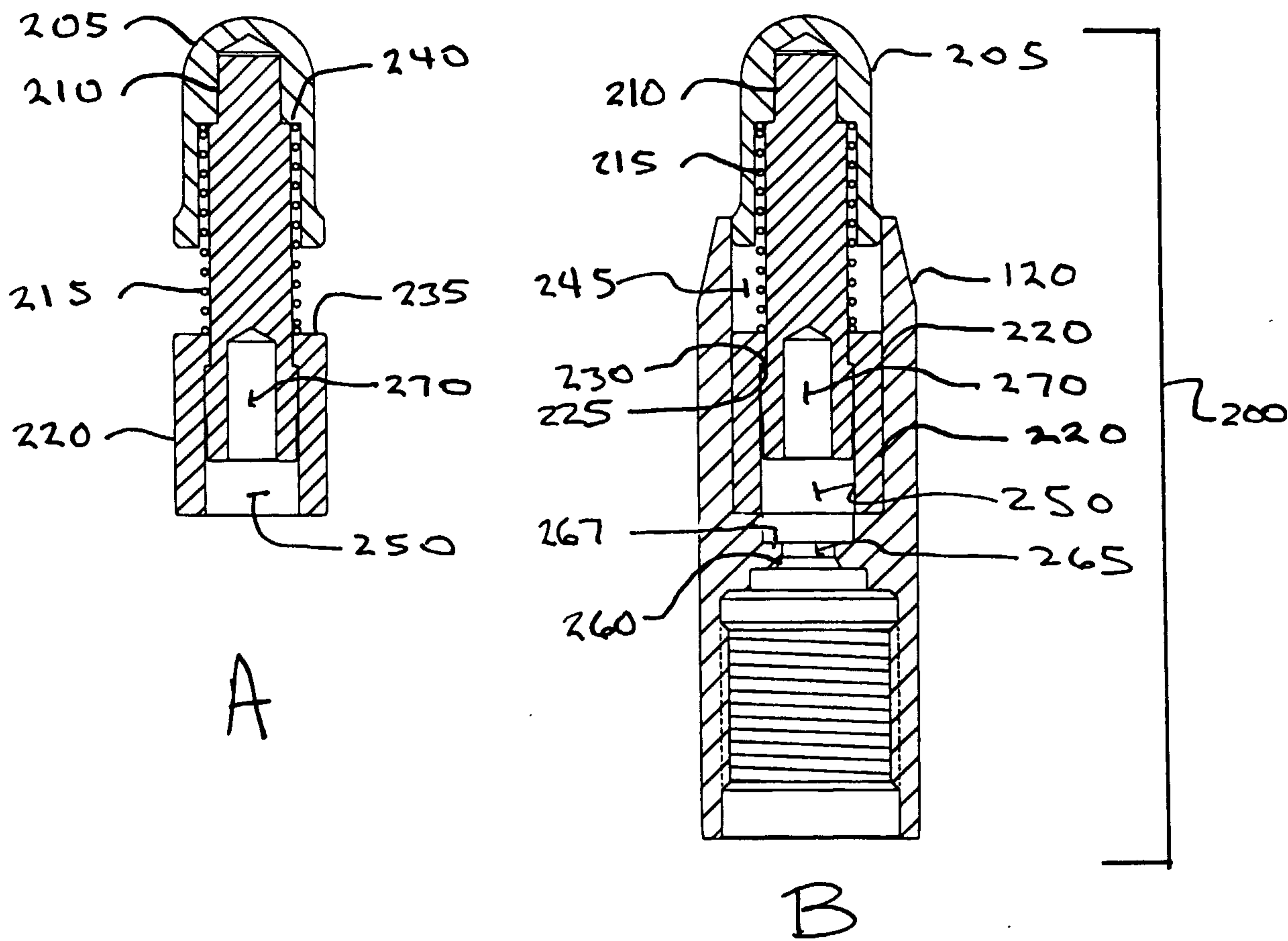

FIG. 3

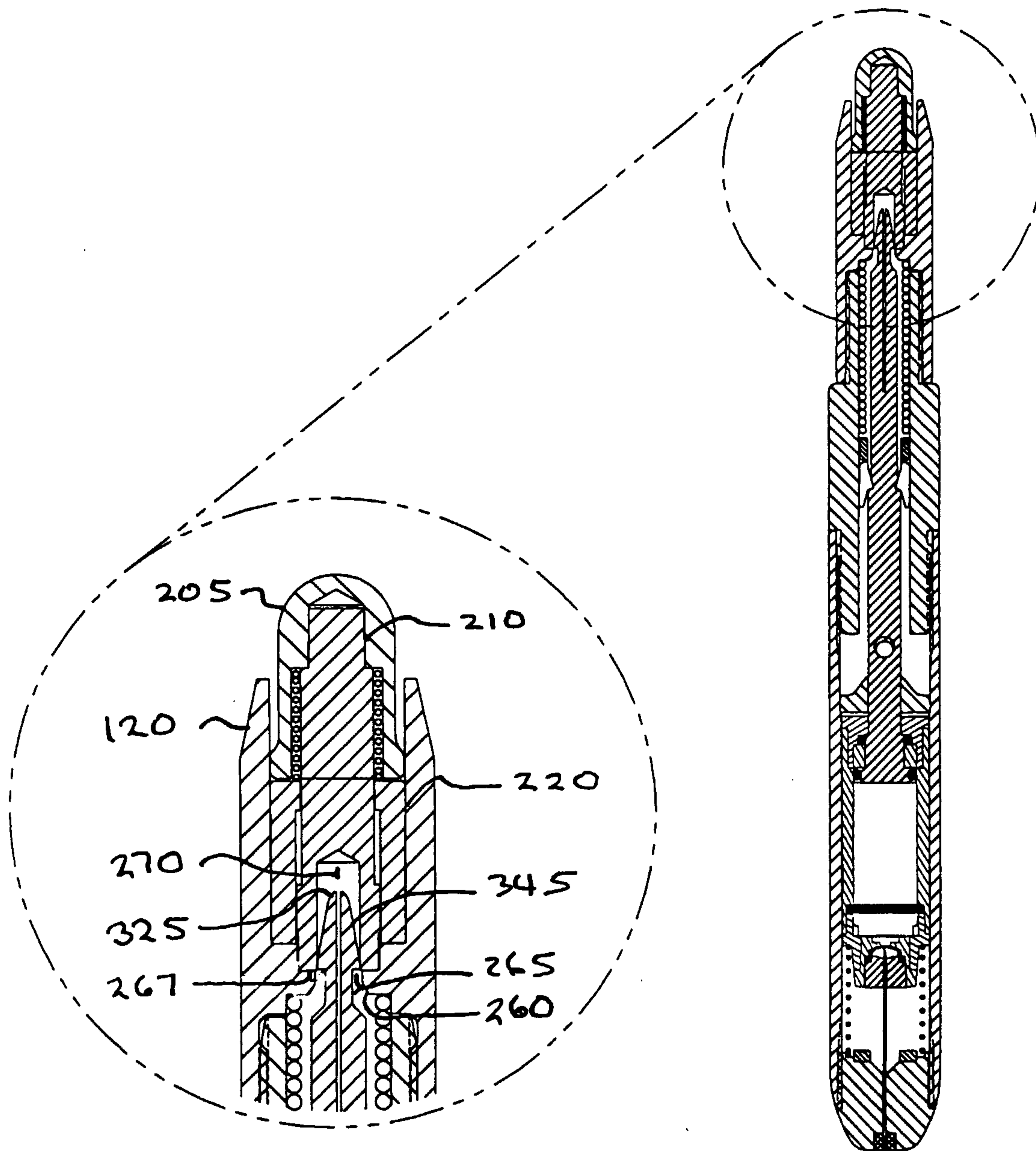

FIG. 4

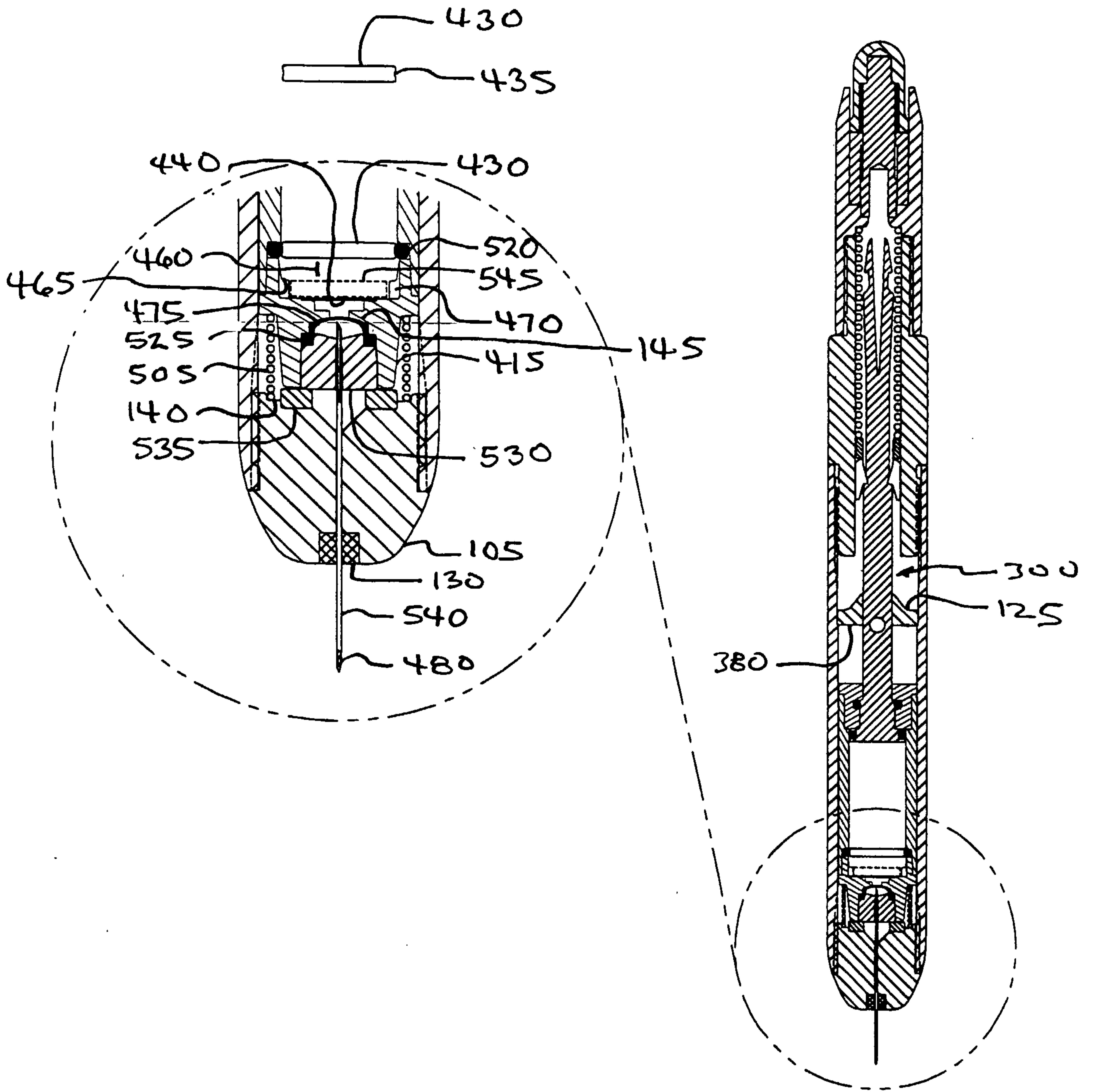

FIG. 5

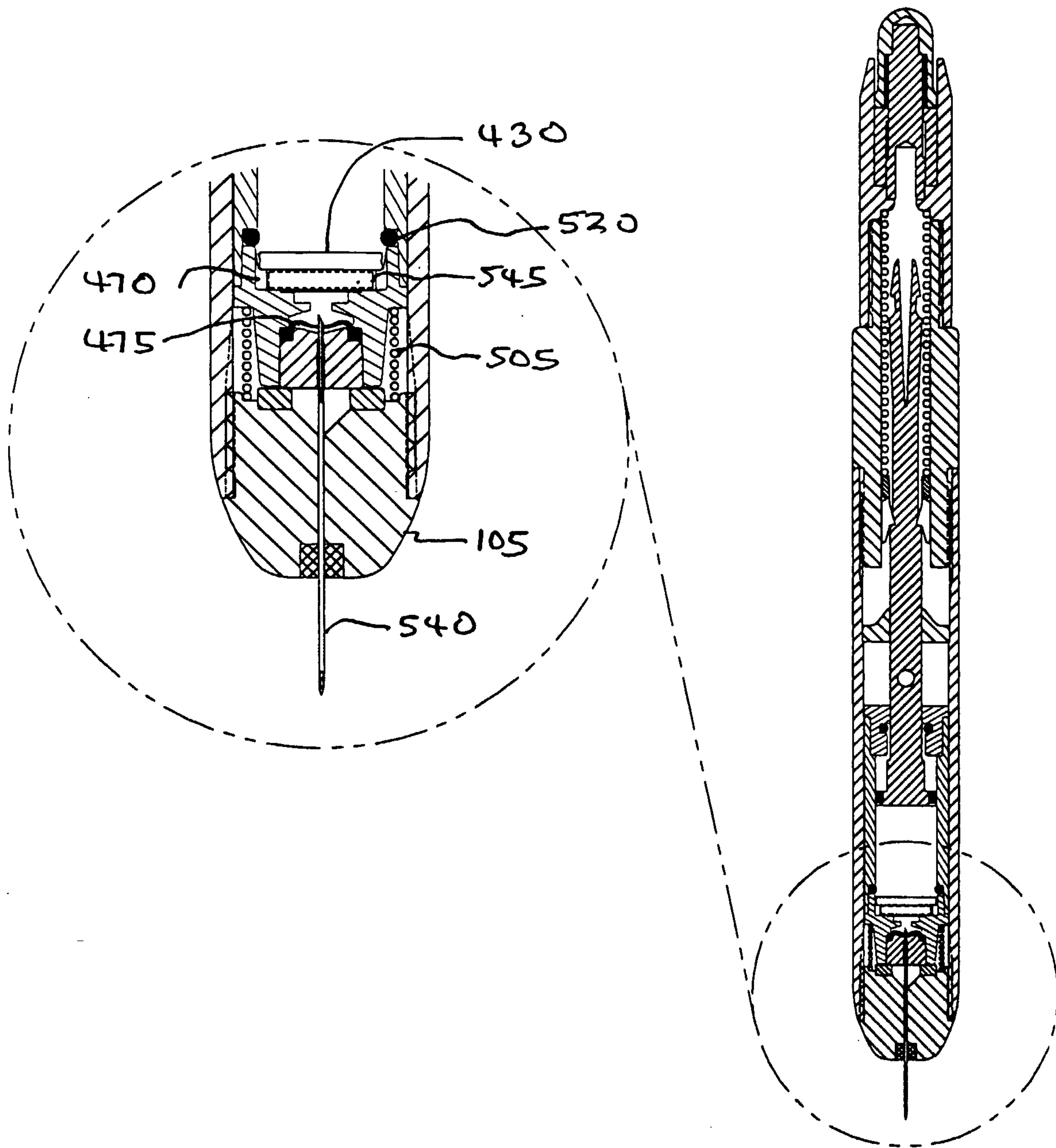

FIG. 6

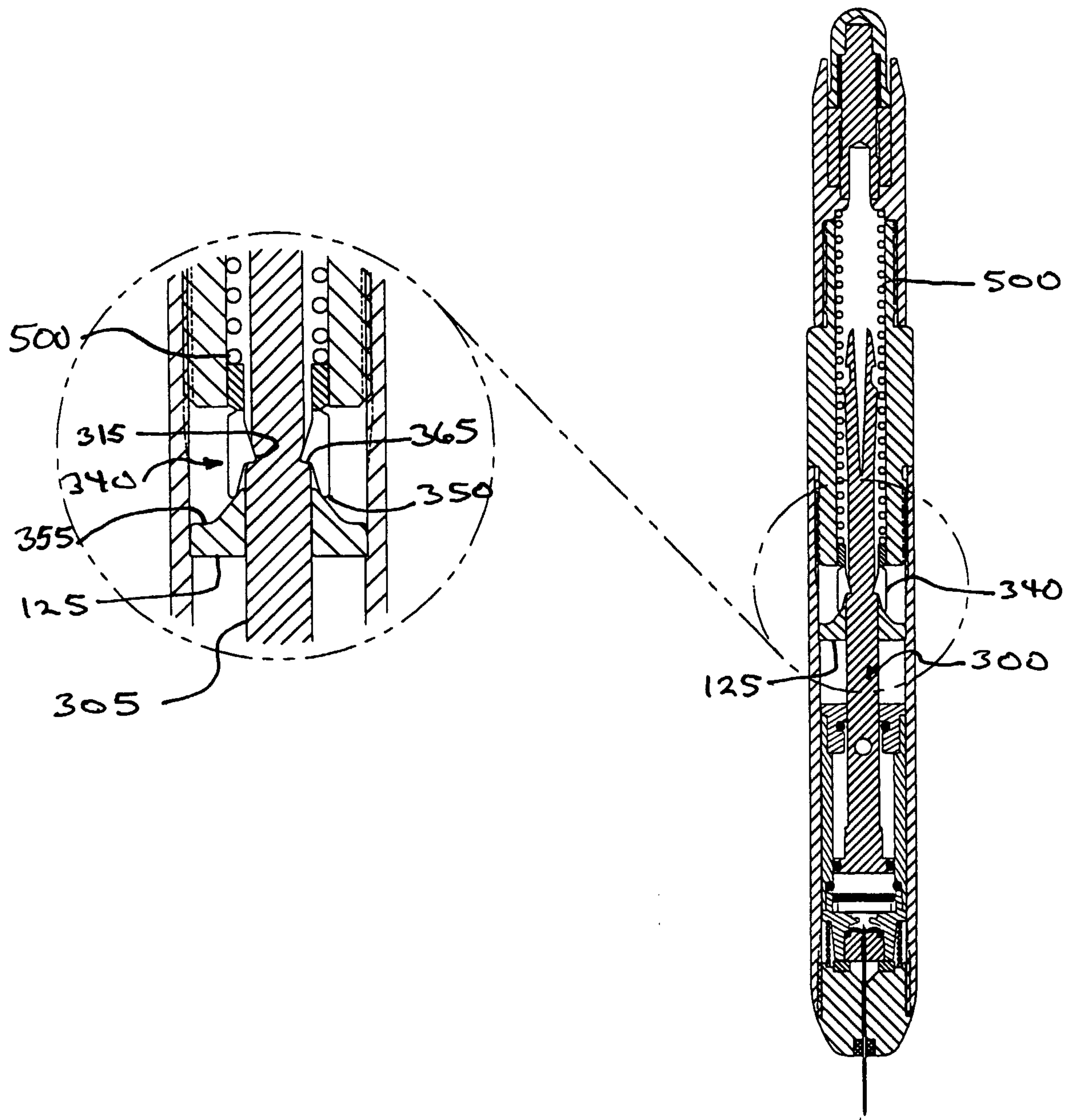

FIG. 7

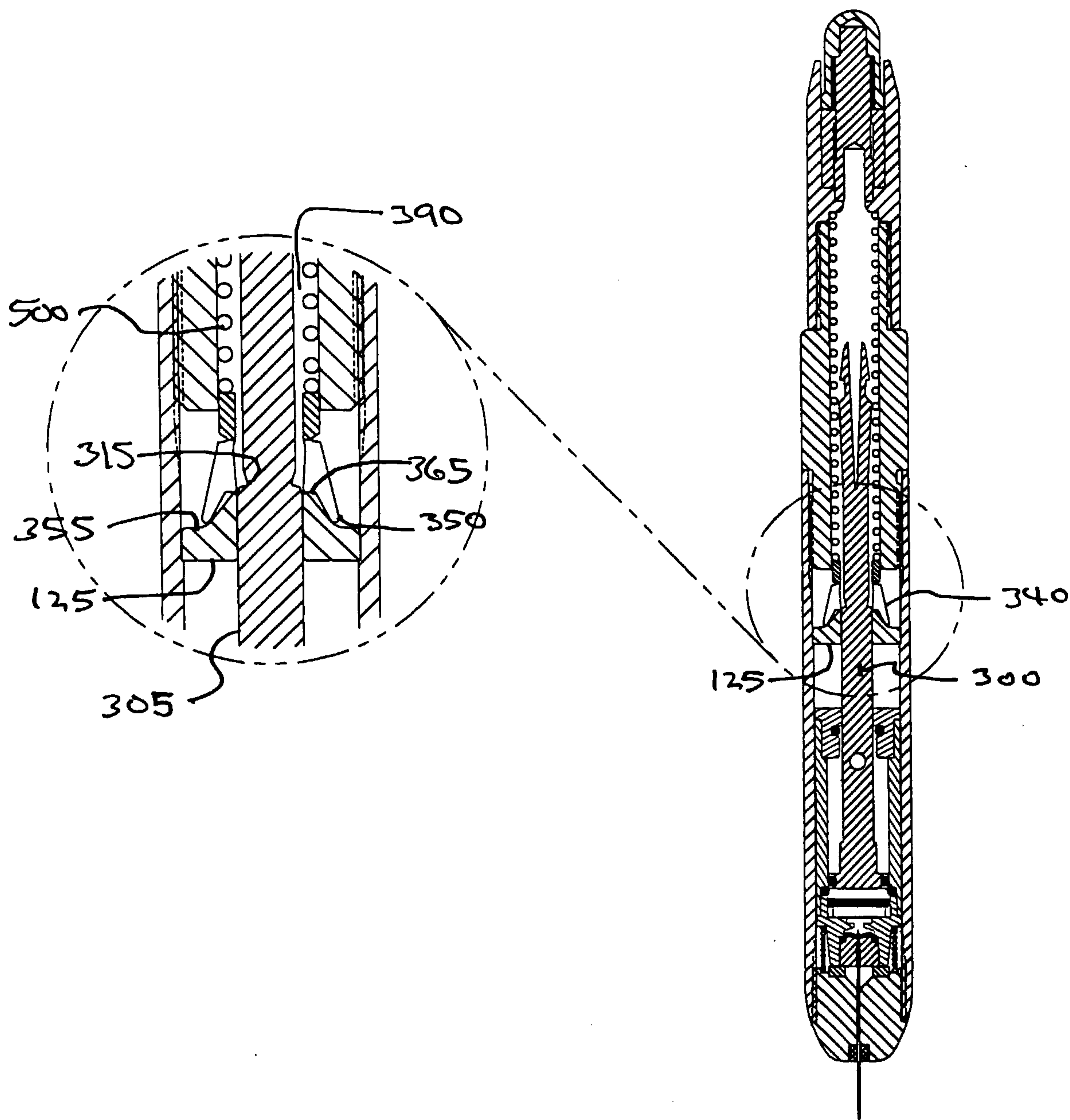

FIG. 8

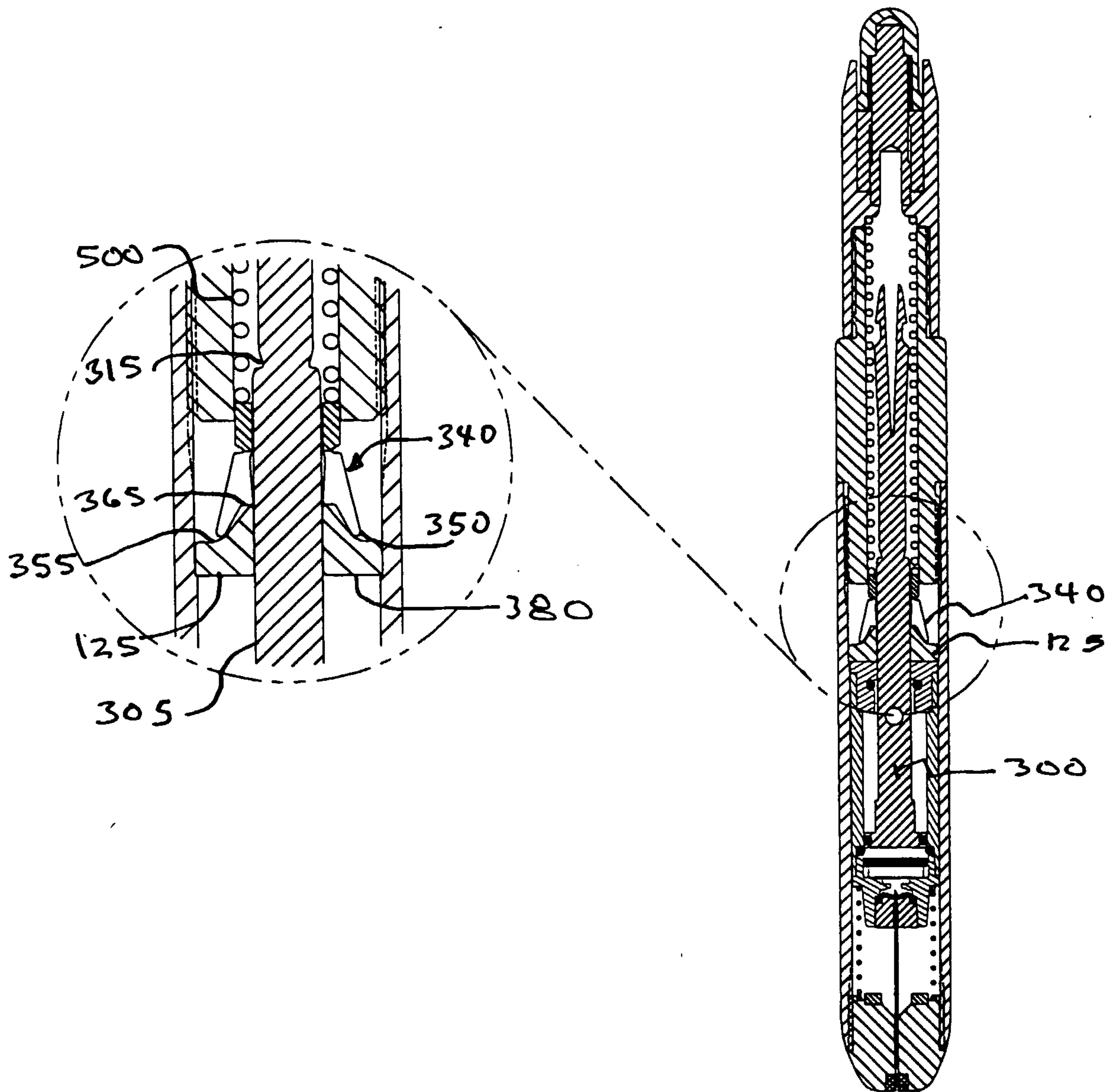

FIG. 9

