

J. POHORALEK.
 SHEET HOLDER.
 APPLICATION FILED NOV. 26, 1910.

999,862.

Patented Aug. 8, 1911.

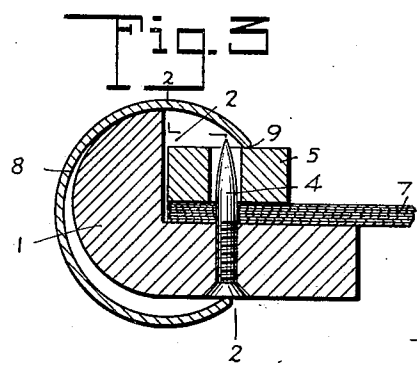
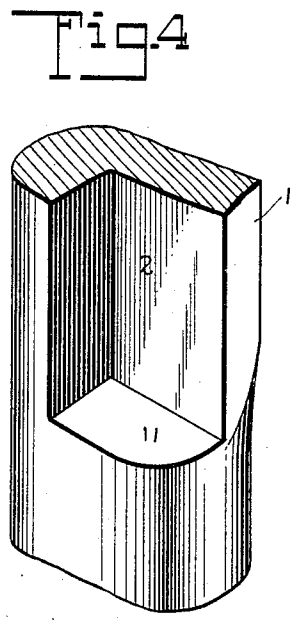
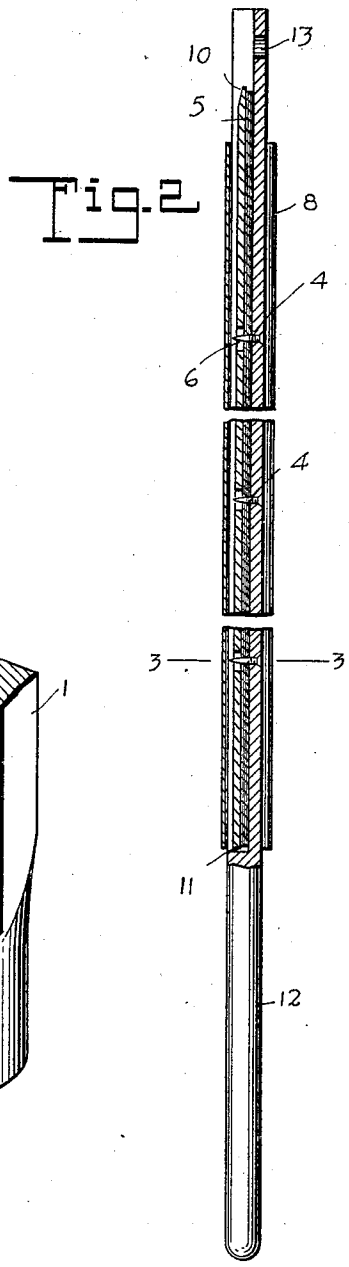
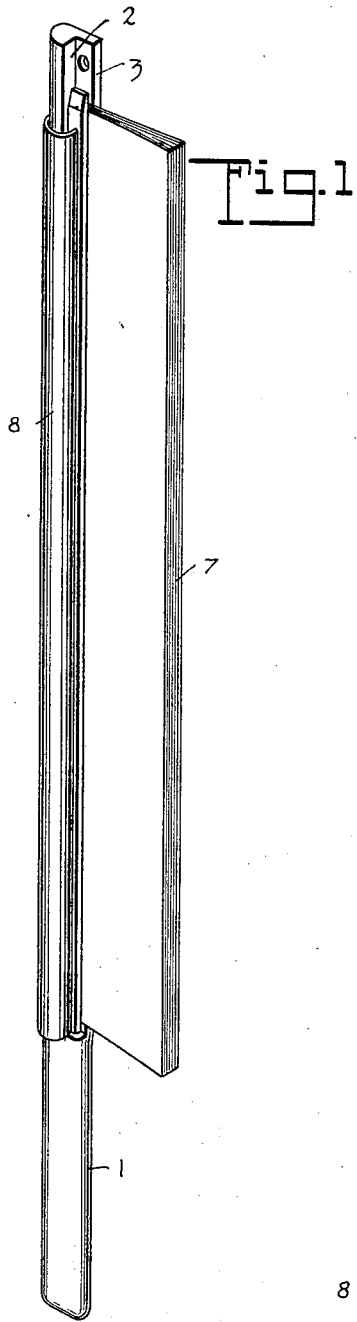

WITNESSES
J. A. Propley
H. Whitney

INVENTOR
 Johannes Pohoralek
 BY *Mund...*
 ATTORNEYS

UNITED STATES PATENT OFFICE.

JOHANNES POHORALEK, OF NEW YORK, N. Y.

SHEET-HOLDER.

999,862.

Specification of Letters Patent.

Patented Aug. 8, 1911.

Application filed November 26, 1910. Serial No. 594,281.

To all whom it may concern:

Be it known that I, JOHANNES POHORALEK, a subject of the Emperor of Austria-Hungary, and a resident of the city of New York, borough of Manhattan, in the county and State of New York, have invented a new and Improved Sheet-Holder, of which the following is a full, clear, and exact description.

This invention relates to a new and improved holder adapted to support and secure a plurality of sheets in an assembled and readily accessible position, these sheets being of any suitable character, such as newspapers, blue-prints or the like.

An object of this invention is to provide a device which will be simple in construction, inexpensive to manufacture, readily accessible, strong and durable.

A further object of this invention is to provide a plurality of clamping faces, between which any desired sheets may be secured and held in position by a lock.

These and further objects, together with the construction and combination of parts, will be more fully described hereinafter and particularly set forth in the claims.

Reference is to be had to the accompanying drawings forming a part of this specification, in which similar characters of reference indicate corresponding parts in all the views, and in which—

Figure 1 is a perspective view; Fig. 2 is a vertical section on the line 2—2 of Fig. 3; Fig. 3 is a horizontal transverse section on the line 3—3 of Fig. 2; and Fig. 4 is an enlarged fragmentary perspective view.

Referring more particularly to the separate parts of the invention as embodied in the form illustrated in the drawings, 1 indicates the body portion, which may be of any suitable form and material, but preferably consists of an elongated member having an angular rabbet or channel 2 extending lengthwise thereof for the greater portion of its length. This channel forms on the member 1 a flange 3, to which are secured a plurality of fasteners 4 of any suitable character, such as screws sharpened to points, which project into the channel 2. The newspapers or blue-prints or other sheets to be carried by the holder are forced onto the pointed fasteners 4, so that the latter project through the same. For the purpose of securing the sheets on the body portion 1, there is provided a strip 5 of any

suitable material, and of somewhat less dimensions than the channel 2, so that it can fit readily therein without projecting. This strip is provided with a plurality of openings 6 adapted to extend over the pointed fasteners 4, so as to prevent the movement of the strip relative to the body portion.

In order to hold the strip and the body portion together with their clamping faces securely gripping the sheets 7 interposed between them, there is provided a lock 8, which may be of any suitable character, but is shown in the form of a tube having a slot 9 extending lengthwise thereof, whereby the tube may be inserted endwise over the body portion and the strip 5, with the edges of the slot engaging on the back sides of the body portion and the strip. This tubular lock 8 is made of springy material, so that it will yield slightly, and at the same time exert a contracting tension, which will tend to force the body portion 1 and the strip 5 more closely together. One end of the strip 5 is preferably beveled, as at 10, so that this locking tube 8 may be more readily inserted over the holder. The channel 2 ends at 11, so as to provide a stop for the tubular lock 8, preventing its further movement. The remainder of the body portion projecting beyond the stop 11 is shaped in the form of a handle 12, whereby the holder may be readily handled.

Any suitable means for supporting the hanger on a hook or the like may be provided, as for example the opening 13, shown at the upper end of the body portion of the flange 3.

The utility of the device will be readily understood when taken in connection with the above description. When it is desired to secure sheets of any suitable character, such as newspapers, blue-prints or the like, in a smooth, extended position, the locking tube 8 is slipped off the end of the holder, and the sheets secured to the body portion by forcing them onto the pointed fasteners 4. The strip 5 is then placed over the fasteners, so that its clamping face will engage the sheets, and so that its openings 6 will extend over the pointed fasteners 4. When the parts are thus in this position, the tubular lock 8 is slid onto the holder endwise. The bevel 10 permits the tube to slide on easily, and yet, by the increased thickness, causes it to spread slightly where it is normally under a contracting tension, tend-

ing to secure the body portion and the strip 5 more closely together, and thus secure the sheets 7 more positively in place. When the sheets are not being used, the device can be 5 hung up by means of the opening 13. The sheets 7 may be left extended, or they may be rolled up on to the holder, so as to protect them from damage.

It will thus be seen that there is provided 10 a simple and efficient device, which will securely hold any number of sheets desired, in a manner such that they will always be readily accessible and held in a smooth, clean condition.

15 While I have shown one embodiment of my invention, I do not wish to be limited to the specific details thereof, but desire to be protected in various changes, alterations and modifications which may come within the 20 scope of the appended claims.

Having thus described my invention, I claim as new and desire to secure by Letters Patent:—

1. The combination with a body portion 25 having a channel therein, of a strip adapted to be inserted in said channel, and a tubular lock having a slot extending lengthwise thereof, adapted to be slid endwise on said body portion and said strip, so that the edges 30 of said slot engage said body portion and said strip respectively.

2. The combination with a body portion 35 having a channel therein forming a flange on said body portion, of a plurality of pointed fasteners secured to said flange and projecting in said channel, a strip having a plurality of openings therein adapted to engage said pointed fasteners, and a tubular 40 lock having a slot therein, slidingly mounted so as to move endwise on said body portion and said strip and so as to have the

edges of said slot engage said body portion and said strip.

3. The combination with a body portion 45 having a channel therein forming a flange on said body portion, of a plurality of pointed fasteners secured to said flange and projecting in said channel, a strip having a plurality of openings therein adapted to engage 50 said pointed fasteners, and a tubular lock having a slot therein, adapted to be placed endwise on said body portion and said strip, and so as to have the edges of said slot engage said body portion and said strip, said 55 channel extending a portion of the length of said body portion and terminating in a stop adapted to limit the motion of said tubular lock.

4. The combination with a body portion 60 having a channel therein forming a flange on said body portion, of a plurality of pointed fasteners secured to said flange and projecting in said channel, a strip having a plurality of openings therein adapted to engage 65 said pointed fasteners, and a tubular lock having a slot therein, adapted to be placed endwise on said body portion and said strip, and so as to have the edges of said lock engage said body portion and said strip, said 70 channel extending a portion of the length of said body portion and terminating in a stop adapted to limit the motion of said tubular lock, said body portion having an opening therein adapted to engage a hook to support 75 said body portion.

In testimony whereof I have signed my name to this specification in the presence of two subscribing witnesses.

JOHANNES POHORALEK.

Witnesses:

HORATIO WHITING,
PHILIP D. ROLLHAUS.