

(No Model.)

2 Sheets—Sheet 1.

H. B. BEAIRSTO & H. S. BECKWITH.
GRINDING MACHINE.

No. 525,939.

Patented Sept. 11, 1894.

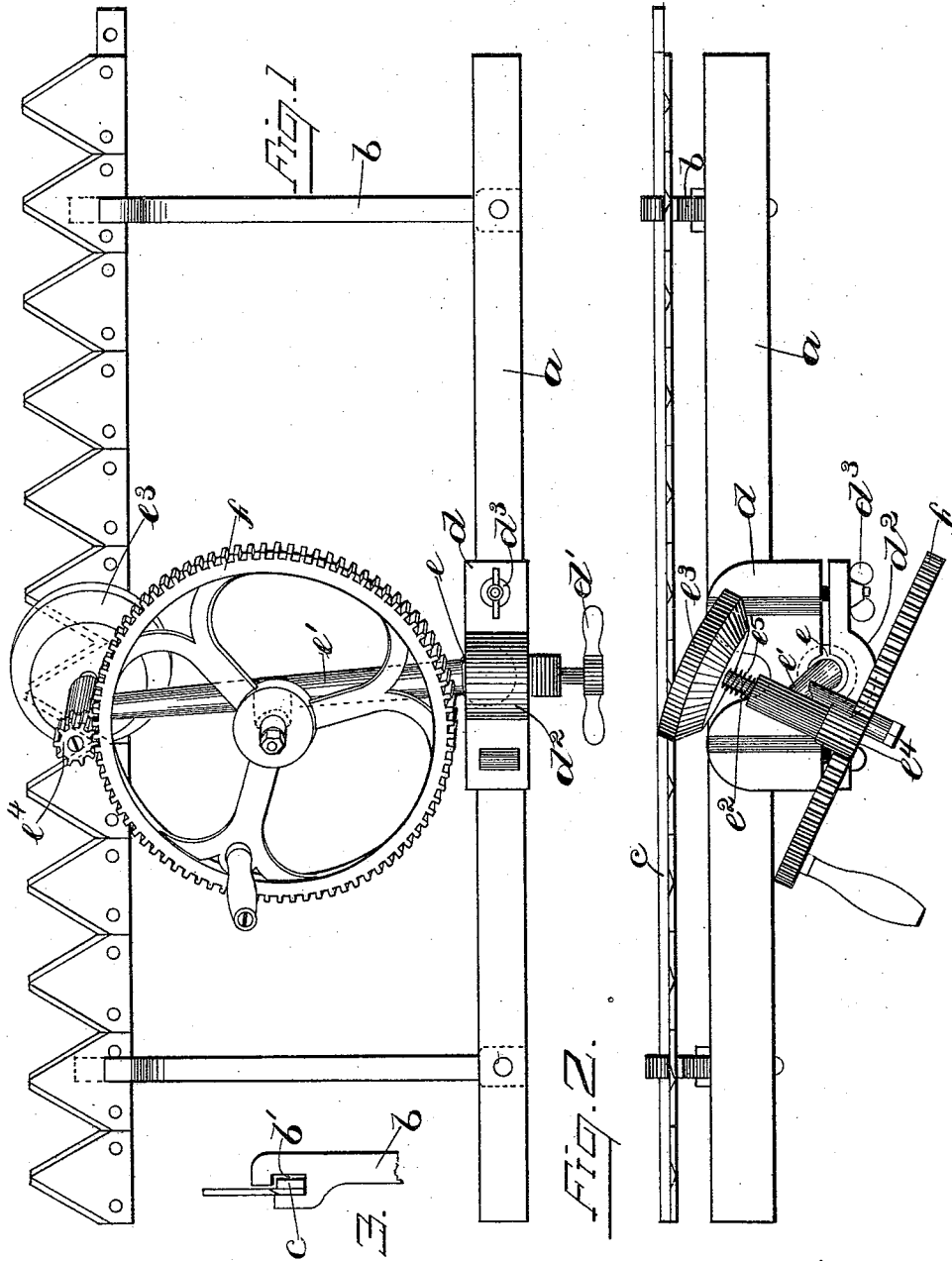

WITNESSES
Charles B. Crocker.
Florence Davis

FIG. 3.

INVENTORS
Henry B. Beairsto.
Horatio S. Beckwith.
by B. J. Hayes atty.

FIG. 2.

(No Model.)

2 Sheets—Sheet 2.

H. B. BEAIRSTO & H. S. BECKWITH.
GRINDING MACHINE.

No. 525,939.

Patented Sept. 11, 1894.

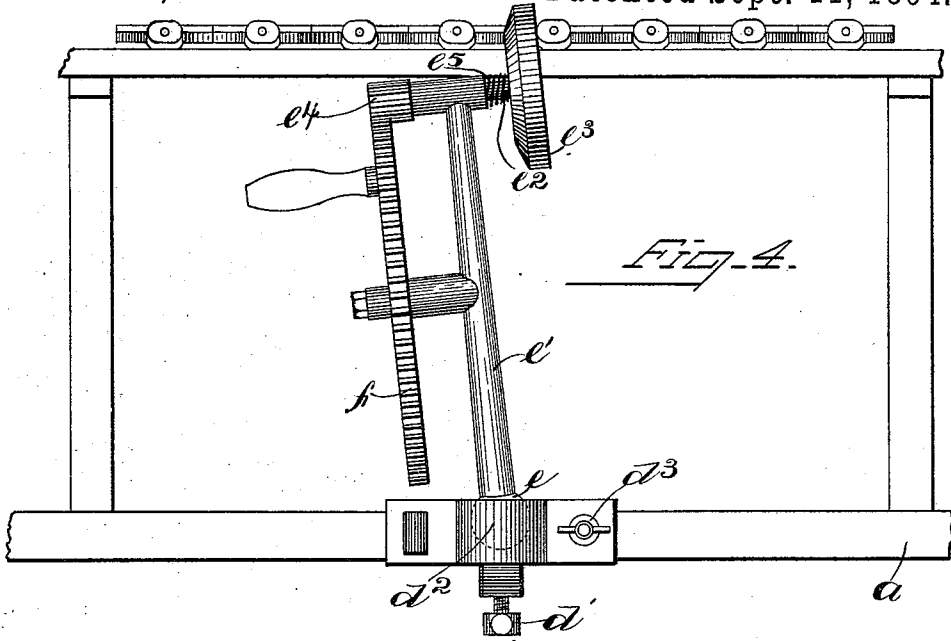

Fig. 4.

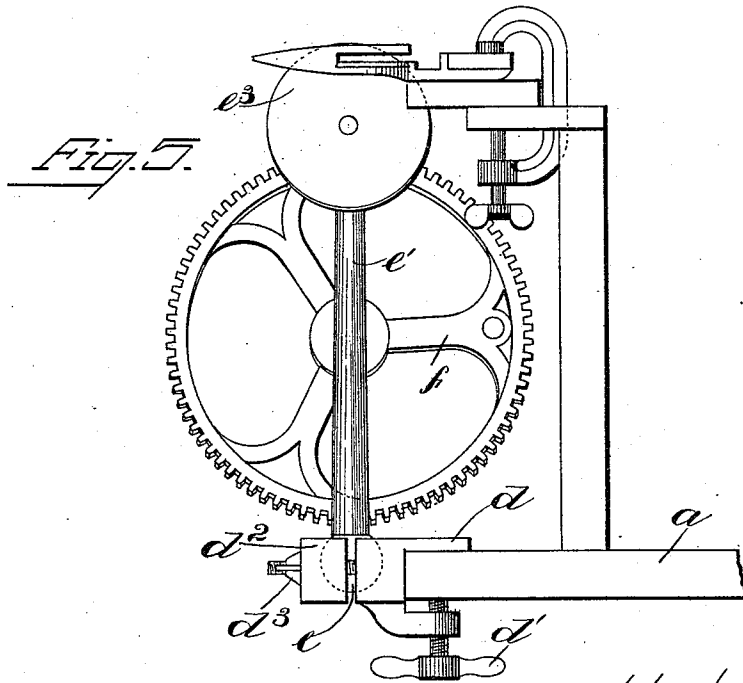

Fig. 5.

WITNESSES.
Charles B. Crocker.
Florence Davis

INVENTORS
Henry B. Beairsto,
Horatia S. Beckwith,
by B. J. Hayes atty.

UNITED STATES PATENT OFFICE.

HENRY B. BEAIRSTO AND HORATIO S. BECKWITH, OF FORT FAIRFIELD,
MAINE.

GRINDING-MACHINE.

SPECIFICATION forming part of Letters Patent No. 525,939, dated September 11, 1894.

Application filed April 7, 1894. Serial No. 506,678. (No model.)

To all whom it may concern:

Be it known that we, HENRY B. BEAIRSTO and HORATIO S. BECKWITH, of Fort Fairfield, county of Aroostook, State of Maine, have invented an Improvement in Grinding-Machines, of which the following description, in connection with the accompanying drawings, is a specification, like letters on the drawings representing like parts.

10 This invention has for its object to improve the construction of grinding machines especially designed for grinding scythes or cutting blades and also guards of mowing machines, the principal advantage gained being the facility with which the work may be done, particularly when grinding the guards.

15 The invention consists in a grinding wheel secured to an endwise yielding shaft, supported at the upper end of a stand, the lower end of which is connected by a universal joint to a clamp-like base plate which is adapted to be secured to different points of a longitudinal frame bar, and means for securing said stand in any different position at which
25 it may be set, in order that the grinding wheel may be securely held with its acting face turned in different ways, to act upon the cutting blades and guards, and means for rotating said grinding wheel; also in a holder for the scythes or cutting blades which is adapted to receive and permit endwise and also a tilting movement of the blade.

30 Figure 1, shows in front elevation a grinding machine embodying this invention as adapted for use in grinding the scythe or cutting blade of a mowing machine; Fig. 2, a plan view of the machine shown in Fig. 1; Fig. 3, a detail of the holder for the cutting blade; Fig. 4, a front elevation of the grinding machine as adapted for use in grinding the guards of a mowing machine, and Fig. 5, a side view of the same.

35 The longitudinal frame bar *a* is made of suitable length, and provided at or near each end with a vertical support or arm *b*, having at its upper end a slotway *b'* of sufficient size to receive and permit free endwise and also tilting movement of the cutting blade *c*. The cutting blade *c* will be inserted in its holders
40 endwise. The base plate *d* provided with a clamping screw *d'* is adapted to be secured

to the frame bar *a*, at any desirable point. The outer edge of said base plate *d* has a hemispherical socket or recess, and a plate *d²* is loosely connected at one end to the outer edge of the base plate *d*, the inner face of which has also a hemispherical socket or recess, and a clamping screw *d³* is provided for said outer plate *d²*, by means of which it may be moved toward or from the outer edge of the base plate and securely held. The hemispherical sockets or recesses lie opposite each other, and receive the spherical end piece *e*, formed upon the lower end of an upright stand *e'*, the upper end of which is formed to afford a good and sufficient bearing for a shaft *e²*, which is provided at one end with a grinding wheel *e³*, and at the opposite end with a toothed pinion *e⁴*. A spiral spring *e⁵* encircles the shaft *e²*, bearing at one end against the grinding wheel, and at the opposite end against the bearing, thereby giving to said endwise moving shaft a yielding action. A toothed gear *f*, is secured to a stud supported by the stand *e'* at a point about mid-way its length, which engages a pinion *e⁴*, and said gear wheel is provided with a hand piece by which it may be turned.

By providing the lower end of the stand with a spherical end piece *e* as shown, and providing a bearing therefor it will be seen that a universal joint is obtained, enabling the grinding wheel to be turned in any different way desired, and by making the bearing of said universal joint as a split bearing, having a clamping screw, it will be seen that the joint may be tightened so as to securely hold the stand in any different position that it may be set.

By making the stand higher than the diameter of the gear wheel, it will be seen that the grinding mechanism may be turned on its universal joint, so that the grinding wheel may act upon the beveled edges of the cutting blades as shown in Fig. 1, and also upon the sides of the guards as shown in Figs. 4 and 5, which latter action it could not accomplish unless so made.

When grinding the guards as represented in Figs. 4 and 5, it is not the intention to use the cutting blade holder. By making the cutting blade holder substantially in the man-

ner shown it will be seen that the grinding machine may be set at any desired point on the frame bar, and the cutting blade then moved along endwise and also tilted by hand.

5 We claim—

1. In a grinding machine for mowing machine blades and guards, the combination of a grinding wheel, a spring pressed longitudinally movable shaft therefor, a stand at the
10 upper end of which said shaft has its bearing, means for rotating said shaft, a spherical end piece at the lower end of said stand, and a clamp-like base plate recessed to receive and
15 hold said spherical end piece, thereby forming a universal joint connecting the lower end of said stand with the base plate, substantially as described.

2. In a grinding machine the combination of a grinding wheel, a yielding endwise moving shaft therefor, a stand at the upper end

of which said shaft has its bearing, a pinion on said shaft, a gear wheel for rotating it the diameter of which is less than the height of the stand, a clamp-like base plate for said stand comprising two parts each having a
25 hemispherical socket to receive the spherical end piece at the lower end of the stand, and a clamping screw for drawing said parts together thereby securely holding the stand in
30 any different position that it may be set, substantially as described.

In testimony whereof we have signed our names to this specification in the presence of two subscribing witnesses.

HENRY B. BEAIRSTO.
HORATIO S. BECKWITH.

Witnesses:

STEADMAN D. BECKWITH,
CHARLES W. TURNBULL.