



US00D474145S

(12) **United States Design Patent** (10) **Patent No.:** **US D474,145 S**  
**Dawson et al.** (45) **Date of Patent:** **\*\* May 6, 2003**

(54) **HALF TOP WITH A PIVOTING SUNROOF**

FOREIGN PATENT DOCUMENTS

(75) Inventors: **Paul C. Dawson**, Lakewood, CO (US);  
**Richard C. Essig**, Berthoud, CO (US);  
**Dorothy N. Kohn**, Longmont, CO (US)

JP 6106986 4/1994

OTHER PUBLICATIONS

(73) Assignee: **Bestop, Inc.**, Broomfield, CO (US)

Sales Brochure of Bestop, Inc., 1999.  
Special Edition 2001 of "Essentials" (Quadratec), 2001, pp  
17-19, 26, 28, and 31.  
Installation Instruction Sheets for the Cab Top of Rock  
Crusher, 2001.

(\*\*) Term: **14 Years**

\* cited by examiner

(21) Appl. No.: **29/152,789**

*Primary Examiner*—Stacia Cadmus

(22) Filed: **Oct. 26, 2001**

(74) *Attorney, Agent, or Firm*—W. Scott Carson

(51) **LOC (7) Cl.** ..... **12-16**

(52) **U.S. Cl.** ..... **D12/401**

(58) **Field of Search** ..... D12/401, 404,  
D12/403, 90-92, 86; 296/218, 224, 210-213,  
183-186, 220-222, 216, 10, 136, 156, 99.1,  
107.11-107.12, 114-116; 150/154, 166;  
280/770, 847-848, DIG. 5-6; 160/DIG. 3,  
370.21-370.23

(57) **CLAIM**

The ornamental design for a half top with a pivoting sunroof,  
as shown and described.

**DESCRIPTION**

FIG. 1 is a perspective view of a half top with a pivoting  
sunroof showing our new design. The broken lines showing  
the vehicle are for illustrative purposes only and form no  
part of our design.

(56) **References Cited**

**U.S. PATENT DOCUMENTS**

D198,780 S	*	8/1964	Van De Pavert	.....	D12/401
4,066,292 A		1/1978	Carli		
D259,340 S	*	5/1981	Stengel	.....	D12/401
D268,408 S	*	3/1983	Ruggles	.....	D12/401
D291,552 S	*	8/1987	Muscat	.....	D12/401
D324,196 S	*	2/1992	Muth	.....	D12/401
5,299,850 A		4/1994	Kaneko et al.		
D384,324 S	*	9/1997	Barker	.....	D12/401
5,673,959 A		10/1997	Padlo		
D408,781 S	*	4/1999	Gordon	.....	D12/401
5,947,546 A		9/1999	Hilliard et al.		
D432,074 S	*	10/2000	Harris	.....	D12/401
D435,509 S	*	12/2000	Hickman	.....	D12/401
D442,911 S	*	5/2001	Essig et al.	.....	D12/401

FIG. 2 is a left side elevational view thereof, the right side  
elevational view being a mirror image thereof. The broken  
lines showing the vehicle are for illustrative purposes only  
and form no part of our design.

FIG. 3 is a front elevational view thereof taken along line  
3-3 of FIG. 2.

FIG. 4 is a rear elevational view thereof taken along line  
4-4 of FIG. 2.

FIG. 5 is a top plan view thereof taken along line 5-5 of  
FIG. 3; and,

FIG. 6 is a bottom plan view thereof taken along line 6-6  
of FIG. 3.

**1 Claim, 4 Drawing Sheets**

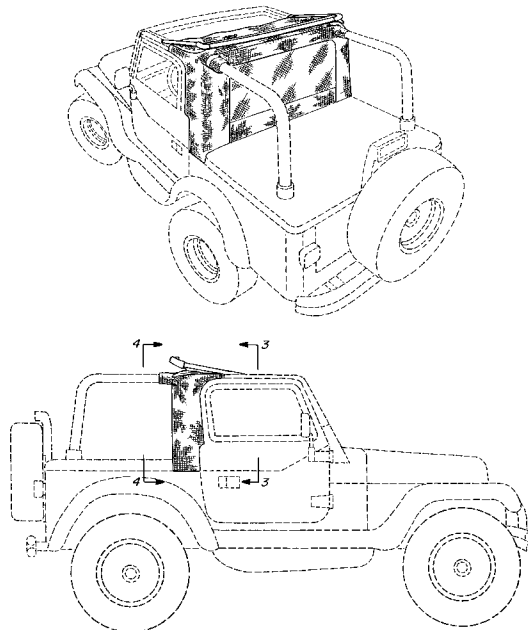

**Fig. 1**

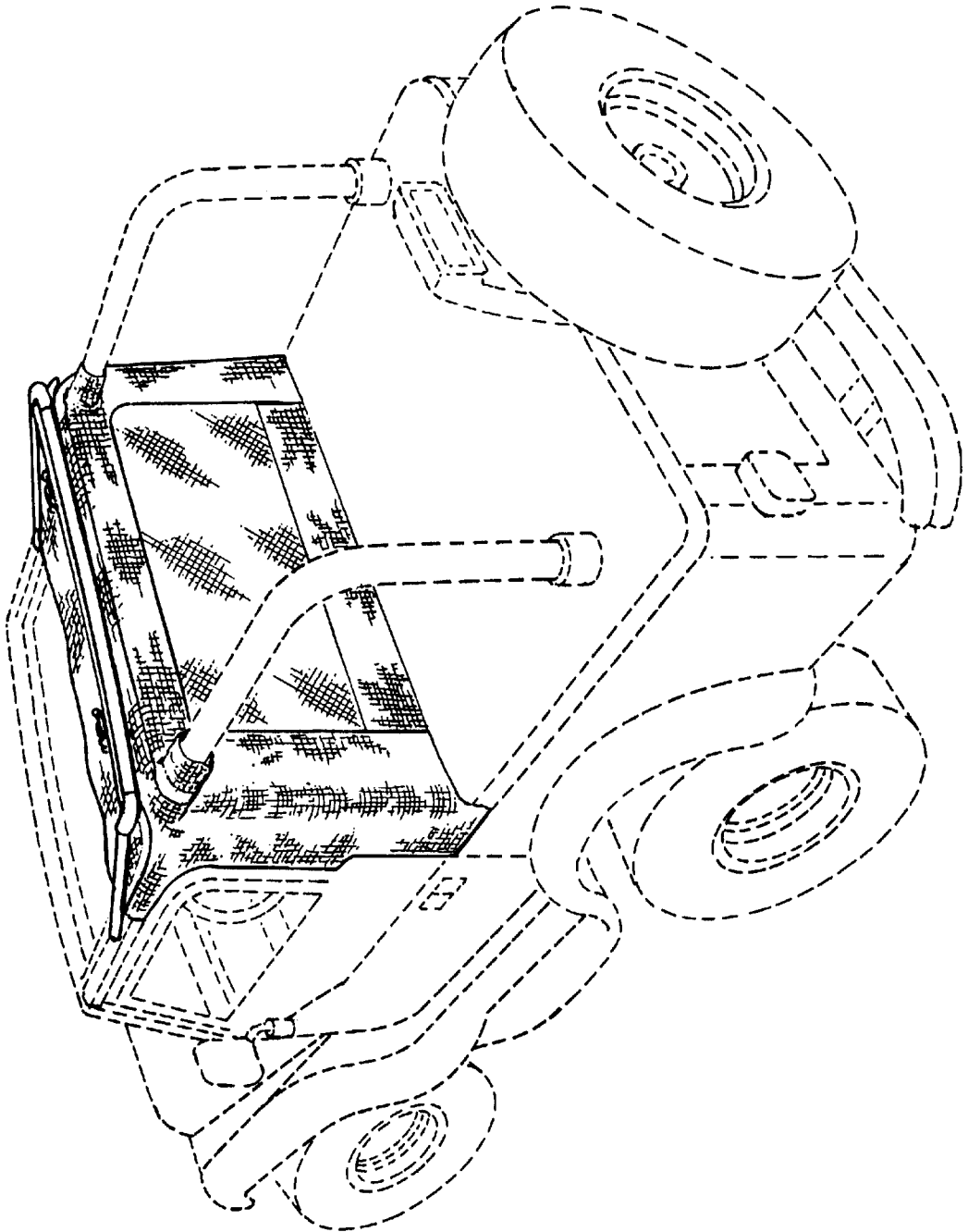

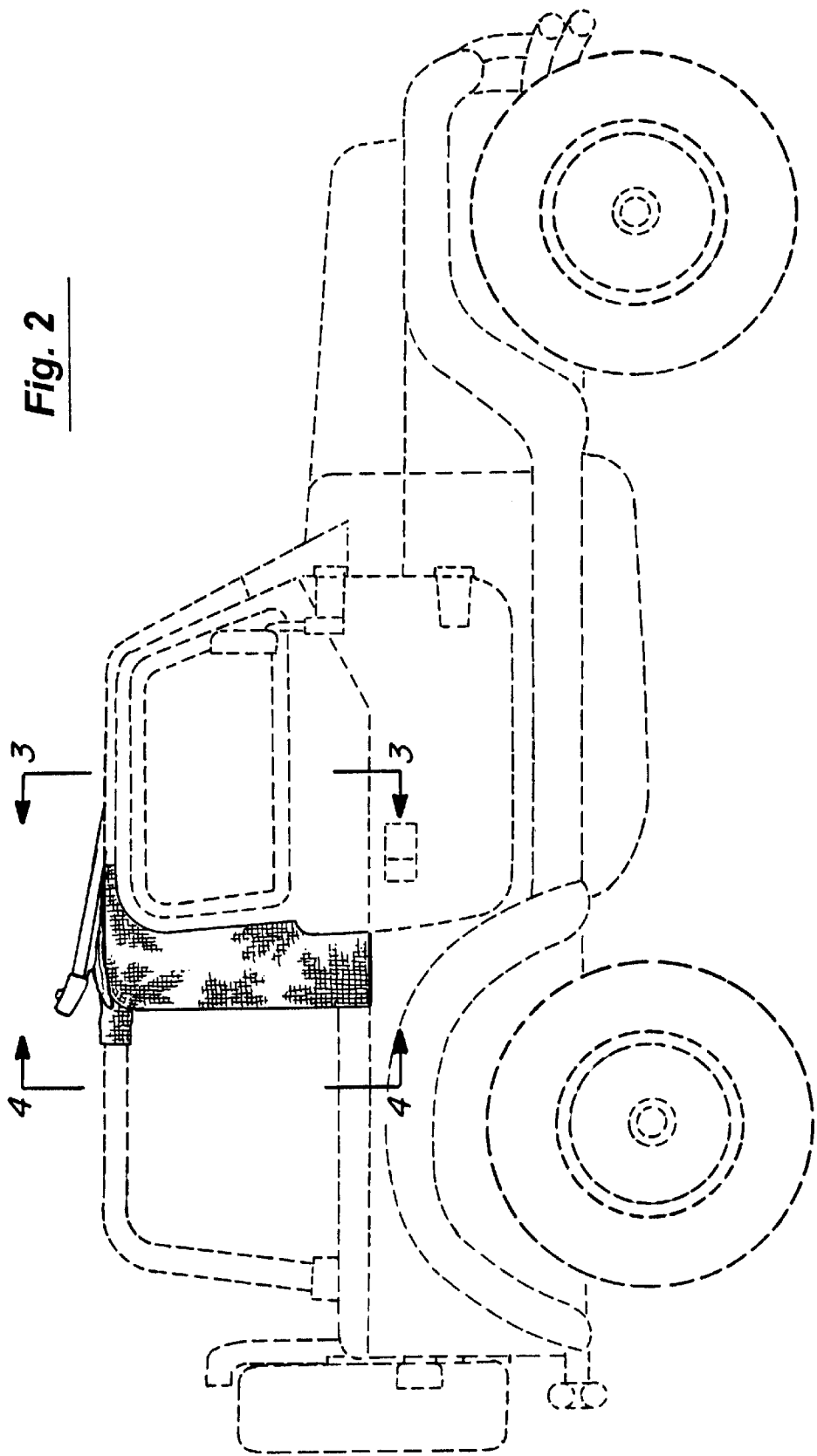

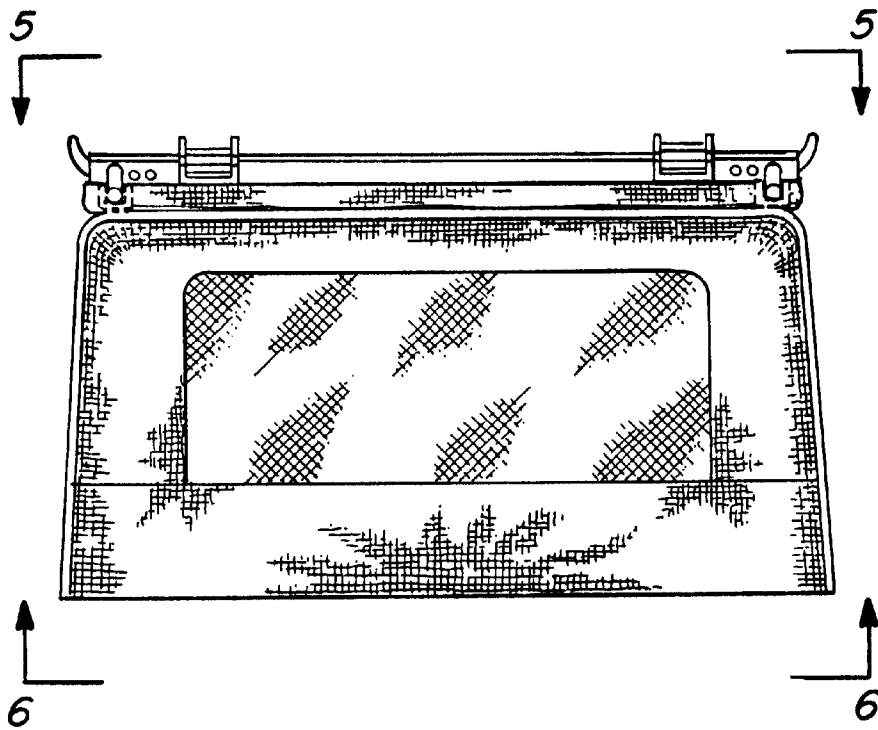

Fig. 3

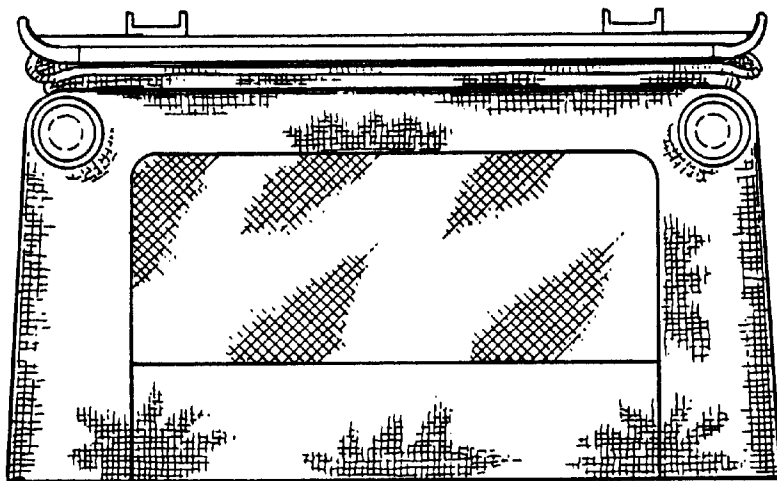

Fig. 4

Fig. 5

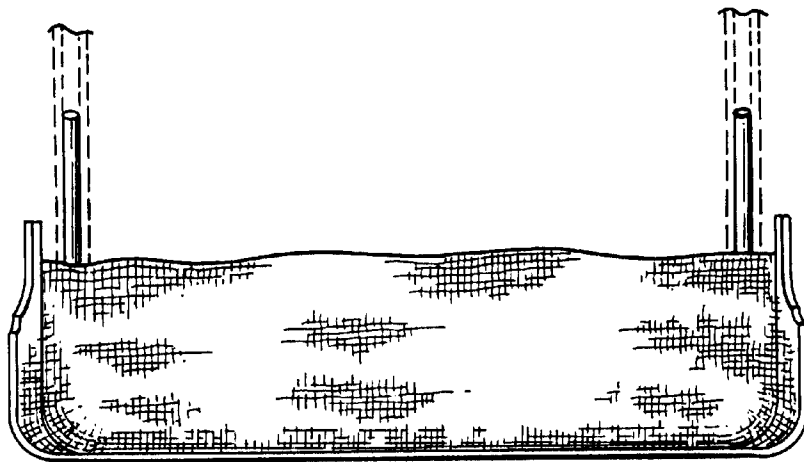
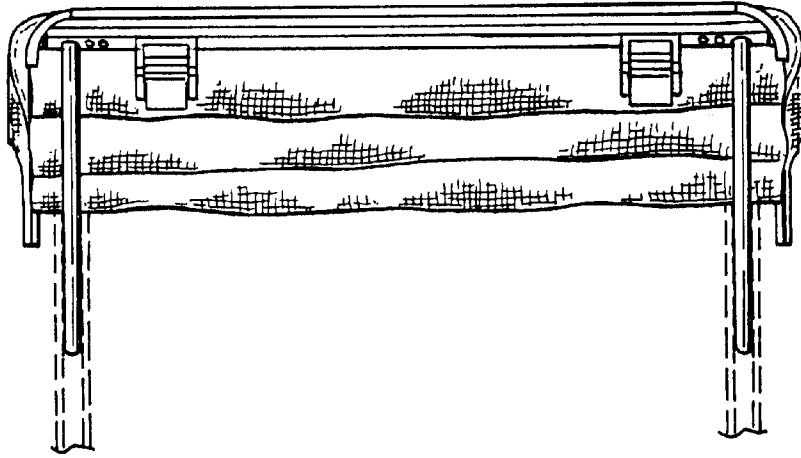

Fig. 6