



(72) NEWMAN, Robert L., US

(71) CTS CORPORATION, US

(51) Int.Cl.<sup>6</sup> G01N 27/16

(30) 1997/06/11 (08/872,817) US

(54) **DETECTEUR DE GAZ AVEC ELEMENTS ACTIFS A  
EXPOSITION MULTIPLE**

(54) **A GAS SENSOR WITH MULTIPLE EXPOSED ACTIVE  
ELEMENTS**

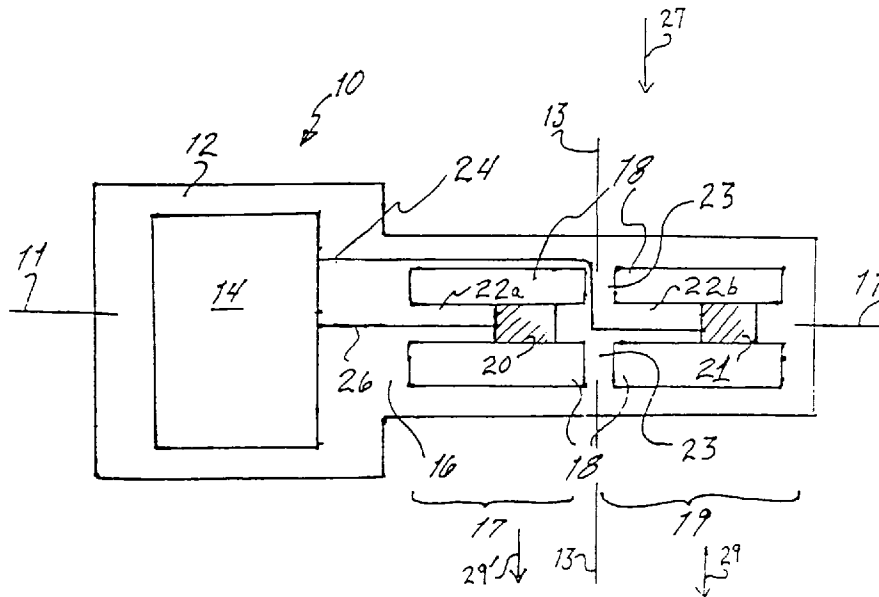

(57) Détecteur de gaz combustible ayant des éléments détecteurs catalytiques à résistance enrobée et utilisant un pont de Wheatstone. Il y a un noeud d'alimentation qui relie électriquement une extrémité d'un premier et d'un deuxième pont du pont de Wheatstone. Un noeud de mise à la terre raccorde électriquement le premier et le deuxième pont par l'autre extrémité. Il y a un premier et un deuxième noeud de mesure situés respectivement sur le premier et le deuxième pont. Il y a un premier élément détecteur catalytique, situé sur le premier pont entre le noeud d'alimentation et le premier noeud de mesure. Il y a un deuxième élément détecteur catalytique, situé sur

(57) A combustible gas detector or sensor having catalytic coated resistance sensing elements that uses a wheatstone bridge. Wherein there is a power supply node electrically coupling one end of a first and second bridge of the wheatstone bridge. There is a ground node electrically coupling the first and second bridge at another end. There is a first and second metered node located on the first and second bridge respectively. There is a first catalytic sensor element, located on the first bridge between the power node and first metered node. There is a second catalytic sensor element, located on the second bridge between the ground node and second



(21) (A1) **2,238,902**  
(22) 1998/05/28  
(43) 1998/12/11

le deuxième pont entre le noeud de mise à la terre et le deuxième noeud de mesure. Il y a un premier élément détecteur de référence, situé sur le premier pont et en série avec le premier élément détecteur catalytique, et raccordé entre le premier noeud de mesure et le noeud de mise à la terre. Finalement, il y a un deuxième élément détecteur de référence, situé sur le deuxième pont et en série avec le deuxième élément détecteur catalytique, et raccordé entre le deuxième noeud de mesure et le noeud d'alimentation.

metered node. There is a first reference sensor element, located on the first bridge and in series with the first catalytic sensor element, and coupled between the first metered node and the ground node. Finally, there is a second reference sensor element, located on the second bridge and in series with the second catalytic sensor element, and coupled between the second metered node and the power node.

CTS-1508

**ABSTRACT****A GAS SENSOR WITH MULTIPLE EXPOSED ACTIVE ELEMENTS**

5

A combustible gas detector or sensor having catalytic coated resistance sensing elements that uses a wheatstone bridge. Wherein there is a power supply node electrically coupling one end of a first and second bridge of the wheatstone bridge. There is a ground node electrically coupling the first and second bridge at another end. There is a first and second metered node located on the first and second bridge respectively. There is a first catalytic sensor element, located on the first bridge between the power node and first metered node. There is a second catalytic sensor element, located on the second bridge between the ground node and second metered node. There is a first reference sensor element, located on the first bridge and in series with the first catalytic sensor element, and coupled between the first metered node and the ground node. Finally, there is a second reference sensor element, located on the second bridge and in series with the second catalytic sensor element, and coupled between the second metered node and the power node.

10

15

CTS-1508

**A GAS SENSOR WITH MULTIPLE EXPOSED ACTIVE ELEMENTS****BACKGROUND OF THE INVENTION****CO-PENDING PATENT APPLICATIONS**

This application is related to the following:

1) co-pending U.S. application serial number 08/ , entitled , A GAS SENSOR WITH ORIENTATION INSENSITIVITY, attorney docket no. CTS-1509, filed June 11, 1997,

2) co-pending U.S. application serial number 08/ , entitled A GAS SENSOR WITH MULTI-LEVEL INSENSITIVITY CIRCUITRY, attorney docket no. CTS-1518, filed June 11, 1997, and

3) copending U.S. application serial number 60/017,112, entitled, FUEL SYSTEM LOW CURRENT RHEOSTAT, attorney docket no. CTS-1491, filed May 9, 1996.

The aforementioned are assigned to the assignee named in the present application and are herein incorporated by reference in their entirety.

**1. FIELD OF THE INVENTION**

This invention relates to the field of combustible gas detectors or sensors having both reference sensor elements and catalitic sensor elements exposed to the combustible hot gas stream without the use of a separate heating circuit.

**2. DESCRIPTION OF THE RELATED ART**

Various devices are well known for combustible gas detectors used to detect the presence of combustible gases such as those found in car engines. Typical circuits are configured to include at least one sensing element that may be a wire having a catalytic coating. The sensing element was used as one of four legs of a wheatstone bridge circuit. The other three legs consisted of two resistors and a compensator element. The compensator element was identical to the sensing element except that it did not bear a catalytic coating.

A current or voltage was applied to the bridge circuit to heat the surface of the catalytic coating affixed to the sensing element. Since the resistance values of the other three legs of the bridge were known, the resistance in the sensing element could be determined as the current or voltage was passed through the bridge.

When the sensing element was exposed to a combustible gas, such as hydrocarbon, the catalytic coating would begin to burn, increasing the temperature of the sensing element. As the temperature of the sensing element increased, the resistance of the element increased. Accordingly, the current passing through the element decreased. By comparing the resistance level of the sensing element to the resistance level of the compensator element, the presence of a combustible gas could be detected. Since the

CTS-1508

amount of gas caused a nearly linear increase or decrease in the resistance of the sensing element, the quantity of the gas could be accurately determined by calibrating the change in resistance. This is the basic operational principle of a catalytic combustible gas sensor.

### 5        3.        Related Art

Examples of patents related to the present invention are as follows, and each patent is herein incorporated by reference for the supporting teachings:

10            U.S. patent no. 5,055,269, is a temperature limited catalytic gas detector apparatus.  
               U.S. patent no. 4,818,977, is a combustible gas detector having temperature stabilization capability.

              U.S. patent no. 4,476,096, is a circuit arrangement for an apparatus for measuring and indicating the concentration of combustible gases and vapors contained in air.

15            U.S. patent no. 4,332,772, is a portable gas detector.

              U.S. patent no. 4,313,907, is an apparatus for the detection of a combustible gas.

              U.S. patent no. 4,039,852, is an exhalation inspecting apparatus.

              U.S. patent no. 4,033,169, is a hydrocarbon concentration sensor for use in engine exhaust gas.

20            U.S. patent no. 4,020,480, is a catalytic detecting apparatus for detecting combustible gases and vapors.

              U.S. patent no. 3,961,248, is a gas detector using gas sensing elements exhibiting different response characteristics.

25            U.S. patent no. 3,519,391, is a method of and apparatus for measuring combustible constituents of gas samples.

              U.S. patent no. 3,237,181, is a gas detecting circuit.

              U.S. patent no. 3,221,320, is a gas alarm circuit.

30            The foregoing patents reflect the state of the art of which the applicant is aware and are tendered with the view toward discharging applicants' acknowledged duty of candor in disclosing information that may be pertinent in the examination of this application. It is respectfully stipulated, however, that none of these patents teach or render obvious, singly or when considered in combination, applicant's claimed invention.

### 35        4.        Related Problem

              Referring to **FIG. 1**, there is a previous undisclosed design from the present inventors that illustrates one problem to be overcome by the additionally now disclosed preferred embodiments. Specifically, there is a sensor **10** having a base **12** with signal conditioning circuitry **14** that receives signals via traces **24** and **26** from sensing element structures **17** and **19**, which are located on either side of longitudinal axis **11**. Uniquely, the sensing element structures **17** and **19** are made up of sensing elements **20** and **21** that are located on parallel bridges **22** and thermally isolated by voids **18**. In operation, one

CTS-1508

skilled in the art will realize that all of the electrical signals will be skewed if the heated air flow 27 first interacts with the catalyzed sensing element and then contacts the reference sensor. The air contacting the reference sensor will have been heated by the catalytic reaction, thus skewing any resulting signals. To avoid this problem, great care must be given to ensure that the air 27 does not contact the sensor elements in this fashion. In particular, the sensor would have to be placed so the air either hits both sensors simultaneously or hits the reference sensor first. In either case it is very difficult to make sure that the sensor is so arranged when placing it in an exhaust gas air stream. However, the present invention has overcome the need for careful placement of the sensor 10 in air stream 27 and thus eliminating the potential signal skewing problem.

This and other problems will be solved by the preferred embodiments of the invention. A review of the specification, drawings, and claims will more clearly teach a skilled artisan of other problems that are solved by the preferred embodiments.

## SUMMARY OF THE INVENTION

It is a feature of the invention to provide a combustible gas detector or sensors having both reference sensor elements and catalytic sensor elements exposed to the combustible hot gas stream without the use of a separate heating circuit.

A further feature of the invention is to provide a gas detector that uses a wheatstone bridge. Wherein, there is a power supply node electrically coupling one end of a first and second bridge of the wheatstone bridge. There is a ground node electrically coupling the first and second bridge at another end. There is a first and second metered node located on the first and second bridge respectively. There is a first catalytic sensor element, located on the first bridge between the power node and first metered node. There is a second catalytic sensor element, located on the second bridge between the ground node and second metered node. There is a first reference sensor element, located on the first bridge and in series with the first catalytic sensor element, and coupled between the first metered node and the ground node. Finally, there is a second reference sensor element, located on the second bridge and in series with the second catalytic sensor element, and coupled between the second metered node and the power node.

A further feature of the invention is that the gas detector further comprises a base having one end for being heated during operation of the gas detector, the wheatstone bridge located on the one end thereof.

A further feature of the invention is that during operation of the gas detector, a heated gas steam portion is created as the gas stream passes over the first and second catalyzed sensor element, the first and second catalyzed sensor elements and the first and second sensor elements are positioned on the base so that as the base rotates about the axis, the heated gas stream portion will not contact the first or second sensor element.

A further feature of the invention is that the base includes a catalyzed sensor section for mounting both the first and second catalyzed sensor elements on opposing sides thereof. Additionally, the base includes a sensor section for mounting both the first

CTS-1508

and second sensor elements on opposing sides thereof.

A further feature of the invention is that the catalyzed sensor section and the sensor section have a void on at least two sides thereof.

The invention resides not in any one of these features per se, but rather in the particular combination of all of them herein disclosed and claimed. Those skilled in the art will appreciate that the conception, upon which this disclosure is based, may readily be used as a basis for the designing of other structures, methods and systems for carrying out the several purposes of the present invention. Further, the abstract is neither intended to define the invention of the application, which is measured by the claims, neither is it intended to be limiting as to the scope of the invention in any way.

## BRIEF DESCRIPTION OF THE DRAWINGS

**Fig. 1** is one embodiment of an undisclosed gas sensor designed by the inventors that illustrates one problem overcome by the preferred embodiments.

**Fig. 2** is one embodiment of the invention.

**Fig. 3** illustrates a preferred wheatstone bridge circuit embodiment of the invention.

**Fig. 4** illustrates a housing for holding the sensor.

**Fig. 5** is a plan view showing a closeup of the sensor element region.

**Fig. 6** is a cross-section of **Fig. 5** taken through section a-a showing one embodiment for a multilayered structure.

**Fig. 7** is an enlargement of a portion of **Fig. 6** showing the catalyst support structure.

**Fig. 8** is a cross-section of **Fig. 5** taken through section a-a showing another embodiment for a compounded catalytic structure before firing.

**Fig. 9** is an enlargement of the circled portion of **Fig. 8** showing greater detail of the catalyst support structure.

**Fig. 10** shows what the structure of **Fig. 9** looks like after it has been fired, and the glass has been reflowed.

It is noted that the drawings of the invention are not to scale. The drawings are merely schematic representations, not intended to portray specific parameters of the invention. The drawings are intended to depict only typical embodiments of the invention, and therefore should not be considered as limiting the scope of the invention. In the drawings like numbering represents like elements between the drawings. In the drawings, like numbering represents like elements between the drawings.

## DETAILED DESCRIPTION OF THE PREFERRED EMBODIMENT

The present invention provides a gas sensor for determining gas concentrations in an air stream. Referring to **Fig. 2**, there is a preferred embodiment of the gas sensor **10**. Specifically, the gas sensor **10** has a base **12**, which has a longitudinal axis **11** oriented

CTS-1508

to be at an angle to the gas stream **27**, illustrated as generally perpendicular. There is also a reference sensor element **20** on base **12**, and a catalyzed sensor element **21** proximate the reference sensor element **20**. As known in the art, the catalyzed sensor element **21** creates an exothermic reaction upon contacting the gas stream thereby forming a heated gas stream portion **29**. The gas stream flowing past the sensor element **20** would not create a heated gas stream portion **29'**. The base also has an extension portion **16**, located between the signal conditioning circuitry **14** and the sensor regions **17**, **19**, for creating a distance between the circuitry **14** and the heated sensor regions **17**, **19**. Although extension portion **16** is illustrated as relatively short, in reality it could be relatively long to protect the circuitry **14** from the detrimental high temperatures associated with the operational temperature ranges of the sensor elements **20**, **21**. The sensor regions **17**, **19** could be operating, for example, from 200 to 500 plus degrees Celsius for proper operation. However, the conditioning circuitry **14** would need to be operated around a maximum of 150 degrees Celsius for optimum signal processing. Thus, by regulating the length of extension section **16**, it is possible to keep the signal conditioning circuitry **14** in a proper operational temperature range.

In the present embodiment, both sensor elements **20**, **21** are located upon two separate bridge sections **22a**, **22b**. Additionally, these bridge sections are isolated from any heat sink effects from the base **12** by voids **18** located on at least either side of the bridges. In this arrangement, it is possible to have both sensor elements **20**, **21** closer in temperature so that any change in electrical resistance would not be due to ambient gas stream heat. Thus, only exothermic heat from the catalytic reaction on the measuring sensor element will cause a notable difference between the two resistances of the two sensor elements. It is advantageous to have both sensor elements to be close in temperature to avoid having compensating circuitry and other means for adjusting for the temperature differences. With various designs of the bridges, voids, and sensor elements, it is possible to have temperature differences below 80 degrees Celsius and optimally below 50 degrees Celsius when operating in 200 to 600 degrees Celsius or more. It is noted that the ideal situation would be to have no difference in temperature between the sensor elements except for the exothermic catalytic reaction effects.

Of particular note, horizontal axis **13** separates sensor regions **17** and **19**. It is this separation that provides for the advantage of orientation insensitivity. Specifically, the sensor **10** may rotate about axis **11** and in no position will the heated gas stream portion **29** affect the reference non-catalyzed sensor **20**. This is a great advantage over the previous design considered by the inventors in **Fig. 1**, where the sensor is very orientation sensitive for proper operation. Of course, this situation only works if the gas stream is substantially perpendicular to the longitudinal axis **11**. Also keep in mind that the gas stream most likely will already be heated but a skilled artisan will realize that the catalytic reaction with the gas will further heat the gas stream, thus creating the "extra" or catalytically heated gas stream portion **29**.

Referring to **Fig. 3**, there is illustrated a preferred wheatstone bridge embodiment.

CTS-1508

Specifically, there is a wheatstone bridge **100** having a first and second bridge **112, 114**, a voltage source **Vs** coupled to a balancing resistor **115**, a voltage source node **116** that couples one end of the two bridges **112, 114**, and a ground **Vg** coupled to a ground node **118** that couples the other end of the two bridges **112, 114**. On each bridge are two sensor elements, a reference sensor element **122, 126**, and a catalyzed sensor element **120, 124**. Coupled between the two sensor elements are metered nodes **128, 130**. Coupled to the metered nodes is an amplifier **132**, and a voltage meter **133** coupled to the amplifier for first amplifying the analog signal and then converting the analog to a digital signal coupled to the other signal conditioning circuitry **14**. The two catalyzed sensor elements **120, 124** are located on opposite sides of the base **12** but on the same bridge **22b**, for example. The reference sensor elements **122, 126** are similarly arranged on opposite sides of the same bridge, for example bridge **22a**. Thus, all four sensor elements will be located on the end of the sensor **10** that will receive direct impact from the gas stream **27**. Of course, although the specification discusses the use of sensor elements, one skilled in the art realizes that each sensor **120, 122, 124, and 126**, is a resistor.

One skilled in the art of designing sensor circuitry will understand that the circuit **100** will create a doubling of the output that can be read by the voltage meter **133** over prior art single sensor element wheatstone bridge circuits. In operation, there are two basic conditions - inactive and active. When circuit **100** is inactive or in a starting condition, all four resistors are set to be equally charged to achieve a balanced grid. Thus, when current is applied to each bridge **112, 114**, the voltage at nodes **130** and **128** are equal.

When circuit **100** is active or when a gas stream is applied to circuit **100**, there is an increase in the temperature on resistor **120** and **124**, but no change to **122** and **126**. As discussed previously, as the temperature increases, the resistance increases. Thus, the resistances on resistors **120** and **124** are greater than resistances on resistors **122** and **126**. In an ideal setting, the resistance resistor **120** equals resistor **124**, just as the resistance on resistor **126** equals resistor **122**. Because of the increased resistances, the voltage at node **130** is less than it was before the gas was applied. However, the voltage on node **128** is greater than it was before the gas was applied, because the resistance on resistor **124** is greater than resistor **126**. In the ideal setting both nodes change the same amount but in opposite directions.

It is noted that in the prior art there is only one reference and one catalyzed sensor element and the other two resistors are fixed. It did not matter if the fixed resistors were in the bottom or the top or either side of the bridges, there would still be a shift in voltage, but it would only be one half the shift achieved by the preferred embodiment.

It is noted that the prior art has two of the wheatstone bridge resistors fixed. In other words, the fixed resistors are away from the gas and even in another chamber or on the circuit board, outside the heated environment. Thus, the prior art needs very precise temperature compensating circuitry to balance the bridges.

In the current preferred embodiment, no temperature compensating circuitry need

CTS-1508

be added to the sensor 10. By having all four resistors **120, 122, 124, and 126** in the heated gas stream, control of the temperature on all four resistors is achieved as a group. Temperature controlling circuitry is used, but the resistors on the wheatstone bridge circuit are used to create the heat by controlling the amount of current that flows therethrough. In the present design, the temperature of the sensor element doesn't have to be as accurately controlled as the prior art designs. The current invention does set a temperature, it is important to have elevated temperatures, but it is not needed to have the temperature exactly controlled, like 400 or 401 degrees Celsius. It is allowable to have, for example 400, 410 or 420 degrees Celsius and still have accurate readings, because all of the resistors are dimensionally and chemically equal. With the prior art, to have a balanced bridge, it is mandatory to accurate control of the temperature of the two non-fixed resistors - the catalyzed and reference resistors. Thus, the prior art uses heaters in the designs.

The preferred embodiment will operate over a temperature range from as low as the light off temperature of the gas to be sensed to as high as whatever temperature that would breakdown the resistance of the resistors in the wheatstone bridge. The light off temperature is that temperature needed for a gas to interact with the catalyst to create an exothermic reaction.

In operation, the preferred embodiment does use a set temperature for the sensor to operate at high temperatures. In particular, it is best to operate at temperatures hotter than the ambient temperature. The hotter than ambient controlled temperature provides a stable output. One skilled in the art will realize that resistors have the resistance change linearly as a function of increasing temperature. However, for elevated temperatures, there is a little curve to the linear function. The difference in resistance that you get for a given temperature change, gets less and less as you increase hotter and hotter. Therefore, a fixed temperature is chosen higher than expected ambient because to follow a changing high ambient temperature would lead to a gradually decreased output signal as the temperature got hotter and hotter. Thus, a predictable output signal is achieved by setting the temperature of the sensor elements to a consistent output of volts per part per million.

To achieve the relatively fixed elevated temperature, the preferred embodiment has regulated current running through the wheatstone bridge 100 to keep it at that selected temperature. Specifically, the resistors, which act as a heater when current goes through them, are turned on and off a proportional amount of time. A skilled artisan would know how to regulate the temperature by taking a voltage reading of nodes **116, and 118** and setting the total resistance of the wheatstone bridge by comparing it to the in-series resistor **115**.

One of the advantages of the preferred embodiment is that the selected temperature can be changed without changing any of the hardware, ie. resistors. Thus, by simply changing the timing programming of the heating current, most any temperature can be used for the same sensor and wheatstone bridge unlike the prior art that would require a changing of the physical resistors. A key to allowing this flexibility not previously found is

CTS-1508

that the present preferred embodiment uses the same material for each resistor, all resistors are heated the same way (in the heated gas stream 27), and trimmed to be dimensionally all the same.

5 Referring to Fig. 4, there is illustrated a housing for holding the sensor 10. In particular there is a hollow air pervious porous cap 30 for encapsulating the sensing elements 20, 21. There is also an attachment 32 for coupling the cap 30 to a spacer 34. The spacer serves the purpose of extending the electronics housing 36 far enough away from the cap 30, since the cap region is the hottest area and the housing holds the conditioning circuitry 14, which requires lower temperatures for proper operation. The electronics housing 36 protects the conditioning circuitry 14 and provides support for coupling the sensor to output wires to communicate with remote analysis circuitry (not shown). The whole assembly is mounted onto an exhaust pipe just after a catalytic converter. Of course only the porous cap 30 should be located in the exhaust pipe to remove the electronics from the hot temperatures.

10  
15 The present invention provides a gas sensor having a multilayered structure. The structure is ideally suited to sensing hydrocarbons and nitrogen oxides in an automobile exhaust system. Regarding Fig. 5, there is a plan view of the gas sensor 10 showing part of a substrate (base) 12. Substrate 12 is preferably made out of a ceramic material but other suitable dielectric materials may be used. Only the portion of substrate 12 containing a catalytic support structure 50 and glass adhesion layer 46 has been included in Fig. 5.

20  
25 The remaining portion of substrate 12 can take on any desired shape that will supply the necessary structural and thermal properties for the sensor. For instance, the structure must be strong enough to survive the shock and vibration attendant in an automobile exhaust system. In addition, the thermal properties must be such that any catalytic reactions occurring on catalytic support structure 50 can be detected by a thermally sensitive resistor element 42 located on substrate 12 (i.e. the substrate must not extract so much heat from the catalytic reaction that there is no resulting temperature increase in resistor element 42).

30 Located on substrate 12 and electrically connected to resistor element 42, are conductors 44 and 45. Conductors' 44 and 45 are connected to circuitry (not shown) that can detect resistance changes from accompanying voltage drops along the length of resistor element 42.

35 In Fig. 6, a cross section taken through resistor element 42 is depicted. Resistor element 42 can be deposited on substrate 12 using any conventional thick or thin film technique since the deposit is robust enough to withstand the environment of an auto exhaust system and the thermal coefficient of resistivity is high enough so that the resistor will respond to temperature changes from catalytic reactions. The material used to form resistor element 42 can be selected using these same criteria. In the preferred embodiment, it was found that platinum is a suitable material for resistor element 42 and that screen printing proved to be a suitable deposition method.

CTS-1503

Conductors **44** and **45** can also be deposited using any conventional thick or thin film technique. Gold was selected as the conductor material for the preferred embodiment. A layer of glass **46** is deposited over the resistor element **42**. One way of forming glass layer **46** is to mix powdered glass with an organic solvent and screen print the mixture on the substrate. The glass layer can also be formed using a doctor blade or brushing the mixture on. The layer of glass **46** is then dried but not fired yet. This provides a firm surface on which to deposit the catalytic support structure **50**, but still enables the glass to act as an adhesion promoter when the structure is subsequently fired.

The catalytic support structure **50** comprises high surface area particles such as powdered alumina. The particles can be calcined before applying them to the sensor structure to help assure that they have a high surface area for receiving a catalyst coating. The alumina particles can be combined with aluminum hydroxide or a similar substance to form a paste for application. The paste can be applied with thick film techniques such as screen printing.

After catalytic support structure **50** is applied the entire assembly is fired at the proper firing profile for the glass employed. This will reflow the glass and cause it to firmly adhere to both the alumina particles and substrate **12**. It is important that the glass bond very firmly to both the substrate and catalytic support because if the alumina particles flake off, the sensor will no longer function. In principle, any glass film formation, including many commercially available varieties such as GA-4 from Nippon Electric Glass, can be used as described above, provided it has the property of adhering to both substrate **12** and the catalytic support structure **50**. A temperature of 700 degrees centigrade for 1 hour is sufficient to reflow the GA-4 glass.

The final step is to apply a catalyst to catalytic support structure **50**. In the preferred embodiment for a hydrocarbon sensor, platinum is used for the catalyst. The platinum is applied as a chloroplatinic acid solution using a dropper or other suitable technique. Afterwards the entire structure is again fired at about 500 degrees centigrade for 1 hour to reduce the acid to platinum.

The final catalytic support structure, as shown by the enlarged view in **Fig. 7**, comprises alumina particles **54** adhered to glass layer **46**. The particles vary in size and shape and the surface may include pores **56**. When the chloroplatinic acid is applied and dried as described above, the surfaces of particles **54**, including the surfaces of pores **56**, will be covered by a very fine layer of platinum.

In **Fig. 8**, a cross section taken through resistor element **42** is depicted. Resistor element **42** can be deposited on substrate **12** using any conventional thick or thin film technique since the deposit is robust enough to withstand the environment of an auto exhaust system and the thermal coefficient of resistivity is high enough so that the resistor will respond to temperature changes from catalytic reactions on the overlaid support structure. The material used to form resistor element **42** can be selected using these same criteria. In the preferred embodiment, it was found that platinum was a satisfactory material for resistor element **42** and that screen printing proved to be a suitable deposition

CTS-1508

method.

As shown in **Fig. 9** and **10**, the catalyst support structure **64**, comprises a mixture of alumina particles **74** and powdered glass **72**. In the preferred embodiment, the mixture includes 20% LaRoche V700 alumina and 80% GA-4 glass from Nippon Electric Glass. The alumina is calcined at about 600 degrees Centigrade for 1 hour before it is added to the mixture. This helps assure that the alumina will have a high surface area for a catalyst coating. Sufficient screening agent is added to the mixture to obtain a paste like consistency. The screening agent used in the preferred embodiment is comprised of an organic solvent, a rheology modifying solid and a wetting agent.

The mixture is deposited over the resistor element **42**. Screen printing is one suitable method of depositing the mixture; although it can also be deposited using a doctor blade, brushing etc. After catalytic support structure **64** is applied, the entire assembly is heated at a temperature that will reflow the glass employed. A temperature of 700 degrees centigrade for 1 hour is sufficient to reflow the GA-4 glass **72**, and cause it to firmly adhere to both the alumina particles **74** and substrate **12** as shown in **Fig. 10**. It is important that the glass bond very firmly to both the substrate and catalytic support because if the alumina particles flake off, the sensor will no longer function.

The final step is to apply a catalyst to catalytic support structure **64**. In the preferred embodiment for a hydrocarbon sensor, platinum is used for the catalyst. The platinum is applied as a chloroplatinic acid solution using a dropper or other suitable technique. Afterwards the entire structure is reheated at a temperature that is high enough to reduce the acid to platinum. A temperature of 500 degrees centigrade was used for the preferred embodiment.

Alumina particles **74** vary in size and shape and the surface may include pores **76**. When the chloroplatinic acid is applied and dried as described above, the surfaces of particles **74**, including the surfaces of pores **76**, will be covered by a very fine layer of platinum. Of course, some platinum will also adhere to the surfaces of glass **72**.

### Operation of the Sensor

The key to the operation of the sensor is the catalytic reaction of the gas to be sensed and the ability of the resistor element to respond to this reaction by a resulting change in its resistance. For example, as a hydrocarbon gas contacts the platinum catalyst, a chemical reaction occurs in which the hydrocarbon is combusted and heat is generated. The greater the quantity of hydrocarbons, the more heat is produced, thus causing the resistance of resistor element **42** to rise accordingly. The resistance of resistor element **42** is then compared to the resistance of a reference sensor (not shown), which is in the same environment and of the same design, except that it is not covered with a catalyst. The difference in the resistance between resistor element **42** and the reference sensor (not shown) is due to the heat generated by the catalytic reaction. The resistance difference indicates the concentration of hydrocarbons in an exhaust stream.

CTS-1508

## Variations of the Preferred Embodiment

Although the illustrated embodiments discuss the arrangement of the sensor and signal conditioning circuitry **14** to be on a single base, one skilled in the art will realize that the preferred embodiment would work with most any arrangement. For example, the signal conditioning circuitry **14** could be on a separate base, where the sensor element containing base is, for example, solder connected to the signal conditioning circuit containing base. Additionally, the second base containing the conditioning circuitry could also be a printed circuit board and not ceramic material like the sensor element base.

Eventhough the disclosure discusses the sensing of hydrocarbon, one skilled in the art of gas sensors would understand that this invention is applicable to any combustible gas that is needing to be detected. For example, if hydrogen were to be detected, the heating fixed target temperature for the sensor elements could be around 100 degrees Celsius. An application for a hydrogen sensor would be around a battery enclosure. A set of batteries on an electric car could use a sensor to monitor explosive fumes. Although the preferred embodiment discusses the location of the catalyzed sensor element to be closest to the far end of the sensor, ie. sensor element **21**, it is equally workable to have the catalyzed sensor to be located furthest away from the top of the sensor base, ie. sensor elements' **20** location. Thus, a reversal of the positions of the sensor elements is often needed dependent upon the orientation of the overall gas sensor in the gas stream. In these variations, it is still possible to have the heated gas stream portion **29** not contact the reference sensor elements **20** or **21** dependent upon the orientation design.

A further variation of the preferred embodiment is to have the longitudinal axis at most any angle to the gas stream that would allow rotation about the axis that would not have the catalyzed heated gas stream portion contact the reference sensor. However, the present invention works especially well if the whole sensor were inserted into the gas stream at a right angle. However, for example, the sensor housing could be at an acute angle oriented any way in the gas stream. If oriented toward the gas stream, of course the catalyzed sensor would be located below the non-catalyzed sensor (ie. further away from the one end of the base). In this arrangement, the sensor base **12** could be rotated about the longitudinal axis without having the heated gas stream potion **29** contacting the reference sensor elements. If the acutely angled sensor housing were facing downstream, however, the catalyzed sensor element would have to be the top most element with the reference sensor receiving the gas stream **27** first.

While the invention has been taught with specific reference to these embodiments, someone skilled in the art will recognize that changes can be made in form and detail without departing from the spirit and the scope of the invention. The described embodiments are to be considered in all respects only as illustrative and not restrictive. The scope of the invention is, therefore, indicated by the appended claims rather than by the description. All changes that come within the meaning and range of equivalency of the claims are to be embraced within their scope.

CTS-1508

What is claimed and desired to be secured by United States Patent is:

1. A gas detector, comprising:
  - 5 a) a wheatstone bridge, having:
    - a1) a first and second bridge,
    - a2) a power supply node electrically coupling the first and second bridge at one end,
    - 10 a3) a ground node electrically coupling the first and second bridge at another end, and
    - a4) a first and second metered node located on the first and second bridge respectively;
  - b) a first catalytic sensor element, located on the first bridge between the power node and first metered node;
  - 15 c) a second catalytic sensor element, located on the second bridge between the ground node and second metered node;
  - d) a first reference sensor element, located on the first bridge and in series with the first catalytic sensor element, and coupled between the first metered node and the ground node; and
  - 20 e) a second reference sensor element, located on the second bridge and in series with the second catalytic sensor element, and coupled between the second metered node and the power node.
- 25 2. The gas detector of claim 1, wherein the first and second reference sensor elements are located to receive a same gas stream as the first and second catalytic sensor elements.
- 30 3. The gas detector of claim 1, wherein the gas detector further comprises a base having one end for being heated during operation of the gas detector, the wheatstone bridge located on the one end thereof.
- 35 4. The gas detector of claim 3, wherein during operation of the gas detector, a heated gas stream portion is created as the gas stream passes over the first and second catalyzed sensor element, the first and second catalyzed sensor element and the first and second sensor element are positioned on the base so that as the base rotates about the axis, the heated gas stream portion will not contact the first or second sensor element.
- 40 5. The gas detector of claim 4, wherein the base includes a catalyzed sensor section for mounting both the first and second catalyzed sensor elements on opposing sides thereof.
6. The gas detector of claim 5, wherein the base includes a sensor section for mounting

CTS-1508

both the first and second sensor elements on opposing sides thereof.

7. The gas detector of claim 6, wherein the catalyzed sensor section and the sensor section has a void on at least two sides thereof.

8. The gas detector of claim 1, wherein the gas detector further includes signal conditioning circuitry, electrically coupled to the wheatstone bridge circuit for conditioning signals from the wheatstone bridge circuit.

9. The gas detector of claim 8, wherein the base includes:

a conditioning circuitry section for mounting the conditioning circuitry on the base; and

an extension section for locating the conditioning circuitry section away from the wheatstone bridge circuit.

10. The gas detector of claim 9, wherein the conditioning circuitry section is located in a temperature range under 150 degrees Celsius.

11. A gas detector for detecting a concentration of gas in a gas stream, comprising:

a) a wheatstone bridge circuit, having:

a1) a first sensor element and a first catalyzed sensor element coupled in series on a first bridge of the wheatstone bridge circuit;

a2) a second sensor element and a second catalyzed sensor element coupled in series on a second bridge of the wheatstone bridge circuit and in opposite order to the first bridge; and

b) a base having one end for being heated during operation of the gas detector, the wheatstone bridge located on the one end thereof.

12. The gas detector of claim 11, wherein during operation of the gas detector, a heated gas stream portion is created as the gas stream passes over the first and second catalyzed sensor element, the first and second catalyzed sensor element and the first and second sensor element are positioned on the base so that as the base rotates about the axis, the heated gas stream portion will not contact the first or second sensor element.

13. The gas detector of claim 12, wherein the base includes a catalyzed sensor section for mounting both the first and second catalyzed sensor elements on opposing sides thereof.

14. The gas detector of claim 13, wherein the base includes a sensor section for mounting both the first and second sensor elements on opposing sides thereof.

15. The gas detector of claim 14, wherein the catalyzed sensor section and the sensor

CTS-1508

section has a void on at least two sides thereof.

5 16. The gas detector of claim 11, wherein the gas detector further includes signal conditioning circuitry, electrically coupled to the wheatstone bridge circuit, for conditioning signals from the wheatstone bridge circuit.

10 17. The gas detector of claim 16, wherein the base includes:  
a conditioning circuitry section for mounting the conditioning circuitry on the base;  
and  
an extension section for locating the conditioning circuitry section away from the wheatstone bridge circuit.

18. The gas detector of claim 17, wherein the conditioning circuitry section is located in a temperature range under 150 degrees Celsius.

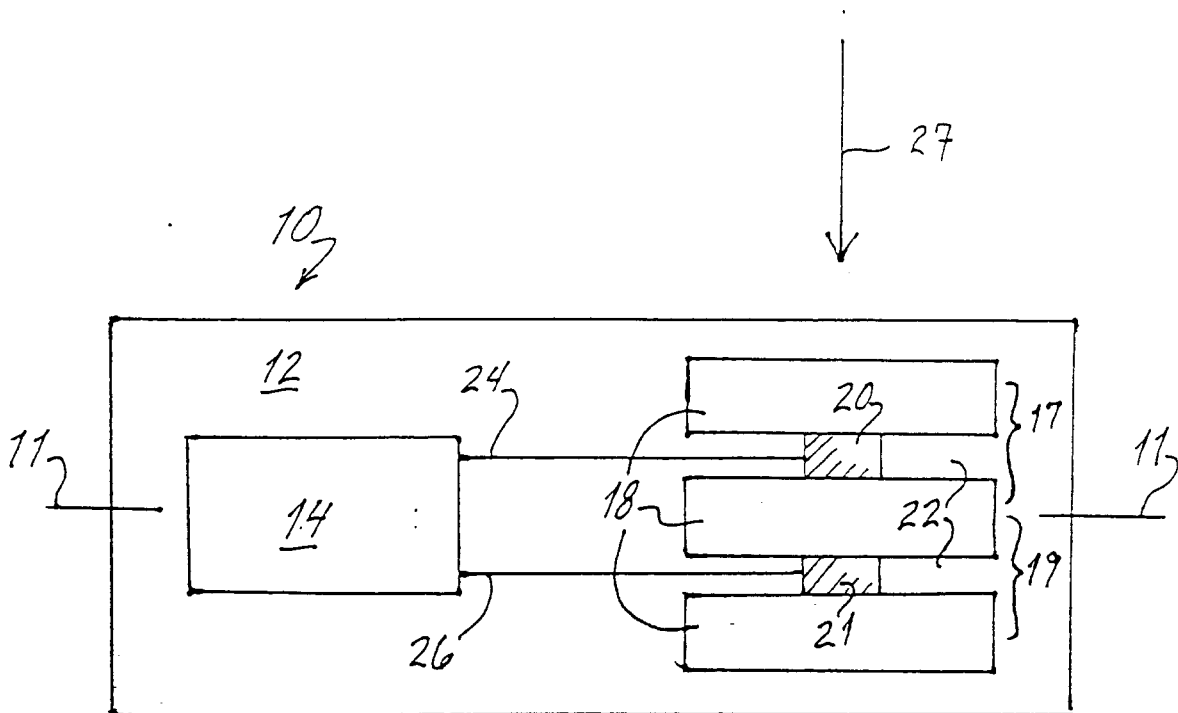

Fig. 1  
( Related Art )

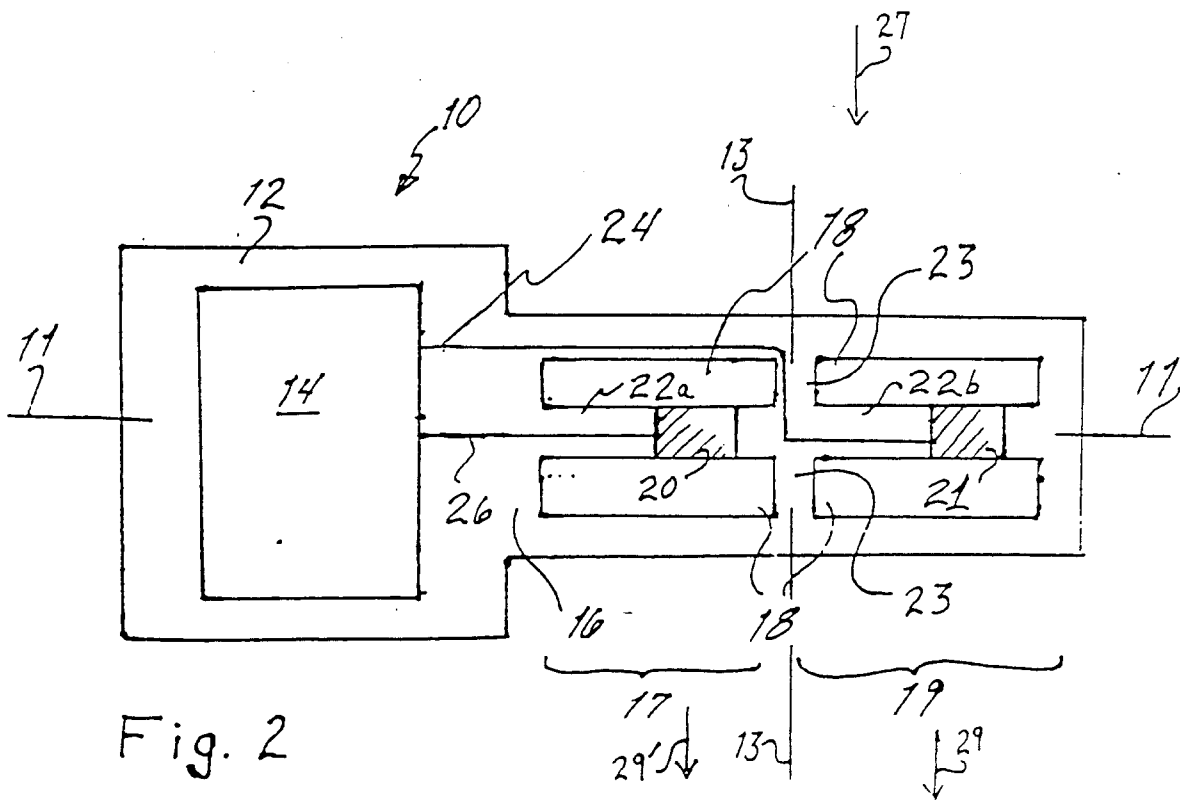

Fig. 2

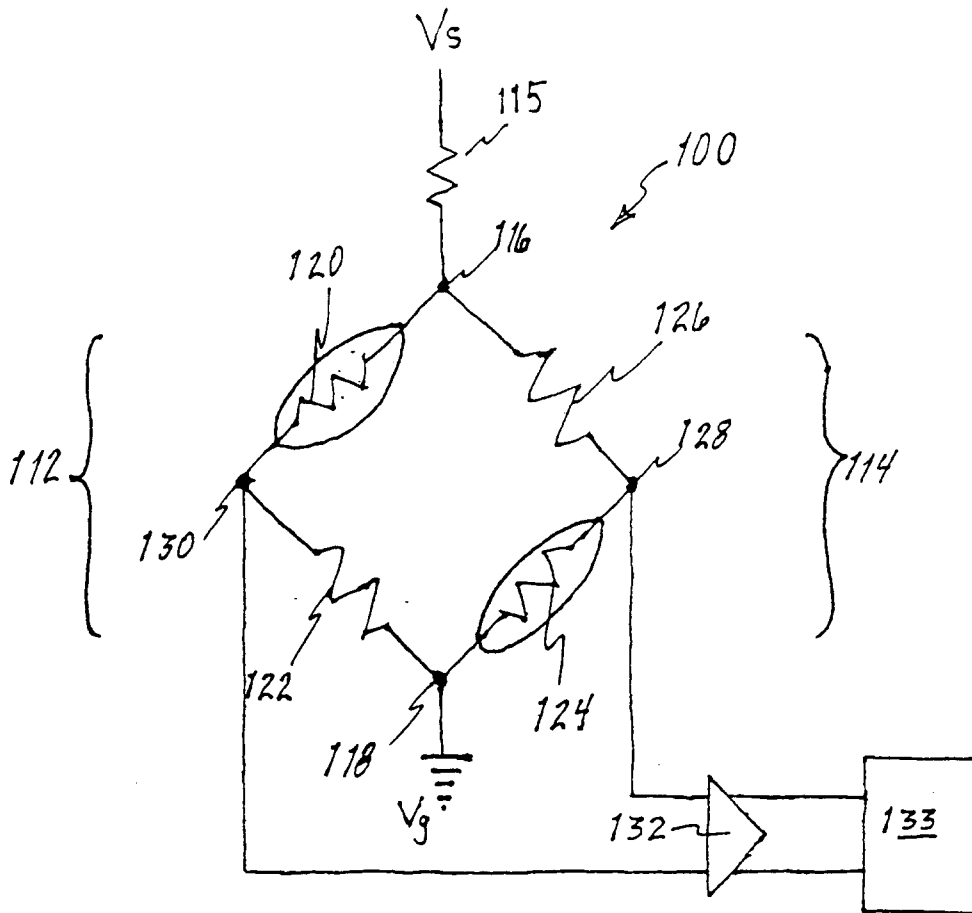

Fig. 3

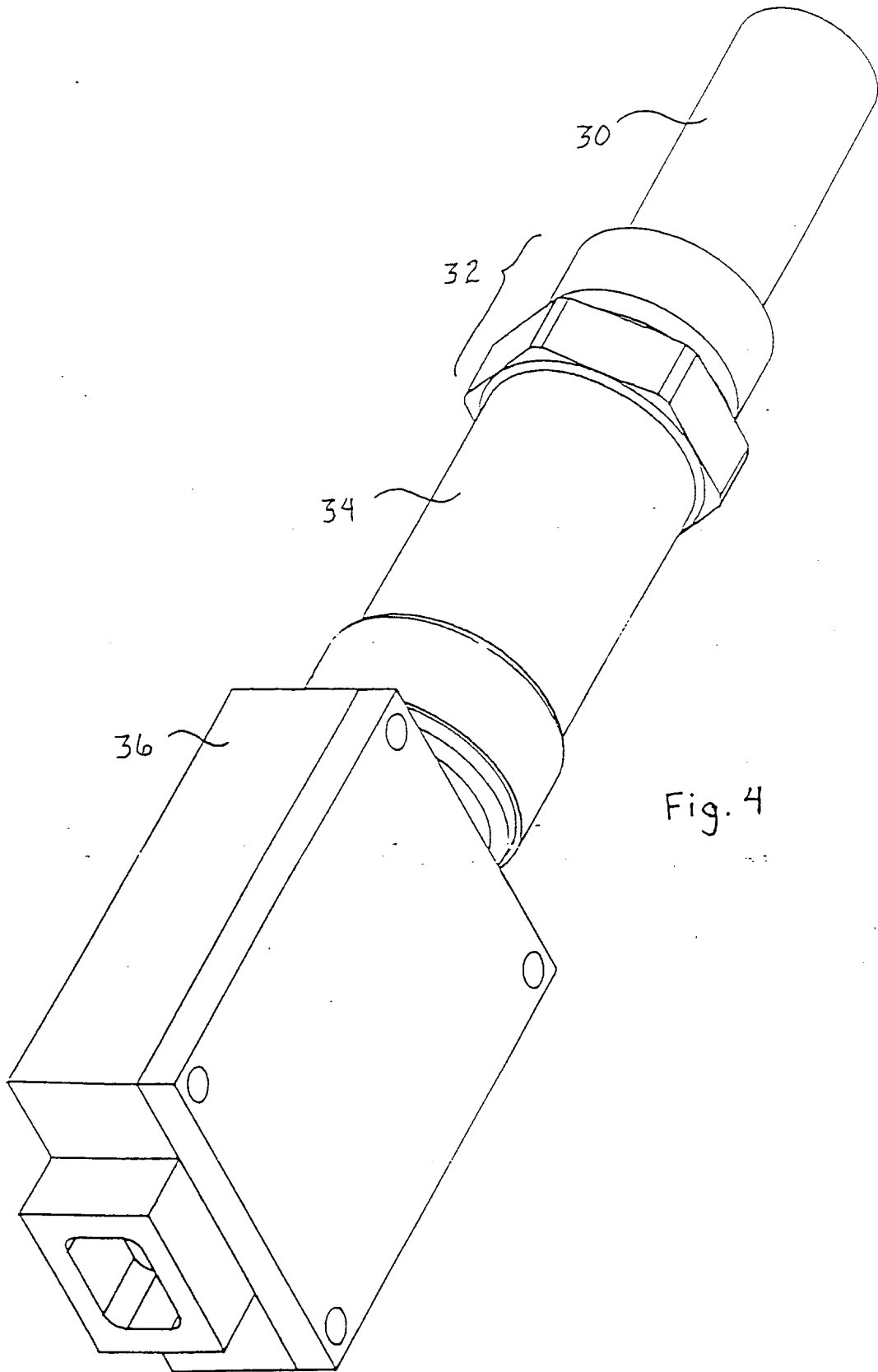

Fig. 4

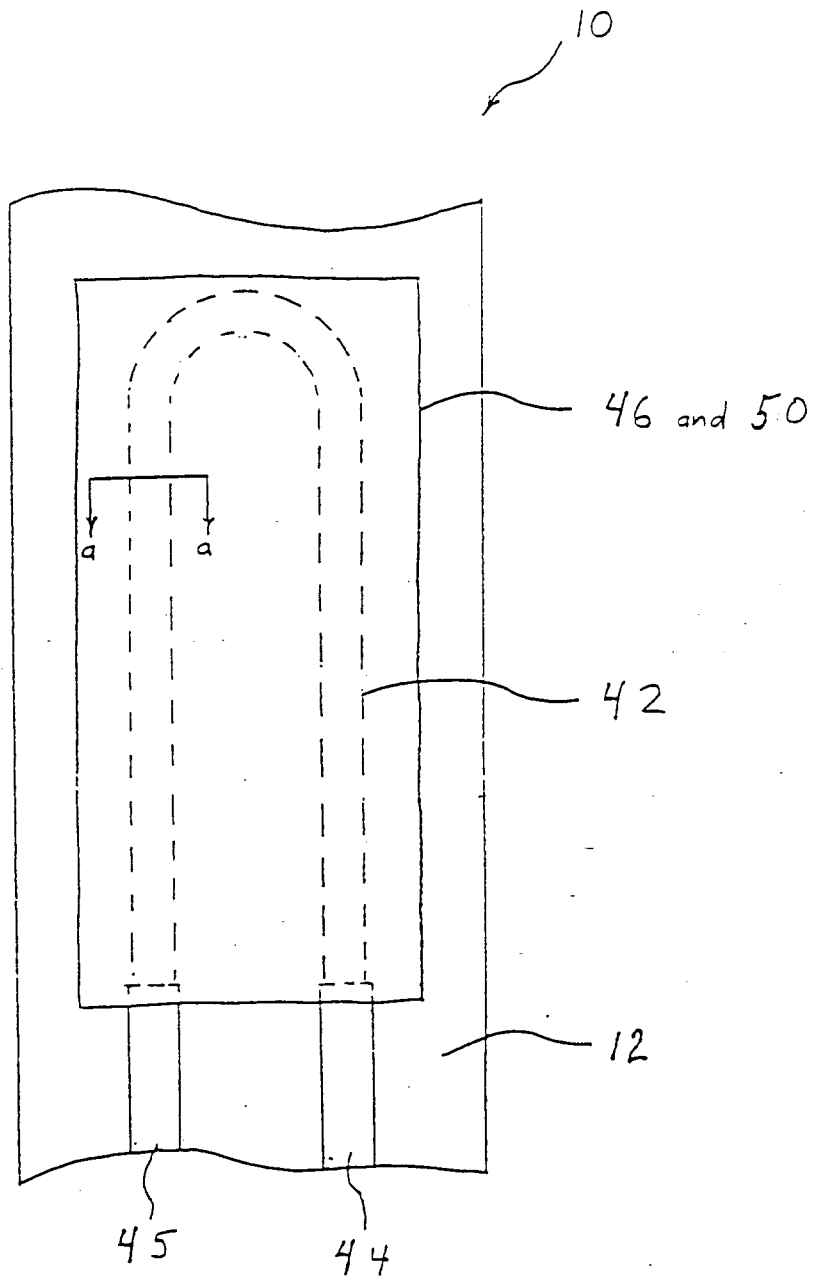

FIG. 5

FIG. 7

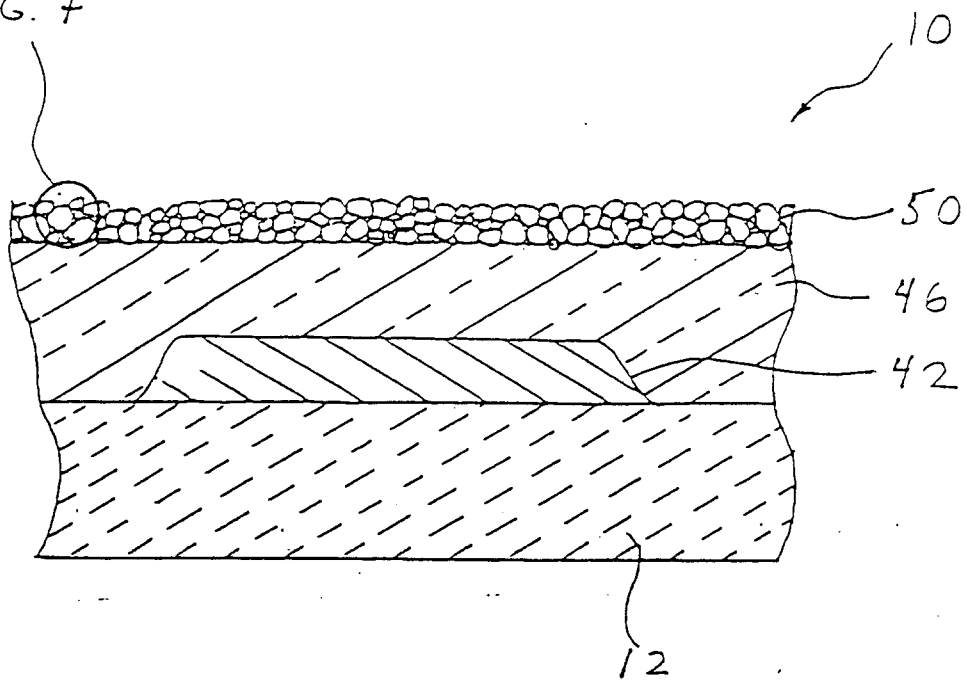

FIG. 6

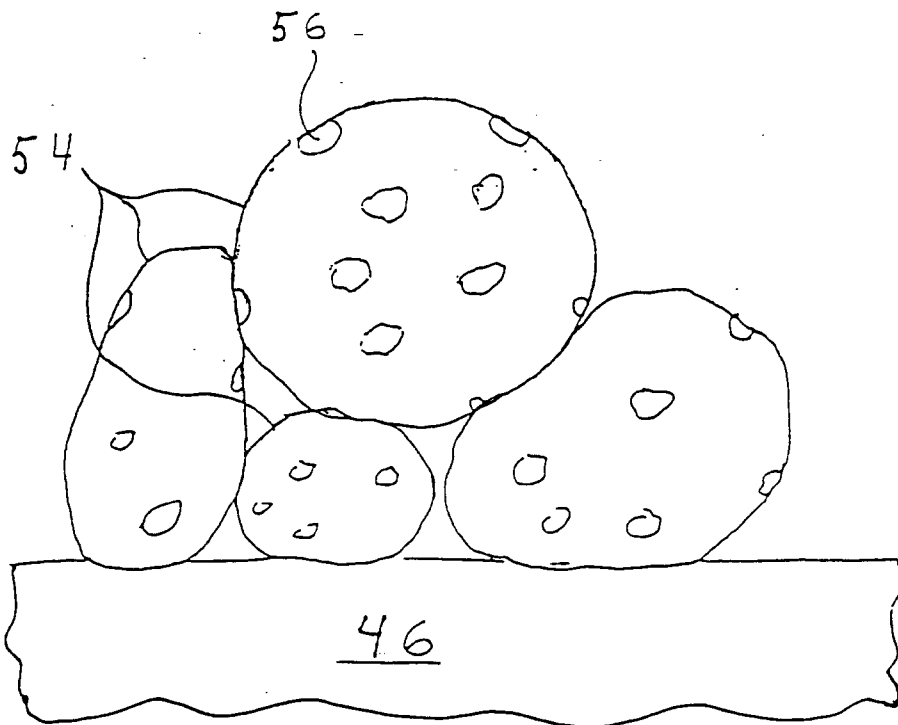

FIG. 7

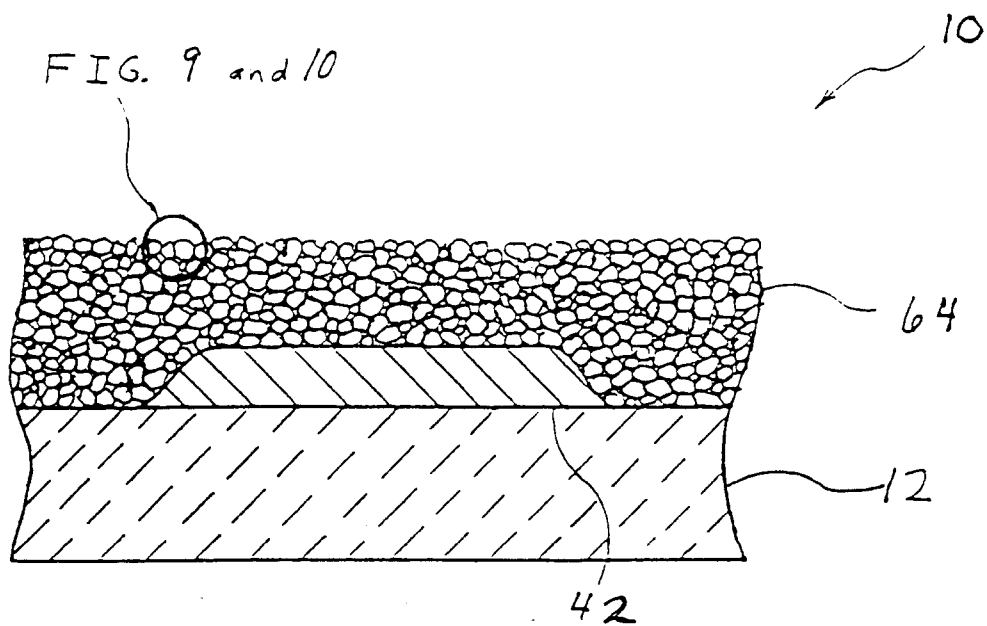

FIG. 8

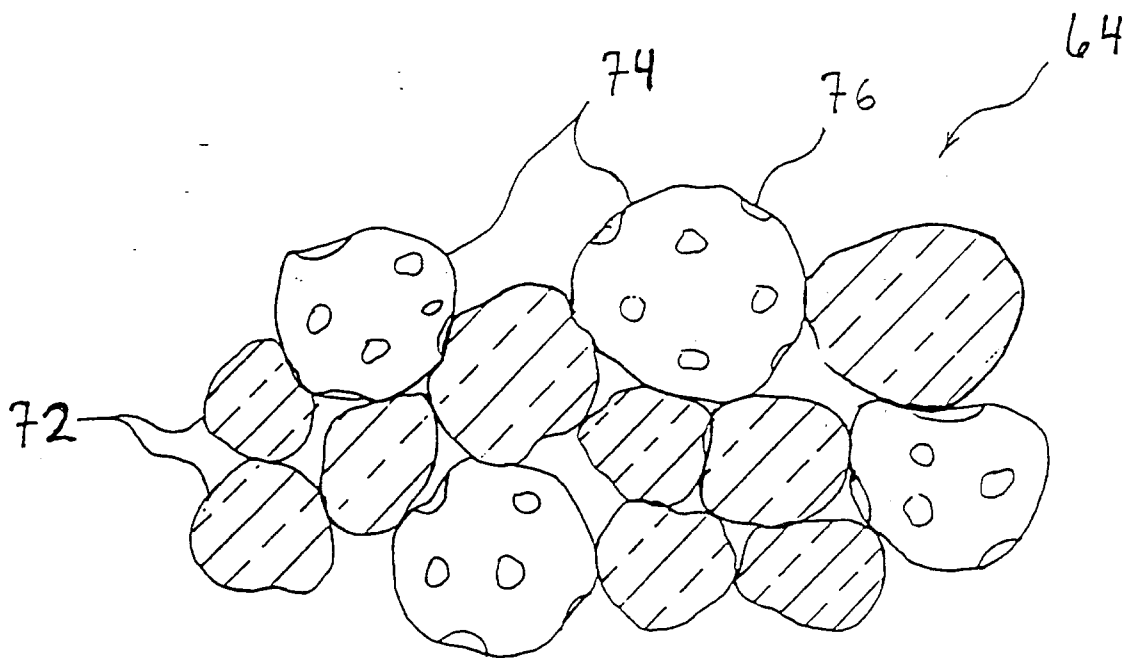

FIG. 9

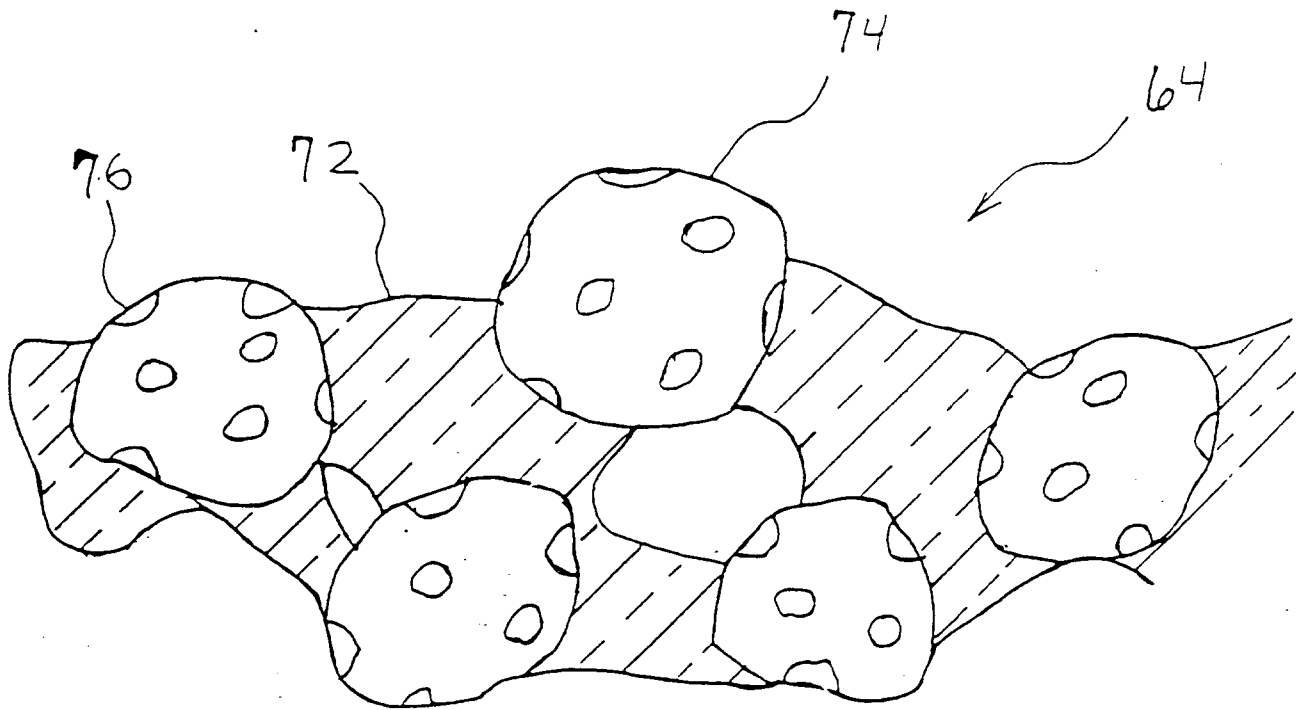

FIG. 10

