

No. 646,007.

Patented Mar. 27, 1900.

R. M. MCBETH.
MECHANICAL DRAFT AND UNDERFEED STOKER.

(Application filed July 1, 1898.)

(No Model.)

2 Sheets—Sheet 1.

Fig. 1

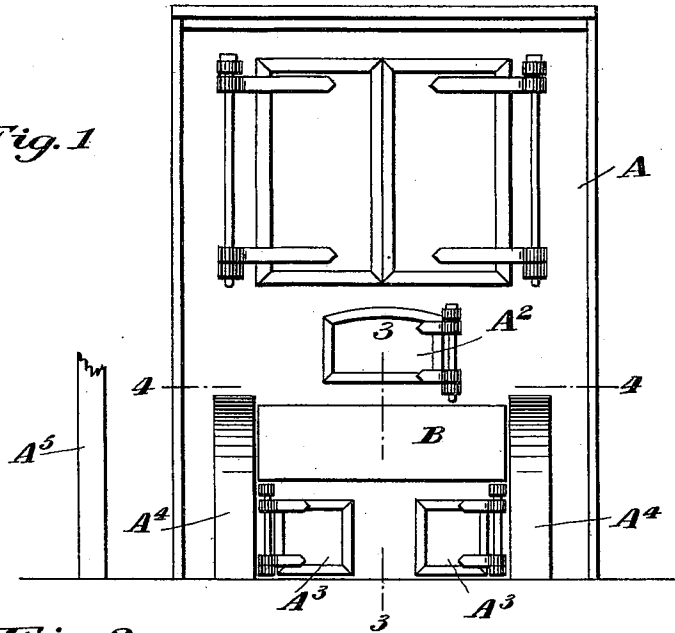
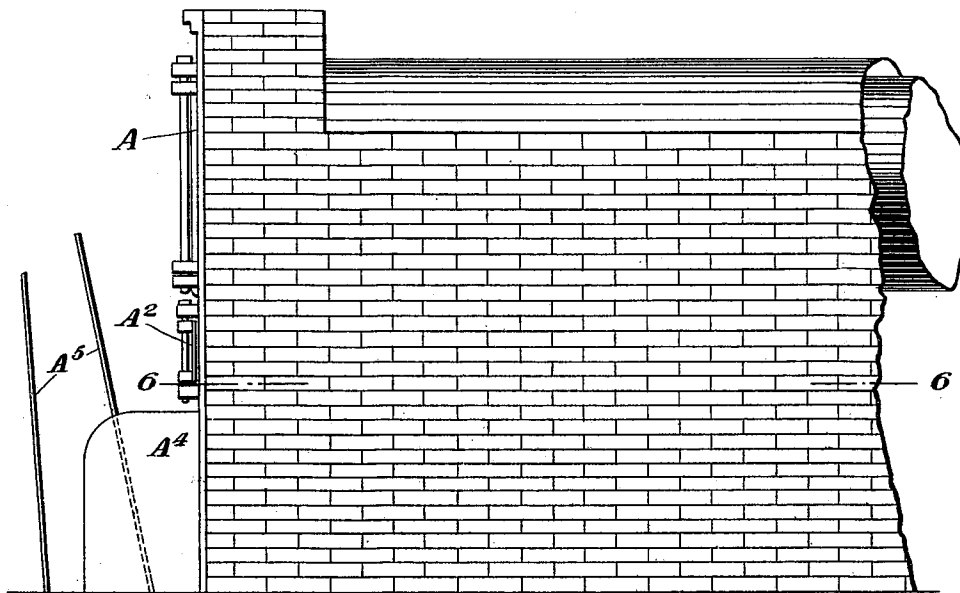

Fig. 2



Witnesses
Charles H. Spingel,
K. Smith,

Inventor
Robert M. McBeth
per Wm. Hubbell Fisher,
Atty.

No. 646,007.

Patented Mar. 27, 1900.

R. M. McBETH.

MECHANICAL DRAFT AND UNDERFEED STOKER.

(Application filed July 1, 1898.)

(No Model.)

2 Sheets—Sheet 2.

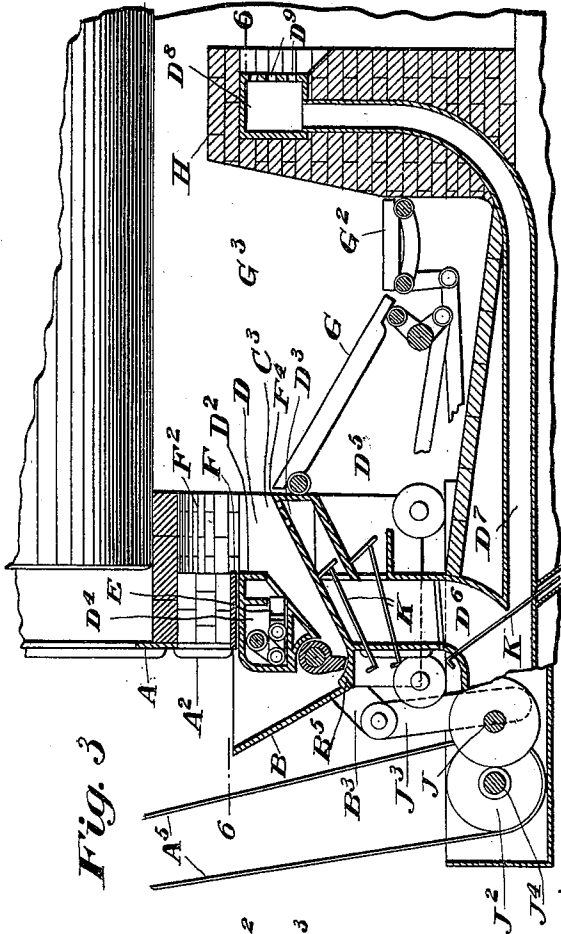

Fig. 3

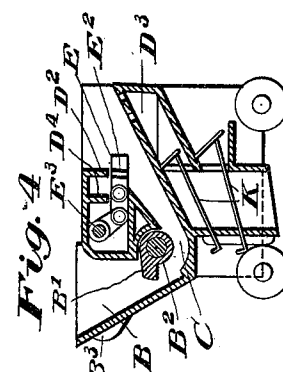

Fig. 4

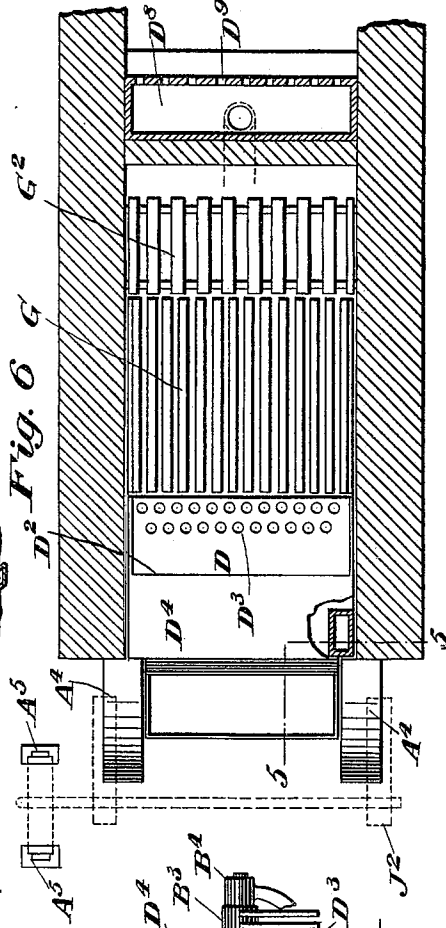

Fig. 5

Witnesses
 Charles H. Spizel.
 N. Smith

Inventor
 Robert M. McBeth
 per Wm. Hubbell Fisher,
 Atty.

UNITED STATES PATENT OFFICE.

ROBERT M. MCBETH, OF CINCINNATI, OHIO.

MECHANICAL DRAFT AND UNDERFEED STOKER.

SPECIFICATION forming part of Letters Patent No. 646,007, dated March 27, 1900.

Application filed July 1, 1898. Serial No. 684,963. (No model.)

To all whom it may concern:

Be it known that I, ROBERT M. MCBETH, a citizen of the United States, and a resident of the city of Cincinnati, in the county of Hamilton and State of Ohio, have invented certain new and useful Improvements in Mechanical Draft and Underfeed Stokers designed to Burn Slack or Slack and Nut Coal in Steam-Boiler and other Furnaces, of which the following is a specification.

The several features of my invention and the various advantages resulting from their use conjointly or otherwise will be apparent from the following description and claims.

Figure 1, Sheet 1, is a front and Fig. 2 is a side elevation of a tubular-boiler fire-front, showing my stoker as applied to a boiler-furnace. Fig. 3, Sheet 2, is a view partly in elevation and partly in section, the section being a vertical longitudinal one taken in the plane of the dotted line 3 3 of Fig. 1, that part of the section being shown which lies to the left of the dotted line 3 3, the housings A⁴ being removed. Fig. 4 is a longitudinal section in elevation, taken in the plane of the dotted line 4 4 of Fig. 5 and is partly in section and partly in elevation, that part of the section being shown which lies to the left of the dotted line 4 4. Fig. 5, Sheet 2, is in general a front elevation of the self-contained stoker. In this view the housings A⁴ and a part of the front casing, &c., have been removed to disclose the parts behind. Fig. 6 is a longitudinal section of the furnace, taken in the plane of the dotted line 6 6 of Figs 2 and 3 and showing that part or plan of the machine which is disclosed when all above the plane of the dotted line 6 6 is removed.

The stoker is a self-contained automatic machine mounted on truck-wheels for feeding fuel into boiler and other furnace fires, with none of the working parts on the inside of the furnace, and consists of a fuel-magazine coking-retort which connects the bottom of the magazine with the bottom of the retort, a fuel-feeder and coal-crusher at the bottom of the fuel-magazine and abreast of the retort-mouth, a retort fuel-agitator, twyers for supplying air to the fuel in the retort, a wind-box for supplying air to the twyers and a fire-chamber G³ and inclined moving grate-bars, and an ash-pit D⁵, from

which air is passed upward between the grate-bars to the incandescent fuel after it has been discharged from retort onto the inclined rocking grate-bars G by the action of the retort fuel-agitator E and the fresh fuel which is constantly entering the retort at its bottom. Air is also delivered back of the bridge-wall, but is taken direct from the blast-pipe and regulated by a valve. The inclined rocking grate-bars are independent of the self-contained machine.

Prominent among the various well-known methods of assisting in the combustion of coal and the prevention of smoke that I am able to take advantage of, in combination with the improvements which I have made, in underfeed stokers are moving grate-bars and fresh air introduced behind the bridge-wall.

The object in mounting the machine (stoker) on truck-wheels is to provide a quick means of inspection and also to facilitate repairs of the machine and of the walls of the furnace. When such work becomes necessary, the machine is drawn out onto the boiler-room floor, Fig. 4, Sheet 2, and as the stoker forms the largest part the furnace fire-front below the boiler it gives when removed the largest possible amount of room for the workman to make repairs to the furnace-walls, and when the machine is out on the floor there is no part to which access cannot be had with ease.

Experience has shown that underfeed mechanical - draft stokers as heretofore constructed give out in their most vital parts and are very difficult and expensive to repair. The twyers and other parts exposed to the action of the heat are fixed and on the inside of the furnace and are not accessible except when the furnace is cold, and under the best conditions the space to make repairs is very limited, and all of the air required for the combustion of the fuel is made to pass through the twyers, which are parallel with and on the inside of the furnace. The tendency of this system is to create an excessive heat in the center of the furnace, thereby increasing the liability of damage to the boiler, twyers, retort, and dead-plates. This system also makes it necessary to use dead-plates in place of grate-bars. The objections to dead-plates

in place of grate-bars are that they warp from the heat of the furnace and they shut off all connection between the ash-pit and furnace-fire, making it impossible to keep the fires
 5 clean while the furnace is in action, and a large part of the ash must pass over the bridge-wall and fill up the space behind the wall. In my stoker all of the vital parts are included in the self-contained machine and are
 10 not exposed to the intense heat of the furnace and in case of accident can be removed and repaired while the furnace is in action. The fact that the vital working parts which are exposed to the heat do not come in contact
 15 with the greatest heat of the furnace, but are at the coolest part of the latter, insures for them a greater length of life. Furthermore, it is to be observed that a very small part of the machine is so exposed, and such small
 20 part consists of the retort and retort fuel-agitator, and in case of accident these two last-named could be dispensed with and yet obtain good results by hand-stoking without drawing fires.

25 In the use of grate-bars there is a very great advantage over the dead-plate system, as the best results cannot be obtained with a constant accumulation of cinder and ash in the furnace-fires. In my stoker the fires are kept
 30 clean and free from cinder and ash by the inclined moving grate-bars. The movement also breaks up the clinker, which is the cause of much trouble in other underfeed stokers.

The most important feature of my invention and that which enables me to accomplish the various important results in combustion is the transverse underfeed, which consists in feeding fuel into a coking-retort at right angles to the axis of the retort and in the direction of the draft of the furnace, substantially as shown, the main object hereof being to effect an intimate previous mixture of fresh air with the hot gases in that part of the furnace to which they naturally rise.
 45 This system enables me to place the magazine and retort and other parts of the magazine, in combination with the mechanical draft, in such a position as to obtain the proper mixture of fresh air with the gases which are
 50 generated at different stages of combustion and must have the proper proportion of fresh air at the time and at the part of the furnace in which the gas is generated and independent of the other gases in order to effect perfect
 55 combustion, and when this is not done a large amount of useful heat is lost by the gases which escape unburned but without visible smoke.

It is not necessary to use mechanical draft with my machine. Natural draft may be used. Mechanical draft is preferred, because the amount and distribution of the air are under perfect control. From the many variations of the detailed structures which may be employed in carrying mechanical draft into effect I have selected one form for the illustration of the complete operation of my ma-

chine. It is impossible for air passed through fuel in one stage of combustion to meet the requirements of the gases generated in another stage of combustion. Hence the necessity of a means for introducing fresh air at the time and places required.

I will now proceed to particularly describe the various portions of the machine under consideration.

A indicates the fire-front, A² the hand feed-doors, and A⁴ the housings.

F is the fire-brick lining of the fire-front, and F² the fire-brick roof over the retort.

Inside the magazine B and at the bottom thereto there is a fuel-feeder and coal-crusher with an oscillating movement operated by the bell-crank arm B³, Fig. 5. There is preferably such an arm B³ at each end of the magazine B, and the free end of this arm is connected to a spur-gear crank-wheel J, Fig. 3, which is under the floor, by a rod J³. The crank-wheel J receives its motion from a pinion J² on shaft J⁴, the latter driven by a belt A⁵ or small engine at one side of the furnace, Fig. 3 and Fig. 1, Sheet 1. The gear of crank-wheel J and pinion J² are shown conventionally.

I place the fuel-magazine B and retort D, Fig. 6, Sheet 2, across the front of the fire-chamber of a furnace, the fire-chamber being provided with inclined rocking grate-bars G and connect the bottom of the magazine with the bottom of the retort by means of the retort-mouth C, Fig. 4. The magazine retort-mouth and retort are equal in length, and the length of the retort is equal to the width or size of the furnace. At the mouth C of the retort and abreast of the same there is a coal feeder and crusher B' and B², with an oscillating or reciprocating movement. The feeder in form is a long cylinder B², with an exterior tooth B' (the face of which is equal in length to the retort-mouth) for the purpose of forcing the fuel by successive charges from the magazine into the retort D. It is not necessary that the feeder and crusher be of the shape shown and described. This form is preferred because it works with less friction than any other. Any form of feeder may be employed competent to carry into effect the several features of my invention. The feeder is supported by journals B⁴, Fig. 5, one at each end, and when the mouth of the retort is to be charged with fuel the tooth B' is elevated (see Fig. 4) and the fine slack and nut fuel in the magazine B will fall under the tooth B' by gravity and fill the space left by the withdrawal of the tooth, and when the tooth descends (see Fig. 3) any coal too large to enter the mouth C of the retort will be crushed between the abutment-walls B⁵ of the magazine and the feeder-tooth B', and all of the coal before the tooth will be forced on and into the retort-mouth C and from the retort-mouth into the retort D by the successive charges which enters the mouth of the retort C, and I am enabled to deliver and maintain

by this means a continuous flow of fine fuel (slack) in a thin stream from the bottom of the magazine B to the retort D. This stream of fuel presents its broad side, as it were, or edge (at the delivery side C³ of the retort-mouth) to the incandescent fuel in the coking portion F⁴ of the retort D, and as the fresh fuel comes in contact with the incandescent fuel coal-gas is generated, and the required intimate mixture of fresh air for this gas is principally obtained through the twyers D², Figs. 3 and 4, and as the fuel enters the coking portion of the retort from the bottom upward simultaneously throughout its entire length I am enabled to maintain a uniform depth of incandescent fuel and heat in the retort, which is a vital point in the expulsion and consumption of coal-gas, and as the fuel in the retort works upward (from the bottom of the retort) it ceases to evolve coal-gas, and the fuel in the retort will be in an incandescent state. As fast as this takes place it is fed over onto the inclined grate-bars B by the combined action of the retort-agitator E and the fuel which is forced into the bottom of the retort by the oscillating or reciprocating feeder, and by means of this combination of the transverse feeder and retort-agitator I am enabled to keep a uniform depth of incandescent fuel on the grate-bars, and by the movement of the bars the fuel on the bars is kept free from ash and cinder. This large body of incandescent fuel on the bars will require a large amount of fresh air to complete its combustion. This air is passed upward between the grate-bars from the ash-pit D⁵ below. There will still be a large amount of useful gas generated from the fuel on the grate-bars while the combustion of the same is being completed that will be lost unless it meets with the required mixture of fresh air to effect its combustion, and, as heretofore shown, this fresh air cannot be passed through the grate-bars for this particular gas; so I introduce the required air behind the bridge-wall by means of and in combination with the mechanical draft D⁷ and an air-box D⁸ with a large number of small holes D⁹, located near the top of and in the bridge H. The retort-agitator E has a reciprocating movement transmitted through a bell-crank E³, connected with the arm B³, which operates the fuel-feeder, and the agitator works alternately with the feeding-tooth B⁷ of the feed-cylinder B². When the feeder-tooth begins to push a charge of fuel into the retort-mouth, the agitator is withdrawn into the wind-box D⁴, Fig. 3, so that the fuel in the retort may not be obstructed in its ascent. By reason of the tapering shape of the retort there is no tendency of the fuel to work back toward the magazine when the feeder-tooth is withdrawn, and as the feeder-tooth is withdrawn the retort-agitator is projected into the retort D, Fig. 4, and the incandescent fuel pushed over onto the grate-

bars and in combination with the moving grate-bars and the agitator. The fuel is kept in motion until combustion is completed. This agitator E, Fig. 4, Sheet 2, may be made in several ways. The preferred way is to insert a number of steel or iron pins into a flat bar in the same manner as a garden-rake is made, but much larger and in sections. It may also be made of cast-iron and connected with a bell-crank shaft E³, Figs. 4 and 5, Sheet 2. The entire agitator, except bell-crank, is incased inside of the wind-box D⁴, which supplies air to the side or top twyers D². The agitator points, pins, or pokers pass through the twyers, all parts of the agitator being surrounded by cold air at all times.

By reason of the reciprocating agitator and inclined rocking grate-bars the clinkers will collect in small pieces on the dumping grate-bars G², and access to the dumping-bars can be had at any time through the ash-doors A³, Fig. 1, Sheet 1, and Fig. 5, Sheet 2.

When mechanical blast is used, the air required for this furnace is preferably supplied from a blower through pipes D⁶ and D⁷ and is regulated by valves K in the pipe and wind-boxes.

In Fig. 6, which, as aforementioned, is a plan part in section, taken in the plane of the dotted line 4 4, Figs. 1 and 2, Sheet 1, side walls of and bridge-wall being in section, the magazine B, wind-box D⁴, retort D, grate-bars G and G², and wind-box D⁸ are exposed to view, also the housings A⁴ and pinion-shaft J² in dotted lines, and also two rows of twyers D² and D³. The twyers D² insure an intimate mixture of fresh air with the coal-gas, while the twyers D³ are designed to furnish that required for the incandescent fuel in the retort D.

Inasmuch as all of the machinery for feeding the coal forward is incased, an obvious advantage derived is that no coal is lost, all waste is prevented, and even that dust from the coal which arises from the operation of the machine is all fed into the fire and consumed and its heat utilized.

In operating the stoker the fires are started in about the same manner as in a common furnace, and coal is put in through the hand-feed door A², Fig. 1, Sheet 1, care being taken to obtain a bed of incandescent fuel in the retort as soon as possible, and when there is sufficient steam to run the small special engine for the blower and stoker machinery the fuel-magazine B is filled with slack or nut coal and the machinery started.

What I claim as new and of my invention, and desire to secure by Letters Patent, is—

1. An underfeed stoker with the longitudinal axes of the fuel-magazine feeder and retort of the same placed across the front of the fire-chamber of a furnace and arranged to feed fuel into the retort transversely to the axis of the retort, and causing the fuel after it enters the retort to overflow the retort broadside into the fire-chamber, and in the

direction of the draft of the furnace, and giving an evenly-distributed bed of incandescent fuel between the side walls of the fire-chamber and from the retort at the front of the fire-chamber back to the bridge-wall, substantially as and for the purposes specified.

2. In a furnace, the combination of a retort and an underfeed thereto consisting of a cylinder provided with an exterior tooth, and a curved wall, and an abutment adjoining said wall, the cylinder and its tooth arranged so that in its oscillation it will crush any coal too large to enter the retort against the abutment, and convey all of the crushed coal to the retort, substantially as and for the purposes specified.

3. In a furnace, the transverse underfeed, a retort and an agitator, adapted to agitate the fuel as it rises into the retort, and to assist in feeding it toward the rear of the furnace, substantially as and for the purposes specified.

4. In a furnace, the transverse underfeed, and a retort and an agitator, adapted to agitate the fuel as it rises into the retort, and to assist in feeding it toward the rear of the furnace, and twyers located in the coking portion of the retort, for supplying fresh air to the fuel, while being agitated by the agitator, substantially as and for the purposes specified.

5. In a furnace, an underfeed, and a retort and an agitator, adapted to agitate the fuel as it rises into the retort, and to assist in feeding it toward the rear of the furnace, and twyers located at the coking portion of the retort, for supplying fresh air to the fuel, while being agitated by the agitator, an air-chamber supplied with an air-blast, and embracing the agitator for keeping the agitator cool, and supplying the upper portion of the coking-chamber with air, substantially as and for the purposes specified.

6. In a furnace, an underfeed, and a retort and twyers located in the coking portion of the retort, for supplying the fresh air necessary for the coking process, and thoroughly distributing the same through the fuel from the bottom thereof, and upper twyers or air-blast in connection with the upper portion of the coking-chamber for supplying the latter with fresh air, substantially as and for the purposes specified.

7. The combination of a retort, whose mouth is long and narrow, in combination with a long fuel-feeder, substantially parallel thereto, and crusher of cylindrical form having a projecting tooth whose face is about equal in length to the retort and retort-mouth and parallel thereto, and feeding the fuel direct from the magazine through the retort-mouth and into the retort, substantially as and for the purposes specified.

8. The combination of a retort, and a magazine, and an underfeeder for feeding the fuel from the magazine to the retort, parallel to

each other, the retort and magazine outer walls, ends and bottoms being closed and connected, the inside wall of retort, which forms the partition between the retort and magazine having a long narrow mouth, below the fire-line, and the feeder being located at that mouth, and adapted to feed the fuel into the mouth transversely from the magazine to the latter, substantially as and for the purposes specified.

9. The combination of the retort having a long mouth, and twyers, located along each side of the retort, and wind-boxes under the twyers for supplying air to the same, and a magazine, parallel to each other, the magazine being connected to the mouth of the retort, and a long fuel-feeder acting abreast of the mouth of the retort, and transversely feeding the fuel into the mouth of the retort, substantially as and for the purposes specified.

10. The combination of the retort and magazine with sides, ends and bottom closed, an inside partition-wall between the retort and magazine, having a long mouth below fire-line, and a magazine parallel to same, and connected to the mouth of the retort, and a fuel-feeder acting abreast of the mouth of the retort, and adapted to feed the fuel into the retort transversely to the length of the latter, substantially as and for the purposes specified.

11. In a retort with a long narrow mouth, located at the bottom of the side of the retort, and extending throughout the length of its side, an oblong fuel-magazine along the side of and parallel with the retort, and connected at the bottom thereto, with the bottom side or edge of the mouth of the retort, a transverse fuel-feeder B' and B² located at the bottom of the magazine and abreast of said retort-mouth, feeding the fuel from the bottom of the magazine into the retort-mouth, and adapted to move the fuel from the magazine into the retort in a direction transverse to the length of the magazine and the retort, and after the fuel enters the retort, the movement is from the bottom upward to the fire-level at the top of the retort, substantially as and for the purposes specified.

12. The combination of a retort with a long side opening or mouth at the bottom of the same, a fuel-magazine lying alongside of the retort-opening, and connected at its bottom, with the retort at the bottom edge of the side opening or mouth of the retort, a transverse underfeeder located at the bottom of magazine and abreast of the said side opening or mouth, feeding the fuel into the retort through the side opening or mouth, and by successive charges forcing the fuel in the retort to move from the bottom upward until it reaches the twyers located at each side of the coking portion of the retort, substantially as and for the purposes specified.

13. In a transverse underfeeding stoking-machine, a retort and magazine placed side

by side, the outside walls of the same being
connected at the bottom and the walls of one
side of the retort forming a partition between
the magazine and retort and a long narrow
5 mouth (which I call the "retort-mouth") at
the bottom of the said partition-wall through
which fuel is fed broadside or transversely
from the magazine into the retort by means
of a cylinder with a fixed projecting tooth,

the cylinder having an oscillating or recipro- ro
cating movement and so arranged that when
in motion said tooth alternately closes and
opens the retort-mouth, substantially as and
for the purposes specified.

ROBERT M. McBETH.

Attest:

WALTER A. RYAN,
K. SMITH.