

Aug. 2, 1938.

F. P. HEALY

2,125,442

VALVE REGRINDING DEVICE

Filed Dec. 23, 1936

Fig. 1.

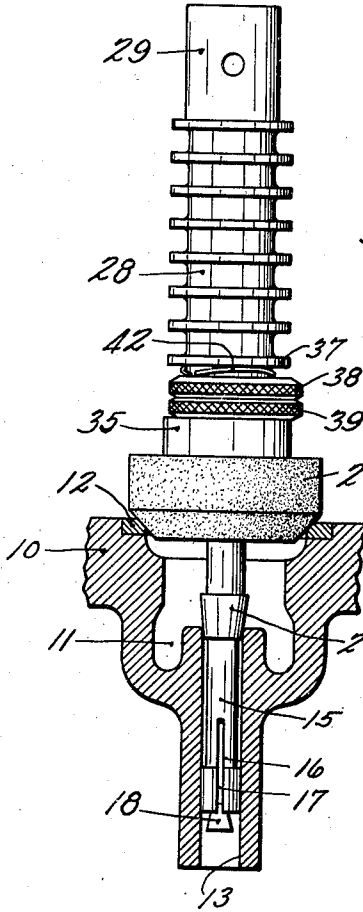

Fig. 3.

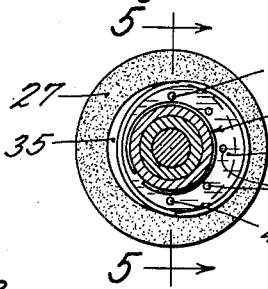

Fig. 2.

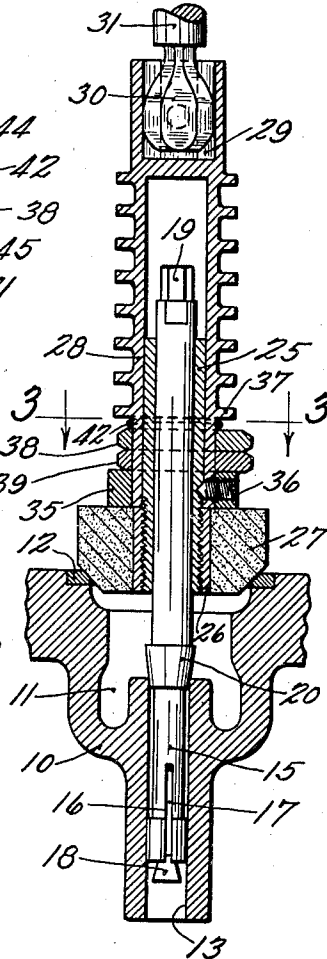

Fig. 4.

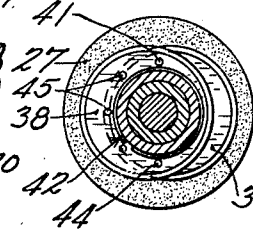

Fig. 6.

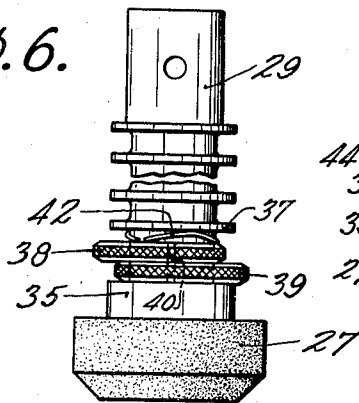
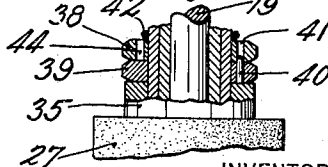

Fig. 5.



INVENTOR
FRANCIS P. HEALY
BY
Chapin & Healy
ATTORNEYS

UNITED STATES PATENT OFFICE

2,125,442

VALVE REGRINDING DEVICE

Francis P. Healy, Springfield, Mass., assignor to
Van Norman Machine Tool Company, Spring-
field, Mass., a corporation of Massachusetts

Application December 23, 1936, Serial No. 117,377

2 Claims. (Cl. 51—241)

This invention relates to a device for grinding valve seats and is in the nature of an improvement on the device shown in prior Patent 1,975,985.

One object of the present invention is to provide a device having the advantages in operation of the device of said patent with the added advantage of greater adaptability to particular conditions of operation.

A further object is to provide a simpler and more easily manipulated device of this character.

In the accompanying drawing,

Fig. 1 is a side elevation of a device embodying the present invention;

Fig. 2 is a central section through the device;

Fig. 3 is a sectional view substantially on line 3—3 of Fig. 2;

Fig. 4 is a view similar to Fig. 3 but showing the parts positioned for a different form of operation;

Fig. 5 is a sectional view substantially on line 5—5 of Fig. 3; and

Fig. 6 is a side elevation of the device with the parts in the position of Fig. 4.

Referring to the drawing, the engine block which is to have its valve seats ground, is indicated at 10 with the valve port shown at 11, and the valve seat at 12. This seat is shown as conical, but it will be understood that its form may vary. Below the seat is a guide 13 in which the valve stem runs. To form a bearing upon which the grinding wheel may turn in accurate alignment with the guide, an expansible pilot is provided which may be of any suitable type. A standard form of pilot is shown, comprising an arbor 15 split at 16 at its lower end, and a rod 17 with a conical lower end 18 adapted to be drawn upwardly by a cap 19 threaded onto the upper end of the rod. As the rod is drawn up, its conical end expands the split lower end of the arbor 15, clamping it firmly in the valve stem guide, the middle portion of the arbor being centered by a conical portion 20.

Upon the upper portion of the stationary shaft thus provided, the driving arbor of the grinding wheel is journaled. This driving arbor comprises a sleeve 25 rotatably engaging the upper end of the pilot, preferably with no more clearance than is required for a free running fit. The lower end of sleeve 25 is threaded to receive the similarly threaded bore of a hub 26 to which is secured in any suitable manner a grinding wheel 27. The upper end of sleeve 25 is telescoped with a pressed fit within the lower end of a sleeve 28, the upper end of which is formed with a suitably shaped socket 29 to provide a universal joint con-

nection as at 30 with a stud 31 adapted to be received in the chuck of an ordinary electric drill.

A collar 35 is secured to the lower end of sleeve 28 as by a set screw 36 which may be extended through sleeve 28 into engagement with sleeve 25, as shown, to further assure against relative movement between the sleeves. Sleeve 28 is provided with a flange 37 between which and fixed collar 35 are rotatably mounted a pair of similar eccentric collars or disks 38 and 39 forming a two part weight member. The disks are adapted to be secured together with their perimeters in concentric relation to each other by means of a pin 40 secured in the lower disk 39 engaging in an opening 41 formed in upper disk 38, a light spring 42 positioned between flange 37 and the upper face of disk 38 normally preventing disengagement of the pin from the opening. Spring 42 normally exerts only a slight pressure on the disks and does not materially interfere with the freedom of rotation of the disks about the sleeve 28, merely assuring that they rotate together as a unit. When the disks are connected together as described they provide the radial damping force acting on the arbor of the grinding wheel for the purposes and results fully set forth in the above mentioned patent. With the construction of said patent it is necessary in dressing the stone to remove it from the driving arbor and mount it on a normally rotating shaft. One advantage of the present construction is that it renders such removal unnecessary and therefore facilitates frequent dressing of the stone which gives a freer cutting action and lengthens the useful life of the stone. By the present invention this change from the damped rotation, desired for the grinding action, to a conventional balanced rotation of the driving arbor is obtained by a simple adjustment and is accomplished by raising the upper disk against the action of spring 42 and rotating the disk 38 180° with respect to disk 39 as shown in Figs. 4 and 6. Disk 38 is provided with a second opening 44 in which pin 40 engages to again lock the disks together. When the disks are thus positioned the eccentric weight of one balances the other and the driving arbor rotates as a normal balanced shaft, the condition desired for dressing the stone. It also permits the use of the arbor for the final polishing of the finished seat where normal rotation of the arbor is also desired.

If desired, disk 38 may be provided with additional openings 45 positioned intermediate openings 41 and 44 permitting the effective weight

eccentricity of the two collars to be varied as desired.

I claim:

- 5 1. In a driving arbor for valve seat grinding wheels, a pair of disks rotatably and eccentrically mounted on the arbor, a plurality of openings formed in one of the disks, a pin carried by the other disk and adapted to be selectively engaged in said openings to compel said disks to rotate as a unit, one of said openings being so positioned
10 that when the pin is engaged therein, the eccentric weights of the disks balance each other on opposite sides of the arbor.
- 15 2. In a driving arbor for valve seat grinding wheels, a flange formed on said arbor, a collar releasably secured to the arbor adjacent the end

upon which the grinding wheel is mounted and in spaced relation to said flange, a pair of disks rotatably and eccentrically mounted on the arbor between said flange and collar, a plurality of openings formed in one of the disks, a pin carried by the other disk and adapted to be selectively engaged in said openings to compel said disks to rotate as a unit, one of said openings being so positioned that when the pin is engaged therein the eccentric weights of the disks balance each other on opposite sides of the arbor, and a spring positioned between the flange and adjacent disk to releasably maintain said pin in engagement with the selected opening.

FRANCIS P. HEALY.