



- (51) International Patent Classification:
B25B 3/00 (2006.01) *B25B 5/00* (2006.01)
- (21) International Application Number:
PCT/US2015/021659
- (22) International Filing Date:
20 March 2015 (20.03.2015)
- (25) Filing Language: English
- (26) Publication Language: English
- (30) Priority Data:
14/221,914 21 March 2014 (21.03.2014) US
- (72) Inventor; and
- (71) Applicant : **KOZAK, Burton** [US/US]; 1300 N. Lakeshore Dr., Unit 28C, Chicago, IL 60610 (US).
- (74) Agent: **FACTOR, Jody, L.**; Factor Intellectual Property Law Group, Ltd., 1327 W. Washington Blvd. Suite 5G/H, Chicago, IL 60607 (US).
- (81) Designated States (*unless otherwise indicated, for every kind of national protection available*): AE, AG, AL, AM,

AO, AT, AU, AZ, BA, BB, BG, BH, BN, BR, BW, BY, BZ, CA, CH, CL, CN, CO, CR, CU, CZ, DE, DK, DM, DO, DZ, EC, EE, EG, ES, FI, GB, GD, GE, GH, GM, GT, HN, HR, HU, ID, IL, IN, IR, IS, JP, KE, KG, KN, KP, KR, KZ, LA, LC, LK, LR, LS, LU, LY, MA, MD, ME, MG, MK, MN, MW, MX, MY, MZ, NA, NG, NI, NO, NZ, OM, PA, PE, PG, PH, PL, PT, QA, RO, RS, RU, RW, SA, SC, SD, SE, SG, SK, SL, SM, ST, SV, SY, TH, TJ, TM, TN, TR, TT, TZ, UA, UG, US, UZ, VC, VN, ZA, ZM, ZW.

(84) Designated States (*unless otherwise indicated, for every kind of regional protection available*): ARIPO (BW, GH, GM, KE, LR, LS, MW, MZ, NA, RW, SD, SL, ST, SZ, TZ, UG, ZM, ZW), Eurasian (AM, AZ, BY, KG, KZ, RU, TJ, TM), European (AL, AT, BE, BG, CH, CY, CZ, DE, DK, EE, ES, FI, FR, GB, GR, HR, HU, IE, IS, IT, LT, LU, LV, MC, MK, MT, NL, NO, PL, PT, RO, RS, SE, SI, SK, SM, TR), OAPI (BF, BJ, CF, CG, CI, CM, GA, GN, GQ, GW, KM, ML, MR, NE, SN, TD, TG).

Published:

— with international search report (Art. 21(3))

(54) Title: TOOL ACCESSORY WITH A REMOVABLE ATTACHMENT PORTION

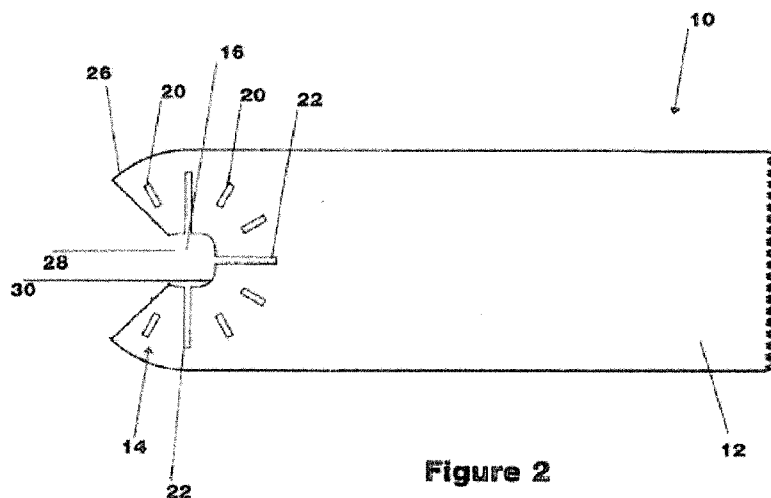

Figure 2

(57) Abstract: A tool accessory having an attachment portion having a first aperture for attaching to a tool and a removable portion, wherein in a first configuration the removable portion is engaged with the attachment portion, and in a second configuration the removable portion is disengaged from the attachment portion.

WO 2015/143265 A1

TOOL ACCESSORY WITH A REMOVABLE ATTACHMENT PORTION

Related Applications

[Para 1] None.

Field of the Invention

[Para 2] The present invention relates to tool accessories, and more specifically to tool accessories for power tools.

Background of the Invention

[Para 3] Tool accessories come in a variety of shapes and sizes in order to be utilized with a variety of tools. In order to attach to a tool which is capable of using a particular accessory, the accessory may include an attachment element. In order to attach to some tools, the attachment portion may include apertures or through holes which attach to one or more protrusions to attach the accessory. In order to securely attach the accessory to the tool, a clamp or other fastener device may be provided which holds the accessory in place once it has engaged the tool.

[Para 4] Generally speaking, for some types of tools, like for example oscillating tools, a main aperture is required to connect any accessory to the tool. However, different tools may have different accessory connection configurations. For example, some tools may require that a tool accessory have a completely enclosed or surrounded main aperture for connection. Some tools may require or be usable with an accessory which has a main aperture which is partially open. Additionally, some tools or attachment elements may have a series of protrusions for mating with a series of apertures, receptacles, or slots formed in the attachment portion of the accessory.

[Para 5] For tools which can utilize both a fully enclosed or partially open main aperture, having a partially open main aperture is advantageous insofar as it allows for the accessory to be disengaged, or re-engaged with the tool without having to completely remove any clamp or other fastener used to hold the tool accessory in place. With a partially open main aperture, the clamp or other fastener device can be partially loosened so as to disengage the tool accessory, and allow the tool accessory to loosen up and disengage the tool without having to fully remove the clamp or fastener. The clamp or fastener may be loosened up, and

the tool accessory may be slid off of the tool and disengaged through the open main aperture. This is generally faster than having to fully remove the clamp or fastener, and reduces the possibility of the clamp or fastener being lost when changing tool accessories.

[Para 6] It would be advantageous if a single tool accessory were capable of being utilized with multiple tools, regardless of the connection configuration of the tool.

[Para 7] It would be further advantageous if the single tool accessory were capable of being modified as need for use with multiple tools.

[Para 8] It would be further advantageous if the single tool accessory were capable of having a selectively enclosed or partially open main aperture for engaging the tool.

[Para 9] The present invention is directed to solving these and other problems.

Summary of the Invention

[Para 10] The present invention is directed to a tool accessory for use with tools which is capable of multiple attachment configurations, and capable of attaching to multiple tools.

[Para 11] According to one aspect of the invention, a tool accessory having an attachment portion having a first aperture for attaching to a tool, and a removable portion. In a first configuration, the removable portion is engaged with the attachment portion, and in a second configuration the removable portion is disengaged from the attachment portion.

[Para 12] The tool accessory may be an accessory intended for use with an oscillating tool. The tool accessory may further include at least one additional aperture configured to receive at least one protrusion from a tool or at least one attachment element used to connect the tool accessory to a tool. Alternatively, or in addition to the at least one aperture, the at least one tool accessory may include at least one slot configured to receive at least one protrusion from a tool or at least one attachment element used to connect the tool accessory to a tool.

[Para 13] The removable portion of the tool accessory may have a scored or perforated connection with the attachment portion. The removable portion may be disengaged from the attachment portion by mechanical means, such as bending it with a pliers or vice grips. Although a scored or perforated section has been disclosed, it will be understood by those with ordinary skill in the art that other means for providing a structurally weakened, and, in turn, breakable portion of the tool accessory can be employed to facilitate mechanical removable of the removable portion.

[Para 14] In another embodiment, the tool accessory may include at least one channel formed as part of the attachment portion. The channel may be capable of receiving, guiding,

and engaging the removable portion of the attachment portion. In order to facilitate engagement in the first configuration, the tool accessory may include at least one shoulder located at one end of the at least one channel proximate the first aperture. The at least one shoulder may engage the removable portion in the first configuration. In order to accommodate the shoulder, or the channel, and provide a uniform first aperture and surface for the tool accessory, the removable portion of the tool accessory may include at least one cutout or cutout portion. The at least one cutout portion may engage the shoulder in the first configuration when the removable portion is engaged with the attachment portion. The at least one cutout portion may further, or alternatively, extend longitudinally along an edge of the removable portion so as to fit within the channel formed in the attachment portion. Where no shoulder is located proximate the aperture, the tool accessory may include a fastener for holding the removable portion in place when in the first configuration. The fastener may be used to connect the removable portion to the attachment portion in the first configuration.

[Para 15] In yet a further embodiment, the removable portion may include at least one protrusion while the attachment portion includes at least one receptacle. The at least one protrusion formed in the removable portion may be capable of being capable of engaging or mating with the at least one receptacle in the first configuration to hold the removable portion in place while engaged. The at least one protrusion may then also being capable of disengaging the at least one receptacle to allow the removable portion to disengage the attachment portion in the second configuration.

[Para 16] These and other aspects and attributes of the present invention will be discussed with reference to the following drawings and accompanying specification and claims.

Brief Description of the Drawings

[Para 17] FIG. 1 shows a top view of a tool accessory in the first configuration as contemplated by the invention;

[Para 18] FIG. 2 shows a top view of a tool accessory in the second configuration as contemplated by the invention;

[Para 19] FIG. 3 shows a top view of a tool accessory transforming from the first configuration to the second configuration as contemplated by the invention;

[Para 20] FIG. 4 shows a back view of a tool accessory transforming from the first configuration to the second configuration as contemplated by the invention;

[Para 21] FIG. 5 shows a side view of a tool accessory transforming from the first configuration to the second configuration as contemplated by the invention;

[Para 22] FIG. 6 shows a top view of a tool accessory in the first configuration as contemplated by the invention;

[Para 23] FIG. 7 shows a top view of a tool accessory in the second configuration as contemplated by the invention;

[Para 24] FIG. 8 shows a back view of a tool accessory in the second configuration as contemplated by the invention;

[Para 25] FIG. 9 shows a side view of a removable portion of a tool assembly in the second configuration as contemplated by the invention;

[Para 26] FIG. 10 shows a top view of a tool accessory in the first configuration as contemplated by the invention;

[Para 27] FIG. 11 shows a top view of a tool accessory in the second configuration as contemplated by the invention;

[Para 28] FIG. 12 shows a back view of a tool accessory in the second configuration as contemplated by the invention;

[Para 29] FIG. 13 shows a close up of portion A in FIG. 11;

[Para 30] FIG. 14 shows a top view of a tool accessory in the first configuration as contemplated by the invention;

[Para 31] FIG. 15 shows a top view of a tool accessory in the second configuration as contemplated by the invention;

[Para 32] FIG. 16 shows a back view of a removable portion of a tool accessory in the second configuration as contemplated by the invention;

[Para 33] FIG. 17 shows a side view of a removable portion of a tool assembly in the second configuration as contemplated by the invention;

[Para 34] FIG. 18 shows a back view of tool accessory in the second configuration; and

[Para 35] FIG. 19 shows a view of portion B from FIG. 15.

Detailed Description of the Present Invention

[Para 36] While the present invention is susceptible of embodiment in many different forms, there is shown in the drawings and will herein be described in detail several preferred embodiments of the invention with the understanding that the present disclosure is to be considered as an exemplification of the principles of the invention and is not intended to limit the broad aspect of the invention to the embodiments illustrated.

[Para 37] FIG. 1 shows a top view of an embodiment of a tool accessory as contemplated by the present invention. Tool accessory 10 including a working portion or end 12 and an attachment portion or end 14. The attachment portion includes a first or main aperture 16 and a removable portion 18. The first or main aperture may be utilized to attach the tool accessory to a tool, which may be, for example, an oscillating tool. The first or main aperture, may, for example, engage or be received on a spindle or shaft on an oscillating tool in order for the tool accessory to be used.

[Para 38] The tool accessory may further include at least one additional aperture 20 and at least one slot 22. Though shown throughout the application as including both additional apertures and slots, tool accessory 10 may include only additional apertures, only slots, both additional apertures and slots, or neither apertures nor slots. Including both apertures and slots, however, may allow the tool accessory to attach to multiple tools which have different engagement or attachment configurations. Any additional apertures or slots may be engaged by one or more of the tool and any attachment element associated with the tool which fixes the tool accessory in place once the tool accessory is engaged with the tool. An attachment element may be, for example, a clamp, a fastener, a disc, or some other element capable of being fixed to the tool in a manner which engages both the tool and tool accessory and fixes the tool accessory in place for use by the tool.

[Para 39] FIG. 1 shows tool accessory 10 in a first configuration where removable portion 18 is engaged with attachment portion or end 14 of the tool accessory. Removable portion 18 may be engaged with attachment portion or end 14 utilizing a scored or perforated (or any other connection that enables mechanical removal, by, for example, a pliers or other bending method) connection 24 which may allow for the removable portion to be lifted/bent and removed or disengaged from the attachment portion. Once the removable portion is removed, tool accessory 10 will be in a second configuration whereby first or main aperture 16 is partially open along the back of the tool accessory to allow for a different connection or engagement configuration for the tool accessory. FIG. 2 shows a top view of tool accessory 10 in the second configuration.

[Para 40] FIGs. 3-5 show various views of a partially removed removable portion 18 in the tool accessory embodiment shown in FIGs. 1 and 2. FIG. 3, which is a top view, shows removable portion 18 being bent upwards, after one side of removable portion 18 has been disengaged from attachment portion or end 14. FIG. 4, which is a back view of tool accessory 10, and FIG. 5, which is a side view of tool accessory 10, further show the disengagement of a portion of removable portion 18 from attachment portion 14. As seen in

FIGs. 3-5, after appropriate bending, removable portion 18 will completely breakaway from the tool accessory so that first or main aperture 16 is opened along back edge 26 of the tool accessory to eventually provide channel 28 – which can also be seen in FIG. 2. Interior portion 30 of first or main aperture 16 will remain intact for engaging a tool, as needed.

[Para 41] Scored or perforated connection 24 may take any form, so long as a large enough channel is created to allow tool accessory 10 to engage and disengage from a tool through channel 28. It may, as seen in FIGs. 1-5 include an angled portion 32 and a straight portion 34, however the entire connection 24 may be angled, straight, curvilinear, or any other shape which will allow for the removal of the removable portion. In order to realize the full effect of channel 28 and the opened first or main aperture, when the first or main aperture is round, for example, the channel should provide an opening at least wide enough for the connection element of a tool to fit through the channel and engage the first or main aperture.

[Para 42] Removable portion 18 may be removed or disengaged from attachment portion 14 using any means which will effectively breakaway the removable portion along scored or perforated connection 24. For example, pliers or vice grips may be utilized to grip the removable portion and twist or break it away from the attachment portion to disengage it. Alternatively, the removable portion may be punched or knocked out using a hammer or similar element.

[Para 43] By providing removable portion 18 and any additional apertures 20 or slots 22, tool accessory 10 can be configured to connect to multiple tools having different connection configurations. The tool accessory may also be capable of realizing the advantage of having an open first or main aperture to engage and disengage the tool without having to fully remove any clamps, fasteners, or other connection elements. For tools which require a fully enclosed first or main aperture, tool accessory 10 can be left in the first configuration as shown in FIG. 1. Where a tool requires a partially open first or main aperture, tool accessory can be altered to the second configuration as shown in FIG. 2. Where the tool accessory is to be used with a tool which can use either an opened or enclosed first or main aperture, the removable portion may be left in for potential future use with a tool which requires a fully enclosed first or main aperture, or the removable portion may be disengaged from the attachment portion to allow for the easier connect/disconnect of the tool accessory from the tool.

[Para 44] While the embodiment of the tool accessory shown in FIGs. 1-5 are capable of use with multiple tools having different configurations, once the tool accessory is in the second configuration, putting the tool accessory back into the first configuration is generally

not possible or requires great effort. In other embodiments, however, the tool accessory may be selectively put in both the first and second configuration as needed.

[Para 45] FIG. 6 shows a second embodiment for a tool accessory in the first configuration. As seen in FIG. 6, tool accessory 110, may include working end 112, attachment portion or end 114, first or main aperture 116, removable portion 118, and additional apertures 120 or slots 122, and a fixed interior portion 130 of the first or main aperture like the embodiment shown in FIGs. 1-5. However rather than being disengageable using scored or perforated connection, a combination of a channel, shoulder, and protrusion may be utilized to allow removable portion 118 to be engaged and in the first configuration and disengaged in the second configuration so as to open channel 128 as needed. Such a configuration will allow for the re-engagement of the removable portion after it has been disengaged so that the tool accessory is capable of repeated use with a broader number of tools.

[Para 46] As seen in FIGs. 7 and 9, which show the tool accessory in the second configuration and a side view of removable portion 118, removable portion 118 may include protrusions 136 which extend along the outside of the portion of the removable edge which engages the attachment portion or end of the tool accessory. Protrusions 136 may effectively extend from back edge 138 of removable portion 118, along the outside of angled portion 140, and along a portion of straight portion 142, before ending at cutout 144. Exterior portion 146 of first or main aperture 116 will form the surface of the removable portion opposite back edge 138.

[Para 47] In the first configuration, protrusions 136 may be received in, guided and engaged by channels 148 which are formed in attachment portion 114 of tool accessory 110. The channels can be more easily seen in FIG. 8 which is a back view of the attachment portion in the second configuration. As seen in FIG. 10, channels 148 may extend along angular portion 150, into straight portion 152 (blocked from view in FIG. 8), ending at shoulder 154. When removable portion 118 is slid fully into engagement with attachment portion 114 in the first configuration, cutout 144 and shoulder 154 may prevent removable portion 118 from over sliding/extending into first or main aperture 116. The cutout and shoulder engagement will insure a uniform first or main aperture as exterior portion 146 will align with interior portion 130 to form aperture 116 in the first configuration.

[Para 48] Using the protrusion and channel configuration will allow removable portion 118 to be disengaged and then re-engaged with attachment portion 114 as necessary to accommodate different tool attachment configurations, or allow tool accessory 110 to take

advantage of channel 128 to more easily engage and disengage from a tool capable of using either an enclosed or partially open first or main aperture.

[Para 49] Though an angled and straight portion of both the channel and removable portion is discussed with respect to the embodiment shown in FIGs. 6-9, it should be understood that once again, like the embodiments shown in FIGs. 1-5, the engagement portions or connection lines may take any form which will allow the removable portion to slidingly disengage and reengage from and/or into the attachment portion.

[Para 50] While shown in the various embodiments throughout this application as a uniform surface, it should be understood that any tool accessory discussed herein may include any number of contours, bends, or configurations required or desired for the accessory. For example, the attachment portion or end may be formed on a first plane or at a first level, with the working end being connected by a ramped or sloped surface and formed on a second plane or second level above or below the attachment portion. Additionally, the working end may be made of or have a different thickness than the attachment end. For example, in embodiments utilizing channels and protrusions to engage and disengage the removable portion from the attachment portion, the attachment portion may have a greater thickness to accommodate the channels and protrusions engagement than is desired at the working portion.

[Para 51] It is also contemplated by the invention that embodiments which use channels and protrusions may not have any shoulder or cutouts to prevent the removable portion from over engaging the attachment end and extend into the first or main aperture. In order to prevent such, the shape of the angled and straight portion, or any other shape which may be used, may be altered so as to prevent over insertion or engagement of the removable portion.

[Para 52] In some embodiments, however, like those shown in FIGs. 10-13, a connector or fastener may be used to hold the removable portion in engagement with the attachment portion.

[Para 53] FIG. 10 shows an embodiment of tool accessory 210 in the first configuration. As with the embodiments shown in FIGs. 1-5 and 6-9, tool accessory 210, may include working end 212, attachment portion or end 214, first or main aperture 216, removable portion 218, and additional apertures 220 or slots 222, and a fixed interior portion 230 of the first or main aperture. In addition to those elements, in the first configuration, fasteners 256 may be utilized to hold removable portion 218 in place and keep it engaged with attachment element 214. In order to present a flush face, attachment element 214 may include receptacles 258 or the like which can receive any fastener head when the fastener is engaged with the attachment and removable portions.

[Para 54] In order to accommodate and receive the fastener portions, channels 248 may include transverse receiving channels 260 which will allow fasteners 256 to pass through channel 248. The transverse receiving channels can be seen in FIG. 12 which is a back view of the attachment element in the second configuration. The fasteners may pass through the receiving channels and engage a corresponding fastener aperture 262 formed in protrusion 236 of the removable portion which can be seen in FIG. 13 – which is a close-up of portion A in FIG. 11, showing an edge of the removable portion in the second configuration. Fasteners 256 can be dropped down through receiving channels 260 and into fastener apertures 262 to hold removable portion 218 in place and keep it engaged in the first configuration. The remainder of the embodiment shown in FIGs. 10-13 may be kept substantially the same as the embodiment shown in FIGs. 6-9 with regards to the channels and protrusion and the respective engagement and disengagement of both.

[Para 55] The fastener used may be any fastener known in the art which may be fastened and unfastened once or multiple times. For example, a pin or a screw may be used. Where a threaded element like, for example a screw, is used, the interior of the transverse receiving channels and the interior of any fastener apertures may have a mating thread configuration to allow for better engagement.

[Para 56] An additional embodiment of a tool accessory can be seen in FIGs. 14-19. Tool accessory 310 includes working end 312, attachment portion or end 314, first or main aperture 316, removable portion 318, and additional apertures 320 or slots 322, and a fixed interior portion 330 of the first or main aperture. Rather than have any channels and/or separate fasteners, the removable portion may include a lip having at least one protrusion, and the attachment portion may include a seat having at least one mating receptacle. The removable portion may then be placed to sit on the seat of the attachment portion when engaged in the first configuration, and the mating protrusions and receptacles may engage to prevent the removable portion from disengaging.

[Para 57] The shoulder formed in the attachment portion can be seen, for example, in FIGs. 15, 18, and 19. As seen in FIGs. 15 and 19, which show a top view of the tool accessory in the second configuration and a close up of portion B of FIG. 15 respectively, seat 364 may extend along the entire engagement edge of the attachment portion, like for example along angled portion 350 and straight portion 352. The shoulder may include receptacles 366 which will receive the protrusions from removable portion 318 when the removable portion is engaged in the first configuration. The receptacles may be a ridge, divot

or channel formed in the surface of the seat, or alternatively may be through holes through which a longitudinal protrusion may extend and engage.

[Para 58] The protrusions can be seen in FIGs. 16 and 17 which are back and side views of removable portion 318 respectively. As seen in FIGs. 16 and 17, protrusions 368 extend downwards from lip 370 which will overlap and engage seat 364. The protrusions may be any shape or configuration, like for example nubs or pins.

[Para 59] It is to be understood that additional embodiments of the present invention described herein may be contemplated by one of ordinary skill in the art and the scope of the present invention is not limited to the embodiments disclosed. While specific embodiments of the present invention have been illustrated and described, numerous modifications come to mind without significantly departing from the spirit of the invention, and the scope of protection is only limited by the scope of the accompanying claims.

CLAIMS

What is claimed is:

1. A tool accessory comprising:
an attachment portion having a first aperture for attaching to a tool and a removable portion, wherein
in a first configuration the removable portion is engaged with the attachment portion, and
in a second configuration the removable portion is disengaged from the attachment portion.
2. The tool accessory of claim 1 being used with an oscillating tool.
3. The tool accessory of claim 2 further comprising at least one additional aperture, the at least one additional aperture being configured to receive at least one protrusion from a tool or at least one attachment element used to connect the tool accessory to a tool.
4. The tool accessory of claim 3 further comprising at least one slot, the at least one slot being configured to receive at least one protrusion from a tool or at least one attachment element used to connect the tool accessory to a tool.
5. The tool accessory of claim 3 further comprising at least one slot, the at least one slot being configured to receive at least one protrusion from a tool or at least one attachment element used to connect the tool accessory to a tool.
6. The tool accessory of any one of claims 1-5 wherein the removable portion has a scored or perforated connection with the attachment portion, the removable portion being capable of becoming disengaged from the attachment portion at the scored or perforated connection.
7. The tool accessory of any one of claims 1-6 further comprising at least one channel, the at least one channel formed as part of the attachment portion and being capable of receiving, guiding, and engaging the removable portion of the attachment portion.

8. The tool accessory of claim 7 further comprising at least one shoulder, the at least one shoulder being located at one end of the at least one channel proximate the first aperture, the at least one shoulder engaging the removable portion in the first configuration when the removable portion is engaged with the attachment portion.
9. The tool accessory of claim 8 wherein the removable portion includes at least one cutout, the at least one cutout engaging the shoulder in the first configuration when the removable portion is engaged with the attachment portion.
10. The tool accessory of claim 7 further comprising a fastener, the fastener being used to connect the removable portion to the attachment portion in the first configuration.
11. The tool accessory of any one of claims 1-10 wherein the removable portion includes at least one protrusion and the attachment portion includes at least one receptacle, the at least one protrusion being capable of engaging the at least one receptacle in the first configuration while being capable of disengaging the at least one receptacle in the second configuration.
12. The tool accessory of any one of claims 1-11 wherein the removable portion is capable of being selectively engaged, disengaged, and re-engaged with the attachment portion.
13. A tool accessory as shown and described herein.

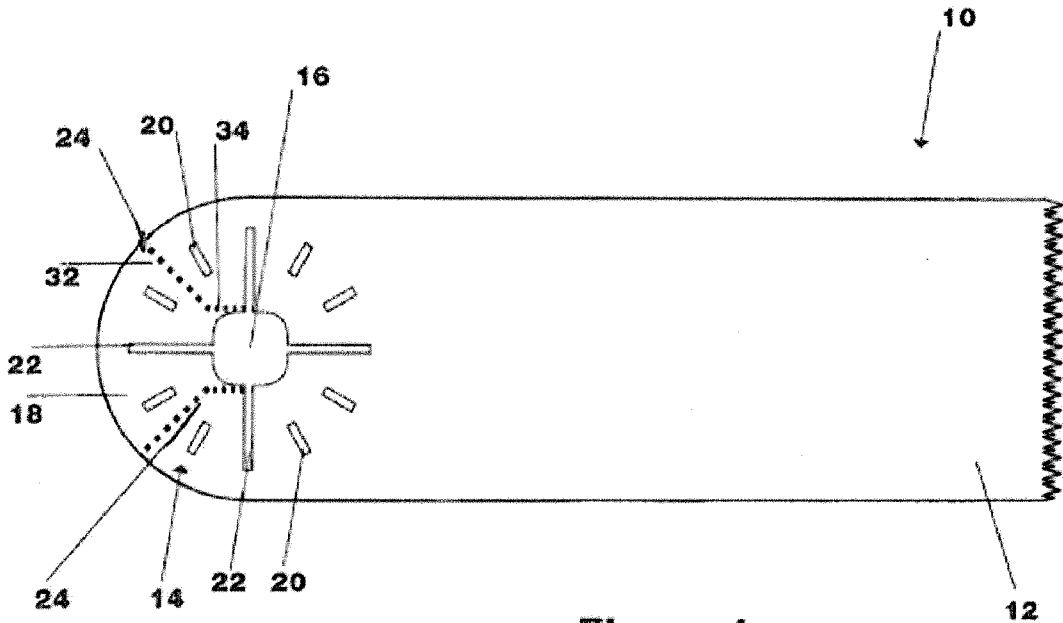

Figure 1

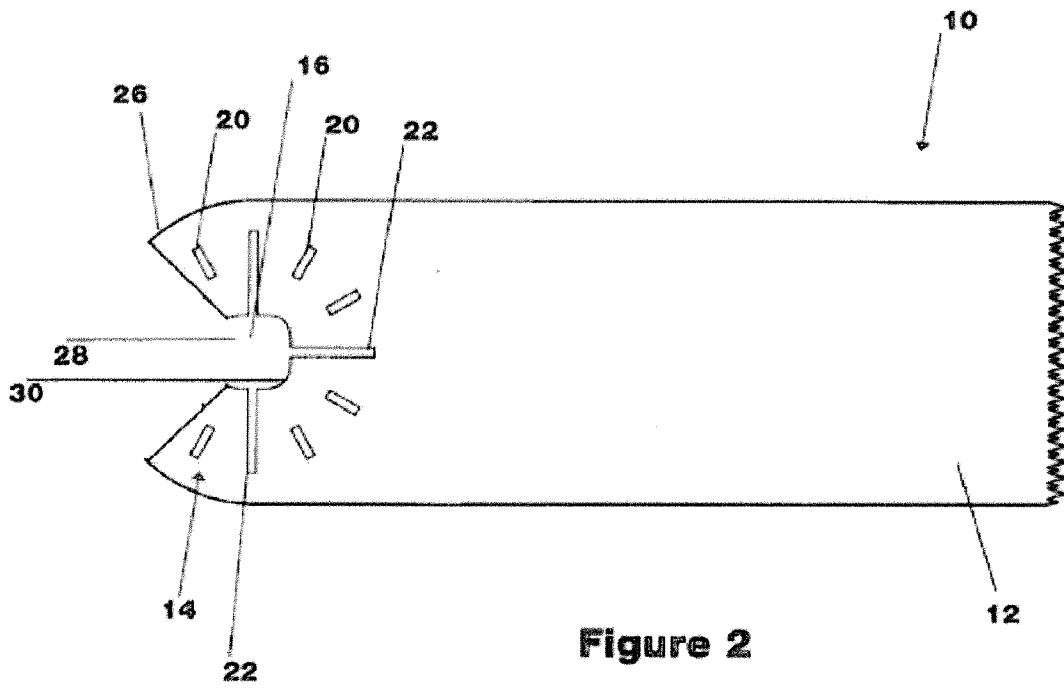

Figure 2

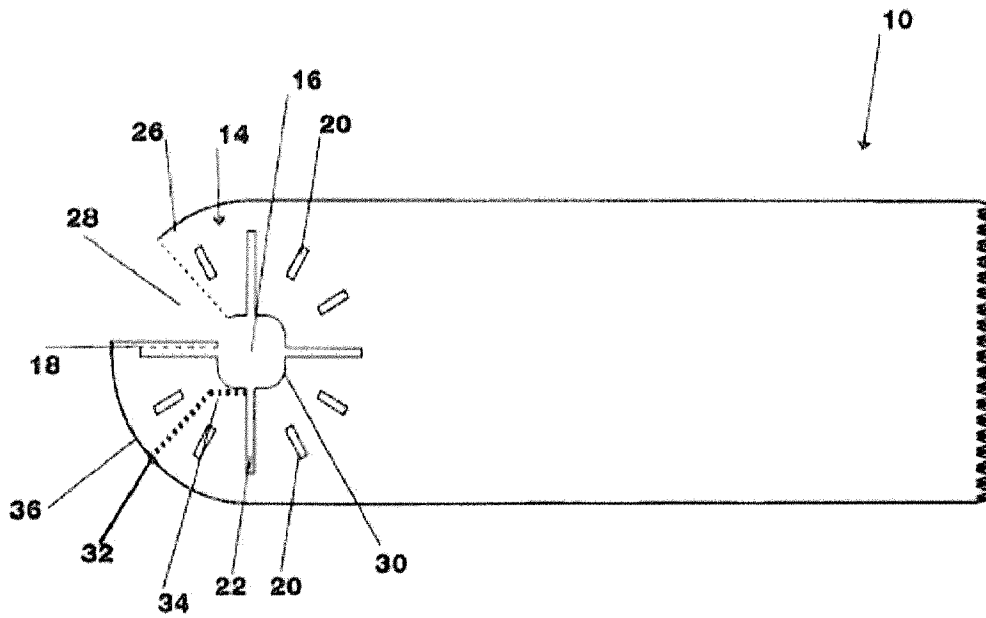

Figure 3

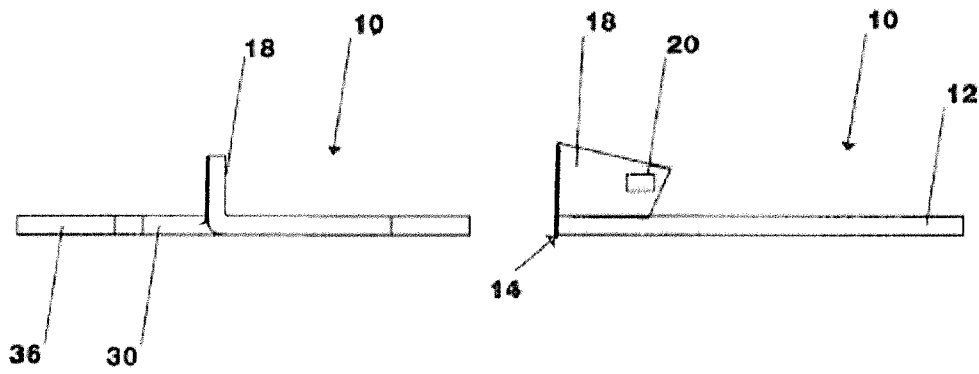
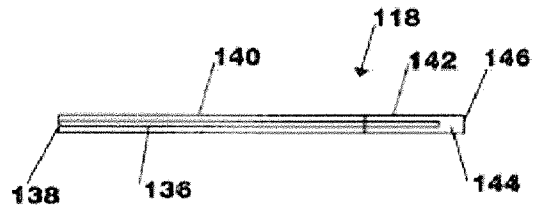
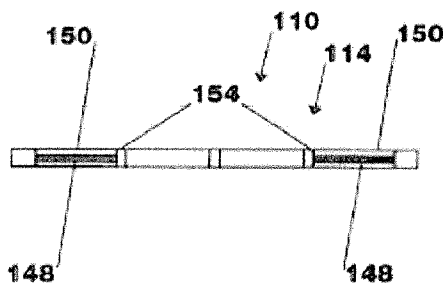
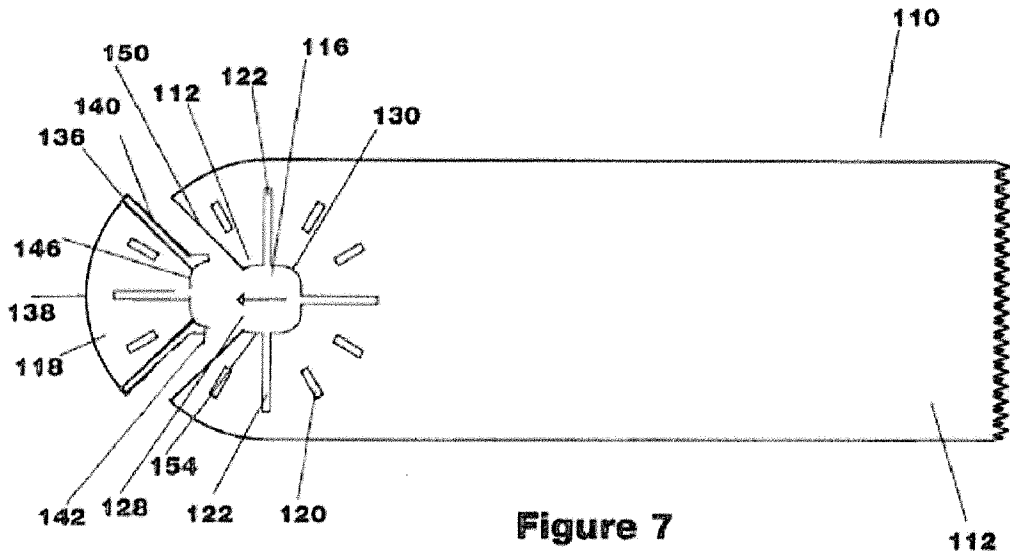
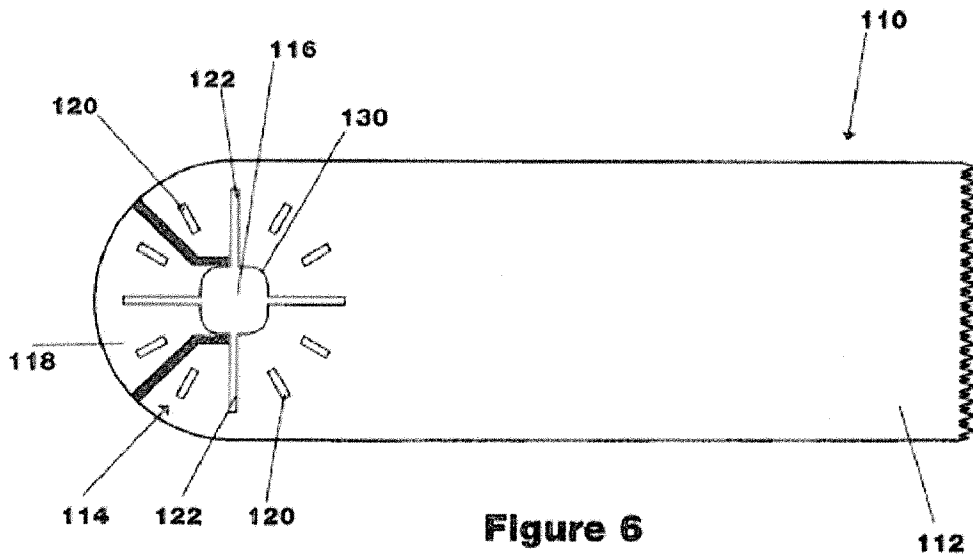

Figure 4

Figure 5



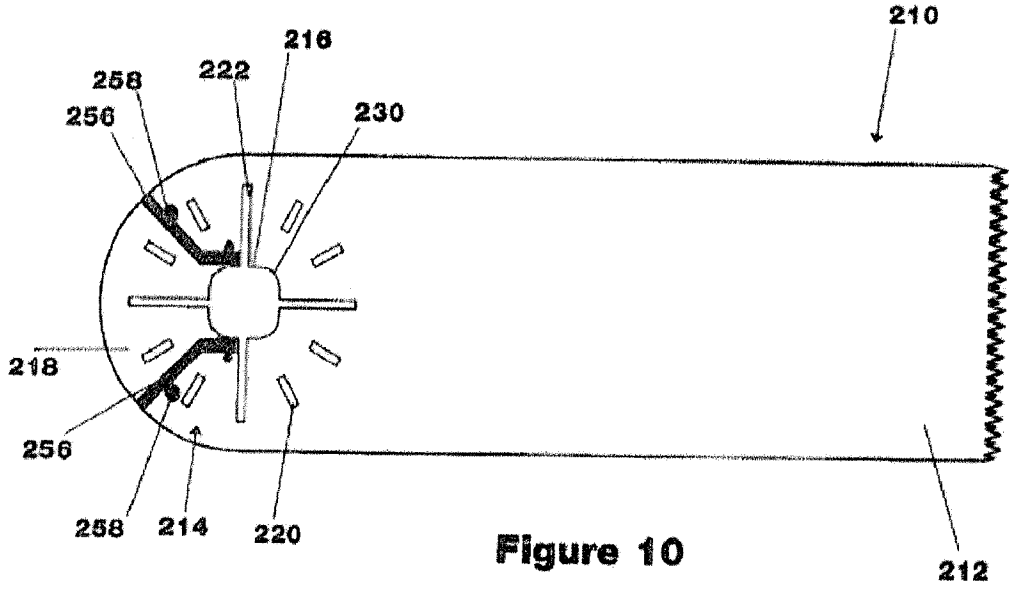

Figure 10

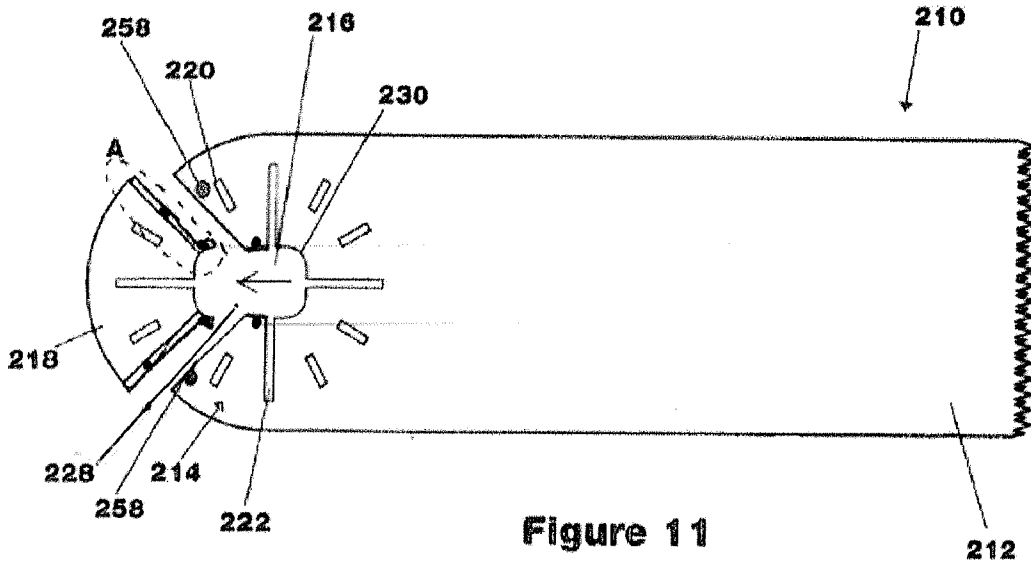

Figure 11

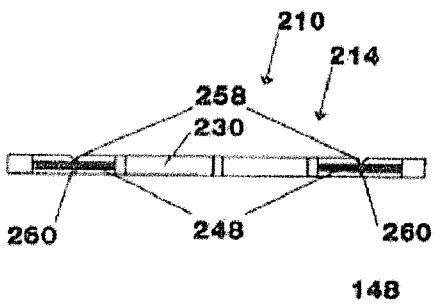

Figure 12

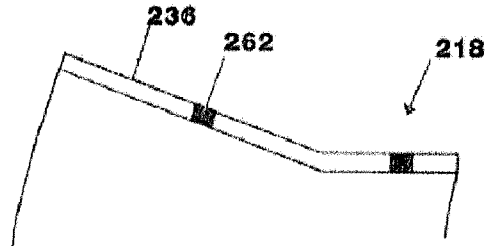

Figure 13

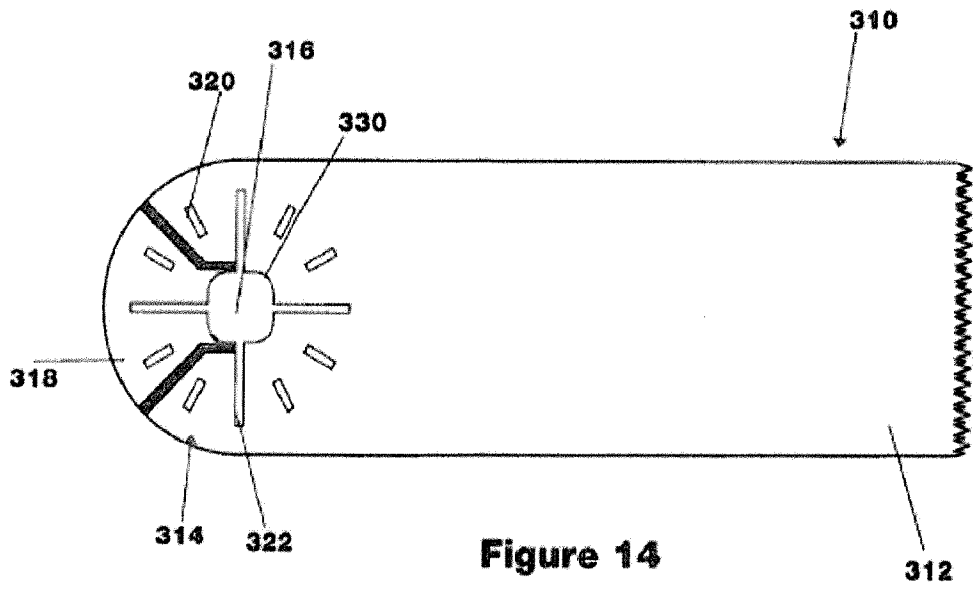

Figure 14

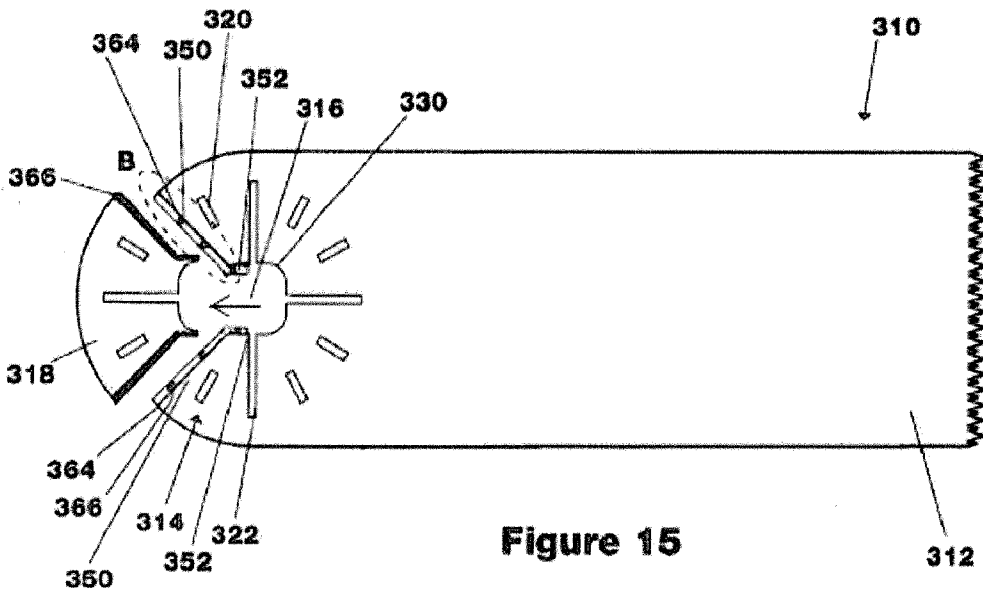

Figure 15

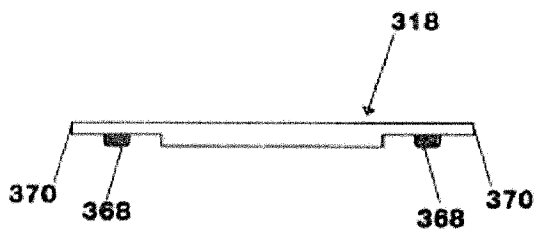

Figure 16

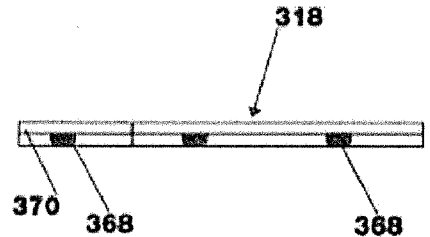
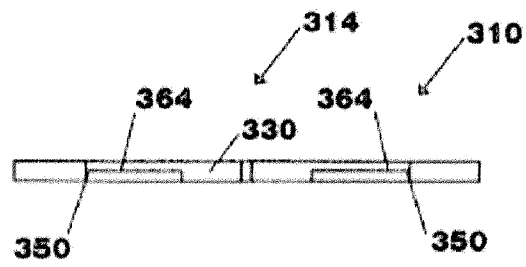
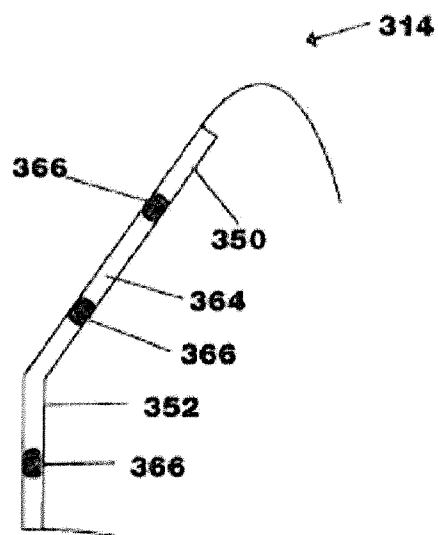

Figure 17

**Figure 18****Figure 19**

INTERNATIONAL SEARCH REPORT

International application No.

PCT/US15/21659

A. CLASSIFICATION OF SUBJECT MATTER

IPC(8) - B25B 3/00, 5/00 (2015.01)

CPC - B24B 45/003, 45/006; B27B 19/006

According to International Patent Classification (IPC) or to both national classification and IPC

B. FIELDS SEARCHED

Minimum documentation searched (classification system followed by classification symbols)

IPC(8) Classification(s): B25B 3/00, 5/00 (2015.01)

CPC Classification(s): B24B 45/00, 45/003, 45/006; B27B 19/006

Documentation searched other than minimum documentation to the extent that such documents are included in the fields searched

Electronic data base consulted during the international search (name of data base and, where practicable, search terms used)

PatSeer (US, EP, WO, JP, DE, GB, CN, FR, KR, ES, AU, IN, CA, INPADOC Data): rotary, rotating, oscillating, power tool, accessory, attachment, fitting, removable, closure, clamp, hole, aperture, projection, protrusion, adapter, two piece, score, perforated, weakened, zig zag, puzzle, friction

C. DOCUMENTS CONSIDERED TO BE RELEVANT

Category*	Citation of document, with indication, where appropriate, of the relevant passages	Relevant to claim No.
X	AU 2013/205490 A1 (BLACK & DECKER) May 16, 2013; figures 1, 16-17; paragraphs [0043], [0058]	1-5, 13
X	US 2014/0033880 A1 (HILL T.) February 6, 2014; figures 6-7; paragraph [0038]	1
A	US 2014/0035242 A1 (KAYE T. R. JR. et al.) February 6, 2014; figures 5A, 5D; paragraphs [0017], [0024]	1-5, 6/1-6/5, 13
A	WO 2013/077862 A1 (ROBERT BOSCH GMBH) May 30, 2013; entire document	1-5, 6/1-6/5, 13

 Further documents are listed in the continuation of Box C. See patent family annex.

* Special categories of cited documents:

"A" document defining the general state of the art which is not considered to be of particular relevance

"E" earlier application or patent but published on or after the international filing date

"L" document which may throw doubts on priority claim(s) or which is cited to establish the publication date of another citation or other special reason (as specified)

"O" document referring to an oral disclosure, use, exhibition or other means

"P" document published prior to the international filing date but later than the priority date claimed

"T" later document published after the international filing date or priority date and not in conflict with the application but cited to understand the principle or theory underlying the invention

"X" document of particular relevance; the claimed invention cannot be considered novel or cannot be considered to involve an inventive step when the document is taken alone

"Y" document of particular relevance; the claimed invention cannot be considered to involve an inventive step when the document is combined with one or more other such documents, such combination being obvious to a person skilled in the art

"&" document member of the same patent family

Date of the actual completion of the international search

22 May 2015 (22.05.2015)

Date of mailing of the international search report

08 JUL 2015

Name and mailing address of the ISA/

Mail Stop PCT, Attn: ISA/US, Commissioner for Patents

P.O. Box 1450, Alexandria, Virginia 22313-1450

Facsimile No. 571-273-8300

Authorized officer

Shane Thomas

PCT Helpdesk: 571-272-4300
PCT OSP: 571-272-7774

INTERNATIONAL SEARCH REPORT

International application No.

PCT/US15/21659

Box No. II Observations where certain claims were found unsearchable (Continuation of item 2 of first sheet)

This international search report has not been established in respect of certain claims under Article 17(2)(a) for the following reasons:

1. Claims Nos.:
because they relate to subject matter not required to be searched by this Authority, namely:

2. Claims Nos.:
because they relate to parts of the international application that do not comply with the prescribed requirements to such an extent that no meaningful international search can be carried out, specifically:

3. Claims Nos.: 7-12
because they are dependent claims and are not drafted in accordance with the second and third sentences of Rule 6.4(a).

Box No. III Observations where unity of invention is lacking (Continuation of item 3 of first sheet)

This International Searching Authority found multiple inventions in this international application, as follows:

1. As all required additional search fees were timely paid by the applicant, this international search report covers all searchable claims.
2. As all searchable claims could be searched without effort justifying additional fees, this Authority did not invite payment of additional fees.
3. As only some of the required additional search fees were timely paid by the applicant, this international search report covers only those claims for which fees were paid, specifically claims Nos.:

4. No required additional search fees were timely paid by the applicant. Consequently, this international search report is restricted to the invention first mentioned in the claims; it is covered by claims Nos.:

- Remark on Protest**
- The additional search fees were accompanied by the applicant's protest and, where applicable, the payment of a protest fee.
- The additional search fees were accompanied by the applicant's protest but the applicable protest fee was not paid within the time limit specified in the invitation.
- No protest accompanied the payment of additional search fees.