

No. 748,723.

PATENTED JAN. 5, 1904.

C. J. HAMILTON.
FIREARM.

APPLICATION FILED MAY 13, 1901.

NO MODEL.

4 SHEETS—SHEET 1.

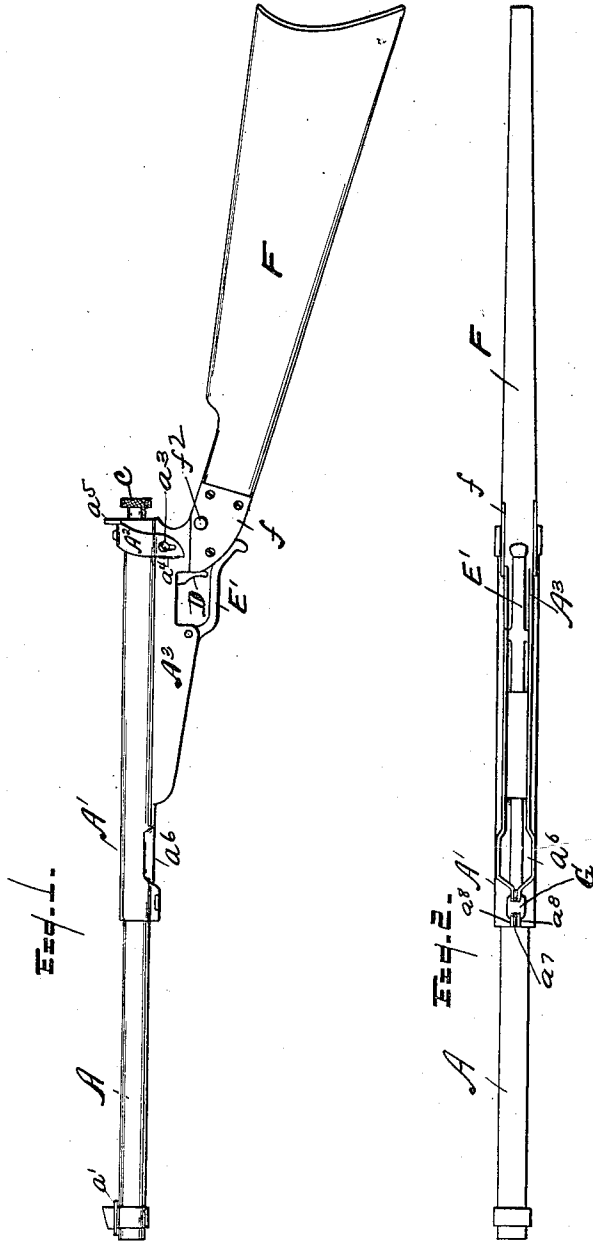

WITNESSES
Lottie MacLeod.
Frank A. Duval.

INVENTOR
Clarence J. Hamilton
By J. H. Thomas
Attorneys

No. 748,723.

PATENTED JAN. 5, 1904.

C. J. HAMILTON.
FIREARM.

APPLICATION FILED MAY 13, 1901.

NO MODEL.

4 SHEETS—SHEET 2.

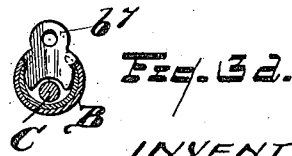
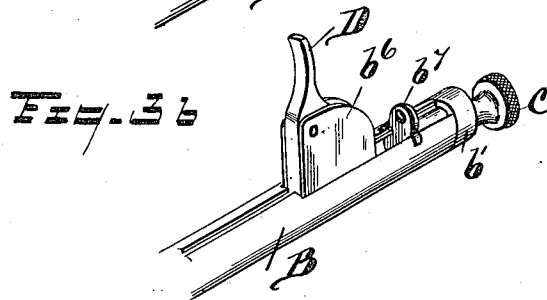
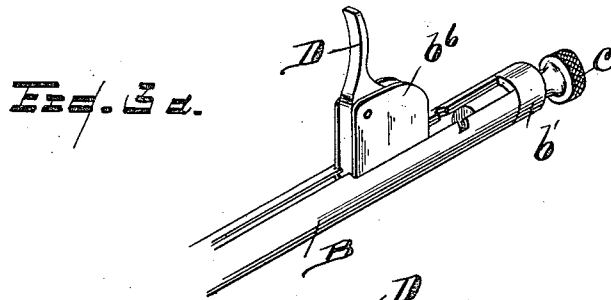
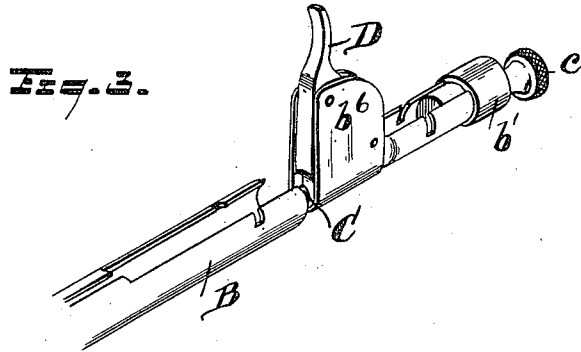

WITNESSES

Lee Aubrey.
Henry E. Villert.

INVENTOR

Clarence J. Hamilton
By Fink & Thomas
Attorneys

No. 748,723

PATENTED JAN. 5, 1904.

C. J. HAMILTON.
FIREARM.

APPLICATION FILED MAY 13, 1901.

NO MODEL.

4 SHEETS—SHEET 3.

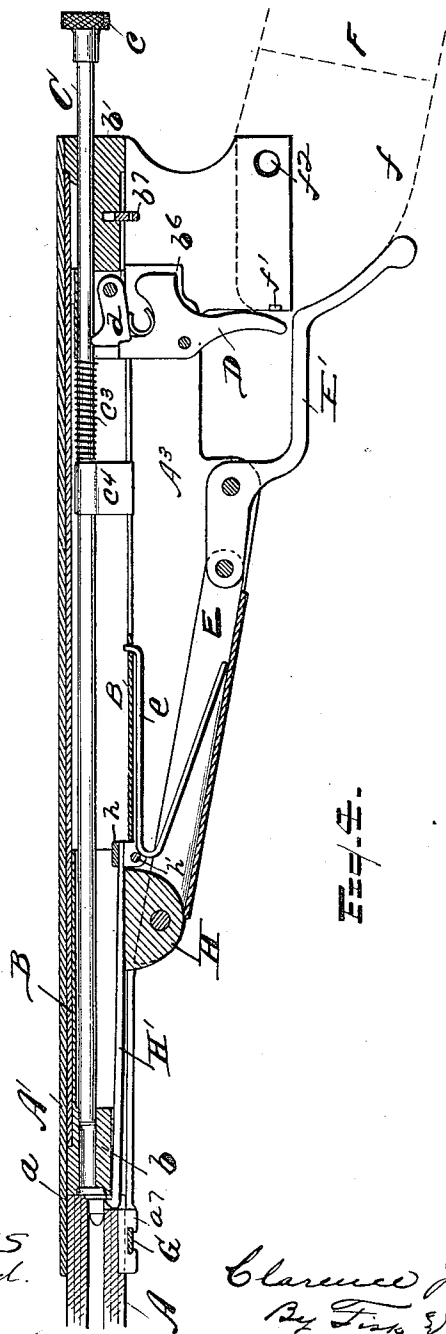

WITNESSES
 Lottie Mae Lead.
 Frank D. Snow.

INVENTOR
 Clarence J. Hamilton
 By Fish & Thomas
 Attorneys

UNITED STATES PATENT OFFICE.

CLARENCE J. HAMILTON, OF PLYMOUTH, MICHIGAN, ASSIGNOR, BY MESNE ASSIGNMENTS, TO COELLO HAMILTON, OF PLYMOUTH, MICHIGAN.

FIREARM.

SPECIFICATION forming part of Letters Patent No. 748,723, dated January 5, 1904.

Application filed May 13, 1901. Serial No. 59,997. (No model.)

To all whom it may concern:

Be it known that I, CLARENCE J. HAMILTON, a citizen of the United States, residing at Plymouth, county of Wayne, State of Michigan, have invented a certain new and useful Improvement in Rifles; and I hereby declare the following to be a full, clear, and exact description of the invention, such as will enable others skilled in the art to which it pertains to make and use the same, reference being had to the accompanying drawings, which form a part of this specification.

My invention relates to improvements in firearms; and it consists in improvements in the details of construction of small rifles and is shown in the accompanying drawings, in which—

Figure 1 is a side elevation. Fig. 2 is an inverted plan view. Fig. 3 is a perspective view showing the trigger-case disengaged from the reciprocating tube. Fig. 3^a shows the trigger mechanism housed within the reciprocating tube and indicating the relative position of the parts before they are secured by the locking-key. Fig. 3^b is a similar view showing the parts locked by the insertion of the key. Fig. 3^c is a view of the locking-key. Fig. 3^d is a cross-sectional view through the reciprocating tube and the tube to which the trigger-case is secured, showing the locking-key in position. Fig. 4 is a longitudinal vertical sectional view in which the parts are shown in position for firing. Fig. 5 is a longitudinal vertical sectional view in which the parts are in position for loading.

This invention consists in an improvement in the general construction of rifles, but relates more particularly to an improvement in the receiver in which the rifle is secured, the object being to construct the receiver of sheet metal having depending plates at the rear to engage the stock; also, in the reciprocating breech-block mechanism adapted to travel within the receiver and carrying the firing-pin, trigger-case, and mechanism; also, in the form of extractor employed; also, in the trigger-case and connection with the firing-pin, and in other details of construction, as may hereinafter appear, the object being to simplify and cheapen the construction of rifles as heretofore made.

In the drawings, A is the rifle-barrel, which terminates at *a*, where the breech end of the rifle-barrel is set into the receiver A'. This rifle-barrel I build up of a series of tubes, one around another, until the proper amount of strength is secured. At the forward end of the barrel I provide a front sight, which consists of a sleeve surrounding the barrel, the free ends of the material of which the sleeve is formed being turned upward and united in a slot in a reinforcing-piece. The free ends extending above the reinforcing-piece constitute the front sight. By this form of construction I provide a sleeve around the forward end of the barrel and a very simple and inexpensive way of fastening the free ends of the sleeve together in the reinforcing-piece. The parts after they are assembled may be brazed or soldered.

A² is a rear sight secured to the bracket A³ by the set-screw *a*³. The sight is held in a fixed position by the slot *a*⁴, formed in the bracket.

*a*⁵ is a peep-sight secured to the upper end of the part A² by a set-screw.

The receiver A' is formed integral with the bracket A³, being formed of sheet metal in a press. The under side of this receiver is open, as shown in Fig. 2, the opening being enlarged at *a*⁶ to provide sufficient space in which to enter a cartridge into the rear of the rifle-barrel A. Thus the rifle is loaded from the under side through this opening in the receiver, and the cartridges after they have been fired are discharged through its opening.

B is a reciprocating inner tube fitting snugly in the receiver and extending from one end to the other. This inner tube is provided at the forward end with a plug *b*, which forms the breech-block of the rifle, and it is provided at the rear end with a plug *b*['], which forms a block against which the firing-pin C strikes at the limit of its forward movement. This firing-pin C is mounted to reciprocate inside of the tube B and independent of it when the firing-pin is reciprocating for firing the cartridge, and when the tube B is drawn back to draw the breech-block away from the breech end of the barrel it carries with it the firing-pin. The forward end of the firing-pin is provided with the usual projection to

fire the cartridge and at the rear end with the thumb-piece *c*, which serves as a means by which the pin can be drawn back for setting it in position for firing and as a stop to limit its forward movement.

*c*⁴ is a collar fixed to the firing-pin, and *c*³ is a spring interposed between this collar *c*⁴ and the trigger-case *b*⁶, fixed in the tube, whereby the spring is caused to force the firing-pin to the forward limit of its movement. This trigger-case *b*⁶ is a U-shaped part, preferably engaged with the plug *b*⁷ and so arranged that by removing the key *b*⁷ the plug and trigger-case, with the trigger, can be removed from the sleeve B. It will be seen that when the trigger-case secured to the plug *b*⁷ is inserted within the reciprocating tube B, as shown in Fig. 3^a, the notches cut into the tubes to receive the locking-key will register with each other. It is then only necessary to force the key *b*⁷ into position, as shown in Fig. 3^b, to secure the trigger mechanism within the reciprocating tube, the whole traveling together when operated by the lever E', as shown in Fig. 5. Within the trigger-case are mounted the trigger D and the sear *d*, which latter is provided with an upwardly-extending point that enters a notch or hole in the under side of the firing-pin when the firing-pin is drawn rearwardly into its position ready for firing. This trigger mechanism is similar to that shown in prior patents of mine and need not be further described.

E is a link pivoted at the forward end to a depending ear H on the tube B and is pivoted at the rear end to the lever E', forming the trigger-guard. This lever E' is so formed that when it is thrown forward it draws the link E and the tube B, with of all its connecting parts, including the firing-pin and the trigger mechanism, rearwardly, drawing the forward end of the tube B or breech-block away from the breech end of the rifle-barrel a sufficient distance to permit a cartridge to be entered in the barrel. When the lever E' is thrown forward to its limit, the rear end of the link passes a sufficient distance to the rear to lock it and prevent its being thrown outwardly by a spring *e*, that is interposed between the link and the tube B. The rear end of this link E when the lever E' is thrown to its rearward limit is in such a position that the link is locked and the tube B and breech-block carried by it locked against the breech end of the rifle and the cartridge.

F is the stock of the gun and is provided at its forward end with stock-plates *f*, and these plates are provided with an inset lug *f*¹, which engage recesses in the edge of the bracket facing the trigger-opening. The stock is engaged with the bracket by engaging the lugs with the recesses described and then swinging it up into position and entering a thumb-operated set-screw *f*². By this construction the stock is disengaged by simply unscrewing the set-screw and swinging

it down until the lugs disengage from the bracket.

The rifle-barrel is built up of two or more tubes formed from strips of sheet metal, and to strengthen the breech end of the barrel I cut the blank for the outer shell wider at the rear end and bend the edges *a*⁷ outward, so that when the tube is formed the flat sides of these edges come together. I employ substantially the same construction for the forward end of the receiver, the edges *a*⁸ coming outside of the edges *a*⁷. I then connect these edges by a flat key G, which fits closely in a cross-channel cut through the several edges. After the key is driven into the channel I swage the outer edges over the sides of the key to hold it in.

The extractor H' consists of a stiff spring provided with a hook at the forward end to engage the cartridge and is held in engagement with the tube B by a loop *h* back of the ear H. *h*¹ is a pin through the free ends of the loop outside of the tube. The extractor thus is in the form of a spring-lever fulcrumed at the rear against the inside of the ear.

What I claim is—

1. In firearm construction, the combination of the receiver, the rifle-barrel set in the forward end of the receiver, reciprocating breech-block mechanism traveling within the receiver and the firing-pin and trigger mechanism carried by the breech-block mechanism, substantially as described.
2. The combination of the rifle-barrel, the receiver, the reciprocating breech-block mechanism traveling within the receiver, the trigger-case mounted on the firing-pin and traveling with the breech-block mechanism, substantially as described.
3. The combination of the receiver, the reciprocating breech-block mechanism traveling within the receiver slotted on the under side and trigger mechanism entering the said slot in the under side thereof, substantially as described.
4. The combination of the reciprocating breech-block mechanism provided with a slot, the firing-pin adapted to reciprocate in the breech-block mechanism, an arm fixed to the firing-pin and adapted to traverse the slot in the breech-block mechanism to hold the rod against rotation and the trigger-case suspended from the firing-pin and through the slot in the breech-block mechanism whereby the pin and trigger-case are held in alignment, substantially as described.
5. The combination of the breech-block mechanism, the firing-pin provided with a fixed collar, the trigger-case having a loose connection with the pin and a fixed connection with the breech-block mechanism, substantially as described.
6. The combination of the breech-block mechanism provided with a plug at one end, and the trigger-case engaged with said plug, substantially as described.
7. In firearm construction, the receiver, the

rifle-barrel set in the forward end of the receiver, the traveling breech-block mechanism, trigger mechanism reciprocating with the breech-block mechanism, the firing-pin and means for preventing the rotation of the firing-pin, substantially as described.

8. The combination of the reciprocating breech-block mechanism, a U-shaped link connecting the breech-block mechanism with the operating-lever, the lever, and the spring, one end of said spring engaging the breech-block mechanism, the other housed within the channel formed by the U-shaped link and bearing upon the same, locking the link when the breech-block is against the breech of the barrel, substantially as described.

9. The receiver provided with depending brackets formed integral therewith in combination with stock-plate provided with lugs

to engage the recesses in the brackets, together with means for securing the brackets to the stock-plates, substantially as described.

10. In firearm construction, the combination of the receiver, the barrel set in the forward end of the receiver, reciprocating breech-block mechanism traveling within the receiver, the plug *b'* supporting the trigger-case *b^e*, fitted in the rear end of the reciprocating breech-block mechanism, and the key *b^f* for locking the plug with the reciprocating breech-block mechanism, substantially as described.

In testimony whereof I sign this specification in the presence of two witnesses.

CLARENCE J. HAMILTON.

Witnesses:

S. E. THOMAS,
FRANK A. DINOE.