

[54] MODEL FOR TOOTH COLOR MATCHING

[76] Inventor: John G. Yerkes, Jr., 36 Gillett St., Hartford, Conn.

[22] Filed: June 8, 1972

[21] Appl. No.: 260,724

[52] U.S. Cl. .... 32/71

[51] Int. Cl. .... A61c 19/00

[58] Field of Search ..... 32/71

[56] References Cited

FOREIGN PATENTS OR APPLICATIONS

1,491,108 7/1969 Germany ..... 32/71

Primary Examiner—Louis G. Mancene

Assistant Examiner—J. Q. Lever

Attorney—Peter L. Costas

[57] ABSTRACT

Models for tooth color matching include a body member and a handle on which the body member is pivotally mounted. The body member is adapted for placement in a patient's mouth in front of a prepared tooth, and has a sidewall portion with a generally concave inner surface providing an obstruction-free central area to accommodate the prepared tooth; an enamel-simulating veneer material may be provided on the body member if so desired.

8 Claims, 8 Drawing Figures

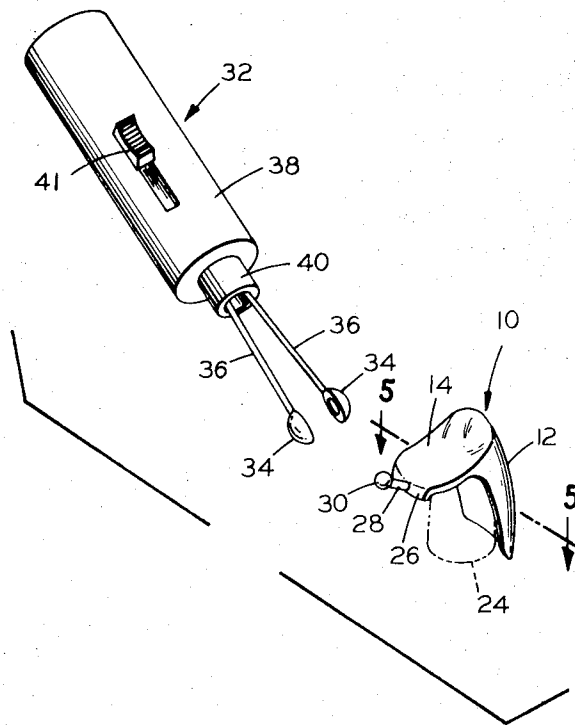

PATENTED JUL 31 1973

3,748,741

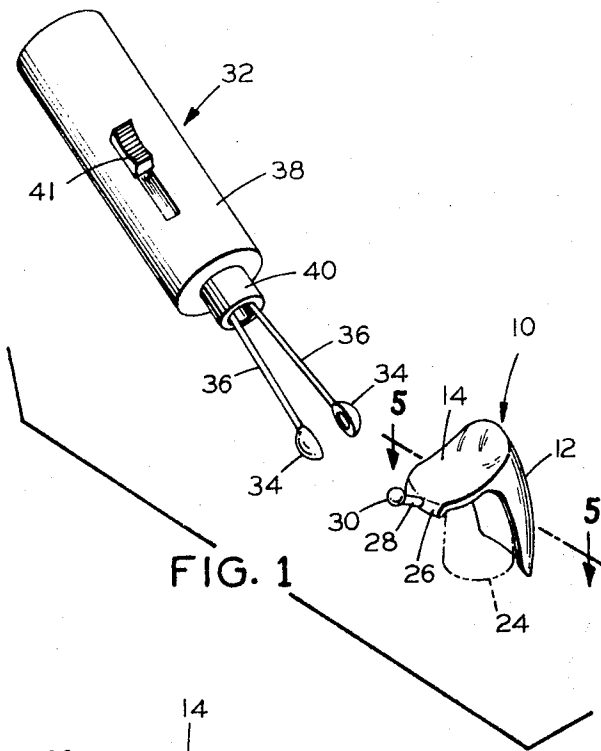

FIG. 1

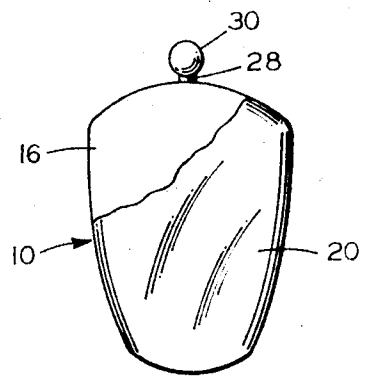

FIG. 2

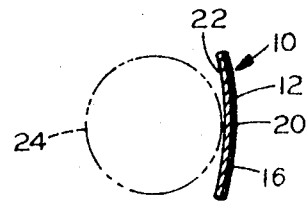

FIG. 5

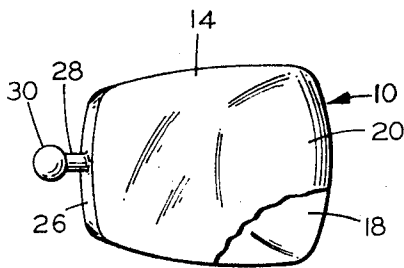

FIG. 3

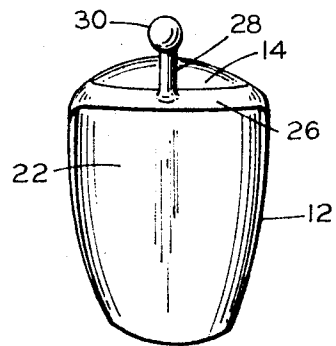

FIG. 4

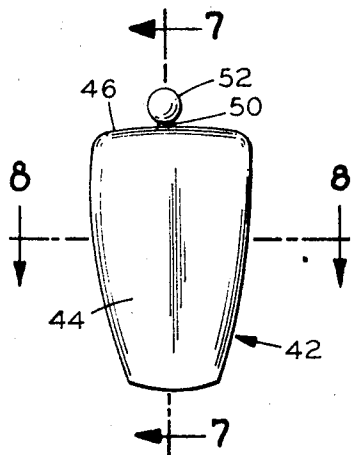

FIG. 6

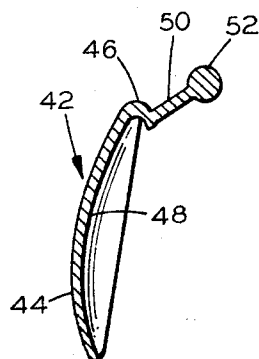

FIG. 7

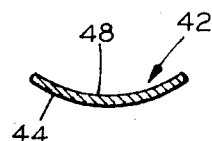

FIG. 8

## MODEL FOR TOOTH COLOR MATCHING

### BACKGROUND OF THE INVENTION

In the course of fitting veneer crowns, pontics and dentures, the dentist commonly utilizes a color guide in an effort to duplicate as closely as possible the color of the patient's natural teeth. Typically, such a guide includes a set of samples which provide a color gradation within which an approximate match may be made, and each sample generally comprises a tooth-simulating body portion which has a centrally located, rearwardly projecting stud on which a short handle is pivotally mounted.

Although such guides are satisfactory in some respects, they do suffer from a number of significant deficiencies. Firstly, since the body portion of the sample is generally configured to simulate a real tooth, the presence in the patient's mouth of a tooth prepared to receive a crown will cause interference with the sample. This will cause displacement of its colored surface from the ultimate location at which the face of the artificial tooth is to reside, making comparisons with adjacent teeth difficult and causing shadows and other unnatural light variants to affect appearance. Furthermore, any handle-engaging stud or extension which is present on the central rear portion of the sample will obviously increase the level of interference and displacement.

Secondly, the presently available color guides afford only a limited number of samples for comparison and, since it is uncommon for a sample to exactly match the natural coloration, the dentist is required to judge the degree of deviation and to then attempt to communicate this information to the laboratory. Increasing the number of samples available to the dentist does not provide a practical solution to this problem in view of the large number of shades available from a number of manufacturers, each of whom offers his own independent line of colored materials. Not only would it require a very large inventory of samples to adequately represent all of the colors available, but also an inordinate amount of the dentist's time would be expended in locating the best color match with such an approach.

Accordingly, it is an object of the present invention to provide a model adapted for placement in the patient's mouth in any of numerous positions for accurate color matching.

It is also an object of the invention to provide a device which is adapted for coating with a tooth enamel-simulating veneer material to enable the facile preparation of color guide models by dentists or dental lab technicians.

### SUMMARY OF THE INVENTION

It has now been found that the foregoing and related objects of the present invention are readily attained in a combination comprising a body member and a handle member mounting the body member for pivotal movement relative thereto. The body member has a thin sidewall portion adapted for placement in a patient's mouth in front of a prepared tooth with its outer face in substantial alignment with the faces of existing teeth adjacent thereto, and with a lower edge adjacent the patient's gums. It has a generally concave inner surface providing an obstruction-free central area extending upwardly from the lower edge of the sidewall portion, so as to accommodate the prepared tooth therewithin,

and the outer face of the sidewall portion is adapted for coating with a tooth enamel-simulating veneer material. Handle-engaging means is provided on the body member at a location spaced from the central area, and the handle member is coupled therewith to mount the body member thereon; preferably, the handle member is disengageably secured to the handle-engaging means.

Generally, the outer face of the sidewall portion will be configured to simulate the corresponding face of a natural tooth. The handle-engaging means may comprise a knob extending upwardly and inwardly from adjacent an upper portion of the sidewall portion, and it may have a ball-shaped element on its free end which is seated in a socket provided by the handle member.

The body member may additionally include a thin top wall portion which extends laterally inwardly from an upper edge portion of the sidewall portion to provide a model for color matching of posterior teeth. The top wall portion thereby provides an occlusal surface which is, like the outer face of the sidewall portion, adapted for coating with a tooth enamel-simulating veneer material. Generally, the top wall portion of such an assembly will have the handle engaging means thereon, and preferably the handle-engaging means comprises a knob extending upwardly from the top wall portion.

Most desirably, the invention provides a complete color matching model which has a coating of colored tooth enamel-simulating veneer material on at least the outer face of the sidewall portion. The body member may be of metallic construction with the veneer material being provided by a porcelain, or the material of the body member and the veneer material may both be synthetic resins.

### BRIEF DESCRIPTION OF THE DRAWINGS

FIG. 1 is an isometric view of a model for tooth color matching embodying the present invention, with the body member positioned over a prepared posterior tooth, shown in phantom line, and with the handle detached for clarity of illustration;

FIG. 2 is a front elevational view thereof showing the buccal surface of the body member, with an area of veneer material removed to expose the underlying surface;

FIG. 3 is a plan view of the body member showing the occlusal surface, again with an area of veneer material removed;

FIG. 4 is a rear elevational view of the body member;

FIG. 5 is a sectional view along line 5—5 of FIG. 1;

FIG. 6 is a front elevational view of an uncoated body member used for color matching of anterior teeth and showing the labial and incisal surfaces thereof;

FIG. 7 is a sectional view of the body member of FIG. 6 along line 7—7 thereof; and

FIG. 8 is a sectional view along line 8—8 of FIG. 6.

### DETAILED DESCRIPTION OF THE ILLUSTRATED EMBODIMENTS

Turning now in detail to FIGS. 1 - 5 of the appended drawing, therein illustrated is a tooth color-matching model embodying the present invention and including a body member, generally designated by the numeral 10. The body member 10 includes a sidewall portion 12 and a top wall portion 14 extending generally perpendicularly thereto from the upper edge thereof. The sidewall portion 12 has an outer face or buccal surface

16, and the top wall portion 14 has an occlusal surface or top face 18, each of the faces 16, 18 being coated with a layer 20 of veneer material. As is seen in FIGS. 1 and 5, the concave inner surface 22 of the sidewall portion 12 permits the body member 10 to be closely accommodated to the prepared posterior tooth 24, which is shown in phantom line therein.

Extending upwardly and inwardly from adjacent the inner edge 26 of the top wall portion 14 of the body member 10 is a knob consisting of a shank 28 with a ball 30 in its free end. A handle member, generally designated by the numeral 32, consists of a pair of opposed, hemispherical elements 34, which are affixed to outwardly biased legs 36. The legs are mounted within the handle 38, which also contains a slidable collar 40 connected to a manual slide operator 41. As will be appreciated, the handle 32 is assembled with the body member 10 by positioning the ball 30 between the hemispherical elements 34, and by thereafter moving the collar 40 to close the elements 34 about the ball 30. When so engaged, the body member 10 may be pivoted about the axis of the shank 28, and may also be moved in an arc between the elements 34.

As will be appreciated, the assembly illustrated permits the body member 10 to be placed over the prepared tooth 24 with a high degree of convenience and positional flexibility. This results not only from the location of the knob intermediate the sides of the top wall 14, but also from the wide latitude of movement of the body member 10 with respect to the handle member 32. It will also be appreciated that the concave inner surface 22 of the sidewall portion 12 permits the body member 10 to be seated closely adjacent the prepared tooth 24, and permits alignment of the buccal surface 16 with the outer faces of existing teeth (not shown) adjacent the prepared tooth 24.

Turning now in detail to FIGS. 6 - 8, a second embodiment of the invention, adapted for use in connection with anterior teeth, is illustrated. It consists essentially of a sidewall portion, generally designated by the numeral 42, which has a labial or outer face 44 and substantially linear incisal surface or top edge 46. As in the body member 10 of FIGS. 1 - 5, the sidewall portion 42 has a concave inner surface 48 for the accommodation of a prepared tooth, and it has a knob, consisting of a shank 50 and ball 52, which projects inwardly and upwardly from a central location adjacent the top edge 46. As will be appreciated, the knob is adapted for engagement with a handle member 32 in the manner previously described, and the location thereof leaves the central area of the inner surface 48 free from obstructions to permit the close placement of the model, in accordance with the novel concepts hereof.

The dimensions and configuration of the body members of the present models will depend upon a number of factors, including the intended usage and the materials of fabrication. As shown in the drawings, two styles will generally be provided, one of which is particularly adapted for use in matching anterior teeth and the other of which is especially suited for use in connection with posterior teeth. The materials employed for the body member will most often be the same as those which are utilized for the foundation of the artificial tooth to be prepared, so as to ensure the accurate reproduction of coloration in the finished product. Accordingly, when the artificial tooth is to have a porce-

lain veneer the body member will normally be of metallic fabrication, and (in the present state of the art) it will generally be made of a gold alloy due to the high degree of compatibility of such a combination and the widely recognized advantages of artificial teeth of such construction. On the other hand, when the veneer material is to be of a synthetic resin, the material utilized for the body member must be compatible therewith and may be a synthetic resin or a base metal. Generally, fabricating the body member from a base metal will produce the most satisfactory results in such an instance.

While porcelain coatings are generally most satisfactorily produced upon smooth, continuous surfaces, various undercut configurations or screenlike elements may be utilized in body members which are intended to carry coatings of synthetic resins. The thickness of material in the base member must be sufficient for adequate strength and durability and, in the case of porcelain/metal combinations, it must possess sufficient structural strength to withstand deformation upon cooling of the porcelain coating. Accordingly, noble metal alloy thicknesses of about one-third to one-half mm are typical. The dimensions of body members produced from synthetic resins or from base metals are less significant due to both material costs and also structural factors; however, in any event they should not be unduly large since oversized dimensions would tend to displace the surfaces from alignment with adjacent teeth and thereby tend to frustrate the objects of the invention.

Although the type of handle member illustrated is highly desirable from the standpoints of simplicity and convenience of use, the invention is by no means to be construed to be limited in this respect, and other types of handle members may obviously be substituted. In some instances, it may be desirable to utilize a handle member which is itself jointed, to afford even more latitude in positioning the body member, and numerous variations will readily occur to those skilled in the art. Whereas the handle member may be permanently joined to the body member, and this may be most convenient in the dentist's working set, disengageable handles will generally be required to enable firing or other treatment of models in preparation.

Regardless of the particular configuration of the handle-engaging means furnished by the body member, it must be such as will leave the central area of the inner surface free from obstruction, so as to enable the snug placement of the body member against a prepared tooth. Spacing the engagement knob from the central area, and particularly so that it extends upwardly and inwardly from the sidewall (or top wall when present), satisfies this requirement in a very simple and convenient manner, and is accordingly a preferred construction. Moreover, the location of the engagement means intermediate the side edges of the body member also serves to greatly facilitate its placement in virtually any desired position within the patient's mouth.

By providing a body member that is adapted for coating, the color matching procedure is rendered much more facile and accurate. Thus, after obtaining an initial rough match from the patient's natural teeth, the dentist or laboratory technician can himself coat the body member based upon the available information to produce one or more completed models, with the model then being used for direct comparison and con-

firmation of coloration. The advantages of such an approach over prevailing practices, whereby the final product is often produced based only upon approximations and verbal descriptions, will be evident. Of course, it will be clear from disclosure hereof that complete models (and normally sets thereof) carrying colored coatings may be furnished in accordance herewith, and that such models may be intended for color modification by the subsequent application of stains, glazes, or the like.

Thus, it can be seen that the present invention provides a model adapted for placement in the patient's mouth in any of numerous positions for accurate color matching. It also provides a device which is adapted for coating with a tooth enamel-simulating veneer material, so as to enable the facile preparation of color guide models by dentists or dental laboratory technicians. The models hereof may provide a means by which color matching of occlusal surfaces can accurately be accomplished, which is not believed to have been a feature of any prior art color-matching samples. Finally, it will be appreciated that variations of configuration of the models may be made without departure from the novel concepts hereof, and that modifications of configuration as well as of coloration may be made by the technician or dentist. Thus, the body members may be ground to produce smaller sizes or, for example, to produce a cuspid from an incisor model by bevelling of the corners thereof.

Having thus described the invention, I claim:

1. In a model for tooth color matching, the combination comprising: a body member having a thin sidewall portion adapted for placement in a patient's mouth in front of a prepared tooth with its outer face in substantial alignment with the faces of existing teeth adjacent thereto and with a lower edge adjacent the patient's gums, said sidewall portion having a generally concave inner surface providing an obstruction-free central area extending upwardly from said lower edge of said sidewall portion for the accommodation of the prepared

tooth therewithin and said outer face thereof being adapted for coating with a tooth enamel-simulating veneer material, said body member also having a top wall portion adapted to seat on the top edge of the prepared tooth to mount said body member on the prepared tooth and handle-engaging means on said top wall portion and spaced from said central area; and a handle member releasably coupled with said handle-engaging means and mounting said body member for pivotal movement relative thereto.

2. The model of claim 1 wherein said outer face of said sidewall portion is configured to simulate the corresponding face of a natural tooth.

3. The model of claim 1 wherein said handle-engaging means comprises a knob extending upwardly and inwardly from adjacent an upper portion of said sidewall portion and has a ball-shaped element on its free end, and wherein said handle member includes a socket in which said ball-shaped element of said handle-engaging means is seated.

4. The model of claim 1 wherein said body member top wall portion is thin and extends laterally from the upper edge portion of said sidewall portion to provide an occlusal surface on said body member, said occlusal surface also being adapted for coating with a tooth enamel-simulating veneer material.

5. The model of claim 4 wherein said handle-engaging means comprises a knob extending upwardly from said top wall portion.

6. The model of claim 1 wherein said model additionally includes a coating of colored tooth enamel-simulating veneer material on said outer face.

7. The model of claim 6 wherein said body member is of metallic construction and wherein said veneer material is a porcelain.

8. The model of claim 6 wherein the material from which said body member is fabricated and said veneer material are both synthetic resins.

\* \* \* \* \*

45

50

55

60

65