

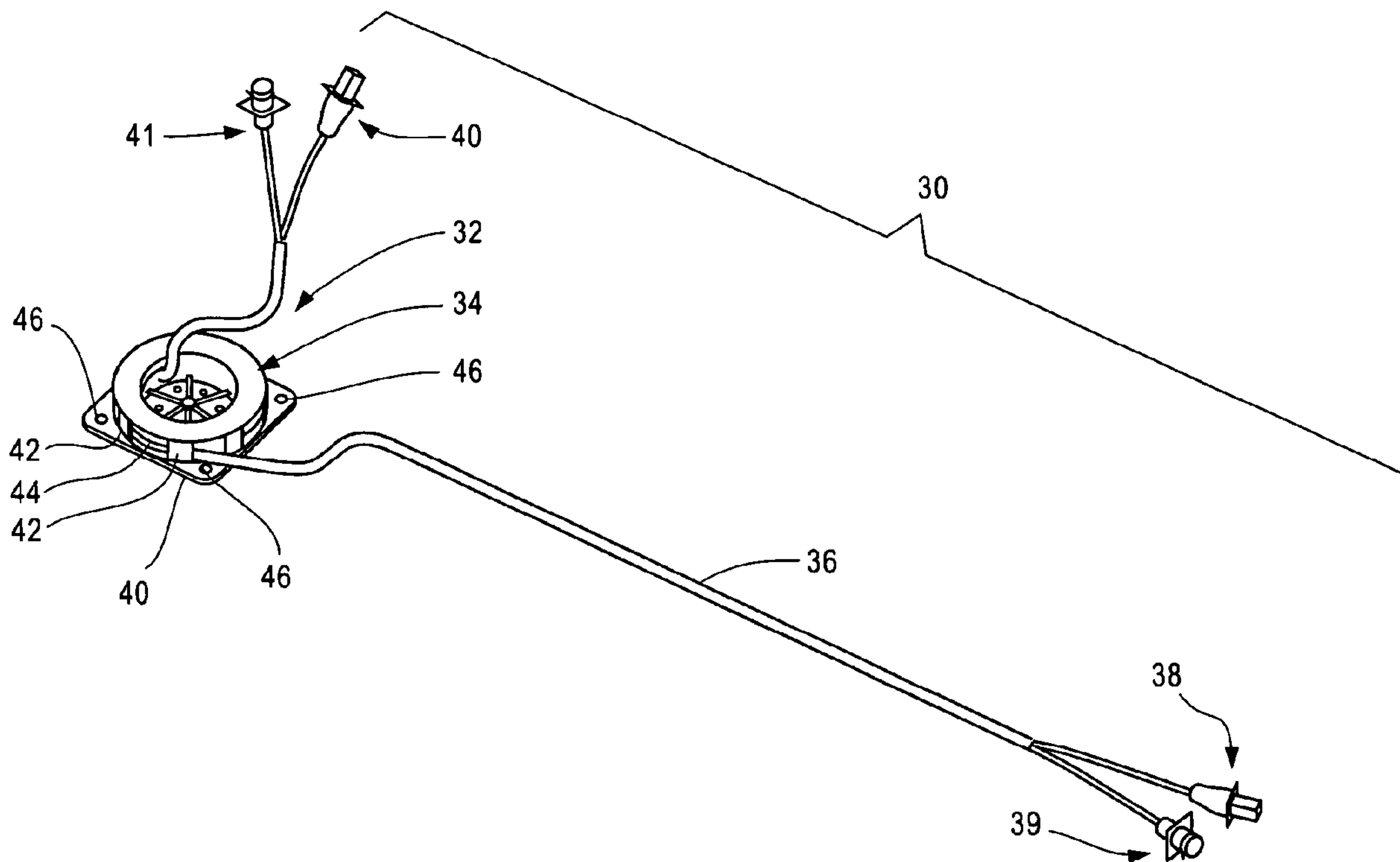

(86) Date de dépôt PCT/PCT Filing Date: 2010/04/01
 (87) Date publication PCT/PCT Publication Date: 2010/10/07
 (45) Date de délivrance/Issue Date: 2014/06/17
 (85) Entrée phase nationale/National Entry: 2011/09/30
 (86) N° demande PCT/PCT Application No.: US 2010/000972
 (87) N° publication PCT/PCT Publication No.: 2010/114607
 (30) Priorité/Priority: 2009/04/03 (US61/166,248)

(51) Cl.Int./Int.Cl. *H01B 13/04* (2006.01),
H01B 11/06 (2006.01), *H01B 13/22* (2006.01),
H02G 11/02 (2006.01)
 (72) Inventeurs/Inventors:
 BURKE, PAUL C., US;
 DUBOIS, JAMES L., US
 (73) Propriétaire/Owner:
 TELEFONIX, INCORPORATED, US
 (74) Agent: FINLAYSON & SINGLEHURST

(54) Titre : CABLE USB ET PROCEDE POUR SA FABRICATION
 (54) Title: USB CABLE AND METHOD FOR PRODUCING THE SAME



(57) Abrégé/Abstract:

A method and apparatus for producing a USB cable capable of being fed out of and returned to a cable reel is disclosed along with a cable reel that houses the cable and provides connectivity for the cable.

(12) INTERNATIONAL APPLICATION PUBLISHED UNDER THE PATENT COOPERATION TREATY (PCT)

(19) World Intellectual Property Organization
International Bureau(43) International Publication Date
7 October 2010 (07.10.2010)(10) International Publication Number
WO 2010/114607 A3(51) International Patent Classification:
H02G 11/02 (2006.01)(21) International Application Number:
PCT/US2010/000972(22) International Filing Date:
1 April 2010 (01.04.2010)

(25) Filing Language: English

(26) Publication Language: English

(30) Priority Data:
61/166,248 3 April 2009 (03.04.2009) US(71) Applicant (for all designated States except US): **TELEFONIX, INCORPORATED**; 2340 Ernie Krueger Circle, Waukegan, IL 60087 (US).(72) Inventors: **BURKE, Paul, C.**; 2340 Ernie Krueger Circle, Waukegan, IL 60087 (US). **DUBOIS, James, L.**; 16436 Lakeside Drive, Lockport, IL 60441 (US).(74) Agent: **GASEY, Arthur, A.**; Niro, Haller & Niro, 181 W. Madison, Suite 4600, Chicago, IL 60602 (US).

(81) Designated States (unless otherwise indicated, for every kind of national protection available): AE, AG, AL, AM, AO, AT, AU, AZ, BA, BB, BG, BH, BR, BW, BY, BZ, CA, CH, CL, CN, CO, CR, CU, CZ, DE, DK, DM, DO,

DZ, EC, EE, EG, ES, FI, GB, GD, GE, GH, GM, GT, HN, HR, HU, ID, IL, IN, IS, JP, KE, KG, KM, KN, KP, KR, KZ, LA, LC, LK, LR, LS, LT, LU, LY, MA, MD, ME, MG, MK, MN, MW, MX, MY, MZ, NA, NG, NI, NO, NZ, OM, PE, PG, PH, PL, PT, RO, RS, RU, SC, SD, SE, SG, SK, SL, SM, ST, SV, SY, TH, TJ, TM, TN, TR, TT, TZ, UA, UG, US, UZ, VC, VN, ZA, ZM, ZW.

(84) Designated States (unless otherwise indicated, for every kind of regional protection available): ARIPO (BW, GH, GM, KE, LR, LS, MW, MZ, NA, SD, SL, SZ, TZ, UG, ZM, ZW), Eurasian (AM, AZ, BY, KG, KZ, MD, RU, TJ, TM), European (AT, BE, BG, CH, CY, CZ, DE, DK, EE, ES, FI, FR, GB, GR, HR, HU, IE, IS, IT, LT, LU, LV, MC, MK, MT, NL, NO, PL, PT, RO, SE, SI, SK, SM, TR), OAPI (BF, BJ, CF, CG, CI, CM, GA, GN, GQ, GW, ML, MR, NE, SN, TD, TG).

Published:

- with international search report (Art. 21(3))
- before the expiration of the time limit for amending the claims and to be republished in the event of receipt of amendments (Rule 48.2(h))

(88) Date of publication of the international search report:
20 January 2011

(54) Title: USB CABLE AND METHOD FOR PRODUCING THE SAME

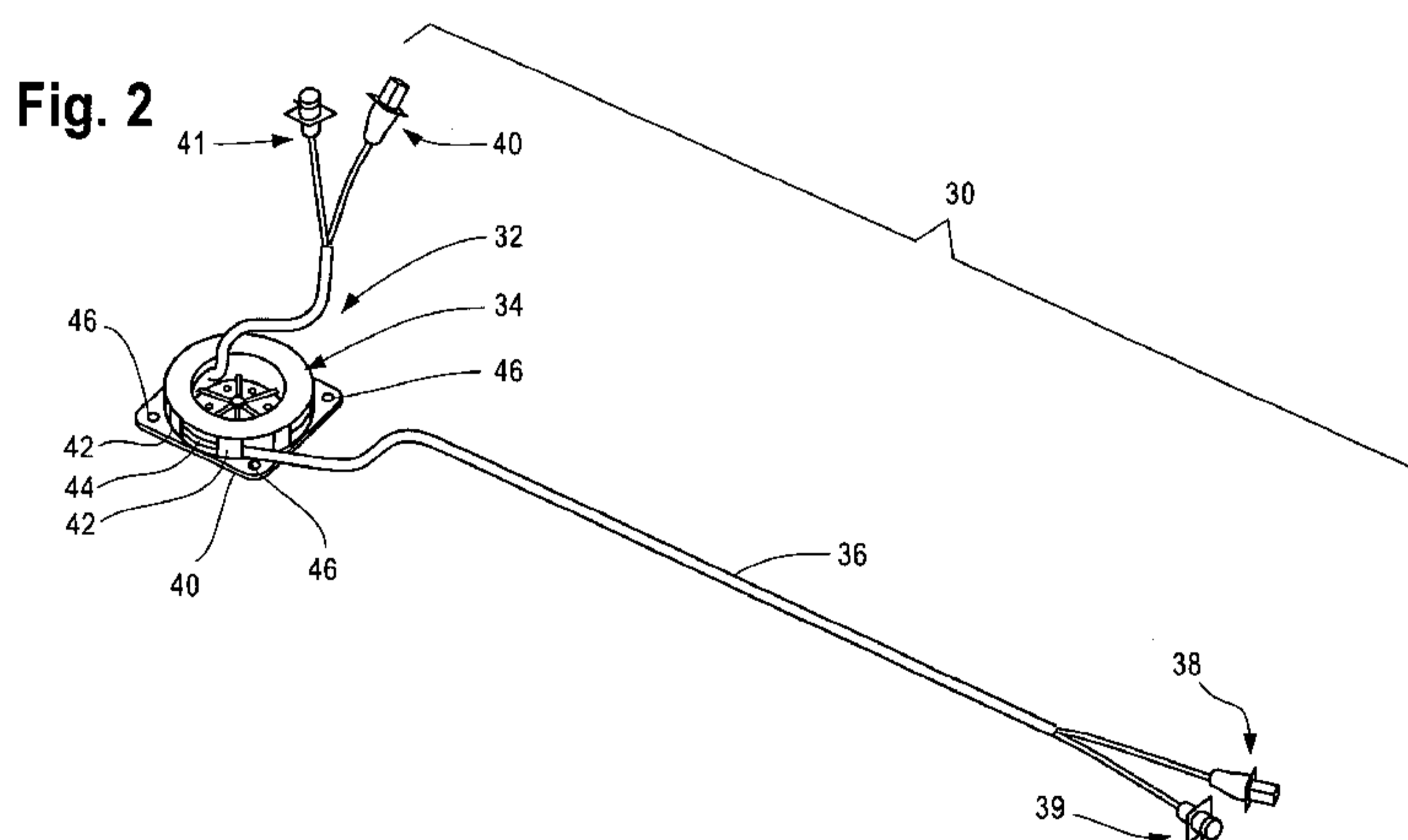

(57) Abstract: A method and apparatus for producing a USB cable capable of being fed out of and returned to a cable reel is disclosed along with a cable reel that houses the cable and provides connectivity for the cable.

USB CABLE AND METHOD FOR PRODUCING THE SAME**FIELD OF THE INVENTION**

The present invention relates generally to a USB cord, and more specifically to a USB cord coupled to a retractable reel.

BACKGROUND OF THE INVENTION

Universal Serial Bus, or “USB” is a commonly used term that refers to a standard for connecting two electronic devices or for connecting a device and a host computer. Using USB technology, a plurality of peripherals can be connected using a single standardized interface socket. Plug-and-play capabilities may also be improved by permitting hot swapping – that is, by permitting devices to be connected and disconnected without rebooting the computer or turning off the device. Other features of USB technology include providing power to low-consumption devices, eliminating the need for an external power supply, and allowing many devices to be used without requiring manufacturer-specific device drivers to be installed.

In certain scenarios, it may be desirable to have a USB cord on a retractable reel, such that the cord can be extended and retracted into a reel depending on how and when it is being used.

SUMMARY OF THE INVENTION

The present invention relates to one or more of the following features, elements or combinations thereof.

In one embodiment, a retractable USB reel includes a pair of data wires placed next to each other and overlaid with an EMI/RFI shield. The data wires may be twisted around each other. Conductors can also be placed and twisted around the data wires or put in parallel relationship with the data wires. The resulting conglomerate of wires and shields can then be covered with a low friction substance and then an EMI/RFI shield.

In another embodiment, a cord reel is provided with an electrically conductive material. The cord reel is configured to carry a stationary USB coil and a movable USB coil, such that the two USB coils are in communication with each other.

In a further embodiment, a universal serial bus cord reel apparatus includes a cable. The cable includes first and second data wires adjacent to each other, and twisted around each other at approximately four twists per inch, a first braided shield surrounding the first and second data wires to prevent electromagnetic or radio frequency interference, two or more additional conductors adjacent to the shield surrounding the first and second data wires, the additional wires being twisted about the shield at approximately two twists per inch, a polytetrafluoroethylene cover enclosing the additional conductors and first and second data wires, and a second shield enclosing the polytetrafluoroethylene cover, whereby the cable has an impedance of approximately 90 ohms. A universal serial bus connector at each end of the cable is included, along with a housing, a reel attached to and rotatable with respect to the housing for accepting the cable, a spring mounted between the housing and the reel for biasing the rotation of the reel in one direction for retracting the cable, and a ratchet attached to the housing for selectively restraining rotation of the reel whereby the cable may be maintained in an extended position, or retracted and wound on the reel.

2A

A method for manufacturing a universal serial bus cable is also provided which includes the steps of: (1) placing first and second data wires adjacent to each other, (2) twisting the first and second data wires about each other at approximately four twists per inch, (3) covering the twisted first and second data wires with a braided shield, (4) placing one or more additional data wires in close proximity to the shield, (5) forming a circular cross-section of the first and second data wires, the braided shield, and the one or more additional data wires by either twisting or helically fluting the one or more additional data wires about the braided shield at approximately two twists per inch, so that the resulting structure has a bend radius of at least approximately 55 millimeters, (6) coating the braided shield and one or more additional data wires with a low-friction substance, (7) covering the low-friction substance with a second shield resisting radio-frequency and electromagnetic interference, so that the resulting structure has an impedance of approximately 90 ohms and a signal rate of at least approximately 1.5 megabytes per second.

BRIEF DESCRIPTION OF THE DRAWINGS

Fig. 1 is a top view of a flat USB connecting cable according to one embodiment of the invention;

Fig. 2 is a perspective view of a USB cord reel according to one embodiment of the invention, the USB cord reel showing the inner elements of the cord reel;

Fig. 3 is a perspective view of a USB cord reel; and

Fig. 4 is a perspective view of one embodiment of the invention without a jacket.

DETAILED DESCRIPTION OF EMBODIMENTS OF THE INVENTION

As can be seen in Fig. 1, a flat USB cable 10 can include a first data wire 12 and a second data wire 14. First and second data wires 12, 14 are illustratively positioned adjacent to each other and twisted around each other. Other wires 16, 18, 20, 22, 24, 26, and 28 may also be positioned alongside first and second data wires 12, 14. In the illustrated example, other wires 16, 18, 20, 22, 24, 26 and 28 are arranged in a substantially parallel single row on either or both sides of first and second data wires 12, 14. The various wires 12, 14, 16, 18, 20, 22, 24, 26, and 28 are held together with a threaded material.

The present invention comprises a cable management system for organizing and managing a USB cable, and may optionally comprise other cables and / or wires coupled therewith. Such a management system facilitates the use and storage of a USB cord in a variety of environments, including passenger vehicles.

As can be seen in Fig. 2, the illustrative cable management system 30 comprises a cable storage unit 32, a cable reel 34, a cable 36, and a USB connector 38. A second USB connector or other electronic connector 40 may also be provided at the other end of cable management system 30. Additional connectors 39, 41 may also be provided. The cable storage unit 32 may have a tension element disposed within and coupled to reel 34, the tension element functioning to resist extraction of the cable 36 from the housing.

The cable storage unit 32 may be configured for mounting on a seat, a vehicle, or any other type of structure. Similar disclosures of cable storage units and cable management systems can be found in U.S. Patent No. 5,094,396 to Burke, the subject matter of which may be

referred to for further details, and U.S. Patent Application No. 2007/0262185 to Burke, the subject matter of which may also be referred to for further details.

In the embodiment shown in Figs. 2-3, cable storage unit 32 includes a spool or reel 34 upon which a portion of the length of the cable 36 is wound. The cable storage unit 32 also includes a base or housing 40. The housing 40 may include a plurality of circumferentially spaced tabs 42 configured to enable reel 34 to be rotatable relative to housing 40. Additionally, tabs 42 may be configured to retain the wound portion 44 of the cable against reel 34. The inside surface of housing 40 may also be coated with an electrically conductive coating.

Housing 40 may also provide mounting holes 46 to facilitate mounting of the cable storage unit 32 underneath a passenger seat or in some other location. It should be understood that cable 36 may include multiple types of wires and / or connectors. For example, in the embodiments shown in Figs. 2-3, two connectors 38, 39 and 40, 41 appear at each end of the cable management system 30.

The manufacture and construction of cable 36 is illustratively as follows and can be seen in Fig. 4. A pair of USB data wires is placed next to each other in such a way as to remain substantially immobile relative to each other. For example, it is contemplated that the USB data wires are twisted around each other at a rate of approximately four twists per inch. The USB data wires can then be overlaid with a braided shield 48. Shield 48 functions to substantially remove void spaces between the data wires and may further assist in protecting the USB data wires from interference from any adjoining wires and appliances. In one embodiment, the shield is a helically braided, served shield. Collectively, the USB data wires and the shield are referred to herein as a "first construct."

Additional conductors / data wires are placed in close spatial relationship to the first construct to create a second construct having a cross section defining a substantially circular periphery. The additional conductors may be twisted or fluted helically about the first construct at a lay rate of two twists per inch. Alternatively, the additional conductors may be positioned alongside and parallel to the first construct, without twisting around the first construct. If desirable, "core fillers" may also be used to create a cord that is substantially round in construction. This "second construct" will ideally be formed to have a bend radius of 55 mm or greater.

The second construct is then covered with a low friction substance such as PFE, followed by second shield, such as an EMI / RFI shield. This process can ideally produce a USB cable with a bend radius of 55 mm or greater, a length of at least five meters, and a signal rate of at least 1.5 Mb.

It is also of interest to provide a USB cord that has sufficient impedance for the operation of electronic devices and data components. A suggested nominal impedance for most data applications is 90 Ohms. Accordingly, one of the goals of the disclosed embodiment is to manufacture a USB cord that allows for approximately the illustrative 90 Ohms impedance.

It is observed that impedance is affected by physical and geometric properties of the wires and the constructs. The spacing between the wires, as well as the wall thickness of the wire insulation is significant. Bending the wires also affects impedance. Accordingly, it is significant to hold the USB data wires in a substantially uniform manner regardless of how the USB cord is positioned or bent.

Additional conductors / wires that are positioned along the USB wires can also affect impedance. Therefore, the position of such additional conductors and the shield between the conductors and the USB wires are considerations when constructing the USB cord. An additional shield around the non-USB conductors may also be desirable. Finally, a braided nylon jacket may be formed on top of entire bundle. This nylon jacket may affect impedance by putting pressure on the underlying data wires. Furthermore, in a "double served shield" embodiment, impedance may also be affected.

The following chart shows various impedances and the resulting decline in impedances in selected "P3" embodiments. The term "no jacket" means no nylon jacket was used. The term "jacket" refers to a nylon-braided jacket. Single serve and double serve refer to the number of shields around the constructs inside the cord.

	No Jacket		w/Jacket	90Ω diff.
P3 Core Shield	96Ω →		88.4Ω →	1.6Ω
	↓	7.6Ω		
P3 Core Shield + Single Serv	3.3Ω 92.7Ω →		87.6Ω →	2.4Ω
	↓	5.1Ω		
P3 Core Shield + Double Serv	8.1Ω 84.6Ω →		82Ω →	8Ω
		2.6Ω		

From the data shown above, it can be seen that a data wire with higher impedance must be used in order to result in a 90 Ohm impedance. Additional notes relating to the construction of the USB cord can be found in Exhibit A, attached hereto and may be referred to for further details.

While the disclosure is susceptible to various modifications and alternative forms, specific exemplary embodiments thereof have been shown by way of example in the drawings and have herein been described in detail. It should be understood, however, that there is not intent to limit the disclosure to the particular embodiments disclosed, but on the contrary, the intention is to cover all modifications, equivalents, and alternatives falling within the scope of the disclosure.

What is claimed is:

1. A universal serial bus cord reel apparatus comprising:

a cable, the cable comprising a) first and second data wires adjacent to each other, and twisted around each other at approximately four twists per inch; b) a first braided shield surrounding the first and second data wires to prevent electromagnetic or radio frequency interference; c) two or more additional conductors adjacent to the shield surrounding the first and second data wires, the additional wires being twisted about the shield at approximately two twists per inch; d) a polytetrafluoroethylene cover enclosing the additional conductors and first and second data wires; and e) a second shield enclosing the polytetrafluoroethylene cover; whereby the cable has an impedance of approximately 90 ohms;

a universal serial bus connector at each end of the cable;

a housing;

a reel attached to and rotatable with respect to the housing for accepting the cable;

a spring mounted between the housing and the reel for biasing the rotation of the reel in one direction for retracting the cable;

a ratchet attached to the housing for selectively restraining rotation of the reel whereby the cable may be maintained in an extended position, or retracted and wound on the reel.

2. A method for manufacturing a universal serial bus cable comprising the steps of:

placing first and second data wires adjacent to each other;

twisting the first and second data wires about each other at approximately four twists per inch;

covering the twisted first and second data wires with a braided shield;

placing one or more additional data wires in close proximity to the shield;

forming a circular cross-section of the first and second data wires, the braided shield, and the one or more additional data wires by either twisting or helically fluting the one or more additional data wires about the braided shield at approximately two twists per inch, so that the resulting structure has a bend radius of at least approximately 55 millimeters;

coating the braided shield and one or more additional data wires with a low-friction substance;

covering the low-friction substance with a second shield resisting radio-frequency and electromagnetic interference, so that the resulting structure has an impedance of approximately 90 ohms and a signal rate of at least approximately 1.5 megabytes per second.

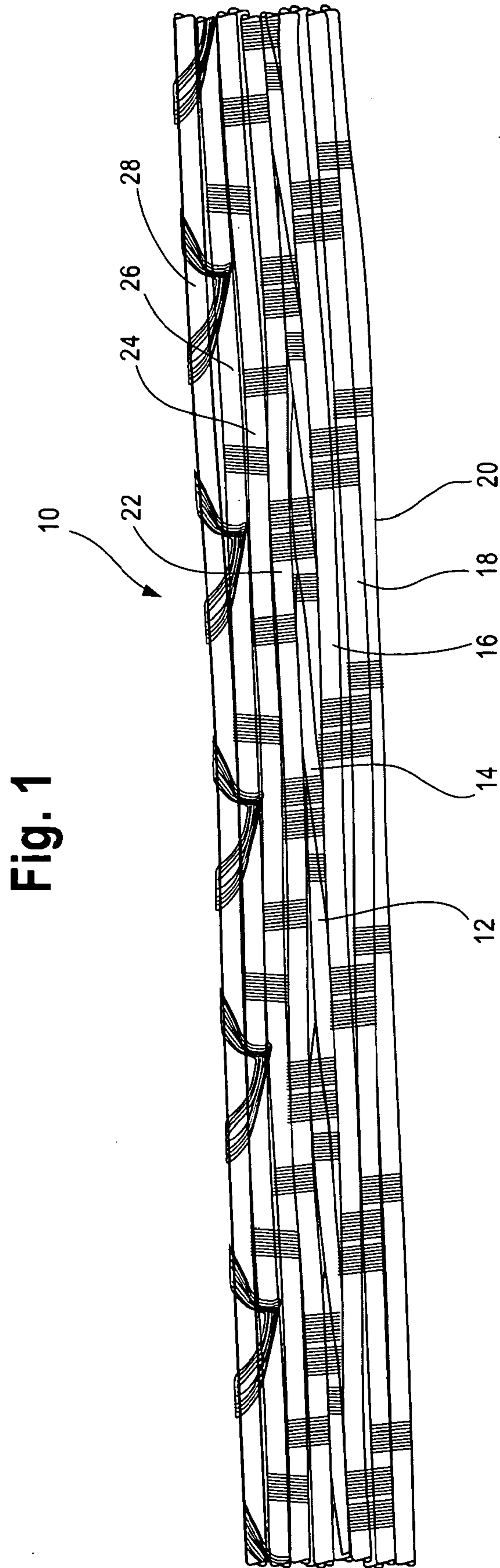

Fig. 1

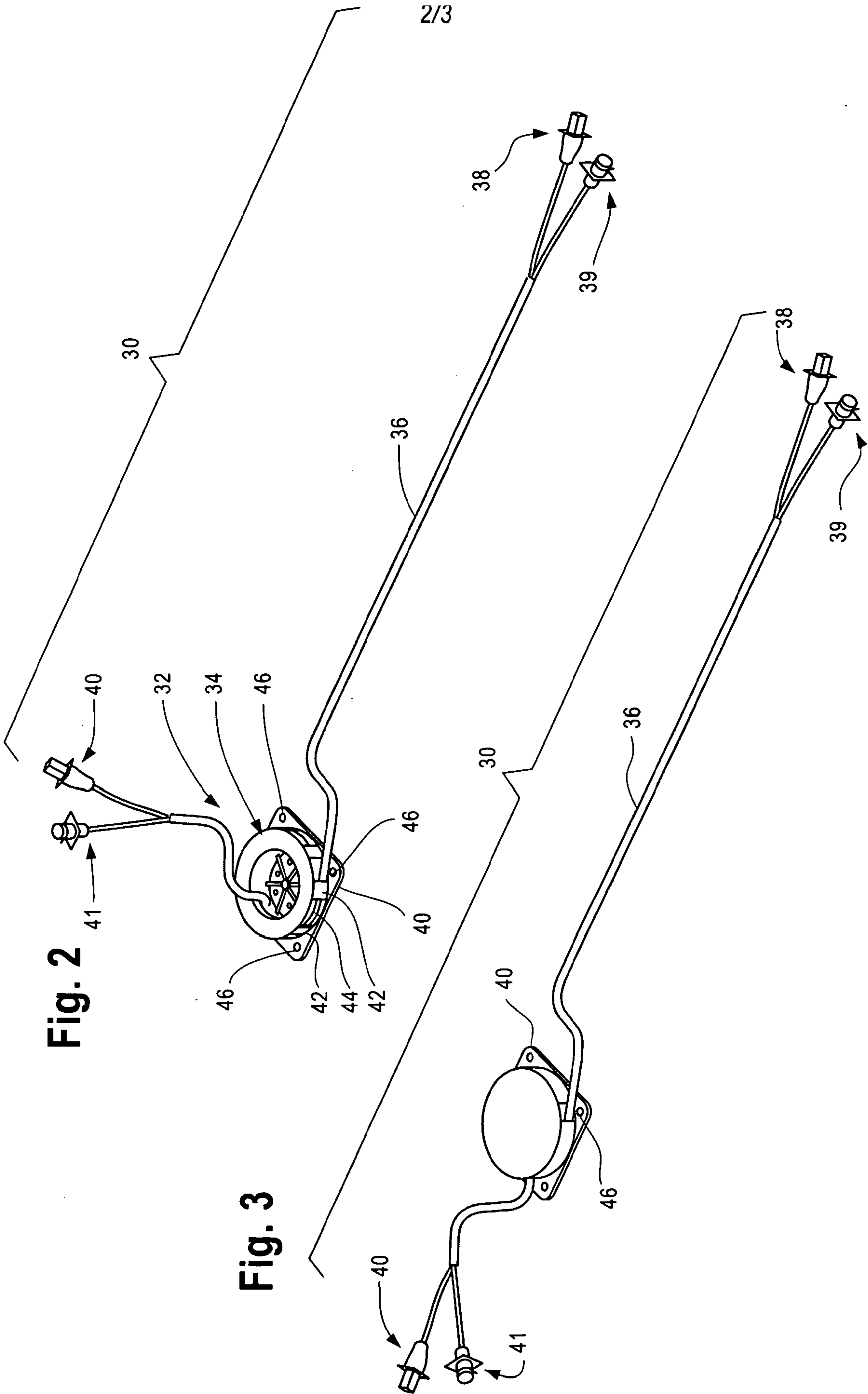

Fig. 2

Fig. 3

Fig. 4

