

No. 682,563.

Patented Sept. 10, 1901.

J. NORTHROP.  
FILLING REPLENISHING LOOM.

(Application filed Apr. 11, 1901.)

(No Model.)

2 Sheets—Sheet 1.

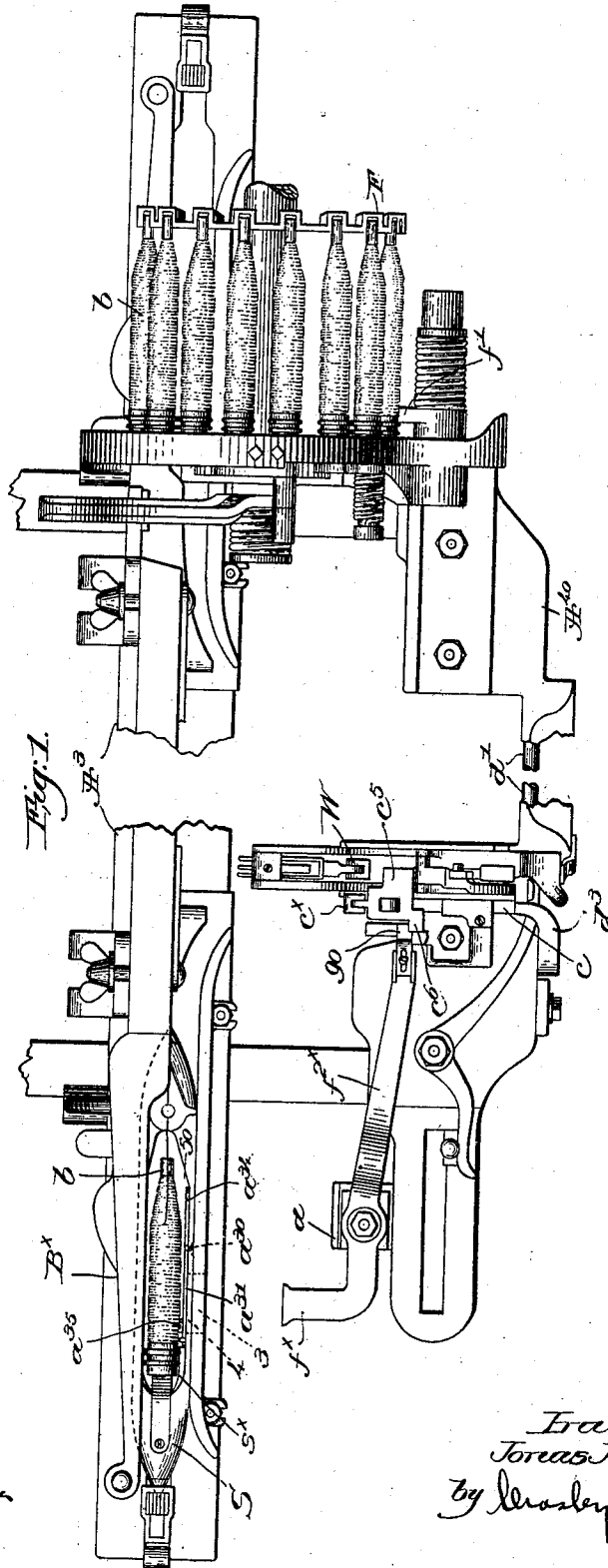

Witnesses,  
Edward F. Allen.  
Adolph H. T. Aise

Inventor;  
J. Northrop,  
by Wesley Gregory,  
attys.

No. 682,563.

Patented Sept. 10, 1901.

J. NORTHROP.  
FILLING REPLENISHING LOOM.

(Application filed Apr. 11, 1901.)

(No Model.)

2 Sheets—Sheet 2.

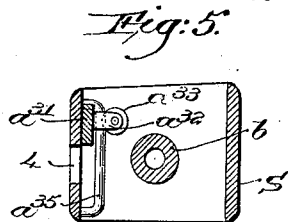
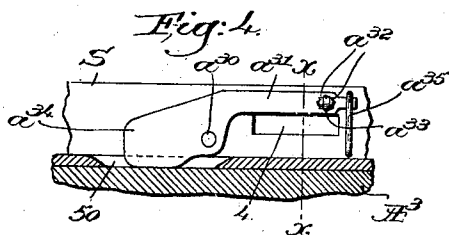
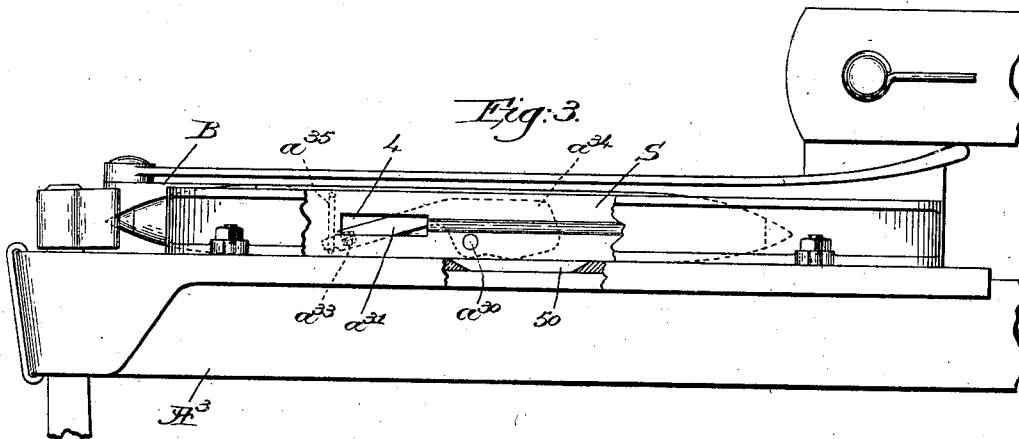
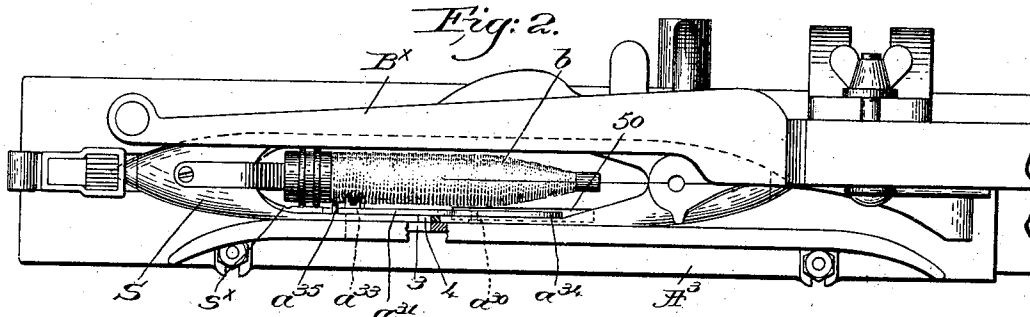

Witnesses,  
Edward G. Allen,  
Adolph H. Vain.

Inventor,  
J. Northrop,  
by Wesley Gregory,  
Att'y.

# UNITED STATES PATENT OFFICE.

JONAS NORTHROP, OF HOPEDALE, MASSACHUSETTS, ASSIGNOR TO DRAPER COMPANY, OF SAME PLACE AND PORTLAND, MAINE.

## FILLING-REPLENISHING LOOM.

SPECIFICATION forming part of Letters Patent No. 682,563, dated September 10, 1901.

Application filed April 11, 1901. Serial No. 55,372. (No model.)

*To all whom it may concern:*

Be it known that I, JONAS NORTHROP, a subject of the King of Great Britain, residing at Hopedale, in the county of Worcester and State of Massachusetts, have invented an Improvement in Filling-Replenishing Looms, of which the following description, in connection with the accompanying drawings, is a specification, like characters on the drawings representing like parts.

This invention relates to looms provided with automatic filling-replenishing mechanism, and more particularly to looms of the type wherein the change of filling is effected automatically when the filling in the shuttle has been exhausted to a predetermined extent, so that the fresh filling will be inserted in the shuttle before complete exhaustion of the old filling, the desired point of exhaustion of the filling in the shuttle being indicated by or through a feeler, which is moved at each alternate forward beat of the lay until the filling has been exhausted to the desired extent. At such time the necessary movement of the feeler does not take place and through suitable controlling means the filling-replenishing mechanism is actuated.

Figure 1 is a top or plan view, centrally broken out, of a sufficient portion of a loom to be understood, with one embodiment of my invention applied thereto. Fig. 2 is an enlarged plan of the left-hand end of the lay shown in Fig. 1, with its shuttle-box and the shuttle therein. Fig. 3 is a front elevation thereof, the front wall of the shuttle-box being partly broken out. Fig. 4 is a detail view of a portion of the side wall of the shuttle viewed from the interior of the shuttle and showing the feeler-actuator in the position assumed when a change of filling is to be effected; and Fig. 5 is a transverse sectional view of the shuttle on the line  $x x$ , Fig. 4, looking toward the right.

Referring to Fig. 1, the breast-beam  $A^{40}$ , the lay  $A^3$ , the filling-feeder  $F$  for the filling-carriers  $b$ , the transferrer  $f'$ , and the operating or controlling shaft  $d'$ , adapted to be rocked to effect a change of filling, are and may be substantially as in United States Patent No. 662,320, dated November 20, 1900. The stand  $\alpha$ , upon which is adjustably fulcrumed the

L-shaped feeler-arm  $f^x$ , having its inner end extended at  $f^{2x}$  and provided with a wear-plate 90, the shuttle-box  $B^x$ , having an aperture 3 in its front wall through which the extremity of the feeler  $f^x$  passes as the lay beats up, the weft-hammer  $W$ , the slide-bar  $c$  having fulcrumed upon it a latch-carrier  $c^5$  and the latch  $c^x$ , and the foot  $c^6$  to rest upon the plate 90 of the feeler-arm  $f^{2x}$ , and the upturned arm  $d^3$ , fast on the rock-shaft  $d'$  to rock the latter when the slide-bar  $c$  is moved outwardly, are also all as in said patent referred to, the latch  $c^x$  being normally in the path of a part of the weft-hammer to be engaged thereby to move the slide-bar  $c$  outward unless the plate 90 is withdrawn from the foot  $c^6$ . As in said patent, the feeler  $f^x$  will be intermittingly engaged and moved until the filling is exhausted to a predetermined extent, each of such movements of the feeler acting to withdraw the plate 90 from beneath the foot  $c^6$  to thereby permit the latch  $c^x$  to move into inoperative position—that is, out of the path of the weft-hammer. In the patent referred to the feeler entered the aperture 3 in the front wall of the shuttle-box and also an aperture 4 in the side wall of the shuttle  $S$  to directly engage the filling; but in my present invention I have provided a feeler-actuator which is maintained by the shuttle-filling in position to intermittingly engage and move the feeler until the filling has been exhausted to a predetermined extent, and at such time the feeler and the actuator fail to cooperate, and the actuation of the filling-replenishing mechanism is then effected by or through the feeler. In the present embodiment of my invention the shuttle  $S$ , which may be an automatically self-threading shuttle of any usual construction and provided with holding-jaws  $s^x$  for the head of the filling-carrier, is provided in one of its side walls with an aperture 4, registering with the aperture 3 in the front wall of the shuttle-box  $B^x$  when the shuttle is properly boxed therein, as shown in Figs. 1, 2, and 3, and on the inner face of the slotted side wall of the shuttle I have pivotally mounted at  $a^{30}$  the feeler-actuator, shown as a thin plate or blade-like arm  $a^{31}$ , having at or near its free end intumed ears  $a^{32}$  to support a roll

or other projection  $a^{33}$ , adapted to be engaged by the filling on the filling-carrier, as will be explained. The opposite end of the arm or actuator is enlarged, as at  $a^{34}$ , to form a species of counterbalance, the normal tendency of which is to elevate the opposite end of the arm, the swinging movement of the actuator being limited by a loop-like stop  $a^{35}$ , secured to the shuttle-wall in a substantially vertical plane, the free end of the feeler-actuator playing in the guard. The said actuator is so positioned relatively to the slot 4 that, unless the actuator is in the position shown in Fig. 4, the said slot will be closed sufficiently by the actuator to prevent the entrance of the feeler  $f^x$  into the interior of the shuttle.

The raceway of the lay in the bottom of the shuttle-box  $B^x$  is shown in Figs. 3 and 4 as provided with a recess or pocket 50 to permit the lower edge of the counterbalancing portion  $a^{34}$  to enter it if the feeler-actuator is free to move into the position shown in Fig. 4. The right-hand shuttle-box, or that one adjacent the filling-replenishing mechanism, is not provided with any pocket or recess, and when the shuttle is in that box the bottom of the shuttle-box will act upon the lower edge of the part  $a^{34}$  to lift it and depress the actuator  $a^{31}$  into the dotted-line position shown in Fig. 3 even should there be no filling in the shuttle. Now when a fresh filling-carrier is inserted in the shuttle the diameter of the filling mass thereupon will be such that the filling will engage the roll  $a^{33}$  and of itself depress the actuator to cover the slot 4 in the shuttle, and it will continue to be covered by the actuator so long as the diameter of the filling mass is sufficient to engage the roll and depress the actuator downward. When, however, the filling has been wound off to a predetermined extent, the diameter of the mass left on the filling-carrier will be so reduced that the roll will no longer be engaged, and then the greater weight of the counterbalance  $a^{34}$  will operate to lift the actuator, and when the shuttle enters the box  $B^x$  the pocket 50 will permit the counterbalance to move the feeler-actuator into position to open the slot 4. So long as the filling in the shuttle maintains the feeler-actuator in position to more or less close the slot 4 it will be manifest that on every alternate forward beat of the lay when the shuttle is in the box  $B^x$  the feeler  $f^x$  will enter the aperture 3 in the front wall of the shuttle-box and will then contact with the actuator, and a sufficient movement will be imparted to the feeler as the lay completes its forward stroke to remove the plate 90 from the foot  $c^6$ , and the latch  $c^x$  will be moved into inoperative position, as provided for in the patent hereinbefore referred to. When, however, the exhaustion of the shuttle-filling to the predetermined extent releases the feeler-actuator, as has been described, and it assumes a position, such as shown in Fig. 4, to fully open the slot 4, the feeler will

then not only enter the aperture 3, but it will also pass freely through the slot 4 into the interior of the shuttle-body, and it will not be moved, so that the plate 90 will not be withdrawn from beneath the foot  $c^6$ . The latch-carrier  $c^3$  accordingly will not be rocked on its fulcrum, and the latch  $c^x$  will remain in the path of and to cooperate with the weft-hammer  $W$ , and the slide-bar  $c$  will be moved outward against the arm  $d^3$  to rock the operating or controlling shaft  $d'$ , and in well-known manner the filling-replenishing mechanism will be operated when the shuttle reaches the right-hand shuttle-box, and a new supply will be inserted in the shuttle. The incoming or fresh supply of filling operates to eject the spent filling-carrier, the latter passing freely through the bottom of the shuttle and the usual slot in the bottom of the shuttle-box, inasmuch as no obstruction is afforded by the feeler-actuator, and the diameter of the filling mass just supplied will operate, as has been described, to maintain the feeler-actuator in position to intermittently engage and move the feeler. The roll  $a^{33}$  is preferably used to avoid any possibility of injuring the filling.

The construction is exceedingly simple, and it will be noted that by avoiding direct contact of the feeler with the yarn at every alternate beat of the lay there is no tendency to rub or abrade the filling. It also allows much greater leeway for wear and change of position of parts and greater leeway in the position of the shuttle in the box.

My invention is not restricted to the precise construction and arrangement herein shown and described, for, as far as I am aware, it is broadly new to provide a feeler-actuator, which is maintained by direct engagement with the shuttle-filling in position to intermittently engage and move the feeler until the filling has been exhausted to a predetermined extent.

Having fully described my invention, what I claim as new, and desire to secure by Letters Patent, is—

1. In a loom provided with automatic filling-replenishing mechanism, a feeler, and an actuator therefor maintained by engagement with the shuttle-filling in position to intermittently engage and move the feeler until the filling has been exhausted to a predetermined extent, failure of the feeler to cooperate with the actuator operating by or through the former to effect the actuation of the filling-replenishing mechanism.

2. In a loom provided with automatic filling-replenishing mechanism, a shuttle adapted to contain a supply of filling, a feeler, and an actuator therefor maintained by engagement with the shuttle-filling in position to intermittently engage and move the feeler until the diameter of the filling mass has been reduced to a predetermined extent, failure of the feeler to cooperate with the actuator

operating by or through the former to effect the actuation of the filling-replenishing mechanism.

3. In a loom, provided with automatic filling-replenishing mechanism, a feeler, a shuttle adapted to contain a supply of filling, and a feeler-actuator mounted on the shuttle and maintained by engagement with the filling therein in position to intermittently engage and move the feeler until the filling has been exhausted to a predetermined extent, failure of the feeler to cooperate with the actuator operating by or through the former to effect the actuation of the filling-replenishing mechanism.

4. In a loom provided with automatic filling-replenishing mechanism, a feeler, a shuttle adapted to contain a supply of filling, and a feeler-actuator pivotally mounted on the shuttle and maintained by engagement with the filling therein in position to intermittently engage and move the feeler until the filling mass has been reduced in diameter to a predetermined extent, failure of the feeler to cooperate with the actuator operating by or through the former to effect the actuation of the filling-replenishing mechanism.

5. In a loom provided with automatic filling-replenishing mechanism, a feeler, a shuttle adapted to contain a supply of filling, and having an aperture in its side wall to receive the feeler, and a feeler-actuator pivotally mounted on the shuttle and maintained by engagement with the filling therein in position to close the aperture in the shuttle and intermittently engage and move the feeler until the filling has been exhausted to a predetermined extent, opening of the aperture by withdrawal therefrom of the actuator permitting entrance of the feeler into the shuttle, to thereby effect the actuation of the filling-replenishing mechanism.

6. In a loom provided with automatic filling-replenishing mechanism, a feeler, a shuttle adapted to contain a supply of filling, and having an aperture in its side wall to receive the feeler, and an arm pivoted on the shuttle, one end of the arm being engaged by the filling until exhausted to a predetermined extent, to thereby retain the arm in position to intermittently engage and move the feeler, the arm when released by the exhaustion of the filling moving out of the feeler-path, failure of the feeler to be moved effecting the actuation of the filling-replenishing mechanism.

7. In a loom provided with automatic filling-replenishing mechanism, a feeler, a shuttle adapted to contain a supply of filling, and having an aperture in its side wall to receive the feeler, and a plate-like actuator pivotally mounted on the inner face of the side wall of the shuttle adjacent the aperture, said actuator having an upturned projection to be engaged by the filling until exhausted to a predetermined extent, retaining the actuator in position to intermittently engage and move

the feeler, the actuator when its toe is released moving out of the feeler-path and permitting passage of the feeler through the aperture, non-cooperation of the actuator and feeler operating through the latter to effect actuation of the filling-replenishing mechanism.

8. In a loom provided with automatic filling-replenishing mechanism, a feeler, a shuttle adapted to contain a supply of filling, and a feeler-actuator pivotally mounted on the shuttle and having a roll to engage the filling, the latter maintaining the actuator in position to intermittently engage and move the feeler until the filling has been exhausted to a predetermined extent, failure of the feeler to cooperate with the actuator operating by or through the former to effect the actuation of the filling-replenishing mechanism.

9. In a loom provided with automatic filling-replenishing mechanism, a feeler, a shuttle adapted to contain a supply of filling, a feeler-actuator pivotally mounted on the shuttle and having a roll to engage the filling, and means to limit the pivotal movement of the actuator, the latter being maintained by the filling in position to intermittently engage and move the feeler until the filling has been exhausted to a predetermined extent, failure of the feeler to cooperate with the actuator operating by or through the former to effect the actuation of the filling-replenishing mechanism.

10. In a loom provided with automatic filling-replenishing mechanism, the lay having a recess in the bottom of one of its shuttle-boxes, a shuttle adapted to contain a supply of filling, a feeler-actuator pivotally mounted on the shuttle and maintained in operative position by the filling in the shuttle until the volume thereof has been exhausted to a predetermined extent, and means to control the time of operation of the filling-replenishing mechanism, said means including a feeler to intermittently engage and be moved by the actuator when the latter is in operative position, failure of cooperation of the feeler and its actuator acting through the controlling means to effect a change of filling, the recess in the lay permitting a part of the actuator to enter it when the filling has been exhausted as described.

11. An automatically self-threading shuttle for feeler-loom, adapted to have a filling-supply inserted automatically therein, and having an aperture in one of its side walls, a feeler-actuator movably mounted on the shuttle and adapted to close or open the aperture, and means to move the actuator to open the aperture by or through exhaustion of the filling to a predetermined extent.

12. An automatically self-threading shuttle for feeler-loom, adapted to automatically receive and to contain a supply of filling and having an aperture in one of its side walls, a feeler-actuator movably mounted on the shuttle and having a filling-engaging portion, to automatically move the actuator into position to close the aperture by insertion of the

filling into the shuttle, and means to move the actuator to open the slot when the actuator is released by exhaustion of the filling to a predetermined extent.

5 13. An automatically self-threading shuttle for feeler-looms, having an aperture in one of its side walls, a feeler-actuator pivotally mounted on the shuttle and adapted to close or open the aperture, and a counter-  
10 balance to automatically move the actuator to open the aperture, by or through exhaustion of the filling to a predetermined extent.

14. An automatically self-threading shuttle for feeler-looms, having an aperture in one  
15 of its side walls, a feeler-actuator pivotally mounted on the shuttle and located wholly within it and adapted to close or open the aperture, means to automatically move the actuator to open the aperture by or through the in-  
20 sertion of a supply of filling, and means to limit the pivotal movement of the actuator.

15. In a loom provided with automatic filling-replenishing mechanism, a shuttle provided with an actuator continuously and automatically governed in movement by the  
25 volume of yarn in the shuttle and in direct engagement with the yarn until the volume thereof is reduced to a predetermined extent, and intermediate devices between said actuator and the filling-supplying mechanism to  
30 operate the latter through the movement of the actuator and intermediate devices on exhaustion of the filling to a predetermined point.

In testimony whereof I have signed my  
35 name to this specification in the presence of two subscribing witnesses.

JONAS NORTHROP.

Witnesses:

GEORGE OTIS DRAPER,  
ERNEST W. WOOD.