



(22) Date de dépôt/Filing Date: 2007/02/23
(41) Mise à la disp. pub./Open to Public Insp.: 2007/11/08
(62) Demande originale/Original Application: 2 648 024
(30) Priorité/Priority: 2006/04/03 (US60/788,795)

(51) Cl.Int./Int.Cl. *E21B 43/04* (2006.01),
E21B 43/08 (2006.01)
(71) Demandeur/Applicant:
EXXONMOBIL UPSTREAM RESEARCH COMPANY,
US
(72) Inventeurs/Inventors:
HAEBERLE, DAVID C., US;
YEH, CHARLES, US;
BENISH, TIM G., US;
BARRY, MICHAEL D., US;
HECKER, MICHAEL T., US;
BLACKLOCK, JON, US
(74) Agent: BORDEN LADNER GERVAIS LLP

(54) Titre : PROCÉDE ET APPAREIL DE BLOCAGE DU SABLE ET DE REGULATION DU DEBIT D'ENTREE AU
COURS D'OPERATIONS REALISEES DANS UN Puits DE FORAGE
(54) Title: WELLBORE METHOD AND APPARATUS FOR SAND AND INFLOW CONTROL DURING WELL
OPERATIONS

(57) **Abrégé/Abstract:**

A sand control device comprising a first tubular member, a second tubular member disposed within the first tubular member, and a barrier element therebetween. The barrier element isolates a first chamber from a second chamber formed between the first and second tubular members. The device also includes a conduit, which provides a fluid flow path between the first and the second chambers. The conduit provides adequate leak-off during gravel packing operations and sufficient choking during production operations. The device also includes a shunt tube secured to at least one of the first and second tubular members and passes through the barrier element. The method comprises disposing the sand control device within a wellbore, gravel packing the sand control device using a non-Newtonian fluid, and producing hydrocarbons through the conduit in the sand control device.



ABSTRACT

A sand control device comprising a first tubular member, a second tubular member disposed within the first tubular member, and a barrier element therebetween. The barrier element isolates a first chamber from a second chamber formed between the first and second tubular members. The device also includes a conduit, which provides a fluid flow path between the first and the second chambers. The conduit provides adequate leak-off during gravel packing operations and sufficient choking during production operations. The device also includes a shunt tube secured to at least one of the first and second tubular members and passes through the barrier element. The method comprises disposing the sand control device within a wellbore, gravel packing the sand control device using a non-Newtonian fluid, and producing hydrocarbons through the conduit in the sand control device.

WELLBORE METHOD AND APPARATUS FOR SAND AND INFLOW CONTROL DURING WELL OPERATIONS

[0001] This application is a divisional application of Canadian application Serial No. 2,648,024 filed February 23, 2007.

FIELD OF THE INVENTION

[0002] This invention relates generally to an apparatus and method for use in wellbores and associated with the production of hydrocarbons. More particularly, this invention relates to a wellbore apparatus and method for providing flow control that may be utilized to enhance at least gravel packing and production operations for a well.

BACKGROUND

[0003] This section is intended to introduce various aspects of the art, which may be associated with exemplary embodiments of the present invention. This discussion is believed to assist in providing a framework to facilitate a better understanding of particular aspects of the present invention. Accordingly, it should be understood that this section should be read in this light, and not necessarily as admissions of prior art.

[0004] The production of hydrocarbons, such as oil and gas, has been performed for numerous years. However, when producing hydrocarbons from subsurface or subsurface formations, it becomes more challenging because of the location of certain subsurface formations. For example, some subsurface formations are located in ultra-deep water, at depths that extend the reach of drilling operations, in high pressure/temperature reservoirs, in long intervals, at high production rate, and at remote locations. As such, the location of the subsurface formation may present problems that increase the individual well cost dramatically. That is, the cost of accessing the subsurface formation may result in fewer wells being completed because of the economics of the field. Accordingly, well reliability and longevity

- 2 -

become design considerations to avoid undesired production loss and expensive intervention or workovers for these wells.

[0005] To enhance hydrocarbon production, a production system may utilize various devices, such as sand control devices and other tools, for specific tasks within a well. Typically, these devices are placed into a wellbore completed in either a cased-hole or open-hole completion. In a cased-hole completion, a casing string is placed in the wellbore and perforations are made through the casing string into subsurface formations to provide a flow path for formation fluids, such as hydrocarbons, into the wellbore. Alternatively, in an open-hole completion, a production string is positioned inside the wellbore without a casing string. The formation fluids flow through the annulus between the subsurface formation and the production string to enter the production string.

[0006] Regardless of the completion type, sand control devices are typically utilized within a well to manage the production of solid material, such as sand. The production of solid material may result in sand production at surface, downhole equipment damage, reduced well productivity and/or loss of the well. The sand control device, which may have slotted openings or may be wrapped by a screen, may also be utilized with a gravel pack in certain environments. Gravel packing a well involves placing gravel or other particulate matter around a sand control device. In an open-hole completion, a gravel pack is typically positioned between the wall of the wellbore and a sand screen that surrounds a perforated base pipe. Alternatively, in a cased-hole completion, a gravel pack is positioned between a casing string having perforations and a sand screen that surrounds a perforated base pipe. Regardless, the formation fluids flow from the subsurface formation into the production tubing string through the gravel pack and sand control device, while solids above a certain size are blocked.

[0007] As an enhancement to the gravel packing process, alternative technologies may also be utilized to form substantially complete gravel packs within the wellbore. For example, the alternate flow paths, such as internal or external shunt tubes, may be utilized to bypass sand bridges and distribute the gravel evenly through the intervals. For further details, alternate flow paths are described further in

U.S. Pat. Nos. 4,945,991; 5,082,052; 5,113,935; 5,333,688 and Intl. Patent Appl. No. PCT/US04/01599;

[0008] In addition to preventing solids production, the flow of the formation fluids may also be controlled within a well. For instance, sand control devices may include technology to regulate flow downhole, such as inflow control technology or inflow control devices (ICDs). See, e.g., Reslink's RESFLOW™, Baker's EQUALIZER™, or Weatherford's FLOREG™. These devices are typically used in long, horizontal, open-hole completions to balance inflow into the completion across production intervals or zones. The balanced inflow enhances reservoir management and reduces the risk of early water or gas breakthrough from a high permeability reservoir streak or the heel of a well. Additionally, more hydrocarbons may be captured from the toe of the well through the application of the inflow control technology.

[0009] Because gravel packing operations generally involve passing large quantities of fluid, such as carrier fluid, through the sand screen and the ICD, gravel packing with typical ICDs is not feasible because the gravel packing and production operations use the same flow paths. In particular, localized and reduced inflow of the carrier fluid due to ICDs may cause early bridging, loose packs, voids, and/or increased pressure requirements during gravel pack pumping. Accordingly, the need exists for method and apparatus that provides inflow control without limiting the formation of a gravel pack.

[0010] Other related material may be found in at least U.S. Patent No. 5,293,935; U.S. Patent No. 5,435,393; U.S. Patent No. 5,642,781; U.S. Patent No. 5,803,179; U.S. Patent No. 5,896,928; U.S. Patent No. 6,112,815; U.S. Patent No. 6,112,817; U.S. Patent No. 6,237,683; U.S. Patent No. 6,302,216; U.S. Patent No. 6,308,783; U.S. Patent No. 6,405,800; U.S. Patent No. 6,464,261; U.S. Patent No. 6,533,038; U.S. Patent No. 6,622,794; U.S. Patent No. 6,644,412; U.S. Patent No. 6,715,558; U.S. Patent No. 6,745,843; U.S. Patent No. 6,749,024; U.S. Patent No. 6,786,285; U.S. Patent No. 6,817,416; U.S. Patent No. 6,851,560; U.S. Patent No. 6,857,475; U.S. Patent No. 6,875,476; U.S. Patent No. 6,860,330; U.S. Patent No. 6,868,910; U.S. Patent No. 6,883,613; U.S. Patent No. 6,886,634; U.S. Patent No. 6,892,816; U.S. Patent No. 6,899,176; U.S. Patent No. 6,978,840; U.S. Patent

Application Publication No. 2003/0173075; U.S. Patent Application Publication No. 2004/0251020; U.S. Patent Application Publication No. 2004/0262011; U.S. Patent Application Publication No. 2005/0263287; U.S. Patent Application Publication No. 2006/0042795; U.S. Patent App. No. 60/765,023; and U.S. Patent App. No. 60/775,434.

SUMMARY

[0011] In one embodiment, a system associated with production of hydrocarbons is described. The system includes a wellbore utilized to produce hydrocarbons from a subsurface reservoir; a production tubing string disposed within the wellbore; and at least one sand control device coupled to the production tubing string and disposed within the wellbore. At least one of the at least one sand control device includes a first tubular member having a permeable section and a non permeable section; a second tubular member disposed within the first tubular member, wherein the second tubular member has a plurality of openings and at least one inflow control device that each provide a flow path to the interior of the second tubular member; and a sealing mechanism disposed between the first tubular member and the second tubular member, wherein the sealing mechanism is configured to provide pressure loss during gravel packing operations that is less than the pressure loss during at least a portion of production operations.

[0012] In a second embodiment, a method of producing hydrocarbons from a well is described. The method includes disposing at least one sand control device within a wellbore adjacent to a subsurface formation, wherein at least one of the at least one sand control device comprises a first tubular member having a permeable section and a non permeable section; a second tubular member disposed within the first tubular member, wherein the second tubular member has a plurality of openings and at least one inflow control device that each provide a flow path to the interior of the second tubular member; and a sealing mechanism disposed between the first tubular member and the second tubular member, wherein the sealing mechanism is configured to provide pressure loss during gravel packing operations that is less than the pressure loss during at least a portion of production operations; gravel packing the at least one sand control device within the wellbore; and producing hydrocarbons

- 5 -

from the at least one sand control device by passing hydrocarbons through the at least one sand control device.

[0013] In a third embodiment, another system associated with production of hydrocarbons is described. This system includes a production tubing string disposed within a wellbore utilized to access a subsurface formation; at least one sand control device coupled to the production tubing string and disposed within the wellbore. At least one of the at least one sand control device includes a first tubular member having a permeable section and a non permeable section; a second tubular member disposed within the first tubular member, wherein the second tubular member has a plurality of openings and at least one inflow control device; and a sealing mechanism disposed between the first tubular member and the second tubular member. The sealing mechanism configured to provide a first flow path into the interior of the second tubular member during gravel packing operations through one of only the plurality of openings and the plurality of openings along with the at least one inflow control device and provide a second flow path into the interior of the second tubular member during a portion of production operations through only the at least one inflow control device.

[0014] In a fourth embodiment, another method associated with production of hydrocarbons is described. The method includes providing a sand control device having a first tubular member with a permeable section and a non permeable section; a second tubular member disposed within the first tubular member, wherein the second tubular member has a plurality of openings and at least one inflow control device; and a sealing mechanism disposed between the first tubular member and the second tubular member, wherein the sealing mechanism is configured to provide a first flow path to the interior of the second tubular member during gravel packing operations through one of only the plurality of openings and the plurality of openings along with the at least one inflow control device; and provide a second flow path to the interior of the second tubular member during at least a portion of production operations through only the at least one inflow control device; disposing the sand control device within a wellbore; engaging the sand control device to a crossover tool to form a gravel pack at least partially around the sand control device; disengaging the crossover tool from the sand control device; and coupling the sand control device

- 6 -

to a production tubing string to produce hydrocarbons through the at least one inflow control device.

[0015] In a fifth embodiment, an apparatus for producing hydrocarbons is described. The apparatus includes a first tubular member having a permeable section and a non permeable section; a second tubular member disposed within the first tubular member, wherein the second tubular member has a plurality of openings and at least one inflow control device; and a sealing element disposed between the first tubular member and the second tubular member and disposed between the plurality of openings and at least one inflow control device. The sealing element is configured to provide a first flow path into the interior of the second tubular member from the permeable section of the first tubular member through the plurality of openings and a second flow path into the interior of the second tubular member from the permeable section of the first tubular member through the at least one inflow control device during a first operation; and block fluid flow through the first flow path during a second operation.

[0016] In a sixth embodiment, a second apparatus for producing hydrocarbons is described. The apparatus includes a first tubular member having a permeable section and a non permeable section; a second tubular member disposed within the first tubular member, wherein the second tubular member has a plurality of openings that provide a fluid flow path into the interior of the second tubular member; and a barrier element disposed between the first tubular member and the second tubular member. The barrier element being configured to isolate a first chamber from a second chamber formed between the first tubular member and second tubular member, wherein the first chamber includes the permeable section of the first tubular member and the second chamber includes the plurality of openings in the second tubular member; and at least one conduit disposed between the first tubular member and second tubular member, wherein the at least one conduit provides at least one fluid flow path between the first chamber and the second chamber through the barrier element.

[0017] In a seventh embodiment, a third apparatus for producing hydrocarbons is described. The apparatus includes a first tubular member having a permeable section and a non permeable section; a second tubular member disposed within the

- 7 -

first tubular member, wherein the second tubular member has a plurality of openings and at least one inflow control device; and a sleeve disposed adjacent to the second tubular member and configured to move between a plurality of positions. The plurality of positions include a first position providing a first flow path into the interior of the second tubular member from the permeable section of the first tubular member through at least the plurality of openings; and a second position providing a second flow path into the interior of the second tubular member from the permeable section of the first tubular member through the at least one inflow control device, wherein fluid flow is prevented through the plurality of openings.

BRIEF DESCRIPTION OF THE DRAWINGS

[0018] The foregoing and other advantages of the present invention may become apparent upon reviewing the following detailed description and drawings of non-limiting examples of embodiments in which:

[0019] FIG. 1 is an exemplary production system in accordance with certain aspects of the present invention;

[0020] FIG. 2 is an exemplary flow chart of well operations involving a sand control device with an inflow control mechanism in FIG. 1 in accordance with aspects of the present invention;

[0021] FIGs. 3A-3G are illustrative views of an embodiment of a sand control device utilized in the production system of FIG. 1 with an inflow control mechanism having a sealing element in accordance with aspects of the present invention;

[0022] FIGs. 4A-4G are illustrative views of a first alternative embodiment of the sand control device of FIGs. 3A-3G in accordance with aspects of the present invention;

[0023] FIGs. 5A-5F are illustrative views of a second alternative embodiment of the sand control device of FIGs. 3A-3G in accordance with aspects of the present invention;

- 8 -

[0024] FIGs. 6A-6G are illustrative views of a third alternative embodiment of the sand control device of FIGs. 3A-3G in accordance with aspects of the present invention;

[0025] FIGs. 7A-7B are illustrative views of another alternative embodiment of a sand control device utilized in the production system of FIG. 1 with an inflow control mechanism having a sealing element in accordance with aspects of the present invention;

[0026] FIGs. 8A-8C are illustrative views of an embodiment of a sand control device utilized in the production system of FIG. 1 with an inflow control mechanism having a conduit in accordance with aspects of the present invention;

[0027] FIGs. 9A-9E are illustrative views of a first alternative embodiment of sand control device of FIGs. 8A-8C in accordance with aspects of the present invention;

[0028] FIGs. 10A-10C are illustrative views of a second alternative embodiment of sand control device of FIGs. 8A-8C in accordance with aspects of the present invention;

[0029] FIGs. 11A-11F are illustrative views of yet another alternative embodiment of a sand control device utilized in the production system of FIG. 1 with an inflow control mechanism having a sleeve in accordance with aspects of the present invention; and

[0030] FIG. 12 is an alternative exemplary production system in accordance with aspects of the present invention.

DETAILED DESCRIPTION

[0031] In the following detailed description section, the specific embodiments of the present invention are described in connection with preferred embodiments. However, to the extent that the following description is specific to a particular embodiment or a particular use of the present invention, this is intended to be for exemplary purposes only and simply provides a description of the exemplary embodiments. Accordingly, the invention is not limited to the specific embodiments

- 9 -

described below, but rather, it includes all alternatives, modifications, and equivalents falling within the true spirit and scope of the appended claims.

[0032] The present invention includes one or more embodiments of sand control devices that may be utilized in a completion, production, or injection system to enhance well operations, which may include gravel packing operations and production operations, which are described below. Under the present invention, an apparatus, system and method are described for running and gravel packing a sand control device having an inflow control mechanism in a well completion, such as an open-hole or cased-hole completion. Then, the sand control device is utilized to produce formation fluids, such as hydrocarbons, from the well completion. The embodiments of the sand control device may include a sand control device with a sealing mechanism, such as a swellable material, sealing element or adjustable sleeve. Accordingly, the specific embodiments of the sand control device may include a sand control device with a sealing element, at least one conduit, and/or at least one sleeve to provide flexibility in the well operations. In this embodiment, the sealing mechanism is configured to provide pressure loss during certain operations, such as gravel packing operations, that is less than the pressure loss during other operations, such as production operations. The pressure loss is change in fluid pressure as the fluid flows outside the sand control device into the interior of the base pipe or primary tubular member. The pressure loss may include frictional pressure loss and form loss. The higher pressure loss results in increased inflow control, which provides flexibility in providing the desired fluid flow control for the different operations. As such, the present invention may be used in well completions to enhance gravel placement, hydrocarbon production and/or stimulation of a subsurface formation. Note that in a well completion, the sand control devices of the present invention may be used in combination with other sand control devices.

[0033] Turning now to the drawings, and referring initially to FIG. 1, an exemplary production system **100** in accordance with certain aspects of the present invention is illustrated. In the exemplary production system **100**, a floating production facility **102** is coupled to a subsea tree **104** located on the sea floor **106**. Through this subsea tree **104**, the floating production facility **102** accesses one or more subsurface formations, such as subsurface formation **107**, which may include multiple production intervals or zones **108a-108n**, wherein number "n" is any integer

- 10 -

number. The production intervals **108a-108n** may have hydrocarbons, such as oil and gas. Beneficially, devices, such as sand control devices **138a-138n** having inflow control mechanisms, may be utilized to enhance the production of hydrocarbons from the production intervals **108a-108n**. However, it should be noted that the production system **100** is illustrated for exemplary purposes and the present invention may be useful in the production or injection of fluids from any subsea, platform or land location.

[0034] The floating production facility **102** may be configured to monitor and produce hydrocarbons from the production intervals **108a-108n** of the subsurface formation **107**. The floating production facility **102** may be a floating vessel capable of managing the production of fluids, such as hydrocarbons, from subsea wells. These fluids may be stored on the floating production facility **102** and/or provided to tankers (not shown). To access the production intervals **108a-108n**, the floating production facility **102** is coupled to a subsea tree **104** and control valve **110** via a control umbilical **112**. The control umbilical **112** may include production tubing for providing hydrocarbons from the subsea tree **104** to the floating production facility **102**, control tubing for hydraulic or electrical devices, and a control cable for communicating with other devices within the wellbore **114**.

[0035] To access the production intervals **108a-108n**, the wellbore **114** penetrates the sea floor **106** to a depth that interfaces with the production intervals **108a-108n** at different depths within the wellbore **114**. As may be appreciated, the production intervals **108a-108n**, which may be referred to as production intervals **108**, may include various layers or intervals of rock that may or may not include hydrocarbons and may be referred to as zones. The subsea tree **104**, which is positioned over the wellbore **114** at the sea floor **106**, provides an interface between devices within the wellbore **114** and the floating production facility **102**. Accordingly, the subsea tree **104** may be coupled to a production tubing string **128** to provide fluid flow paths and a control cable (not shown) to provide communication paths, which may interface with the control umbilical **112** at the subsea tree **104**.

[0036] Within the wellbore **114**, the production system **100** may also include different equipment to provide access to the production intervals **108a-108n**. For

- 11 -

instance, a surface casing string **124** may be installed from the sea floor **106** to a location at a specific depth beneath the sea floor **106**. Within the surface casing string **124**, an intermediate or production casing string **126**, which may extend down to a depth near the production interval **108a**, may be utilized to provide support for walls of the wellbore **114**. The surface and production casing strings **124** and **126** may be cemented into a fixed position within the wellbore **114** to further stabilize the wellbore **114**. Within the surface and production casing strings **124** and **126**, a production tubing string **128** may be utilized to provide a flow path through the wellbore **114** for hydrocarbons and other fluids. A subsurface safety valve **132** may be utilized to block the flow of fluids from portions of the production tubing string **128** in the event of rupture or break above the subsurface safety valve **132**. Further, packers **134** and **136** may be utilized to isolate specific zones within the wellbore annulus from each other. The packers **134** and **136** may be configured to provide fluid communication paths between surface and the sand control devices **138a-138n**, while preventing fluid flow in one or more other areas, such as a wellbore annulus.

[0037] In addition to the above equipment, other equipment, such as sand control devices **138a-138n** and gravel packs **140a-140n**, may be utilized to manage the flow of fluids from within the wellbore. In particular, the sand control devices **138a-138n** may be utilized to manage the flow of fluids and/or particles into the production tubing string **128** with gravel packs **140a-140n**. The sand control devices **138a-138n** may include slotted liners, stand-alone screens (SAS); pre-packed screens; wire-wrapped screens, membrane screens, expandable screens and/or wire-mesh screens, while the gravel packs **140a-140n** may include gravel or other suitable solid material. The sand control devices **138a-138n** may also include inflow control mechanisms, such as inflow control devices (i.e. valves, conduits, nozzles, or any other suitable mechanisms), which may increase pressure loss along the fluid flow path. The gravel packs **140a-140n** may be complete gravel packs that cover all of the respective sand control devices **138a-138n**, or may be partially disposed around sand control devices **138a-138n**. Regardless, the sand control devices **138a-138n** may include different components that provide flow control for the intervals **108a-108n** of the well. The process of installing and using these sand control devices is shown below in FIG. 2.

- 12 -

[0038] FIG. 2 is an exemplary flow chart of the installation and use of the sand control devices of FIG. 1 in accordance with aspects of the present invention. This flow chart, which is referred to by reference numeral 200, may be best understood by concurrently viewing FIG. 1. In this flow chart 200, a process to enhance the production of hydrocarbons from a wellbore 114 by providing flow control in a sand control device along with gravel packs is described. That is, the present technique provides a mechanism for efficiently forming a gravel pack around a sand control device and providing flow control for fluids produced from the intervals once the gravel pack is formed. Accordingly, the sand control device may enhance operations and production of hydrocarbons from intervals 108 of the subsurface formation 107.

[0039] The flow chart begins at block 202. At block 204, a well may be drilled. The well may be drilled to a specific depth location through various production intervals 108 of the subsurface formation 107. The drilling of the well may involve drilling operations and typical techniques utilized for the specific fields. Then, gravel packing operations may be performed in blocks 206 and 208. The gravel packing operations include installing one or more sand control devices having an inflow control mechanism into the well, as shown in block 206. The sand control devices may include various embodiments, such as sand control device having a inflow control mechanism with a sealing element (shown in FIGs. 3A-3G, 4A-4G, 5A-5F, 6A-6G and 7A-7B), sand control device having an inflow control mechanism being conduits (shown in FIGs. 8A-8C, 9A-9E and 10A-10C), and sand control device having an inflow control mechanism with a sleeve (shown in FIGs. 11A-11F). Each of these embodiments may be installed using various techniques, such as by a drilling string, wireline, and coil tubing, and other similar techniques known to those skilled in the art. At block 208, a gravel pack may be installed within the wellbore around the sand control device. The installation of the gravel pack may include coupling a crossover tool to the sand control device and pumping carrier fluid with gravel through the crossover tool. Through the engagement between the sand control device and the crossover tool, a gravel pack may be formed at least partially around the sand control device. A specific process for forming the gravel pack is discussed further in U.S. Provisional Application No. 60/778,434. However, it should be noted that gravel packing operations may include other alternate path gravel packing or alpha beta gravel packing techniques and procedures, as well.

- 13 -

[0040] Once the gravel packing operations are complete, production operations may be performed in blocks **210-220**. With the sand control device and gravel pack installed, the sand control device may be adjusted into a production configuration, as shown in block **210**. This adjustment may include removing a washpipe, sending a signal via electrical cable or hydraulics to activate a sleeve, chemical activation or other suitable techniques to adjust the sand control device for production operations. In particular, it should be noted that the adjustment to the sand control device may be activated automatically by the presence of a stimulus, which is discussed further below. At block **212**, hydrocarbons, such as oil and gas, may be produced from the well. The production of hydrocarbons may include disengaging the crossover tool from the sand control device and coupling the sand control device to a production tubing string to produce hydrocarbons through at least one of the inflow control devices. During production, the performance of the well may be monitored, as shown in block **214**. The monitoring of the well may include general surveillance, such as monitoring the hydrocarbon production rate, water cut, gas to oil ratio, production profile from production logging, sand production and/or other similar techniques. Also, the monitoring may include detectors and sensors that determine the levels of sand production, down hole pressure, downhole temperature profiles and the like. At block **216**, a determination is made whether to shutoff fluid flow into the sand control device. This determination may include comparing the production from a certain interval to a predetermined threshold, or indication from a monitor within the wellbore that excessive water production is from a certain interval, such as a toe interval. If the interval does not need to be shutoff, the well monitoring may continue in block **214**.

[0041] However, if the interval is shutoff, a determination is made whether the production operations are to continue, as shown in block **218**. If the production operations are to continue, a maintenance operation may be performed in block **220**. The maintenance operation may include activating a mechanism within the inflow control device, such as a sleeve or valve, to prevent fluid flow into the sand control device; installing a straddle bridge across the specific interval; treating the interval with a treatment fluid and/or installing a plug within or upstream of the sand control device. Then, monitoring of the well continues in block **214**. Regardless, if the well production is complete, then the process may end at block **222**.

- 14 -

[0042] Beneficially, the use of the sand control device provides a mechanism for enhancing gravel packing operations and flexibility in the production operations, such as maintenance operations. The sand control device provides a mechanism for gravel packing a well with various perforations that may or may not be utilized in the production of hydrocarbons. Also, the sand control device may be shutoff to prevent formation fluids from entering the wellbore from a specific interval to manage specific portions of the wellbore. That is, the sand control devices provide flexibility in isolating and managing the flow from various intervals from unwanted gas or water production. These sand control devices also provide flexibility for installations to regulate flow between formations of varying pressure, productivity or permeability. For instance, the same type of sand control device may be used within a well with one interval being gravel packed and others are not gravel packed. That is, the sand control device may be utilized to gravel pack specific intervals, while other intervals are not gravel packed as part of the same process. Further, by providing balanced inflow, the sand control devices may limit annular flow to prevent hot-spots in the completion at a location of high inflow, which is typically at the heel of the completion or at an external isolation packer. Hot-spots are locations of high velocity flow where erosion is likely if sand particles or fines are in the flow stream.

[0043] For exemplary purposes, various sand control devices 138a-138n are herein described in various embodiments below. In these embodiments, a sealing mechanism may include a sealing element, a barrier element, and/or sleeve in the respective embodiments. Also, the inflow control mechanism may include a conduit or inflow control devices (i.e. small orifice or choke) in the respective embodiments. Accordingly, the specific features of each of the embodiments is discussed in the FIGs. 3A-3G, 4A-4G, 5A-5F, 6A-6G, 7A-7C, 8A-8C, 9A-9F, 10A-10F, 11A-11F and 12.

Sand Control Device with Sealing Element

[0044] FIGs. 3A-3G are illustrative views of an embodiment of a sand control device utilized in the production system of FIG. 1 having an inflow control mechanism in accordance with aspects of the present invention. Each of the sand control devices 300a and 300b include a tubular member or base pipe 302 surrounded by a sand screen 304 having ribs 305. The sand screen 304 may include a permeable section, such as a wire-wrapped screen or filter medium, and a

- 15 -

non-permeable section, such as a section of blank pipe. The ribs 305, which are not shown in FIGs. 3A and 3F for simplicity, are utilized to keep the sand screen 304 a specific distance from the base pipe 302. The space between the base pipe 302 and sand screen 304 form a chamber that is accessible from the fluids external to the sand control device 300a and 300b via the permeable section. In FIGs. 3A-3G, the sand control devices 300a and 300b, which may collectively be referred to as sand control device 300, are the same embodiment of a sand control device in different stages of operation, such as during gravel packing and production operations. Beneficially, in the sand control device 300, a sealing element 312 is configured to provide one or more flow paths to the openings 310 and/or inflow control device 308 during gravel packing operations and to block the flow path to the openings 310 prior to or during production operations. As such, the sand control device 300 may be utilized to enhance operations within the well.

[0045] In FIGs. 3A-3G, the sand control devices 300a and 300b, which may collectively be referred to as sand control device 300, may include various components utilized to manage the flow of fluids and solids into a well. For instance, the sand control device 300 includes a main body section 320, an inflow section 322, a first connection section 324, a perforated section 326 and a second connection section 328, which may be made of steel, metal alloys, or other suitable materials. The main body section 320 may be a portion of the base pipe 302 surrounded by a portion of the sand screen 304. The main body section 320 may be configured to be a specific length, such as between 10 and 50 feet (ft) (with certain sections being 6ft, 8 ft, 14 ft, 38, or 40 ft) having specific internal and outer diameters. The inflow section 322 and perforated section 326 may be other portions of the base pipe 302 surrounded by other portions of the sand screen 304, such non-permeable sections, which may include components that provide flow paths through the base pipe 302. The inflow section 322 and perforated section 326 may be configured to be between 0.5 ft and 4 ft in length. The first and second connection sections 324 and 328 may be utilized to couple the sand control device 300 to other sand control devices or piping, and may be the location of the chamber formed by the base pipe 302 and sand screen 304 ends. The first and second connection sections 324 and 328 may be configured to be a specific length, such as 2 inches (in) to 4 ft or other suitable distance, having specific internal and outer diameters.

- 16 -

[0046] In some embodiments of the present invention within the first and second connection sections 324 and 328, coupling mechanisms may be utilized to form the secure and sealed connections. For instance, a first connection 330 may be positioned within the first connection section 324, and a second connection 332 may be positioned within the second connection section 328. These connections 330 and 332 may include various methods for forming connections with other devices. For example, the first connection 330 may have internal threads and the second connection 332 may have external threads that form a seal with other sand control devices or another pipe segment. It should also be noted that in other embodiments, the coupling mechanism for the sand control device 300 may include connecting mechanisms as described in U.S. Patent No. 6,464,261; U.S. Patent No. 60/775,434; Intl. Patent Application No. WO2004/046504; Intl. Patent Application No. WO2004/094769; Intl. Patent Application No. WO2005/031105; U.S. Patent Application Pub. No. 2004/0140089; U.S. Patent Application Pub. No. 2005/0028977; U.S. Patent Application Pub. No. 2005/0061501; U.S. Patent Application Pub. No. 2005/0082060; U.S. Patent App. No. 60/765,023; and U.S. Patent App. No. 60/775,434, for example.

[0047] In some embodiments of the present invention within the inflow section 322 and perforated section 326, flow control mechanisms may be utilized to regulate flow paths or pressure loss within the sand control device. As a specific example, the sand control device 300 may include one or more inflow control devices 308, one or more perforations or openings 310, and a sealing element 312. The inflow control devices 308 may be positioned at one end of the sand control device 300 and openings 310 along with the sealing element 312 at the other end of the sand control device 300. Inflow control devices 308 may be utilized to control the flow of formation fluids from the chamber into the base pipe 302 during gravel packing and/or production operations. The inflow control devices 308 may include nozzles, valves, tortuous paths, shaped objects or other suitable mechanisms known in the art to create a pressure drop or pressure loss. In particular, the inflow control devices 308 may choke flow through form pressure loss (e.g. a shaped object, nozzle) or frictional pressure loss (e.g. helical geometry/tubes).

- 17 -

[0048] Form pressure loss, which is based on the shape and alignment of an object relative to fluid flow, is caused by separation of fluid that is flowing over an object, which results in turbulent pockets at different pressure behind the object. The openings **310** may be utilized to provide additional flow paths for the fluids, such as carrier fluids, during gravel packing operations because the inflow control devices **308** may restrict the placement of gravel by hindering the flow of carrier fluid into the base pipe **302** during gravel packing operations. The number of openings in the base pipe **302** may be selected to provide adequate inflow during the gravel packing operations to achieve partial or substantially complete gravel pack. That is, the number and size of the openings in the base pipe **302** may be selected to provide sufficient fluid flow from the wellbore through the sand screen **304**, which is utilized to deposit gravel in the wellbore and form the gravel pack. As known in the art, alternate path gravel packing techniques with proper fluid leak-off through the sand screen **304** has been demonstrated in the field to achieve a complete gravel pack.

[0049] In some embodiments of the present invention the sealing or expansion element **312** may surround the base pipe **302** and may be a hydraulically actuated inflatable element (i.e. an elastomer or thermoplastic material) or a swellable material (i.e. a swelling rubber element or swellable polymer). The swellable material may expand in the presence of a stimulus, such as water, conditioned drilling fluid, a completion fluid, a production fluid (i.e. hydrocarbons), other chemical, or any combination thereof. As an example, a swellable material may be placed in the sand control device **300**, which expands in the presence of hydrocarbons to form a seal between the walls of the base pipe **302** and the non-permeable section of the sand screen **304** (See e.g. Easy Well Solutions' CONSTRUCTOR™ or SwellFix's E-ZIP™ or P-ZIP™). Further, the sealing element **312** may be activated chemically, mechanically by the removal of a washpipe, and/or via a signal, electrical or hydraulic, to isolate the openings **310** from the fluid flow during some or all of the production operations. For alternative views of the sand control devices **300a** and **300b**, cross sectional views of the components is shown along the line AA in FIG. 3B, along the line BB in FIG. 3C, along the line CC in FIG. 3D, along the line DD in FIG. 3E, and along the line EE in FIG. 3G.

- 18 -

[0050] Some embodiments of the operation of the sand control device 300 are further described with reference to FIGs. 3A and 3F. In FIG. 3A, the sand control device 300a is run to a specific location within the wellbore. The sand control device 300a, which may be coupled to a crossover tool, provides one or more flow paths 314 for carrier fluid through the sand screen 304 and openings 310 into the base pipe 302 during the gravel packing operations. The carrier or gravel pack fluid may include XC gel (xanthomonas campestris or xanthan gum), visco-elastic fluids having non-Newtonian rheology properties, a fluid viscosified with hydroxyethylcellulose (HEC) polymer, a fluid viscosified with refined xanthan polymer (e.g. Kelco's XANVIS®), a fluid viscosified with visco-elastic surfactant, and/or a fluid having a favorable rheology and sand carrying capacity for gravel packing the subsurface formation of the wellbore using the at least one sand control device with alternate path technology. During the gravel packing operations, the sealing element 312 does not block the flow path 314 and provides an alternative flow path for carrier fluid in addition to the inflow control devices 308. Once the gravel pack is formed, production operations may begin as shown in FIG. 3F. In FIG. 3F, the sealing element 312 actuates to block fluid flow through the openings 310. As a result, the sand control device 300b, which may be coupled to a production tubing string 128 or other piping, may provide one or more flow paths 316 for formation fluids through the sand screen 304 and inflow control devices 308 into the base pipe 302. Thus, in the embodiment, the openings 310 are isolated to limit fluid flow to only the inflow control devices 308, which are designed to manage the flow of fluids from the interval 108.

[0051] As a specific example, the sand control device 300 may be run in a water-based mud with a hydrocarbon-swellable material used for the sealing element 312. During screen running and gravel packing operations, the chamber between the base pipe 302 and the sand screen 304 is open for fluid flow through the inflow control devices 308 and/or openings 310. However, during production operations, such as post-well testing operations, the sealing element 312 comprising a hydrocarbon-swellable material expands to close off the chamber within the perforated section 326. As a result, the fluid flow is limited to the inflow control devices 308 once the sealing element 312 comprising a hydrocarbon-swellable material isolates the openings 310.

- 19 -

[0052] Alternatively, as another example, if the sand control device 300 is run in an oil-based mud, such as non-aqueous fluid (NAF), a hydrocarbon-swellable material may again be used for the sealing element 312. In this example, the process of expanding the sealing element 312 is evaluated to determine the time associated with isolating the openings to prevent fluid flow in the well. The material comprising the sealing element 312 may be formulated so that the sealing element 312 swells at a known rate in the NAF. Alternatively, a coating or covering of a semi-permeable material that may prevent early swelling of the sealing element 312 may be applied to the sealing element 312. In either case, the expansion process may be designed to proceed at a specified rate to enable certain operations to be performed within the wellbore. After the sealing element 312 swells, the formation fluid is able to enter the interior of the base pipe 302 only through the inflow control devices 308.

[0053] Beneficially, the sand control device 300 with a swellable material may be a passive system that may automatically adjust to manage the flow of fluids into the production tubing string 128. Further, this embodiment is not complex, which reduces manufacturing costs. In addition, the sand control device 300 also provides various operational enhancements. For instance, based on the expansion of the swelling material, full well tests may be performed on the intervals within the subsurface formation before flow is diverted to only the inflow control devices 308. In addition, production operations, such as remediation or treatment operations may be performed by using chemicals, such as acids, to dissolve or shrink the swellable material to increase flow from an individual interval within the well. Alternatively, an electrical or hydraulic signal may also be used to shrink the material. Another alternative embodiment of the sand control device 300 is further described in FIGs. 4A-4G.

[0054] FIGs. 4A-4G are illustrative views of a first alternative embodiment of the sand control device of FIGs. 3A-3G in accordance with aspects of the present invention. In FIGs. 4A-4G, the sand control devices 400a and 400b, which may collectively be referred to as sand control device 400, are alternate views of a sand control device 400 in different stages of operation, such as gravel packing and production. Accordingly, the sand control device 400 utilizes the reference numerals for similar components to those described above in FIG. 3. In particular, the sand

- 20 -

control device **400** may include a main body section **410**, an inflow section **412**, a first connection section **414**, a perforated section **416** and a second connection section **418**, which are made of steel or metal alloys. Each of these sections **410-418** may include similar features, operate in a similar manner, and include similar materials to the respective sections **320-328** discussed above.

[0055] However, in this alternative embodiment, the shunt tubes **402** have been included with the sand control device **400**. The shunt tubes **402** may include packing tubes and/or transport tubes and may also be utilized with the sand screens **304** for gravel packing and other operations within the wellbore. The packing tubes may have one or more valves or nozzles (not shown) that provide a flow path for the gravel pack slurry, which includes a carrier fluid and gravel, to the annulus formed between the sand screen **304** and the walls of the wellbore. The valves may prevent fluids from an isolated interval from flowing through the at least one shunt tubes to another interval. These shunt tubes are known in the art as further described in U.S. Patent Nos. 5,515,915, 5,890,533, 6,220,345 and 6,227,303.

[0056] Accordingly, in this embodiment, the sand control device **400** includes inflow control devices **308**, openings **310**, a sealing element **312** and shunt tubes **402**. In this embodiment, the sealing element **312** may include multiple individual sections or portions, such as a plurality of sealing element **312** sections, positioned between adjacent shunt tubes **402** or a single sealing element **312** with openings for the shunt tubes **402**. The plurality of sealing element sections **312**, which may include hydraulically actuated inflatable elements or swellable materials, may block fluid flow to the openings **310** within the sand control device **400**. For an alternative perspective of the sand control devices **400a** and **400b**, cross sectional views of some of the various components are shown along the line FF in FIG. 4B, along the line GG in FIG. 4C, along the line HH in FIG. 4D, along the line II in FIG. 4E, and along the line JJ in FIG. 4G.

[0057] Some embodiments of the operation of the sand control device **400** are further described with reference to FIGs. 4A and 4F. In FIG. 4A, the sand control device **400a** is run to a specific location within the wellbore. The sand control device **400a**, which may be coupled to a crossover tool, provides one or more flow paths **404** for carrier fluid through the sand screen **304** and openings **310** into the base

- 21 -

pipe 302. During the gravel packing operations, the sealing element 312 does not block the flow path 404 and provides an alternative flow path for carrier fluid in addition to the inflow control devices 308. Once the gravel pack is formed, production operations may begin as shown in FIG. 4F. In FIG. 4F, the individual sections of the sealing element 312 swell to block fluid flow through the openings 310. As a result, the sand control device 400b, which may be coupled to a production tubing string 128 or other piping, may provide one or more flow paths 408 for formation fluids through the sand screen 304 and inflow control devices 308 into the base pipe 302. Thus, the openings 310 are isolated to limit flow through the inflow control devices 308, which manages the flow of fluids from the interval 108. Beneficially, by utilizing the shunt tubes 402, longer portions of intervals may be packed without leaking off into the formation. The leaking off into the formation typically is one of the causes of an incomplete gravel pack. Accordingly, the shunt tubes 402 providing a mechanism for forming a substantially complete gravel pack along the sand screen that bypasses sand and/or gravel bridges.

[0058] FIGs. 5A-5F are illustrative views of yet another alternative embodiment of the sand control device of FIGs. 3A-3G in accordance with aspects of the present invention. In FIGs. 5A-5F, the sand control devices 500a and 500b, which may collectively be referred to as sand control device 500, are alternate views of a sand control device 500 in different stages of operation, such as gravel packing and production. The sand control device 500 operates in a similar manner as the flow control device 400 and utilizes similar components to those described above in FIGs. 3A-3G and 4A-4G. However, in this embodiment, the sealing element 312 and shunt tubes 402 are configured to engage with support members 502 that function similar to the ribs 305 to separate the base pipe 302 from the sand screen 304. The support members 502 may seal with the shunt tubes 402 and support the shunt tubes 402 in one embodiment. Alternatively, the support members 502 may be coupled to the shunt tubes 402 via welds or threaded connections to provide an isolated flow path for fluids from each of the shunt tubes 402 through this portion of the sand control device 500. The support members 502 may be made from steel, metal alloy or other suitable material. Each of the support members 502 are positioned around or coupled to one of the shunt tubes 402 and between the base pipe 302 and the sand screen 304. The sealing element 312 is positioned between

- 22 -

adjacent support members **502**; which form a defined space for the sections of the sealing element **312** to expand and form a seal between the support members **502**, base pipe **302** and sand screen **304**. For an alternative perspective of the sand control devices **500a** and **500b**, cross sectional views of some of the various components are shown along the line **KK** in FIG. 5B, along the line **LL** in FIG. 5C, along the line **MM** in FIG. 5E and along the line **NN** in FIG. 5F.

[0059] FIGs. 6A-6G are illustrative views of still another alternative embodiment of the sand control device of FIGs. 3A-3G in accordance with aspects of the present invention. In FIGs. 6A-6G, the sand control devices **600a** and **600b**, which may collectively be referred to as sand control device **600**, are alternate views of a sand control device in different stages of operation, such as gravel packing and production. Accordingly, the sand control device **600** utilizes the reference numerals for similar components to those described above in FIGs. 3A-3G and 4A-4G. In particular, the sand control device **600** may include a main body section **610**, an inflow section **612**, a first connection section **614**, a perforated section **616** and a second connection section **618**, which may be made from steel or metal alloys. Each of these sections **610-618** may include similar features, operate in a similar manner, and include similar materials to the respective sections **320-328** discussed above.

[0060] However, in this embodiment, the shunt tubes **602** are external to the sand screen **304**. Similar to the shunt tubes **402** noted above, the shunt tubes **602** may include packing tubes, transport tubes, valves and other components utilized for gravel packing an interval within the wellbore. These shunt tubes, which may include any number of geometries, are known in the art and further described in U.S. Patent Nos. 4,945,991 and 5,113,935.

[0061] In some embodiments of the present invention, the sand control device **600** includes inflow control devices **308**, openings **310**, a sealing element **312**, and shunt tubes **602**, which operate similar to the discussion above. In particular, the sealing element **312**, which may be a single element or plurality of sealing sections, may operate in a similar manner to the discussion of FIGs. 4A-4G. That is, the sand control device **600a** of FIG. 6A, which may be coupled to a crossover tool, provides one or more flow paths **604** for carrier fluid through the sand screen **304** and

- 23 -

openings **310** into the base pipe **302** during the gravel packing operations. Once the gravel pack is formed, the sand control device **600b**, which may be coupled to a production tubing string **128** or other piping, may provide one or more flow paths **608** for formation fluids through the sand screen **304** and inflow control devices **308** into the base pipe **302**, as shown in FIG. 4F. For an alternative perspective of the sand control devices **600a** and **600b**, cross sectional views of some of the components are shown along the line OO in FIG. 6B, along the line PP in FIG. 6C, along the line QQ in FIG. 6D, along the line RR in FIG. 6E, and along the line SS in FIG. 6G.

[0062] As another example, FIGs. 7A-7B are illustrative views of another alternative embodiment of a sand control device utilized in the production system of FIG. 1 having an inflow control mechanism having a sealing element in accordance with aspects of the present invention. Similar to the discussion of FIGs. 3A-3G, the sand control devices **700a** and **700b**, which may collectively be referred to as sand control device **700**, are alternate views of a sand control device in different stages of operation, such as gravel packing and production. The sand control device **700** has inflow control devices **308**, openings **310** and sealing element **312**, which operate similar to the discussion above. However, with this embodiment of the sand control device **700**, the inflow control devices **308**, openings **310** and sealing element **312** are positioned on the same end of the sand control device **700**.

[0063] In some embodiments of the present invention, the sand control device **700** includes various sections, such as a main body section **702**, an inflow section **704**, a perforated section **706**, a first connection section **708** and a second connection section **710**, which are made of steel or metal alloys, as noted above. The main body section **702** and connection sections **708** and **710** may be configured similar to the sections **320**, **324** and **328**, which are discussed above. However, in this embodiment, while the inflow section **704** and perforated section **706** may be configured to have similar lengths to **322** and **326**, as discussed of FIGs. 3A-3G, the inflow section **704** and perforated section **706** are positioned on the same end of the sand control device **700**.

[0064] In some embodiments of the present invention, the sand control device **700** is run to a specific location within the wellbore. In FIG. 7A, the sand control

- 24 -

device 700, which may be coupled to a crossover tool, provides one or more flow paths 712 for carrier fluid through the sand screen 304 and openings 310 into the base pipe 302. Again, during the gravel packing operations, the sealing element 312 does not block the flow path 712 to provide an alternative flow path for carrier fluid. Once the gravel pack is formed, production operations may begin as shown in FIG. 7B. In FIG. 7B, the sealing element 312 swells to block fluid flow through the openings 310. As a result, the sand control device 700b, which may be coupled to a production tubing string 128 or other piping, may provide one or more flow paths 714 for formation fluids through the sand screen 304 and inflow control devices 308 into the base pipe 302. Thus, the openings 310 are isolated to limit flow through the inflow control devices 308, which manage the flow of fluids from the interval 108.

Sand Control Device with Conduit

[0065] FIGs. 8A-8C are illustrative views of an embodiment of a sand control device utilized in the production system of FIG. 1 with an inflow control mechanism having a conduit in accordance with aspects of the present invention. In FIGs. 8A-8C, the sand control device 800 utilizes the reference numerals for similar components to those described above in FIGs. 3A-3G. However, in this embodiment, one or more conduits, which are shown as a single conduit 802 for simplicity, and barrier element 804 are utilized to provide the frictional pressure loss for the sand control device instead of the inflow control devices 308. Accordingly, the conduit 802 and barrier element 804 may enhance gravel packing and production operations within the wellbore, as described herein.

[0066] In an exemplary embodiment 800, the sand control device 800 includes a main body section 810, a perforation section 812, a first connection section 814 and a second connection section 816, which may be made from steel or metal alloys. Similar to the sections 320, 324 and 326 of FIGs. 3A-3G, the sections 810, 814 and section 816 may be made from similar material, include similar components and be configured in a similar manner, as noted above. The perforated section 812 may be made of steel and/or metal alloys and configured to be between about 4 in and about 4 ft, having specific internal and outer diameters.

- 25 -

[0067] In an exemplary embodiment, the sand control device 800 includes a conduit 802 and barrier element 804 that are used to manage the flow of fluids during the gravel packing and production operations. The conduit 802 may include one or more tubes (similar to a shunt tube 402 of FIG. 4), one or more channels, or other similar fluid passages. The conduit 802 extends between the isolated chambers formed between the base pipe 302, sand screen 304 and barrier element 804 within the main body section 302 and the perforated section 812. The conduit 802 has a pre-defined diameter and length to provide adequate leak-off during the gravel pack process to achieve a complete or substantially complete pack. For instance, in different embodiments, the conduit 802 may have diameter from 1/4 in to 1 in, may include from 1 to 36 conduits, and have a length d of about 10 feet (ft) to about 50 ft. In addition, the diameter and length of the tube may be selected to provide sufficient choking through frictional pressure losses during production operations to operate similar to inflow control devices. The diameter and length of the conduit 802 may be determined from experience, fluid properties, modeling and/or calculations (i.e. computational fluid dynamics calculations or equations that involve the properties of the carrier fluid and formation fluids for the different operations). The barrier element 804 may be formed from steel, metal alloys, swellable material (i.e. the sealing element 312), and/or other suitable material that forms to isolate the chambers in the main body section 810 and the perforated section 812 from each other. For an alternative perspective of the sand control device 800, a cross sectional view of the components is shown along the line TT in FIG. 8B and along the line UU in FIG. 8C.

[0068] In some methods of operation of the present invention, the sand control device 800 is run to a specific location within the wellbore. During gravel packing and production operations, fluid flows along the flow path 806, which enters through the sand screen 304 into the first chamber, flows through the conduit 802 to the second chamber, and enters the base pipe 302 through the perforations 310. For gravel packing operations, the carrier fluid flows through the conduit 802 in a manner that allows the gravel pack to be formed around the sand control device 800. Accordingly, the carrier fluid utilized for the gravel packing operations may be designed to have reduced friction loss properties relative to water or hydrocarbons. For example, the carrier fluid may include fluids used for alternate path gravel

- 26 -

packing operations, as noted above. By selecting carrier fluids with low friction loss properties, the carrier fluid and gravel may be flowed through the well to form the gravel pack that is substantially complete. However, hydrocarbon and water production, which inherently have higher frictional pressure drop, are more restricted resulting in an inflow control effect.

[0069] As a specific example, the pressure loss for conduits may be calculated and utilized to select the pipes, which enhance operations over inflow control devices, such as nozzles. Specifically, if the pressure losses during production operations are calculated to utilize two 4 millimeter (mm) nozzles, then two conduits having a length of 30 ft and a diameter of 10 mm may be utilized during production operations. The pressure loss or choking, for both the nozzles and conduits, is about 150 psi at 550 barrels of oil per day (bopd) per screen joint. However, the nozzles and conduits may function differently during gravel packing operations. For instance, the carrier fluid may be an XC gel that flows at ½ barrel per minute (bpm) for each sand control device. The resulting pressure loss of the nozzles, which may be about 500 pounds per square inch (psi), is about 5 times the pressure loss of two conduits, which may be about 100 psi.

[0070] Beneficially, the conduit **802** and chamber formed by the barrier element **804** are utilized to choke the flow of hydrocarbons and water with frictional pressure losses, as opposed to pressure losses from inflow control devices or nozzles. While both techniques operate in a similar manner for production operations, the conduit **802** provides a mechanism for gravel packing operations to be performed efficiently, while the inflow control devices only tend to choke back the carrier fluid and hinder gravel pack formation.

[0071] Another alternative embodiment of the sand control device **800** is further described in FIGs. 9A-9E. FIGs. 9A-9E are illustrative views of a first alternative embodiment of sand control devices of FIGs. 8A-8C in accordance with aspects of the present invention. FIGs. 9A-9E show alternative views of the sand control device **900** in different stages of operation, such as gravel packing and production, with the addition of internal shunt tubes **402**. Accordingly, the sand control device **900** utilizes the reference numerals for similar components to those described above in FIGs. 3A-3G, 4A-4G and 8A-8C. In this embodiment, the shunt tubes **402** have

- 27 -

been included with the sand control device 900 to provide a mechanism for gravel packing other portions of the wellbore through the sand control device 900, as is described below. Again, as noted above, the shunt tubes 402 may include packing tubes and/or transport tubes and may also be utilized with the sand screens 304 for gravel packing within the wellbore.

[0072] In FIGs. 9A-9G, the sand control device 900 includes openings 310, shunt tubes 402, conduit 802 and barrier element 804. The barrier element 804 is positioned between the base pipe 302 and the sand screen 304 to isolate the chambers in the main body section 810 and the perforated section 812 from each other. Accordingly, in this embodiment, the barrier element 804 may include multiple individual sections, such as a plurality of barrier sections, positioned between adjacent shunt tubes 402 and/or conduit 802 or may be a single element with openings for the shunt tubes 402 and/or conduit 802. Fluid from the interval may flow along the path 902 for gravel packing and production operations. For an alternative perspective of the sand control device 900, cross sectional views of some of the components are shown along the line VV in FIG. 9B, along the line WW in FIG. 9C, along the line XX in FIG. 9D and along the line YY in FIG. 9E.

[0073] As another example, FIGs. 10A-10C are illustrative views of a second alternative embodiment of sand control device of FIGs. 8A-8C in accordance with aspects of the present invention. FIGs. 10A-10C show alternative views of a sand control device 1000 in different stages of operation, such as gravel packing and production, with the addition of external shunt tubes 602. Accordingly, the sand control device 1000 utilizes the reference numerals for similar components to those described above in FIGs. 3A-3G, 6A-6G and 8A-8C. In this embodiment, the shunt tubes 602 have been included with the sand control device 1000 to provide a mechanism for gravel packing other portions of the wellbore through the sand control device 1000, as described below. Again, the shunt tubes 602 may include packing tubes and/or transport tubes to gravel pack the sand control device 1000 within the wellbore.

[0074] In FIGs. 10A-10C, the sand control device 1000 includes openings 310, shunt tubes 602, conduit 802 and barrier element 804. The barrier element 804 is positioned between the base pipe 302 and the sand screen 304 to isolate the

- 28 -

chambers in the main body section **810** and the perforated section **812** from each other. Accordingly, in this embodiment, the barrier element **804** may be a single element with openings for the conduit **802**. Fluid from the interval may flow along the path **1002** for gravel packing and production operations. For an alternative perspective of the sand control device **1000**, cross sectional views of some of the various components are shown along the line **ZZ** in FIG. 10B and along the line **A'A'** in FIG. 10C.

Sand Control Device with Sliding Sleeve

[0075] FIGs. 11A-11F are illustrative views of yet another alternative embodiment of a sand control device utilized in the production system of FIG. 1 with an inflow control mechanism having a sleeve in accordance with aspects of the present invention. FIGs. 11A-11F show alternative views of the sand control devices **1100a-1100f** in different stages of operation, utilizing the reference numerals for similar components to those described above in FIGs. 3A-3G. However, in this embodiment, a sleeve **1102**, which may be adjusted into a plurality of positions, such as a running position, gravel packing position, and production position, is utilized to control flow paths through the sand control devices **1100a-1100f**, which may collectively be referred to as sand control device **1100**. For example, the sleeve **1102** in FIGs. 11A-11C is configured to rotate around the circumference of the base pipe **302** in the directions indicated by the arrows **1104** and **1106**, while the sleeve **1102** in FIGs. 11D-11F is configured to slide along the longitudinal axis of the base pipe **302** in the directions indicated by the arrows **1107** and **1108**. Regardless of the specific sleeve configuration, the sleeve **1102** is adjustable to control the pressure loss for the different well operations and may be disposed externally or internally adjacent to the base pipe **302**.

[0076] In one exemplary embodiment, the sand control device **1100** includes a main body section **1110**, a perforation section **1112**, a first connection section **1114** and a second connection section **1116**, which are made of steel or metal alloys. Similar to the sections **320**, **324** and **326** of FIGs. 3A-3G, the sections **1110**, **1114** and section **1116** may be made from similar material, include similar components and be configured in a similar manner, as noted above. The perforated section **1112**

- 29 -

may be made of steel and/or metal alloys and configured to be between about 4 in and about 4 ft, having specific internal and outer diameters.

[0077] In some embodiments, the sand control device **1100** may further include an inflow control device **308**, openings **310**, and a sleeve **1102** that are used to manage the flow of fluids during running, gravel packing and production operations. The sleeve **1102** may include a body of steel or metal alloy having a sealing element secured to the body. While the sleeve **1102** is shown positioned externally around the base pipe **302**, the sleeve **1102** may also be disposed internal to the base pipe **302** in other embodiments.

[0078] In some embodiments of the operation of the present invention, the sleeve **1102** is configured to move between different positions, such as a running position as shown in FIGs. 11A and 11D, a gravel packing position as shown in FIGs. 11B and 11E, and a production position as shown in FIGs. 11C and 11F. For example, as shown in FIGs. 11A and 11D, the sleeve **1102** may be biased into the running position by a biasing member (not shown). In the running position, the sleeve **1102** may block fluid flow into the inflow control device **308** and the openings **310** by forming a seal that covers these components. Then, the sleeve **1102** may be moved into the gravel packing position by moving a washpipe through the sand control device **1100a**. The movement of the washpipe may break or disengage the biasing member. In the gravel packing position, the sleeve **1102** may block fluid flow into the inflow control device **308**, but provide a fluid path through the openings **310**, as shown in FIGs. 11B and 11E. In this manner, the carrier fluid may return from the wellbore through the sand screen **304** and into the openings **310**. Once the gravel pack is formed, the washpipe may be removed from the sand control device **1100b**. The removal of the washpipe may move the sleeve **1102** into the production position, as shown in FIGs. 11C and 11F. In the production position, the sleeve **1102** may block fluid flow into the openings **310**, but provide a fluid path through the inflow control device **308**. In this manner, the formation fluid, such as hydrocarbons, may flow from the wellbore through the sand screen **304** and inflow control device **310** into the base pipe **302**. It should be noted that the sleeve **1102**, which may be controlled electrically or hydraulically as well, may be moved into the running position to block flow from the interval if water production is detected.

- 30 -

[0079] Beneficially, the sleeve **1102** having multiple positions may be utilized to manage the flow of fluids from the wellbore in an efficient manner. The sleeve **1102** provides additional flexibility for production operations and may reduce potential workovers by isolating the interval or portion of the interval adjacent to the sand control device **1100**. However, note that the rotation of the sleeve may also include helical or other radial movement or rotation in other configurations.

[0080] As noted, the problems with the water/gas production may include productivity loss, equipment damage, and/or increased treating, handling and disposal costs. These problems are further compounded for wells having a number of different completion intervals, such as intervals **108a-108n**, and where the formation strength may vary from interval to interval. As such, water or gas breakthrough in any one of the intervals may threaten the remaining reserves within the well. Accordingly, to provide the zonal isolation or manage the flow of fluids within the wellbore **114**, packers may be utilized with the sand control devices **138a-138n**, which may include one or more of the embodiments **300, 400, 500, 600, 700** and **1100**, as discussed below in FIG. 12.

[0081] FIG. 12 is an alternative exemplary production system **1200** in accordance with certain aspects of the present invention. The exemplary production system **1200** utilizes the reference numerals for similar components to those described above in FIG. 1. However, packers **1202a-1202n**, wherein number "n" is any integer number, are utilized in this embodiment to isolate various intervals **108a-108n** of the wellbore **114** from each other. The packers **1202a-1202n** may include any suitable packers, such as the packers described in U.S. Provisional Application 60/765,023. Accordingly, in this embodiment, the various embodiments of sand control devices **138** along with the packers **1202a-1202n** may be utilized to manage the flow of hydrocarbons or provide zonal isolation within the well.

[0082] As an example, to manage the flow of hydrocarbons, the sand control devices **138a-138n** may include one or more of the embodiments **300, 400, 500, 600, 700** and **1100**. If the sand control device **138** includes a water-swelling material as the sealing element **312** or has a sleeve **1102**, the openings **310** may be utilized for gravel packing and production operations to maximize the production flow until water is produced from the interval. Once water is produced, the sealing

- 31 -

element **312** may expand or the sleeve may be adjusted to the production position to seal the openings **310** from the formation fluid. As a result, the inflow control devices **308** are the only path from the interval to the interior of the base pipe **302**. Beneficially, this embodiment may limit the impact of water production from one of the intervals of the formation.

[0083] To provide zonal isolation within the wellbore **114**, the packers **1202a-1202n** may be utilized with the sand control devices **138a-138n**, which may include at least the embodiment **1100**. In this example, the sand control device **138** may include a sleeve **1102** configured to provide or block access to the inflow control device **308** and openings **310**. The openings **310** may be utilized for gravel packing, while the inflow control device **308** may be utilized for production operations. Once water is produced, the sleeve **1102** may be moved to the running position to seal the openings **310** and inflow control device **308** from the water. As a result, at least one sand control device **138** and two adjacent packers **1202a-1202n** may be utilized to seal an interval within the wellbore **114**. Alternatively, a water-swellaable packer can be used for the same function when combined with any of the embodiments.

[0084] As alternative embodiments, different geometric patterns or any numbers of tubes, such as shunt tubes **402** and **602** and conduit **802**, may be utilized for different applications. These tubes may be configured to provide redundancy flow paths or baffling (staggering) within the sand control devices **138**. For example, while the sand control device **400** is shown with nine internal shunt tubes **402**, sand control devices may include any number of shunt tubes, such as a one, two, three, four, five, six, seven, eight or more depending on the specific application. Also, while the sand control device **600** is shown with four external shunt tubes **602**, sand control devices may include any number of shunt tubes, such as a one, two, three, four or more depending again on the specific application. Further, while the sand control device **800** is shown with one conduit **802**, sand control devices may include any number of conduits, such as a one, two, three, four or more depending again on the specific application. In addition, it should again be noted that the tubes may include a variety of shapes and may be selected based upon on space limitations, pressure loss, and burst/collapse capacity. For instance, the tubes may be circular, rectangular, trapezoidal, polygons, or other shapes for different applications.

- 32 -

[0085] Similarly, the tubular members, such as base pipe 302 and sand screen 304, may include different geometric patterns, as discussed with the tubes, for different applications. For instance, the tubular member may include shapes, such as circular, rectangular, trapezoidal, polygons, or other shapes for different application. Also, while these tubular members are shown in a concentric configuration, eccentric configurations may also be utilized depending on the specific applications.

[0086] Further, these embodiments may be utilized with gravel placement procedures (i.e. gravel packing operations), which are discussed in U.S. Patent Application No. 60/765,023. For instance, a wellbore may be drilled with a drilling fluid to access a subsurface formation. The drilling fluid may be conditioned, by shakers and other equipment to remove material above a certain size. Then, one or more sand control devices may be positioned within or run into a wellbore adjacent to a subsurface formation in the conditioned drilling mud. The sand control devices may be any of the embodiments of the present invention disclosed herein, and/or other configurations already known or unknown, or some combination thereof. The sand control device may include inflow control mechanism to provide pressure loss during gravel packing operations that are less than the pressure loss during some of the production operations. A crossover tool may be coupled to or engaged with the sand control device and a packer may be set above the sand control device to isolate the wellbore above the sand control device. Once set, the conditioned drilling fluid adjacent to the sand control device may be displaced with a carrier fluid. Then, the carrier fluid with gravel may be circulated through the cross over tool to form a gravel pack around the sand control device within the wellbore. Then, the crossover tool may be disengaged from the sand control device and a production tubing string may be coupled to the sand control device. Then, an adjustment may be made to the sand control device to limit the fluid flow during production operations, in the different approaches discussed above. Then, hydrocarbons may be produced through the gravel pack and sand control device.

[0087] It should be noted that the term "above," when used to describe the position of a device in a well should be construed broadly and not limited to mean "closer to the surface." As is known, some wells may be horizontal or even have a slight upward angle such that a device that is closer to the surface may be farther

- 33 -

"down" the production string if the path of the well is taken. Here, "above" or "below," when used in the context of a production string arrangement refers to the path of the production string, not the straight line distance to the earth's surface.

[0088] While the present invention may be susceptible to various modifications and alternative forms, the exemplary embodiments discussed above have been shown only by way of example. However, it should again be understood that the invention is not intended to be limited to the particular embodiments disclosed herein. Indeed, the present invention includes all alternatives, modifications, and equivalents.

CLAIMS:

1. An apparatus for producing hydrocarbons comprising:
 - a first tubular member having a permeable section and a non permeable section;
 - a second tubular member disposed within the first tubular member, wherein the second tubular member has a plurality of openings that provide a fluid flow path into the interior of the second tubular member;
 - a barrier element disposed between the first tubular member and the second tubular member, the barrier element being configured to isolate a first chamber from a second chamber formed between the first tubular member and second tubular member, wherein the first chamber includes the permeable section of the first tubular member and the second chamber includes the plurality of openings in the second tubular member;
 - at least one conduit disposed between the first tubular member and second tubular member, wherein the at least one conduit provides at least one fluid flow path between the first chamber and the second chamber through the barrier element; wherein the at least one conduit is configured to provide adequate leak-off during gravel packing operations and to provide sufficient choking during production operations; and
 - at least one shunt tube secured to at least one of the first tubular member and the second tubular member and configured to pass through the barrier element.
2. The apparatus of claim 1, wherein the first tubular member comprises a sand screen and the permeable section comprises a filter medium.
3. The apparatus of claim 2, wherein the filter medium is one of mesh screen, wire wrapping, a medium to prevent a predetermined particle size and any combination thereof.
4. The apparatus of any one of claims 1 to 3, wherein the second tubular member comprises a base pipe.
5. The apparatus of any one of claims 1 to 4, wherein the at least one shunt tube is disposed between the first tubular member and the second tubular member.

- 35 -

6. The apparatus of claim 5, wherein the at least one shunt tube comprises a plurality of shunt tubes and the barrier element comprises a plurality of sections disposed between two of the plurality of shunt tubes or between one of the plurality of shunt tubes and one of the at least one conduit.
7. The apparatus of claim 1 further comprising at least one rib disposed between the first tubular member and the second tubular member to support the permeable section of the first tubular member.
8. The apparatus of any one of claims 1 to 7, wherein the at least one conduit comprises one of a tube, channel and any combination thereof.
9. The apparatus of any one of claims 1 to 8, wherein the gravel packing operations utilize at least one non-Newtonian fluid.
10. An apparatus for producing hydrocarbons comprising:
 - a first tubular member having a permeable section and a non permeable section;
 - a second tubular member disposed within the first tubular member, wherein the second tubular member has a plurality of openings and at least one inflow control device;
 - at least one shunt tube secured to at least one of the first tubular member and the second tubular member; and
 - a sleeve disposed adjacent to the second tubular member and configured to move between a plurality of positions, wherein the plurality of positions comprises:
 - a first position providing a first flow path into the interior of the second tubular member from the permeable section of the first tubular member through at least the plurality of openings; and
 - a second position providing a second flow path into the interior of the second tubular member from the permeable section of the first tubular member through the at least one inflow control device, wherein fluid flow is prevented through the plurality of openings.

- 36 -

11. The apparatus of claim 10, wherein the plurality of positions further comprise a third position preventing fluid flow into the interior of the second tubular member.
12. The apparatus of any one of claims 10 to 12, wherein the first tubular member comprises a sand screen and the permeable section comprises a filter medium.
13. The apparatus of claim 12, wherein the filter medium is one of mesh screen, wire wrapping, a medium to prevent a predetermined particle size and any combination thereof.
14. The apparatus of any one of claims 10 to 13, wherein the second tubular member comprises a base pipe.
15. The apparatus of any one of claims 10 to 14, wherein the at least one shunt tube is disposed between the first tubular member and the second tubular member.
16. The apparatus of claim 15, further comprising a support member disposed around the at least one shunt tube and secured to at least one of the first tubular member and the second tubular member.
17. The apparatus of claim 10 further comprising at least one rib disposed between the first tubular member and the second tubular member to support the permeable section of the first tubular member.
18. The apparatus of any one of claims 10 to 17, wherein the plurality of openings and at least one inflow control device are positioned on the same end of the apparatus.
19. The apparatus of any one of claims 10 to 17, wherein the plurality of openings and at least one inflow control device are positioned on opposite ends of the apparatus.
20. The apparatus of any one of claims 10 to 19, wherein the at least one inflow control device comprises one of nozzle, tortuous path, tube and any combination thereof.

- 37 -

21. The apparatus of any one of claims 10 to 17, wherein the plurality of openings comprises perforations in the second tubular member.
22. The apparatus of any one of claims 10 to 20, wherein the sleeve is configured to rotate at least partially around the second tubular member.
23. The apparatus of any one of claims 10 to 20, wherein the sleeve is configured to slide at least partially along the second tubular member.
24. The apparatus of any one of claims 10 to 23, wherein the sleeve is external to the second tubular member.
25. The apparatus of any one of claims 10 to 23, wherein the sleeve is internal to the second tubular member.
26. A method of producing hydrocarbons from a well, the method comprising:
 - disposing at least one sand control device within a wellbore adjacent to a subsurface formation, wherein at least one of the at least one sand control device comprises:
 - a first tubular member having a permeable section and a non permeable section;
 - a second tubular member disposed within the first tubular member, wherein the second tubular member has a plurality of openings that provide a fluid flow path into the interior of the second tubular member; and
 - a barrier element disposed between the first tubular member and the second tubular member, the barrier element being configured to isolate a first chamber from a second chamber formed between the first tubular member and second tubular member, wherein the first chamber includes the permeable section of the first tubular member and the second chamber includes the plurality of openings in the second tubular member; and
 - at least one conduit disposed between the first tubular member and second tubular member, wherein the at least one conduit provides at least one fluid flow

- 38 -

path between the first chamber and the second chamber through the barrier element; wherein the at least one conduit is configured to provide adequate leak-off during gravel packing operations and to provide sufficient choking during production operations;

gravel packing the at least one sand control device within the wellbore utilizing at least one non-Newtonian fluid, wherein the at least one conduit is configured to pass the non-Newtonian fluid with substantially no restriction; and

producing hydrocarbons through the at least one sand control device by passing hydrocarbons through the at least one conduit of the at least one sand control device; wherein the at least one conduit is configured to apply a predetermined choke to the flow of hydrocarbons through the conduit.

Application number / numéro de demande: 2787840

Figures: _____

Pages: 1, 5, 6, 7, 8, 10, 13, 14, 17

Unscannable items
received with this application
(Request original documents in File Prep. Section on the 10th floor)

Documents reçu avec cette demande ne pouvant être balayés
(Commander les documents originaux dans la section de préparation des dossiers au
10^{ème} étage)

2/17

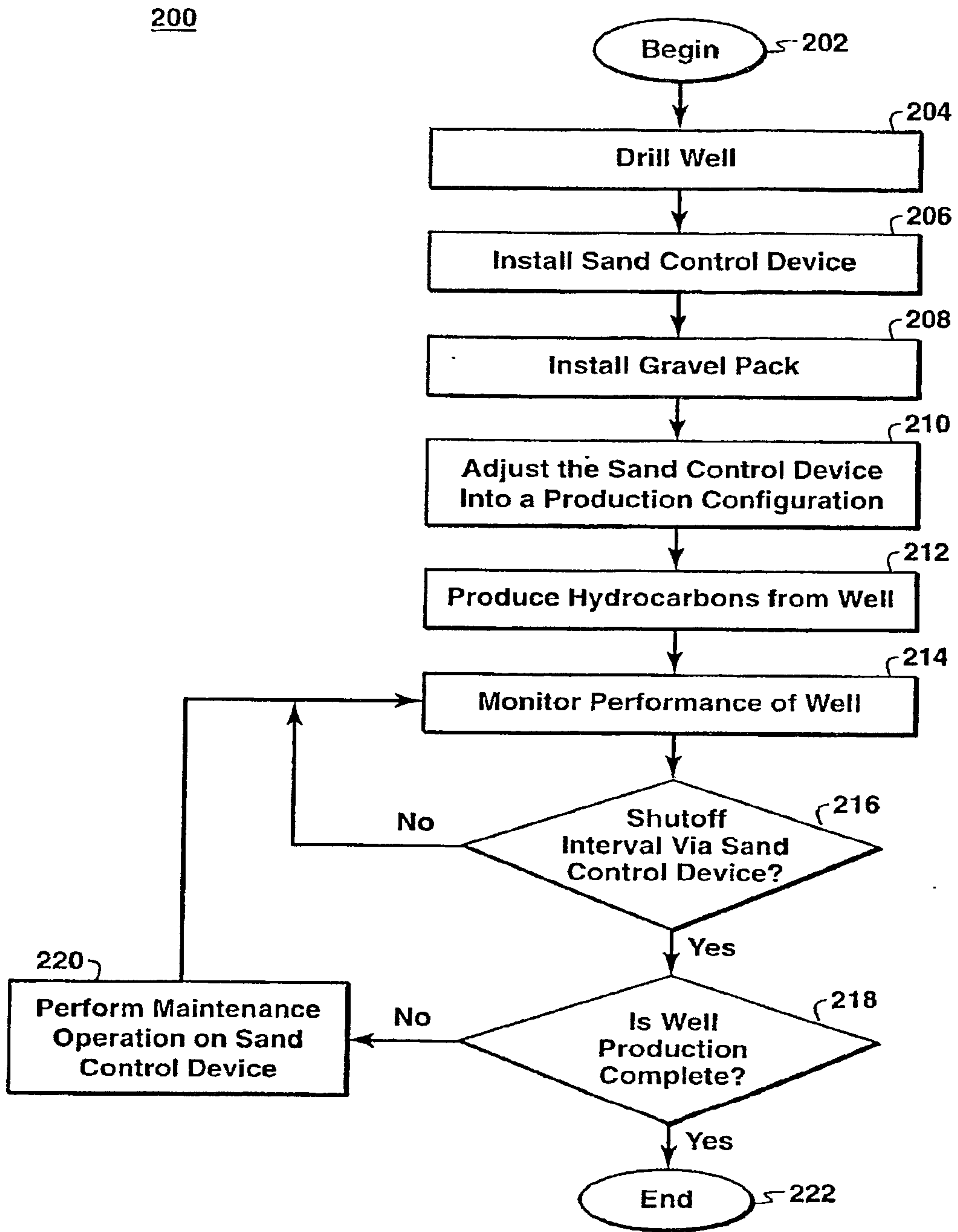

FIG. 2

3/17

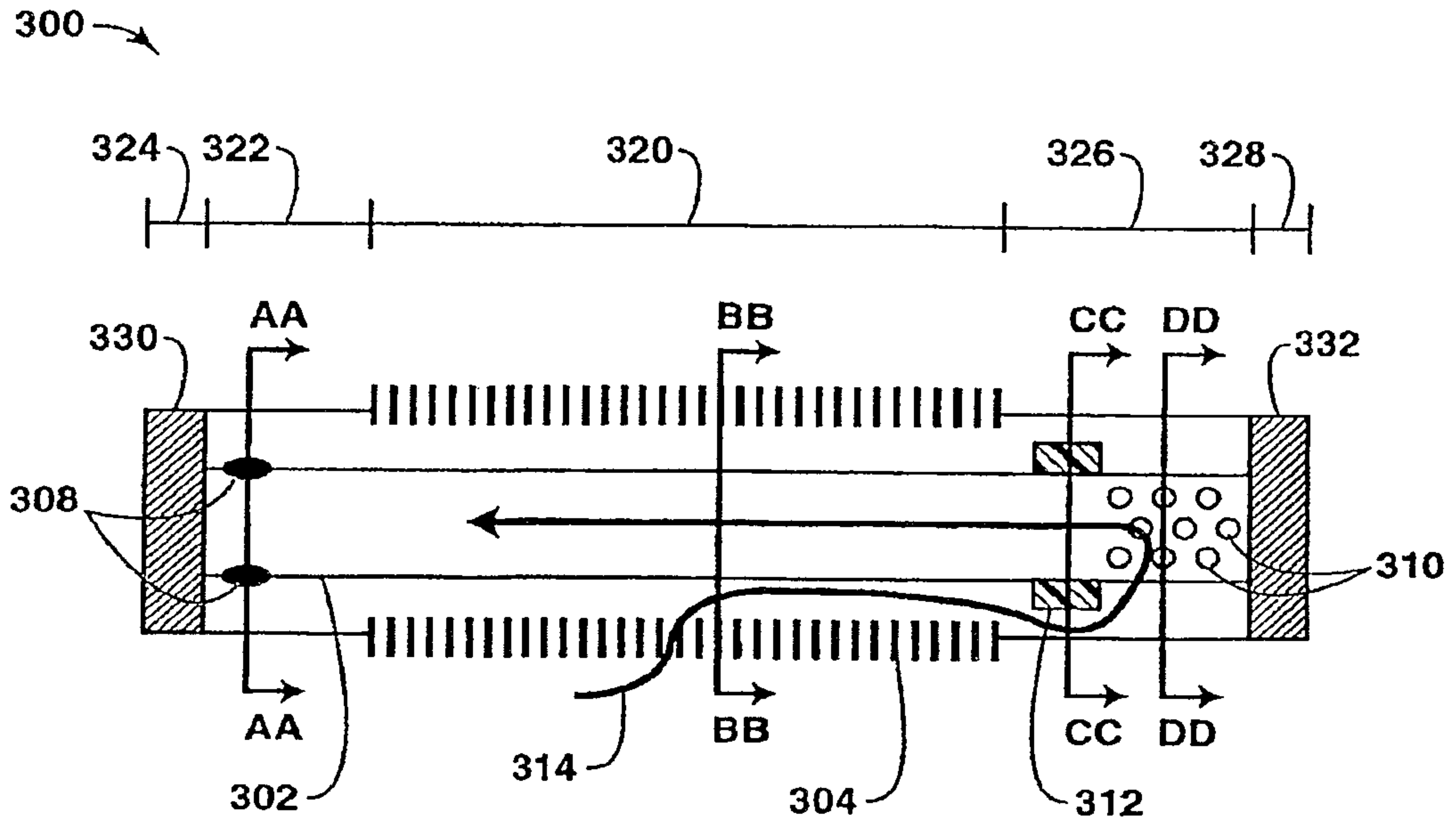
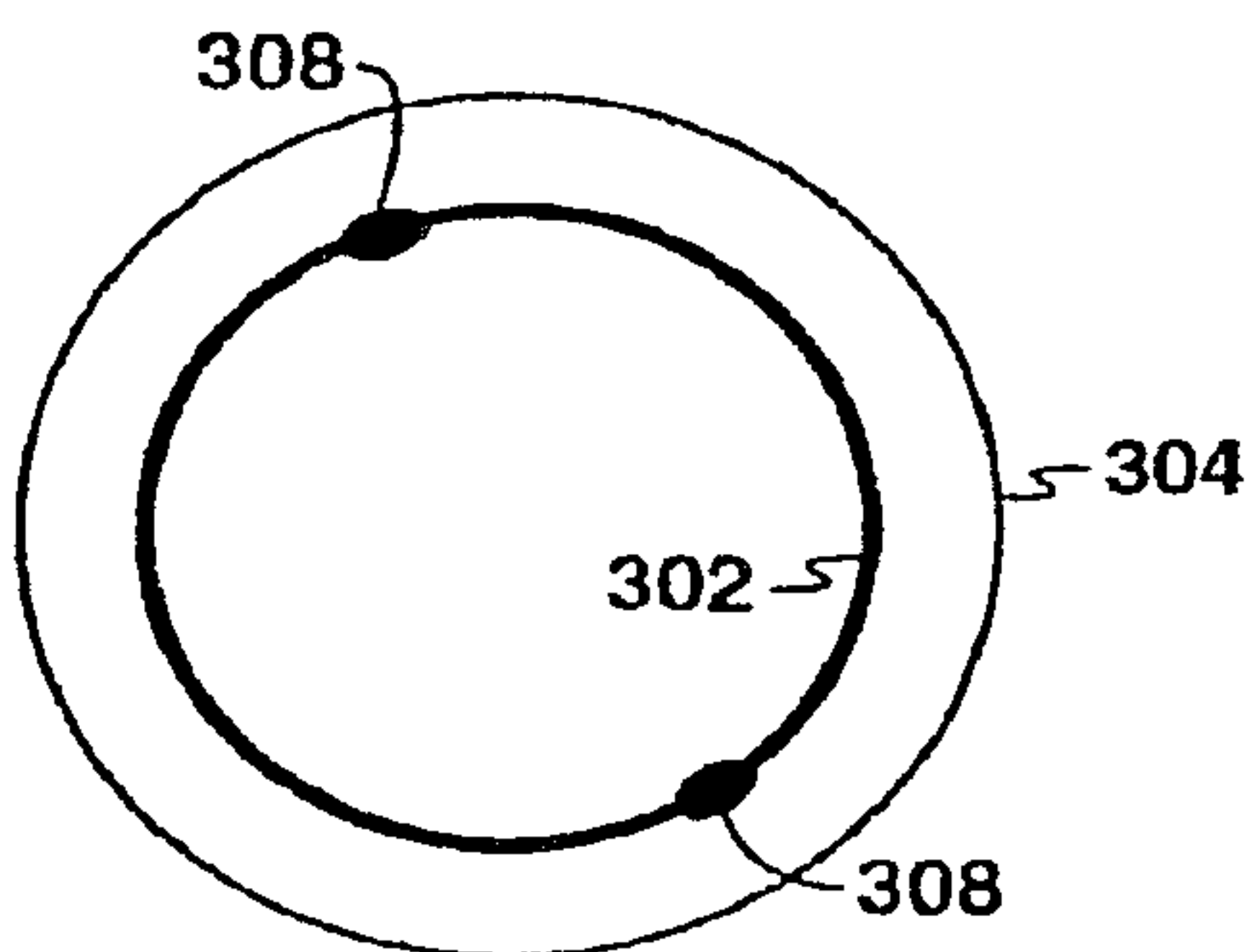
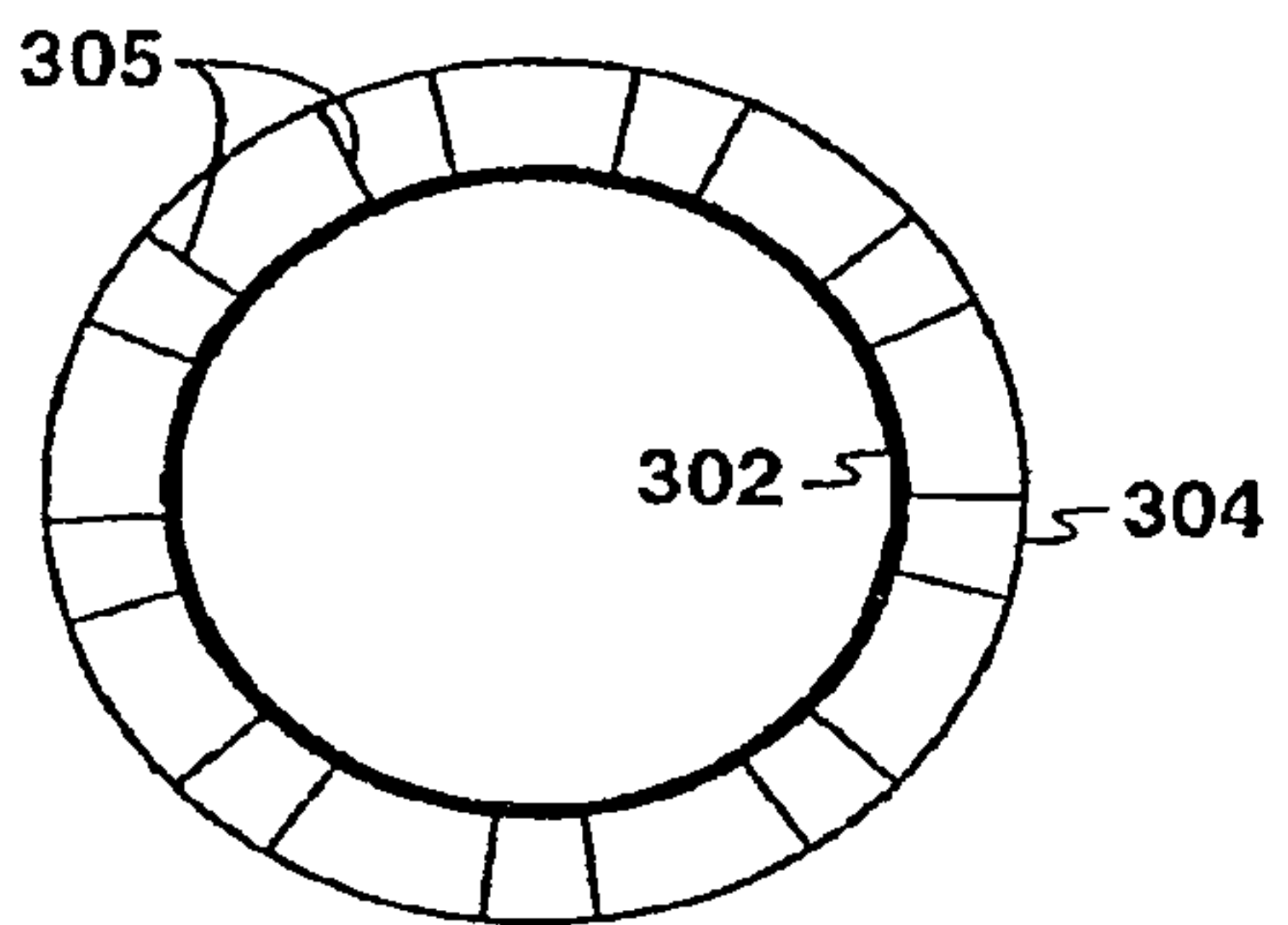

FIG. 3A



A-A

FIG. 3B



B-B

FIG. 3C

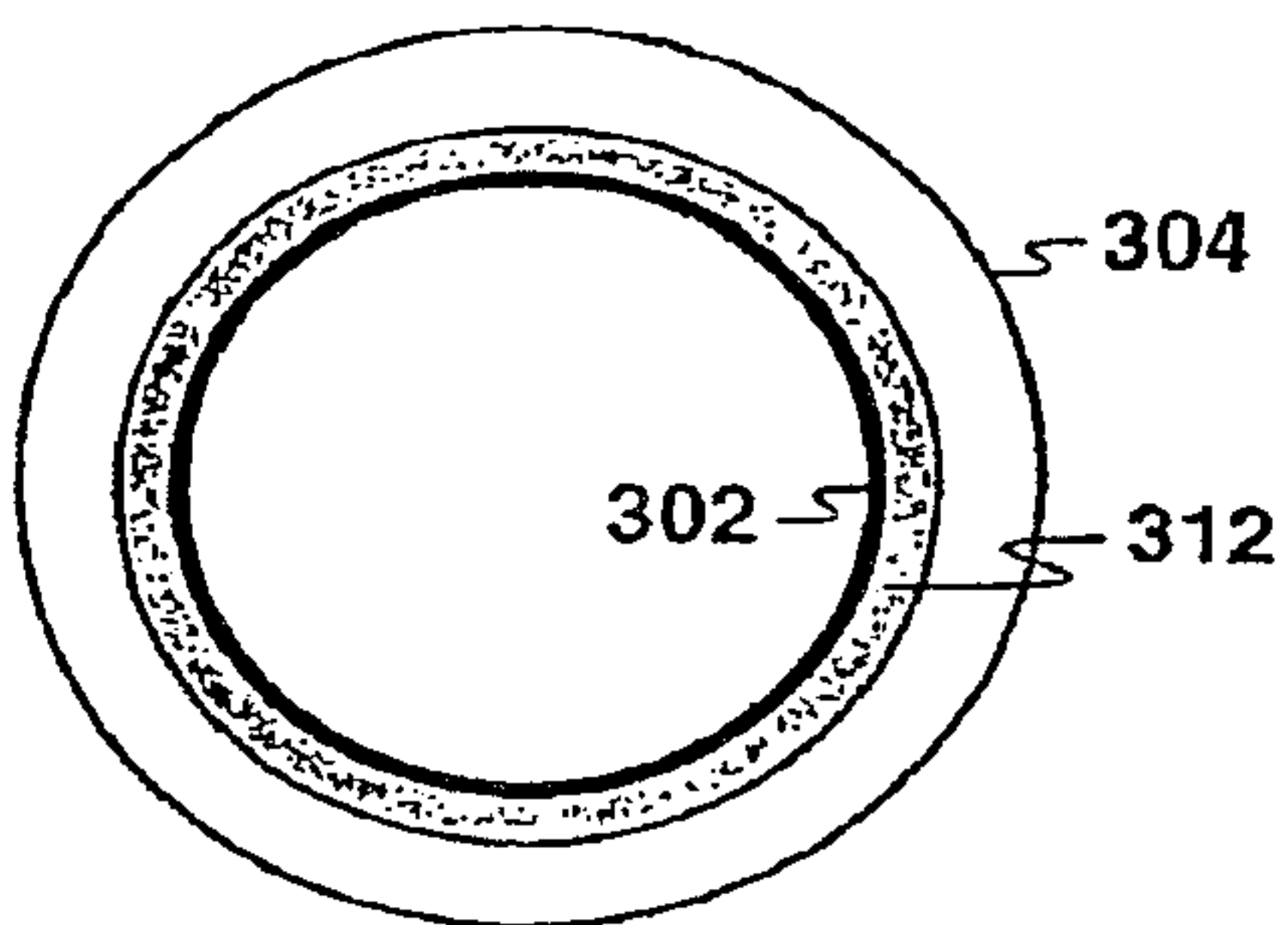

C-C

FIG. 3D

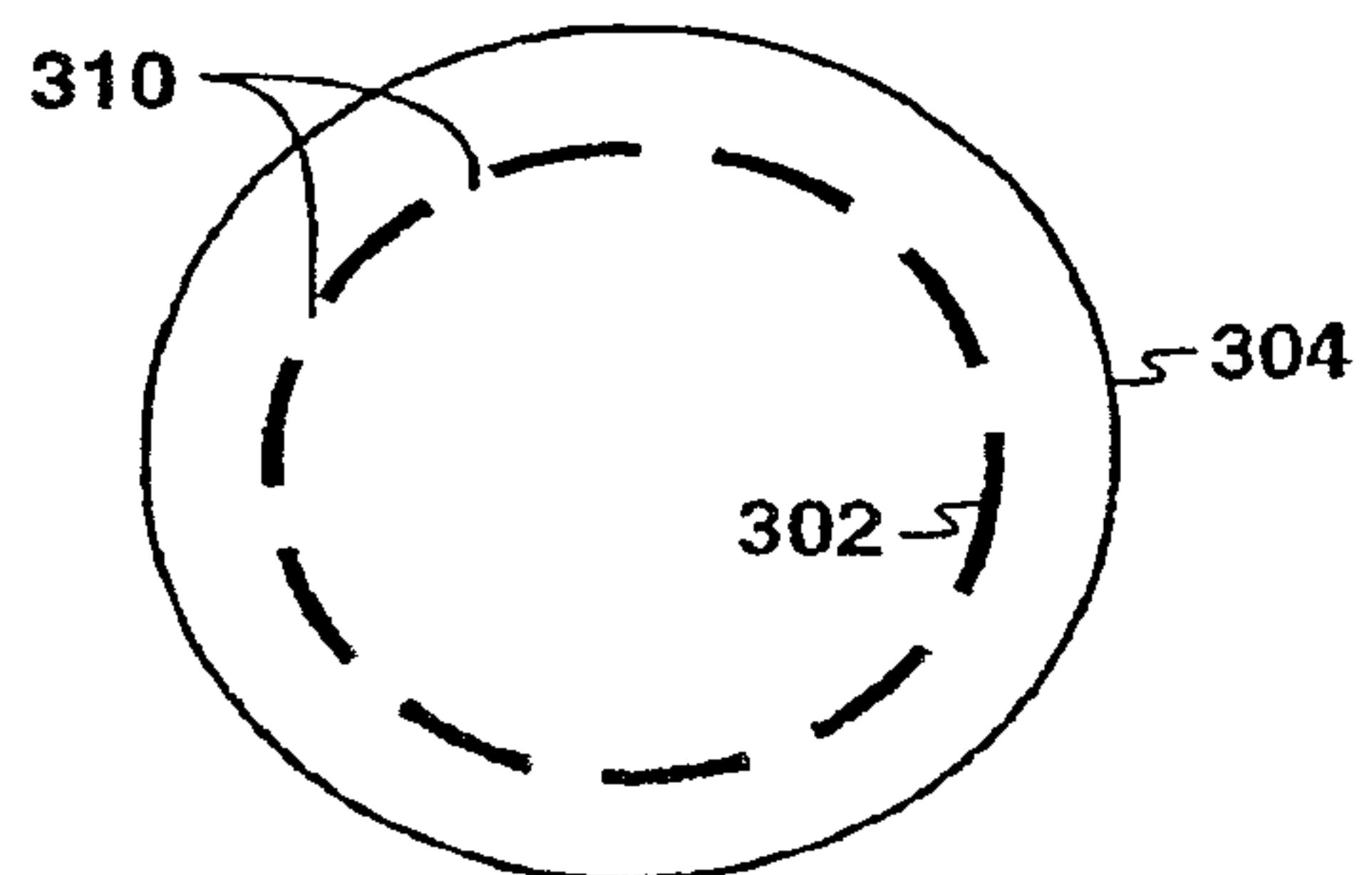

D-D

FIG. 3E

4/17

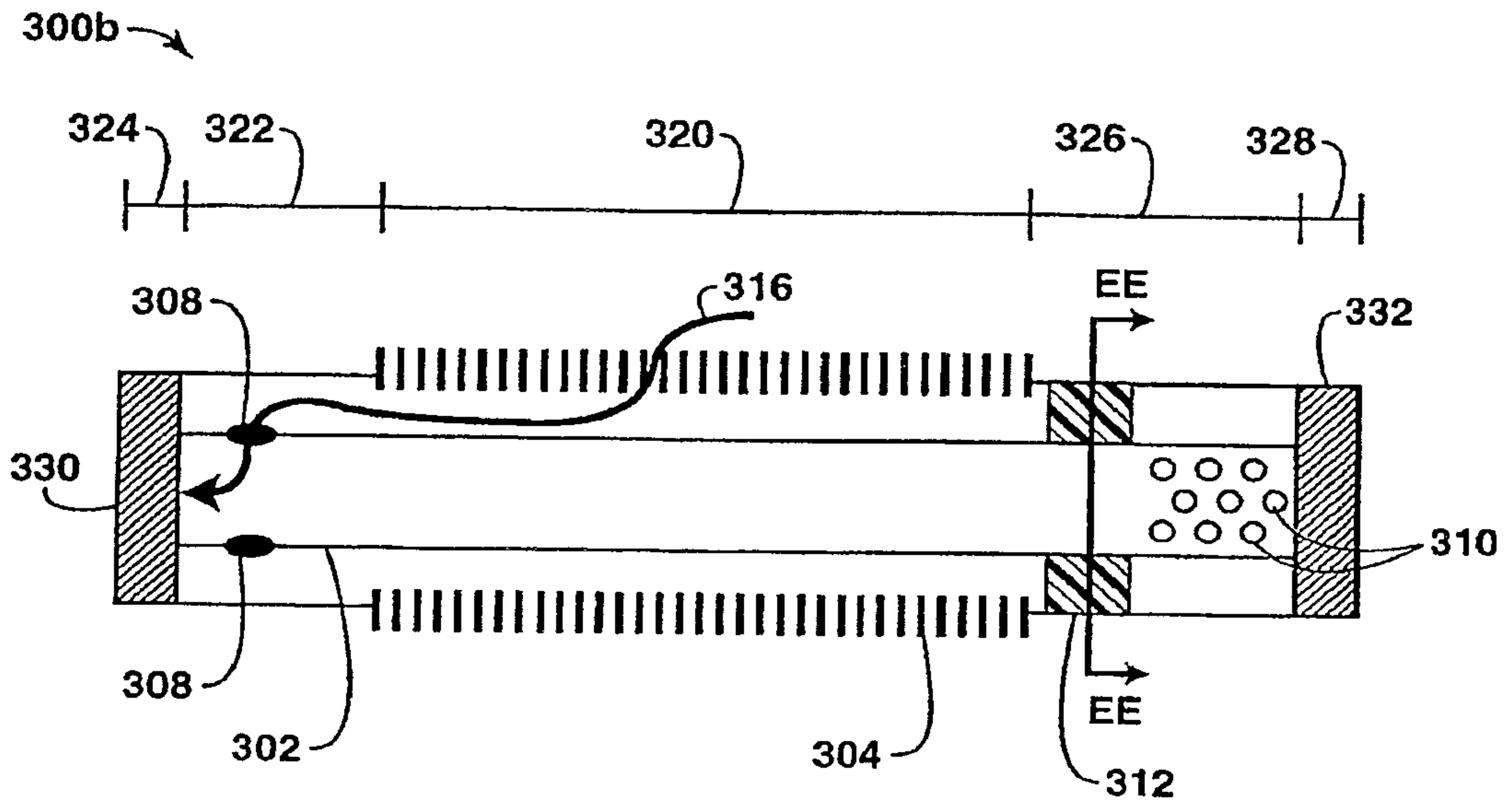

FIG. 3F

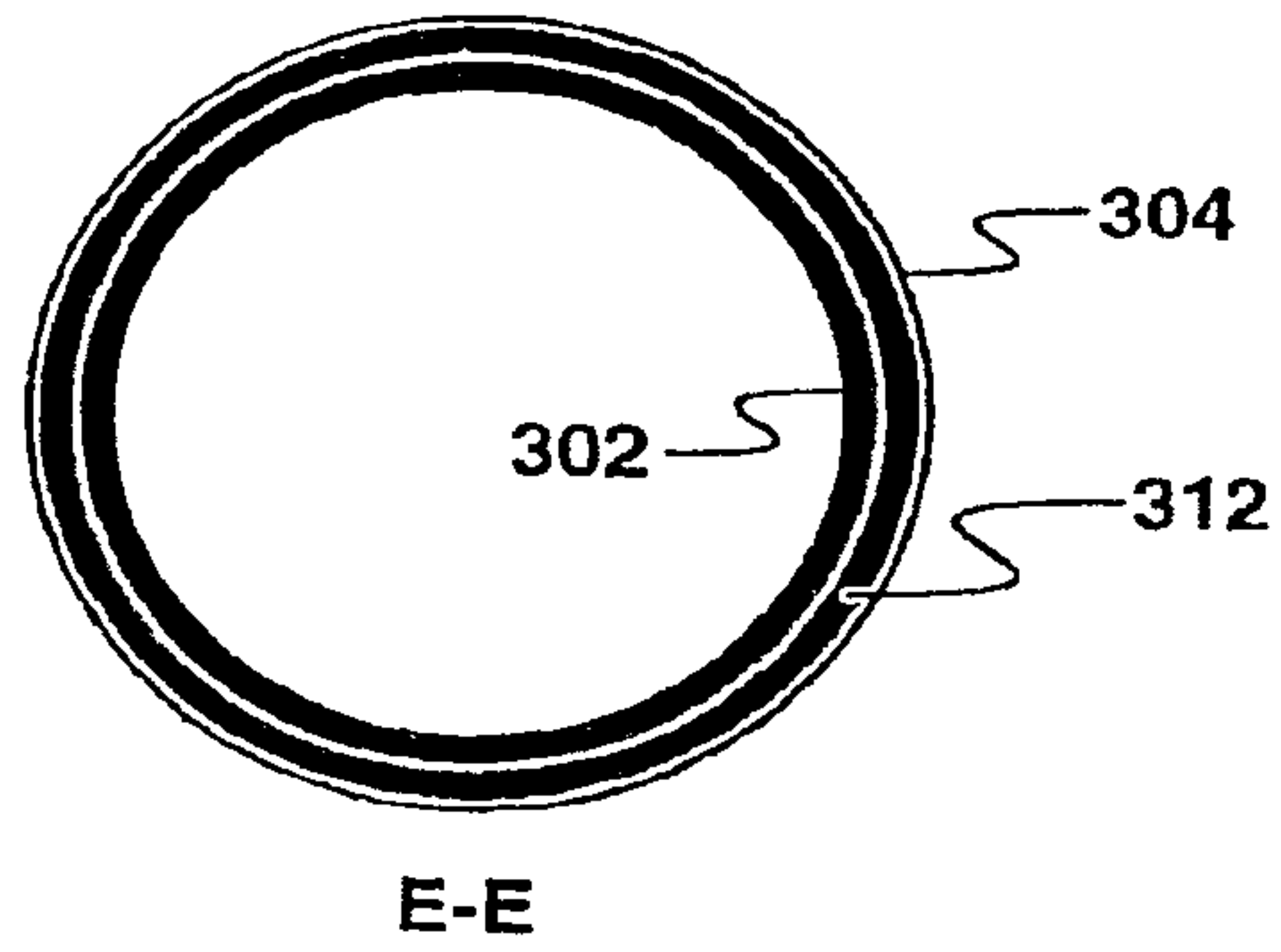

FIG. 3G

9/17

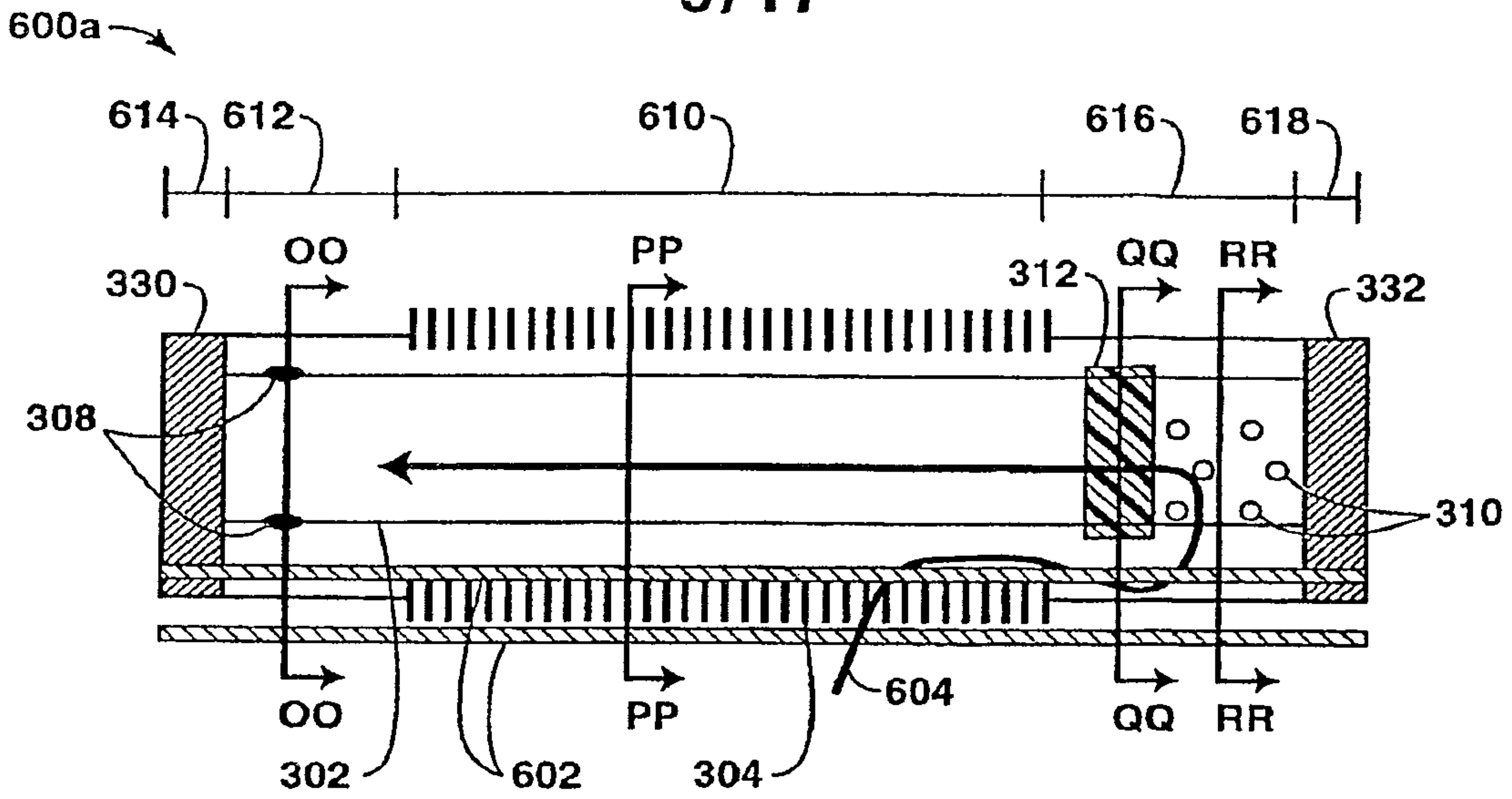
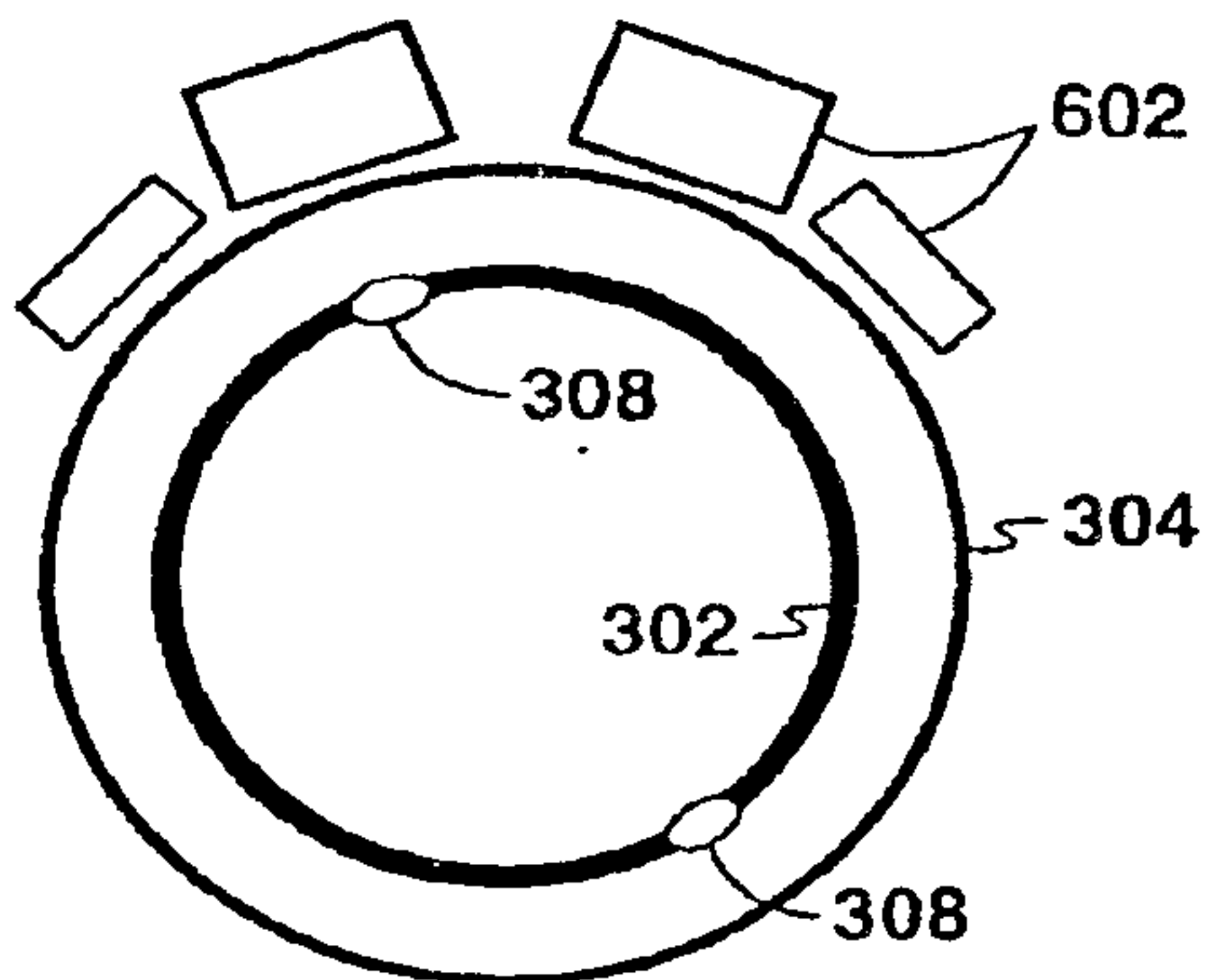
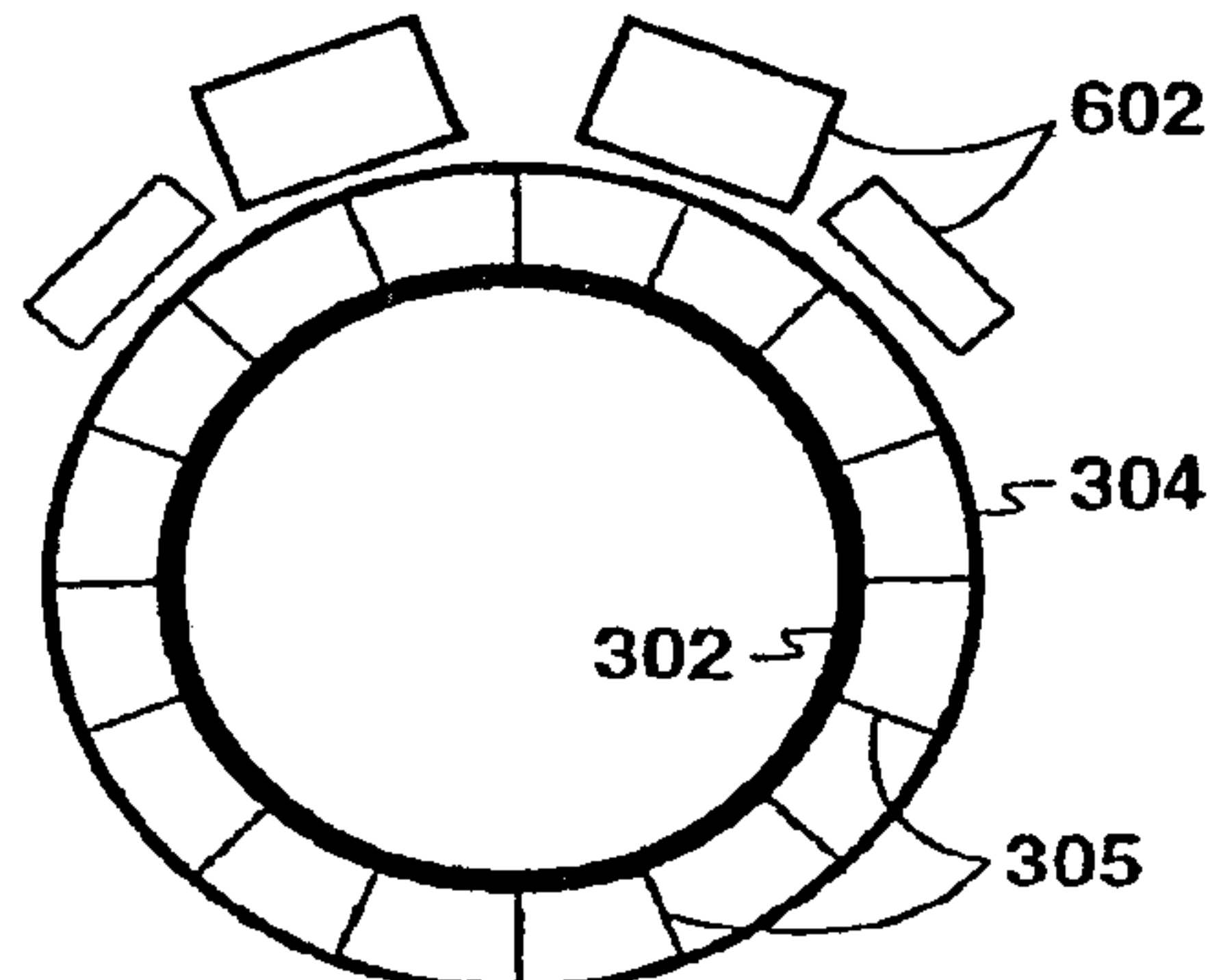

FIG. 6A



O-O

FIG. 6B



P-P

FIG. 6C

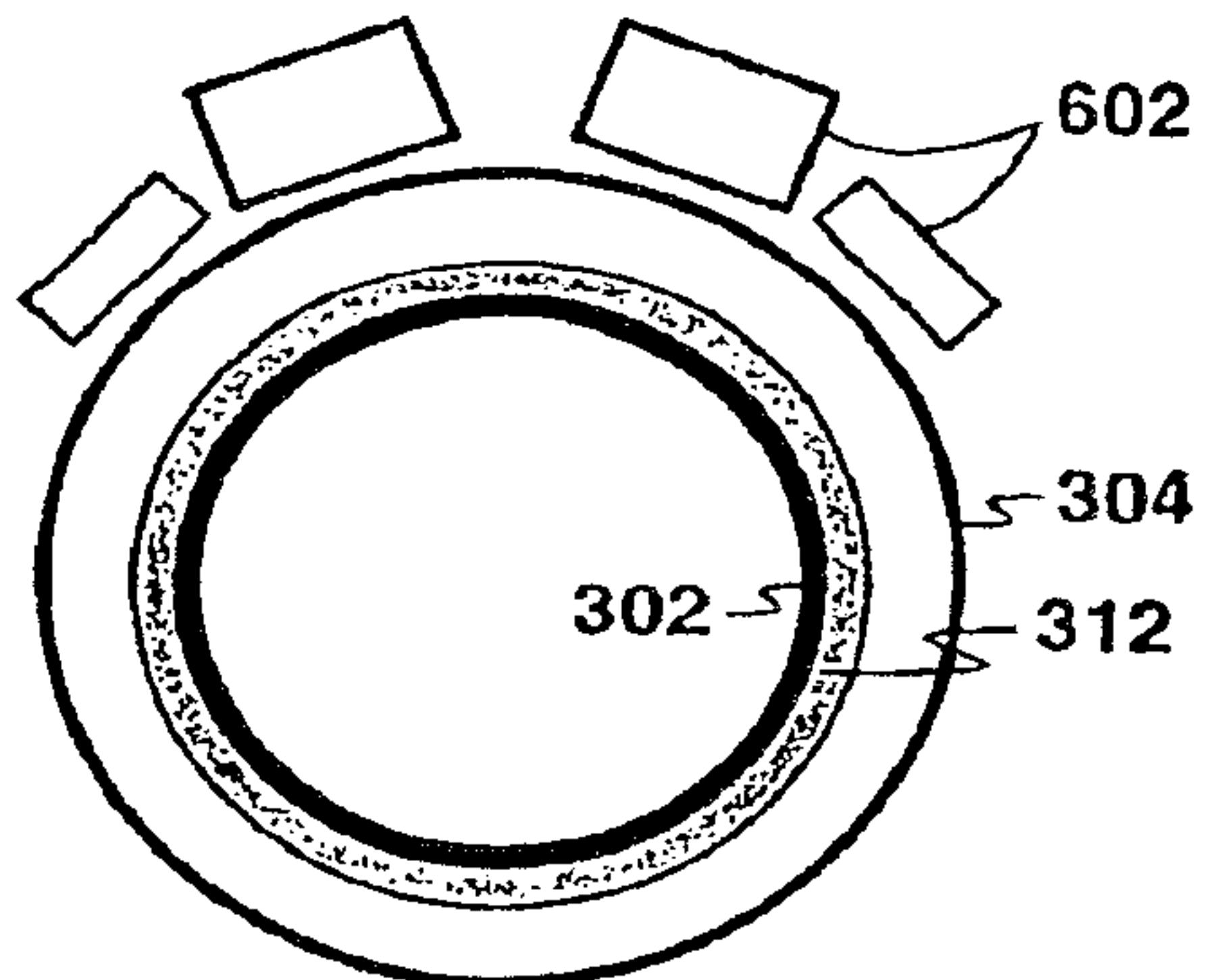

Q-Q

FIG. 6D

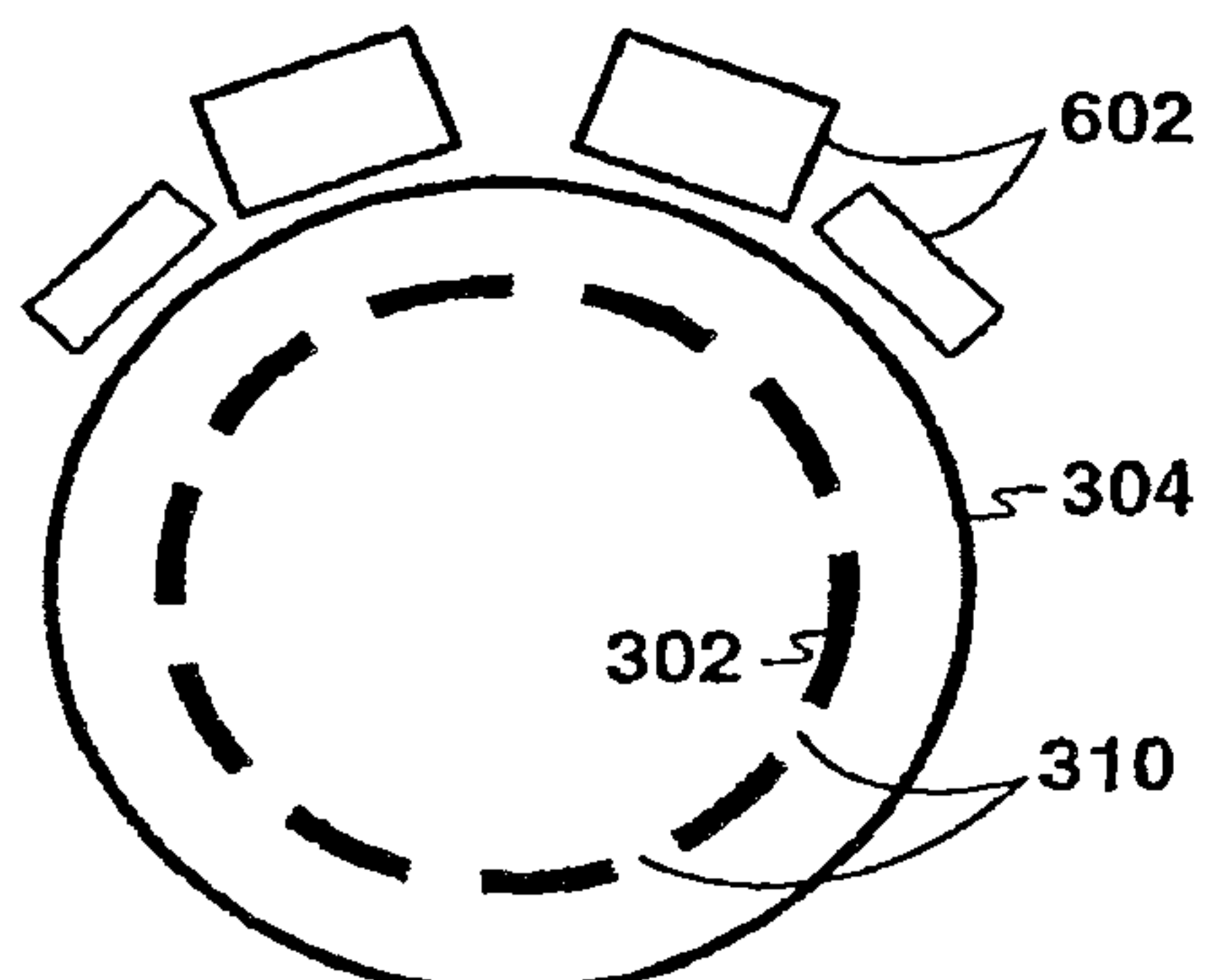

R-R

FIG. 6E

11/17

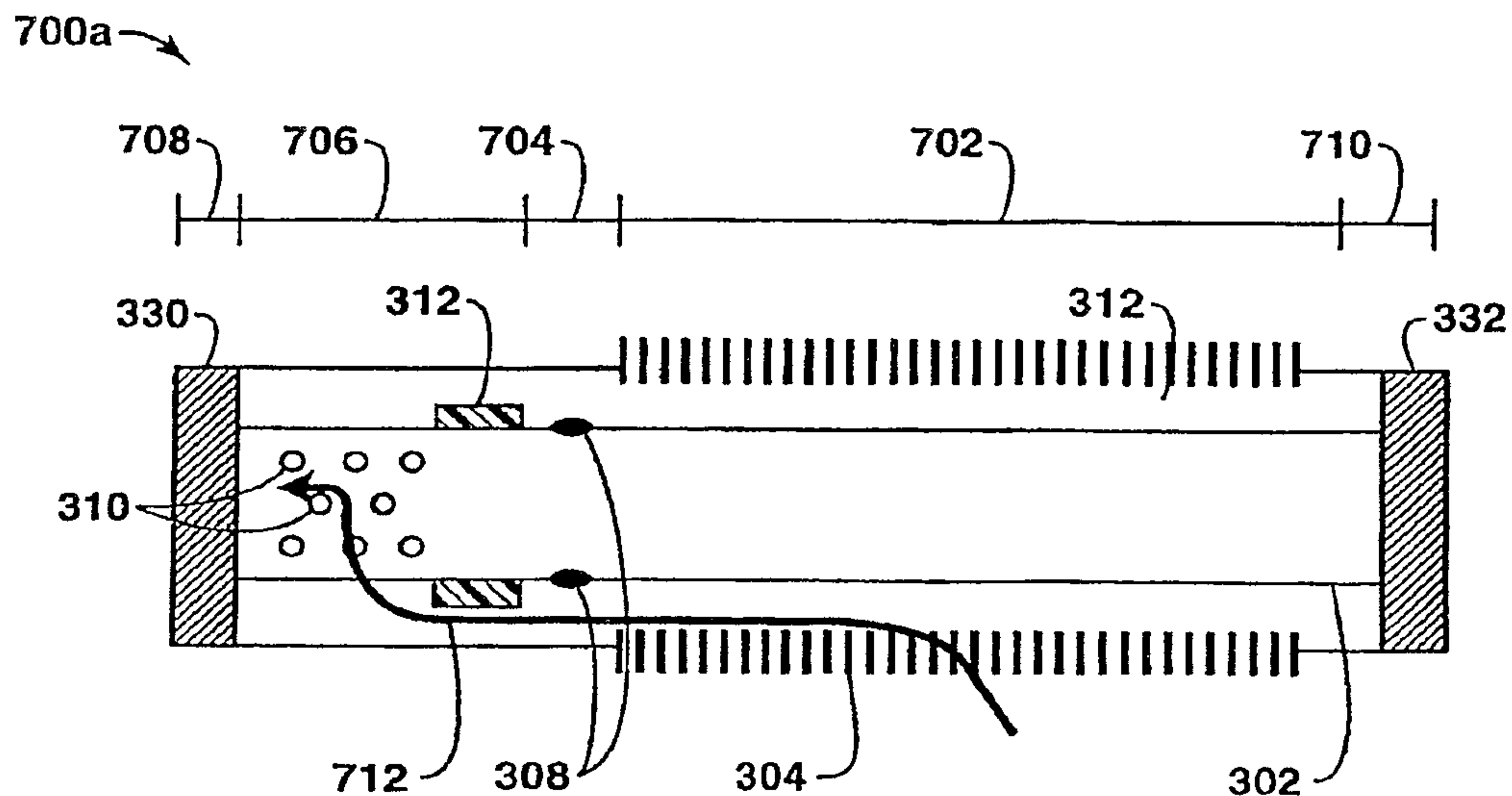

FIG. 7A

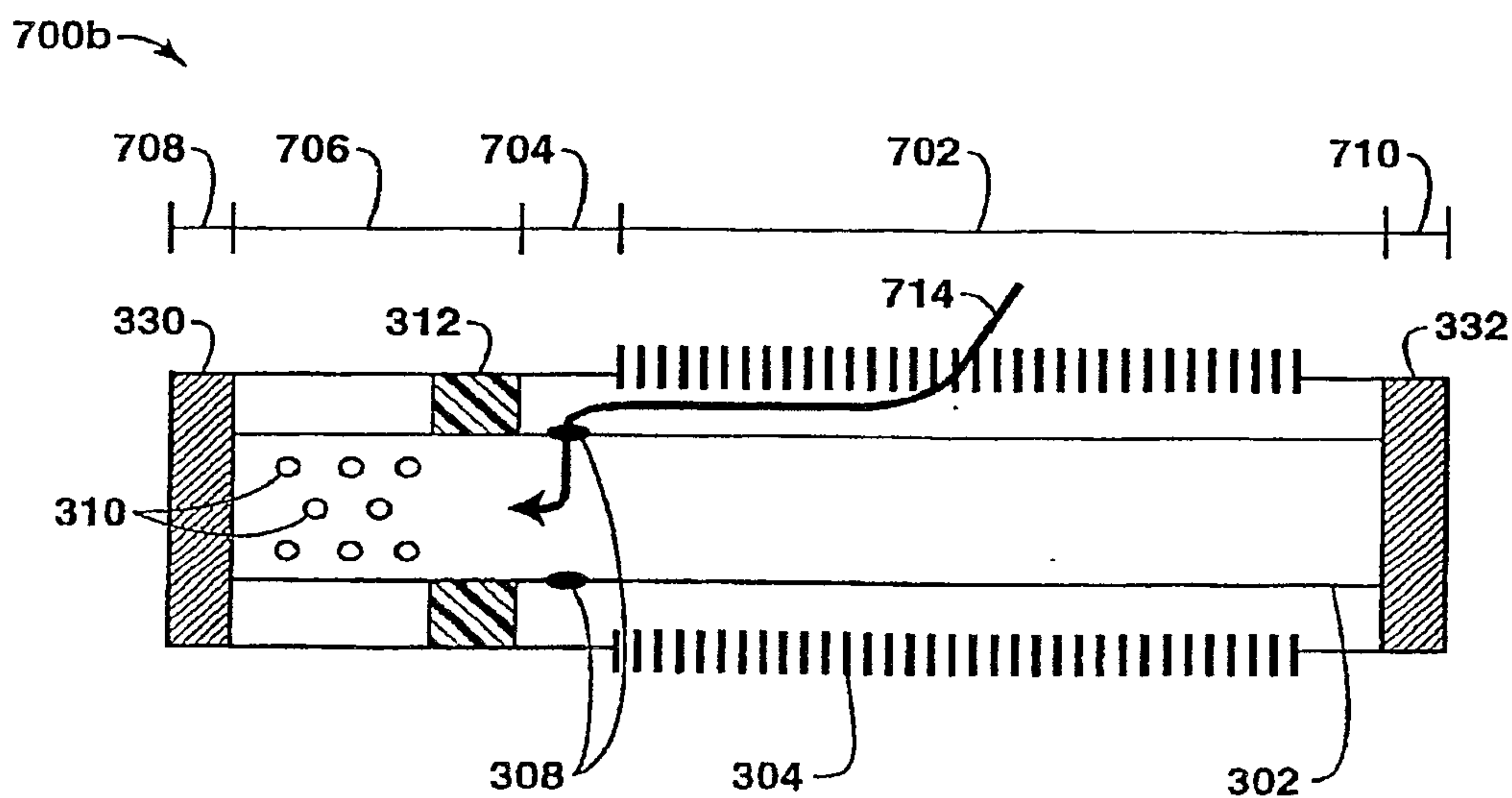

FIG. 7B

12/17

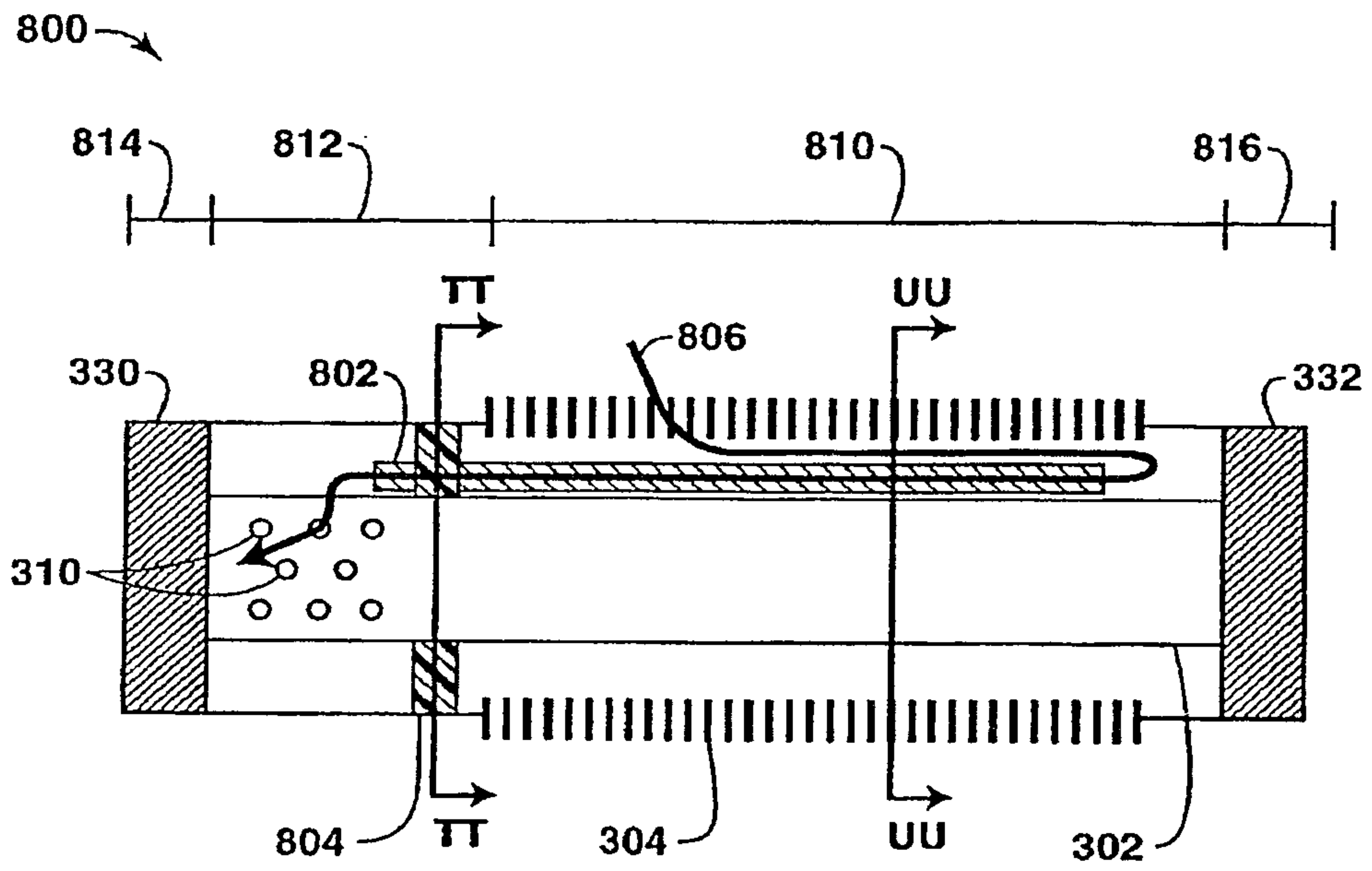

FIG. 8A

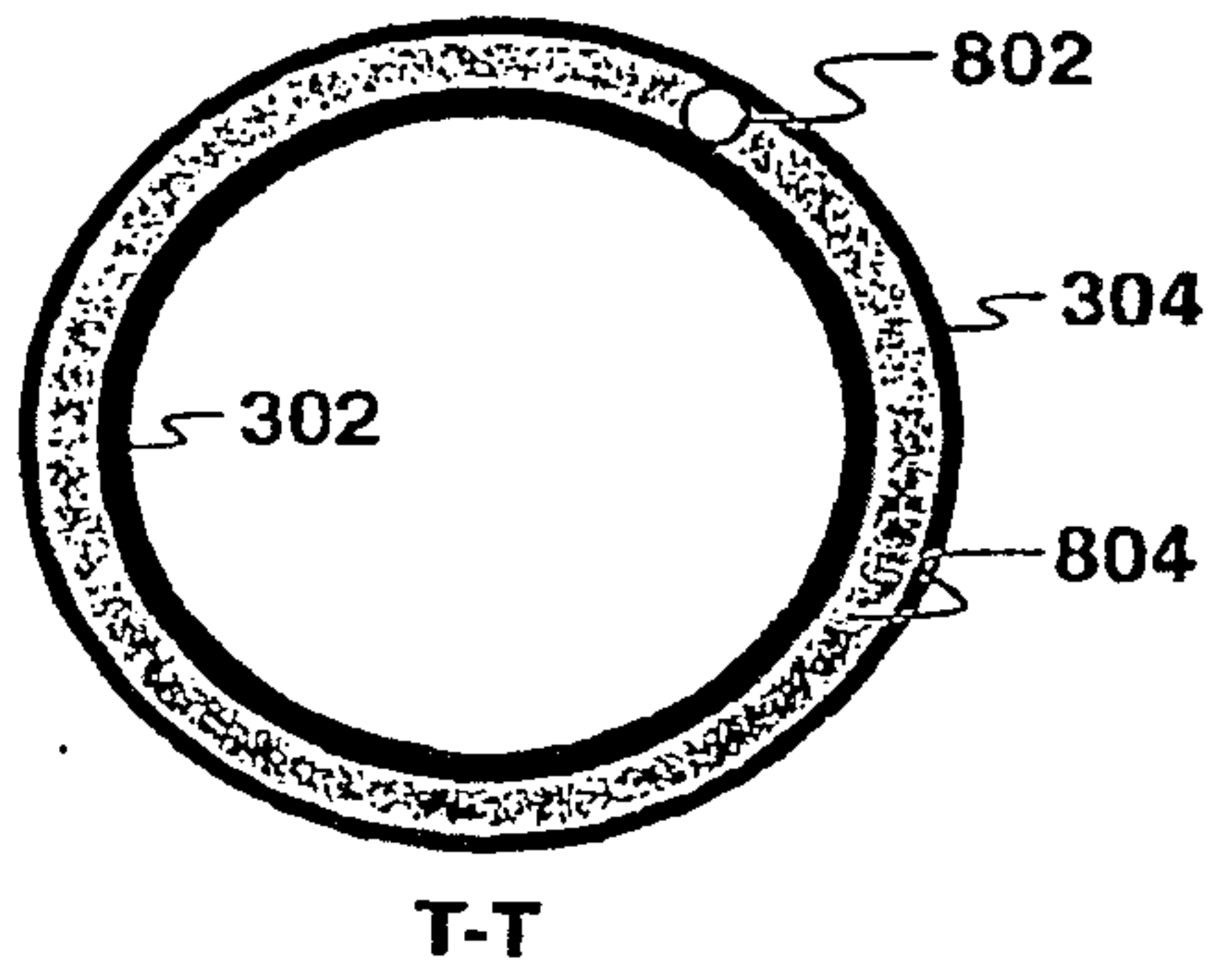

FIG. 8B

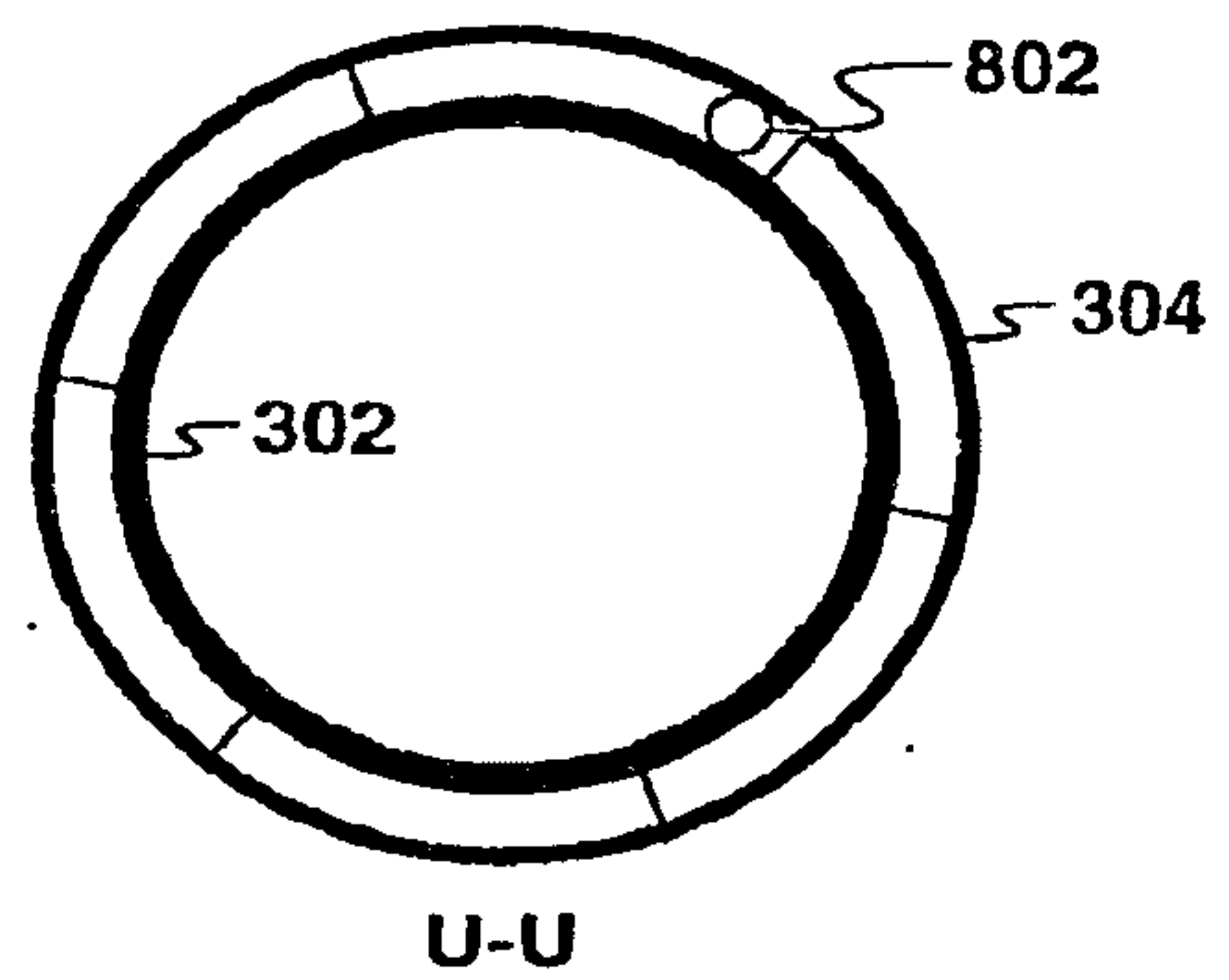

FIG. 8C

15/17

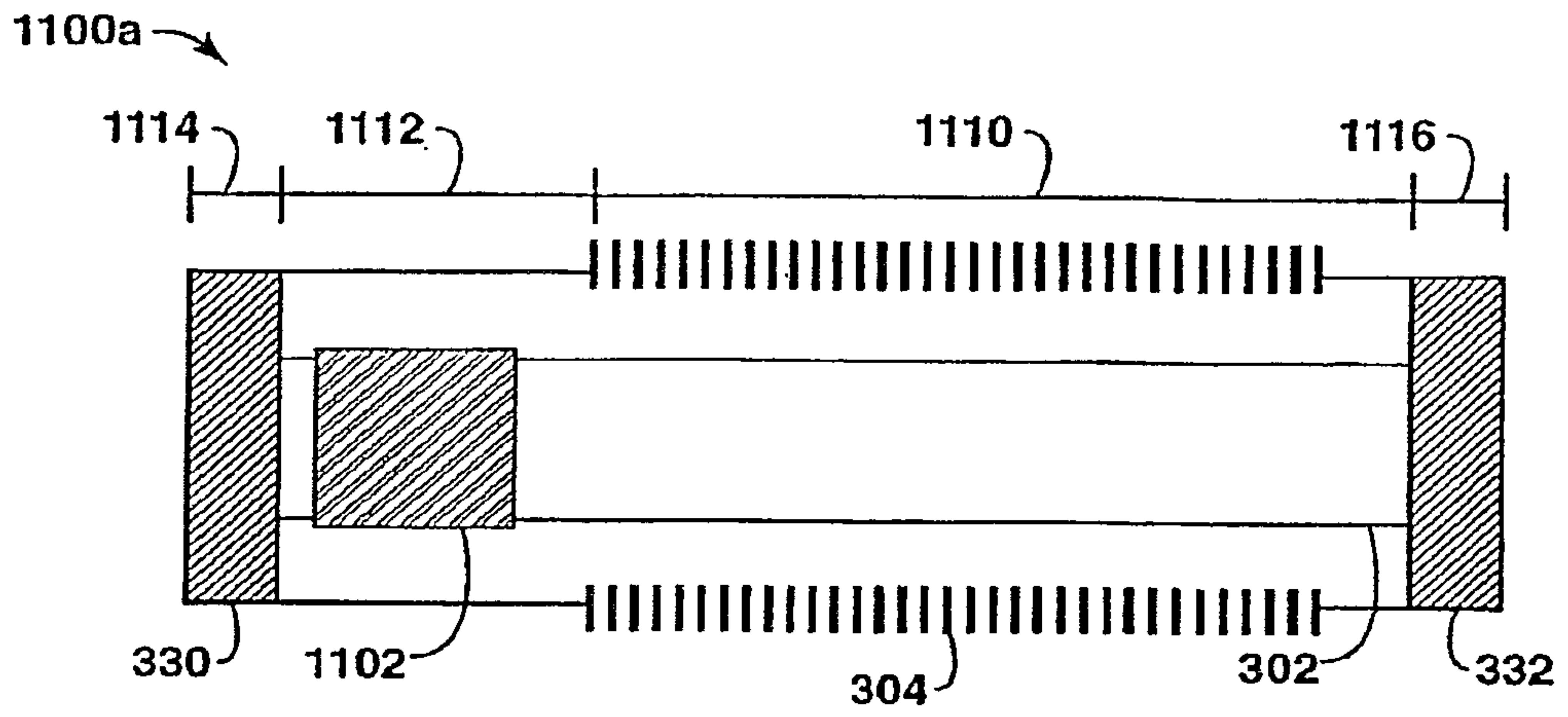

FIG. 11A

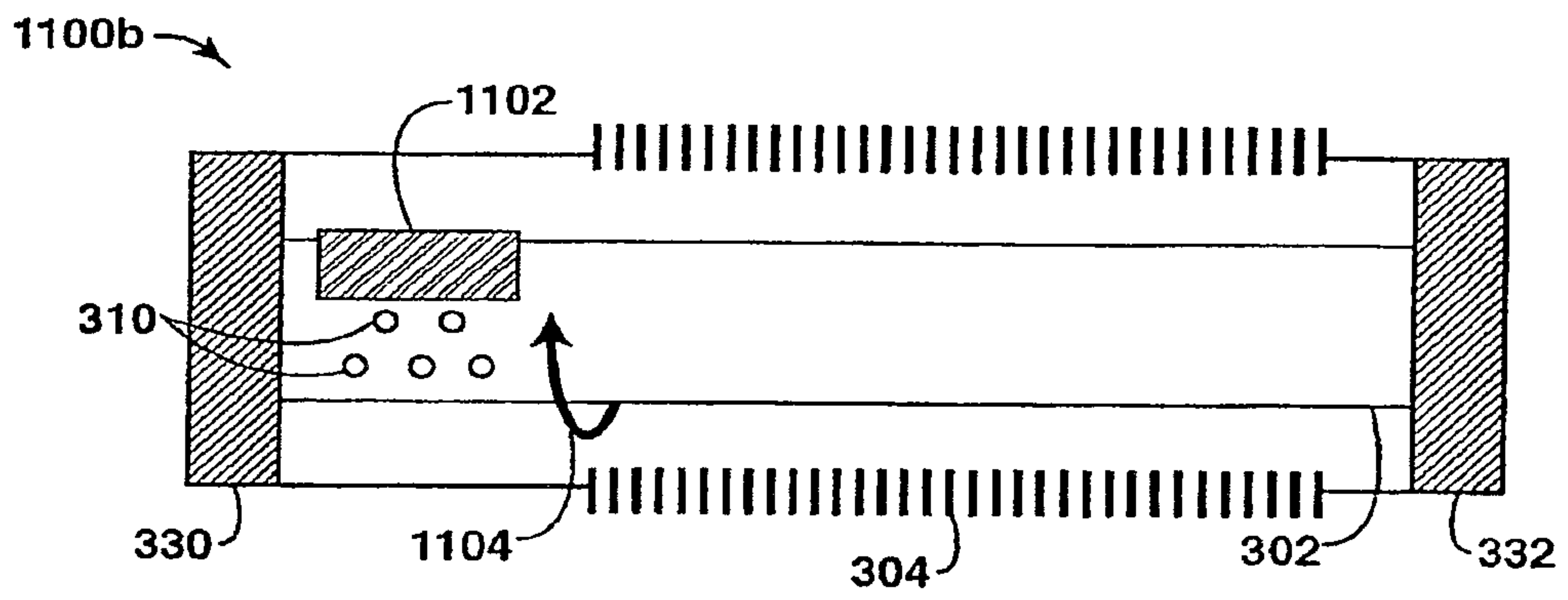

FIG. 11B

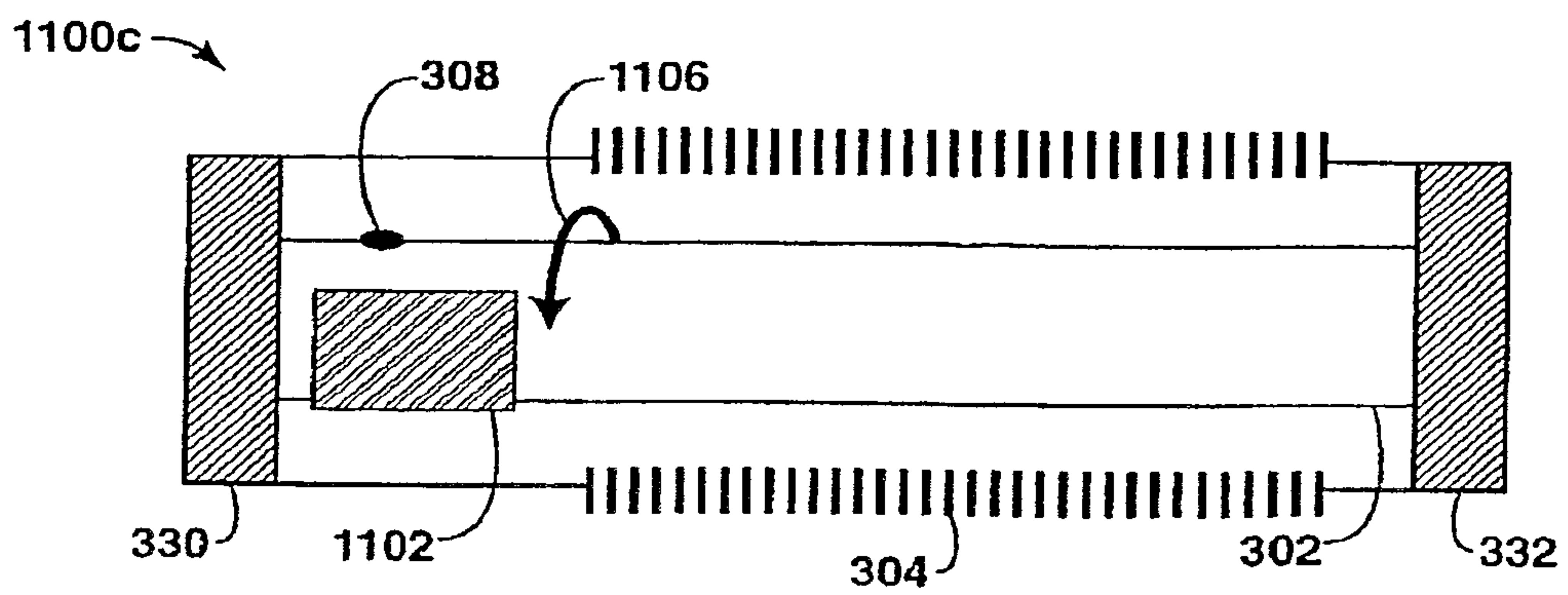

FIG. 11C

16/17

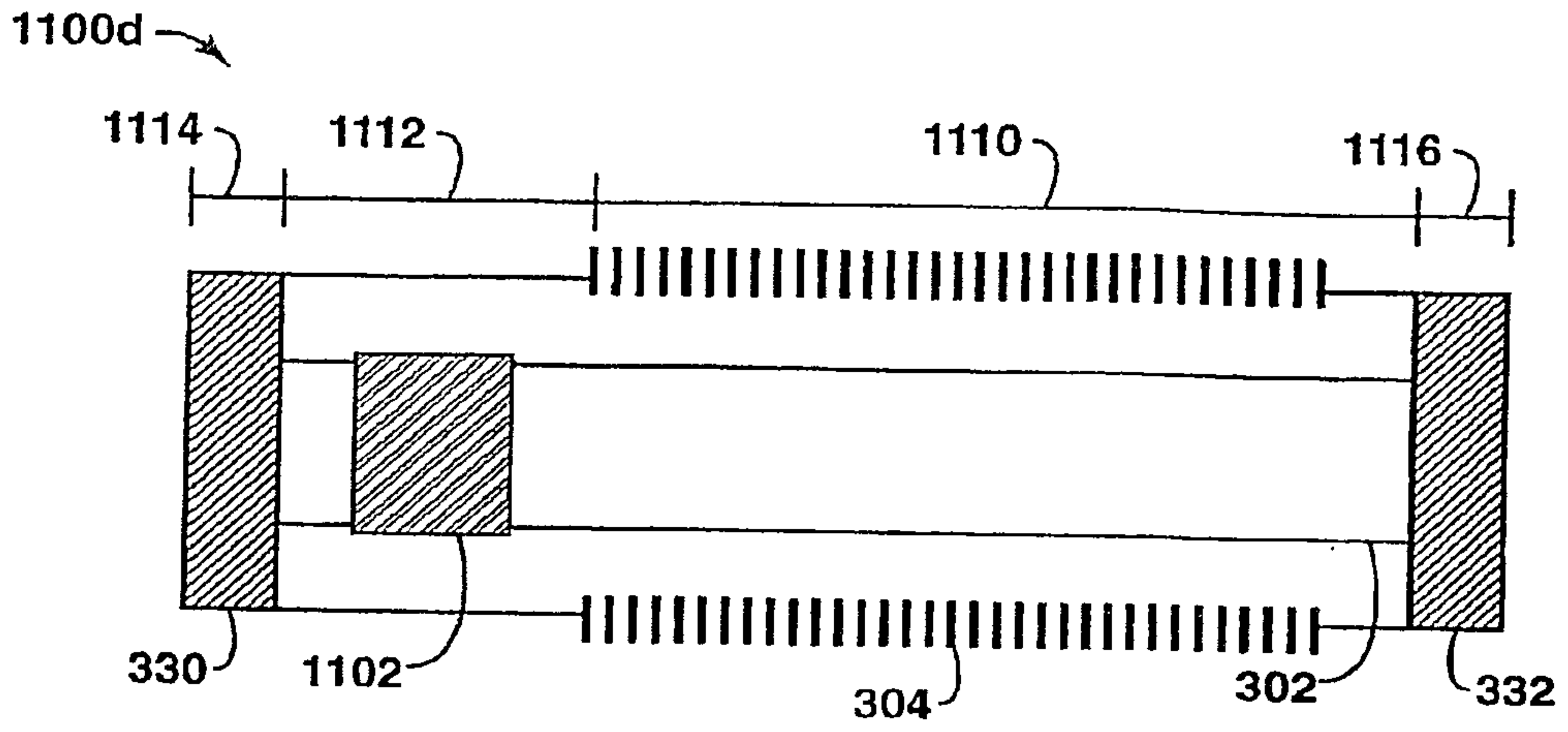

FIG. 11D

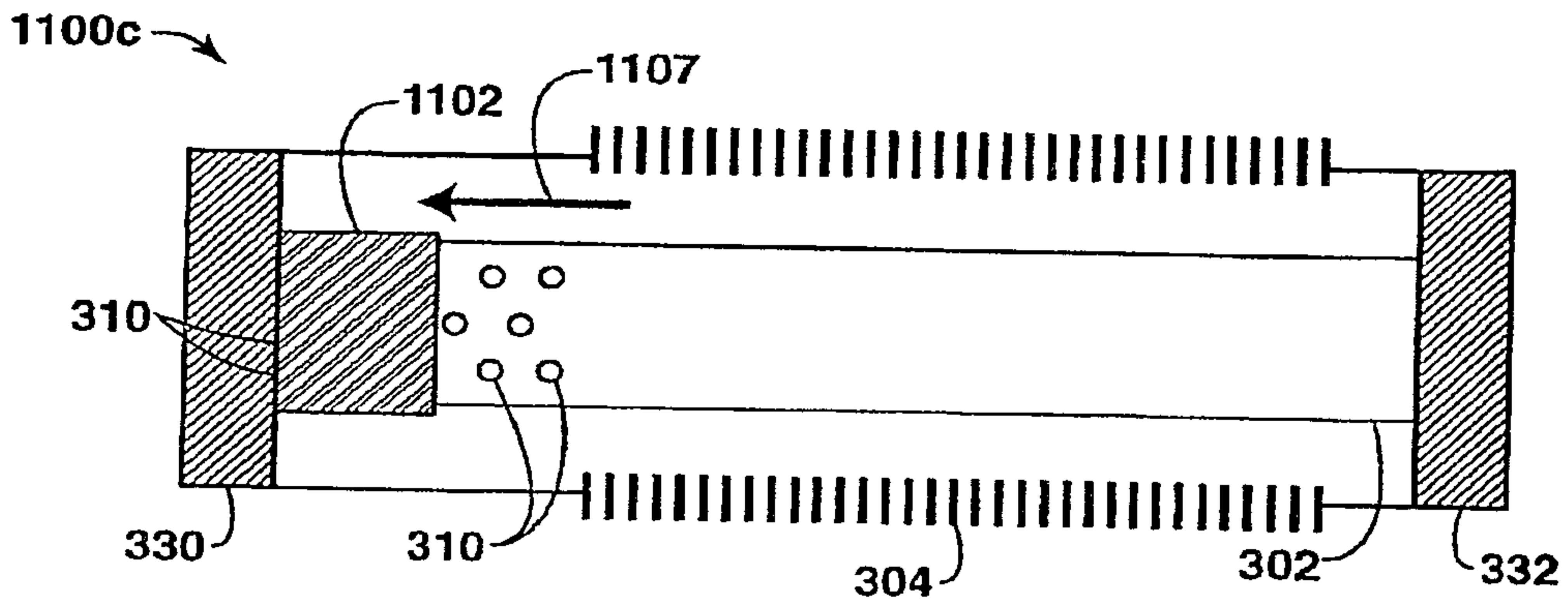

FIG. 11E

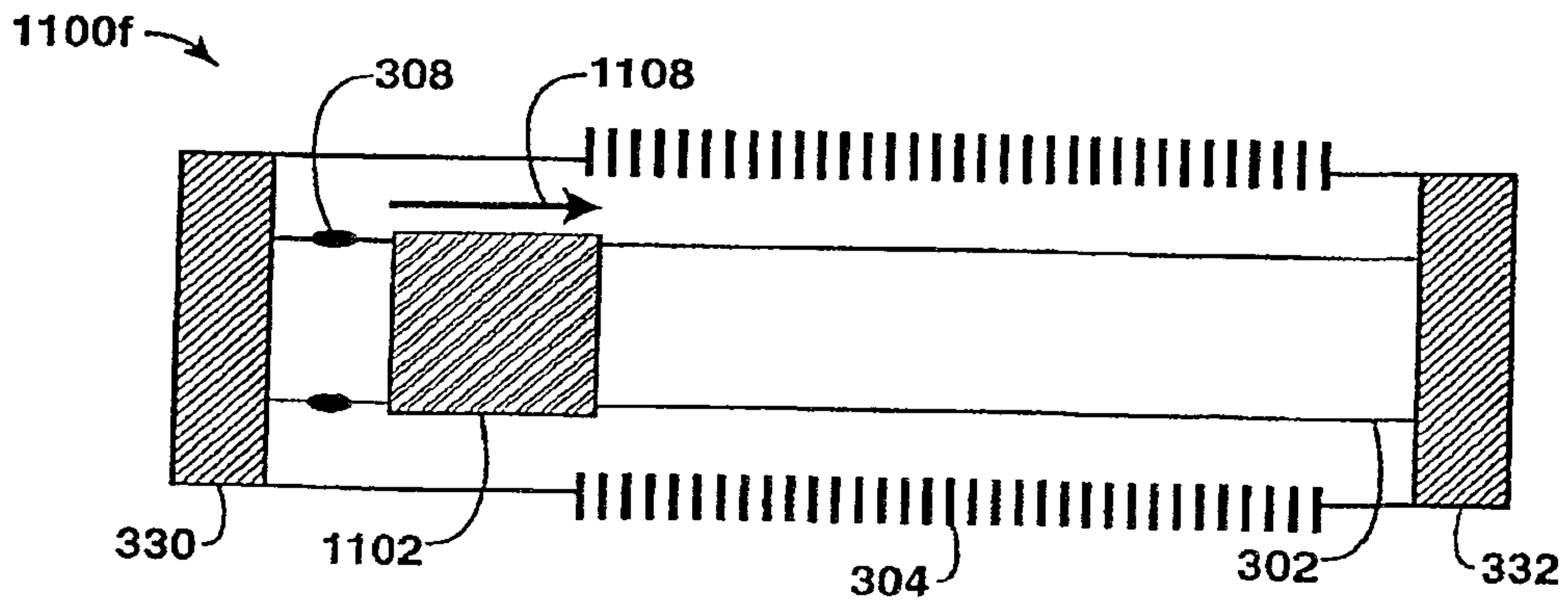

FIG. 11F