



(12) **EUROPEAN PATENT APPLICATION**

(88) Date of publication A3:
27.10.2004 Bulletin 2004/44

(51) Int Cl.7: **B21J 15/04, B21J 15/02,
B21J 15/06, B25B 27/00**

(43) Date of publication A2:
07.07.1999 Bulletin 1999/27

(21) Application number: **98123420.6**

(22) Date of filing: **09.12.1998**

(84) Designated Contracting States:
**AT BE CH CY DE DK ES FI FR GB GR IE IT LI LU
MC NL PT SE**
Designated Extension States:
AL LT LV MK RO SI

(72) Inventor: **Schwab, Manfred
549 32 Velké Porici (CZ)**

(74) Representative: **Reinhardt, Harry et al
Reinhardt & Pohlmann Partnerschaft,
Grünstrasse 1
75172 Pforzheim (DE)**

(30) Priority: **02.01.1998 CZ 754098**

(71) Applicant: **Masterfix Products B.V.
6219 NP Maastricht (NL)**

(54) **Device for clamping a stem to the traction mandrel of a riveting tool**

(57) In a device for clamping a stem to the traction mandrel of a riveting tool, the traction mandrel has a traction sleeve (11) loosely fitted in the enclosing sleeve (12) and mutually secured with the enclosing sleeve against axial shifting and turning. Between the enclosing sleeve and the peripheral recess in the traction sleeve (11) there is a compression spring (10). The traction sleeve (11) has an inner thread, onto which is screwed the stem (1), whose collar has at least one flattened

plane on its outer circumference corresponding to an inner peripheral surface of the adjacent part of the enclosing sleeve (12). The device is fitted together with the traction mandrel (13) in the nozzle (5) of the riveting tool, wherein the nozzle has a passage opening in the area of the enclosing sleeve (12). Without the use of a tightening instrument as for example a key, it is possible to change easily and very quickly the mandrels for rivets in the riveting tool.

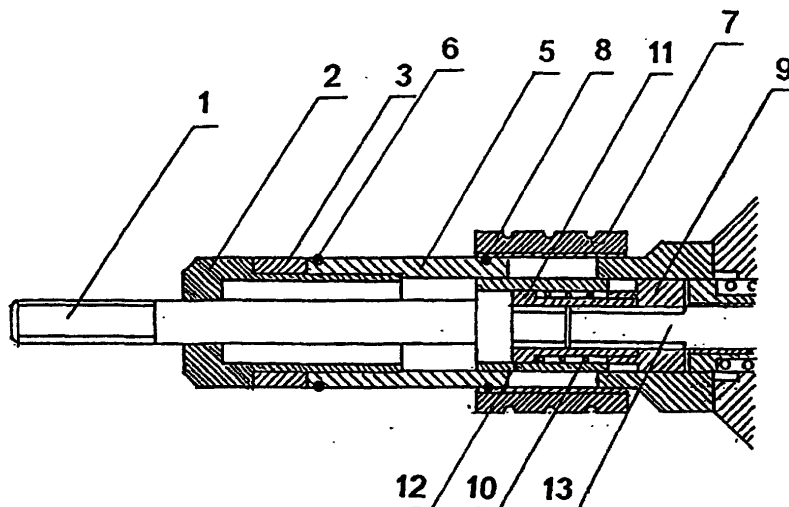

FIG.1



European Patent Office

EUROPEAN SEARCH REPORT

Application Number
EP 98 12 3420

DOCUMENTS CONSIDERED TO BE RELEVANT			
Category	Citation of document with indication, where appropriate, of relevant passages	Relevant to claim	CLASSIFICATION OF THE APPLICATION (Int.Cl.6)
A	EP 0 325 669 A (LOBSTER TOOL CO LTD) 2 August 1989 (1989-08-02) * column 4, line 51 - column 5, line 19 * * column 6, lines 52-55 * * column 7, lines 29-33 * * column 9, lines 36-41; figures 1,5,11 * -----	1	B21J15/04 B21J15/02 B21J15/06 B25B27/00
			TECHNICAL FIELDS SEARCHED (Int.Cl.6)
			B21J B25B B25F
The present search report has been drawn up for all claims			
Place of search		Date of completion of the search	Examiner
Munich		3 September 2004	Augé, M
<p>CATEGORY OF CITED DOCUMENTS</p> <p>X : particularly relevant if taken alone Y : particularly relevant if combined with another document of the same category A : technological background O : non-written disclosure P : intermediate document</p> <p>T : theory or principle underlying the invention E : earlier patent document, but published on, or after the filing date D : document cited in the application L : document cited for other reasons & : member of the same patent family, corresponding document</p>			

EPO FORM 1503 03.82 (P04C01)

**ANNEX TO THE EUROPEAN SEARCH REPORT
ON EUROPEAN PATENT APPLICATION NO.**

EP 98 12 3420

This annex lists the patent family members relating to the patent documents cited in the above-mentioned European search report. The members are as contained in the European Patent Office EDP file on
The European Patent Office is in no way liable for these particulars which are merely given for the purpose of information.

03-09-2004

Patent document cited in search report		Publication date	Patent family member(s)	Publication date
EP 0325669	A	02-08-1989	EP 0325669 A1	02-08-1989
			DE 3866228 D1	19-12-1991
			US 4821555 A	18-04-1989

EPO FORM P0459

For more details about this annex : see Official Journal of the European Patent Office, No. 12/82