



(12) **EUROPEAN PATENT APPLICATION**

(43) Date of publication:  
**14.01.2009 Bulletin 2009/03**

(51) Int Cl.:  
**A62B 7/04 (2006.01)**

(21) Application number: **07112051.3**

(22) Date of filing: **09.07.2007**

(84) Designated Contracting States:  
**AT BE BG CH CY CZ DE DK EE ES FI FR GB GR HU IE IS IT LI LT LU LV MC MT NL PL PT RO SE SI SK TR**  
 Designated Extension States:  
**AL BA HR MK RS**

(71) Applicant: **Air For Life Ltd.**  
**Tel Aviv 67891 (IL)**

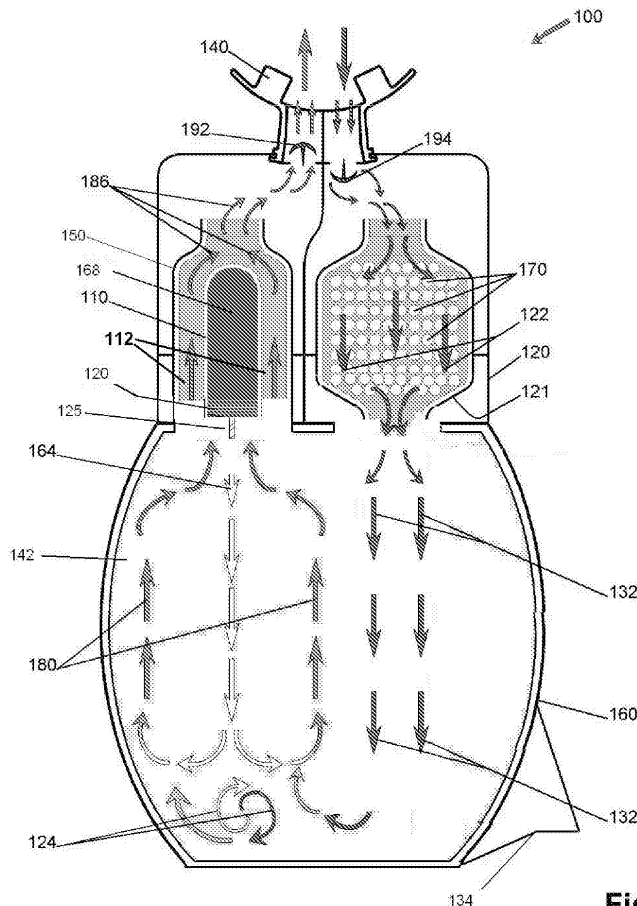
(72) Inventor: **Shahaf, Daniel**  
**15130, Degania Bet (IL)**

(74) Representative: **Sarpi, Maurizio**  
**Studio Ferrario**  
**Via Collina, 36**  
**00187 Roma (RM) (IT)**

(54) **Protected breathing device**

(57) An emergency escape breathing device (100), comprising: a canister housing (120) containing a CO<sub>2</sub> absorbing canister (121) and an oxygen bottle (110) configured to contain compressed oxygen, an oxygen re-

lease regulator configured to release of the compressed oxygen at a constant rate during use of the emergency escape breathing device, the oxygen release regulator being substantially contained within the oxygen bottle, a contour lung (160) and a mouthpiece (140).



**Fig. 5**

**Description**

## FIELD AND BACKGROUND OF THE INVENTION

**[0001]** The present invention relates to emergency escape breathing devices. More specifically the present invention relates to emergency escape breathing devices having protected oxygen regulators and large counter lung capacities.

**[0002]** An emergency escape breathing device supplies recycled purified air to a user by adsorbing CO<sub>2</sub> (carbon dioxide) from expired air and enriching the air with O<sub>2</sub> (oxygen) in a closed loop system. Emergency escape breathing devices provide purified air to a user for a limited time during escape from a hostile environment, for example a smoke-filled building posing imminent danger to breathing.

**[0003]** Existing emergency escape breathing devices have compressed, dry or liquid, O<sub>2</sub> in a bottle that once activated, provides a constant flow of approximately 1.2 - 1.5 liters of O<sub>2</sub> per minute throughout use of the emergency escape breathing device. The key to providing the O<sub>2</sub> at this constant rate is a regulator on the O<sub>2</sub> bottle; a sensitive part of the emergency escape breathing device that can malfunction due to knocks or bangs during storage or use of the emergency escape breathing device.

**[0004]** US Patents 7,140,591, and 6,997,348 (Droppleman), the entirety of which are incorporated herein by reference, teach emergency escape breathing devices having a vulnerable O<sub>2</sub> regulator which, during storage for a period of up to 15 years, or during, use may be knocked or banged, causing malfunction. A malfunctioning O<sub>2</sub> regulator will deny the user purified air in a hostile environment and may result in death of the user.

**[0005]** In addition, the above-noted patents have an O<sub>2</sub> bottle that may malfunction due to the impact of being dropped. Further, if the O<sub>2</sub> bottle heats up due to the high temperature of the environment the user may get a burn upon touching the O<sub>2</sub> bottle.

**[0006]** Another component of the emergency escape breathing device is a counter lung, a reservoir configured to contain purified air and O<sub>2</sub>. A large counter lung allows the user continued breathing for a significant period of time after the O<sub>2</sub> from the O<sub>2</sub> bottle has been exhausted. Large counter lungs, however, add considerable weight to the rebreather, hindering a fast escape from the hostile environment. To cut down on weight counter lungs are configured with small volumes, an example of which is seen in US Patent 4,440,163 (Spergel), the disclosure of which is incorporated herein by reference, thereby reducing the amount of purified air than can be utilized following exhaustion of the O<sub>2</sub> stream.

**[0007]** There is thus a widely recognized need for, and it would be highly advantageous to have, an emergency escape breathing device devoid of the above limitations.

## SUMMARY OF THE INVENTION

**[0008]** The present invention successfully addresses at least some of the shortcomings of the prior art with an emergency escape breathing device having an O<sub>2</sub> regulator that is fully contained within the O<sub>2</sub> bottle, thereby protecting the O<sub>2</sub> regulator from knocks and bangs during storage or use, thereby substantially preventing malfunction.

**[0009]** In additional embodiments, the O<sub>2</sub> bottle is contained in at least one housing that protects the O<sub>2</sub> bottle against impact and/or heat buildup.

**[0010]** In addition, the present invention includes a compact counter lung that assumes large volume in the expanded configuration, allowing the counter lung to assume a large inflated volume while conserving space and weight both in the unexpanded and expanded configurations.

**[0011]** According to one aspect of an embodiment of the invention, there is provided an emergency escape breathing device, comprising: an oxygen bottle configured to contain compressed oxygen, an oxygen release regulator that releases the compressed oxygen at a constant rate during use of the emergency escape breathing device, the oxygen release regulator being substantially contained within the oxygen bottle.

**[0012]** In embodiments, the oxygen bottle comprises a substantially monotonous configuration.

**[0013]** In embodiments, the oxygen bottle is contained within a protective housing.

**[0014]** In embodiments, the protective housing is configured to protect the oxygen bottle against at least one of: impact, and heat buildup.

**[0015]** In embodiments, the oxygen bottle is configured to contain dry oxygen.

**[0016]** In embodiments, the oxygen release regulator is configured to release the dry oxygen at the constant rate.

**[0017]** In embodiments, the device includes a counter lung comprising a chamber, the chamber in an unexpanded configuration being enclosed by at least two substantially parallel walls and a perimeter connecting the at least two substantially parallel walls, the perimeter including at least one fold that substantially extends into the chamber.

**[0018]** In embodiments, when the chamber is in an expanded configuration, the at least one fold substantially unfolds and at least a portion of the two walls diverge. In embodiments, the device includes forward and backpass valves operatively associated with said counter lung.

**[0019]** In embodiments, the forward and backpass valves promote a circular airflow within said device.

**[0020]** In embodiments, the regulator includes a demand valve that releases a burst of oxygen in response to light pressure.

**[0021]** In embodiments, the demand valve releases the burst of oxygen at a faster rate than the release of oxygen by the regulator.

**[0022]** In embodiments, the demand valve releases the oxygen in response to pressure from the counter lung.

**[0023]** According to another aspect of an embodiment of the invention, there is provided an emergency escape breathing device, comprising: a counter lung comprising a chamber, the chamber in an unexpanded configuration being enclosed by at least two substantially parallel walls and a perimeter connecting the at least two substantially parallel walls, the perimeter including at least one fold that substantially extends into the chamber.

**[0024]** In embodiments, when the chamber is in an expanded configuration, the at least one fold substantially unfolds and at least a portion of the two walls diverge.

**[0025]** According to a still further aspect of an embodiment of the invention, there is provided an emergency escape breathing device, comprising: an oxygen bottle configured to contain compressed oxygen, an oxygen release regulator configured to release the compressed oxygen at a constant rate during use of the emergency escape breathing device, the oxygen release regulator being substantially contained within the oxygen bottle, and a counter lung comprising a chamber, the chamber in an unexpanded configuration being enclosed by at least two substantially parallel walls and a perimeter connecting the at least two substantially parallel walls, the perimeter including at least one fold that substantially extends into the chamber.

**[0026]** In embodiments, when the chamber is in an expanded configuration, the at least one fold substantially unfolds and at least a portion of the two walls diverge.

**[0027]** In embodiments, the oxygen bottle comprises a substantially monotonous configuration.

**[0028]** In embodiments, the oxygen bottle is contained within a protective housing.

**[0029]** In embodiments, the protective housing is configured to protect the oxygen bottle against at least one of: impact, and heat buildup.

**[0030]** The present invention successfully addresses the shortcomings of the presently known configurations by providing an emergency escape breathing device having a protected O<sub>2</sub> regulator, protected O<sub>2</sub> bottle and a compact counter lung having a large inflation volume.

**[0031]** Unless otherwise defined, all technical and scientific terms used herein have the same meaning as commonly understood by one of ordinary skill in the art to which this invention belongs. Although methods and materials similar or equivalent to those described herein can be used in the practice or testing of the present invention, suitable methods and materials are described below. In case of conflict, the patent specification, including definitions, will control. In addition, the materials, methods, and examples are illustrative only and not intended to be limiting.

**[0032]** As used herein, the terms "comprising" and "including" or grammatical variants thereof are to be taken as specifying the stated features, integers, steps or components but do not preclude the addition of one or more additional features, integers, steps, components or

groups thereof. This term encompasses the terms "consisting of" and "consisting essentially of".

**[0033]** The phrase "consisting essentially of" or grammatical variants thereof when used herein are to be taken as specifying the stated features, integers, steps or components but do not preclude the addition of one or more additional features, integers, steps, components or groups thereof but only if the additional features, integers, steps, components or groups thereof do not materially alter the basic and novel characteristics of the claimed composition, device or method.

**[0034]** The term "method" refers to manners, means, techniques and procedures for accomplishing a given task including, but not limited to, those manners, means, techniques and procedures either known to, or readily developed from known manners, means, techniques and procedures by practitioners of the engineering arts.

#### BRIEF DESCRIPTION OF THE DRAWINGS

**[0035]** The invention is herein described, by way of example only, with reference to the accompanying drawings.

**[0036]** With specific reference now to the drawings in detail, it is stressed that the particulars shown are by way of example and for purposes of illustrative discussion of the preferred embodiments of the present invention only, and are presented in the cause of providing what is believed to be the most useful and readily understood description of the principles and conceptual aspects of the invention. In this regard, no attempt is made to show structural details of the invention in more detail than is necessary for a fundamental understanding of the invention, the description taken with the drawings making apparent to those skilled in the art how the several forms of the invention may be embodied in practice.

**[0037]** In the drawings:

Figure 1 is a cross sectional view of an O<sub>2</sub> bottle housing, according to embodiments of the invention; Figure 2 is a cross sectional view of an O<sub>2</sub> bottle and regulator, according to embodiments of the invention;

Figures 3-4 are a cross sectional view and plan view, respectively, of a counter lung, according to embodiments of the invention; and

Figure 5 is a schematic drawing of an emergency escape breathing device, according to embodiments of the invention.

#### DESCRIPTION OF THE PREFERRED EMBODIMENTS

**[0038]** The principles and operation of an emergency escape breathing device having a protected O<sub>2</sub> regulator and a compact counter lung having a large inflation volume, according to the present invention, may be better understood with reference to the drawings and accompanying descriptions.

**[0039]** Before explaining at least one embodiment of the invention in detail, it is to be understood that the invention is not limited in its application to the details of construction and the arrangement of the components set forth in the following description or illustrated in the drawings. The invention is capable of other embodiments or of being practiced or carried out in various ways. Also, it is to be understood that the phraseology and terminology employed herein is for the purpose of description and should not be regarded as limiting.

**[0040]** Referring now to the drawings; Figure 1 shows a protective O<sub>2</sub> bottle housing 157 that substantially surrounds an O<sub>2</sub> bottle 110, shown in Figure 2. O<sub>2</sub> bottle 110 has a reservoir containing compressed dry O<sub>2</sub> and a regulator 153 that is submerged within, and hence substantially protected by, O<sub>2</sub> bottle 110. Submerged regulator 153 is substantially protected from damage due to bangs and bumps for example during a long regulator storage period, for example 10 to 15 years noted above, or during use.

**[0041]** In alternative embodiments, O<sub>2</sub> bottle 110 is configured to contain a reservoir of compressed liquid O<sub>2</sub> and regulator 153 is configured to release compressed liquid O<sub>2</sub> at a constant rate.

**[0042]** In embodiments, O<sub>2</sub> bottle 110 has a substantially monotonous configuration; the term "substantially monotonous" meaning herein, that the diameter of O<sub>2</sub> bottle 110 comprises a cylinder having substantially the same cross sectional diameter from at least mid cylinder to regulator 153. In this manner O<sub>2</sub> bottle 110 has a substantially robust configuration that prevents damage from impact.

**[0043]** Regulator 153, as noted above, releases a stream of O<sub>2</sub> at a rate of about approximately 1.2 - 1.5 liters of O<sub>2</sub> per minute, although other rates of release are contemplated as well.

**[0044]** Additionally, regulator 153 includes a demand valve 125, comprising a post connected to a mechanism (not shown), that functions to releases a rapid burst of O<sub>2</sub> 168 from O<sub>2</sub> bottle 110 of approximately 80 liters of O<sub>2</sub> per minute in addition to the constant release of O<sub>2</sub> 168 by regulator 153, noted above.

**[0045]** Figure 3 shows a counter lung 160 enclosing a chamber 142 having a folded portion 134. Counter lung 160 is substantially compact and lightweight. While counter lung 160 is shown as having a substantially circular perimeter, counter lung 160 optionally has other perimeter configurations, including triangular, square or other polygon shapes.

**[0046]** Figure 4 shows counter lung 160 in an expanded configuration as would be the case during use. Folded portion 134 has unfolded to increase the size of counter lung 160 to contain a volume of between 10 and 20 liters. Alternatively, folded portion 134 has unfolded to increase the size of counter lung 160 to contain a volume of between 5 and 10 liters. In further embodiments, folded portion 134 has unfolded to increase the size of counter lung 160 to contain a volume of 8.5 liters

**[0047]** Figure 5 is a schematic drawing of an emergency escape breathing device 100, also referred to as a self contained breathing apparatus (SCBA), comprising a canister housing 120 containing a CO<sub>2</sub> adsorbing canister 121.

**[0048]** CO<sub>2</sub> adsorbing canister 121 has an air flow way therethrough, the flow way containing a CO<sub>2</sub> adsorbent material 170 adapted to adsorb CO<sub>2</sub> from expired air 122.

**[0049]** CO<sub>2</sub> laden exhaled air 122 passes forward from a mouthpiece 140 through canister 121, into counter lung 160. Within canister 121, CO<sub>2</sub> molecules, primarily in the form of carbonic acid, are substantially adsorbed by adsorbent material 170 comprising soda-lime granules in an exothermic reaction yielding purified air 132.

**[0050]** As used herein:

"CO<sub>2</sub> adsorbing canister" refers to a canister having a flow way therethrough and containing a CO<sub>2</sub> adsorbent material;

"CO<sub>2</sub> adsorbent material" refers to any material that substantially adsorbs CO<sub>2</sub>, including, but not limited to soda lime;

"substantially adsorbs CO<sub>2</sub>" refers to adsorption of a substantial percentage of CO<sub>2</sub>, such that, by way of example, if expired unpurified air volume 122 contains 3% CO<sub>2</sub>, purified air volume 132 contains about 1% CO<sub>2</sub>; and

"purified air" refers to air 132 from which CO<sub>2</sub> has been substantially adsorbed.

**[0051]** In embodiments, a compressed volume of O<sub>2</sub> 168 in O<sub>2</sub> bottle 110 is continually released during operation of emergency escape breathing device 100 through regulator 153 as noted above. Regulator 153 typically has a simple, lightweight and robust design and, as noted above, is embedded in O<sub>2</sub> bottle 110. Regulator 153 assumes an open position to begin the release of O<sub>2</sub> 168 and remains open throughout operation of emergency escape breathing device 100.

**[0052]** In addition to protecting regulator 153, recessing regulator into O<sub>2</sub> bottle 110 enables a short, direct coupling between regulator 153 and O<sub>2</sub> bottle 110 that is robust and substantially resistant to damage.

**[0053]** In embodiments, recessed regulator 153 serves as a lid that closes the opening to O<sub>2</sub> bottle 110. The many configurations for connecting regulator 153 to O<sub>2</sub> bottle 110 are well known to those familiar with the art.

**[0054]** In embodiments, bottle housing 157 and/or canister housing 120 protect O<sub>2</sub> bottle 110 from impact damage should a user drop emergency escape breathing device 100 during use.

**[0055]** In some heated environments, for example in a hot escape passage, an unprotected O<sub>2</sub> bottle 110 will heat up and cause a burn should the user touch the O<sub>2</sub> bottle 110. Bottle housing 157 and/or canister housing 120 protect O<sub>2</sub> bottle 110 so that the user is protected from burns in a hot environment.

**[0056]** In embodiments, demand valve 125 responds

to light pressure; such light pressure being supplied by counter lung 160, for example when counter lung 160 has collapsed due to rapid breathing by the user and rapid consumption of homogenous air 180 at a rate greater than release of O<sub>2</sub> at approximately 1.2 - 1.5 liters of O<sub>2</sub> per minute noted above.

**[0057]** The light pressure on demand valve 125 from counter lung 160 activates a rapid burst of O<sub>2</sub> 168 from O<sub>2</sub> bottle 110, at approximately 80 liters of O<sub>2</sub> per minute, noted above, to supply the user with homogenous air 180 enriched with O<sub>2</sub> in spite of having depleted the contents of counter lung 160. In this manner, demand valve 125 provides additional safety so that the user will continually have access to homogenous air 180 enriched with O<sub>2</sub>.

**[0058]** In embodiments, a substantial mixing 124 results in substantially homogenous air 180, purified of CO<sub>2</sub> and enriched with O<sub>2</sub>.

**[0059]** Purified air 180 then returns to mouthpiece 140 by passing back from counter lung 160, enriched with O<sub>2</sub> 164, ensuring that the user continually receives a proper amount of O<sub>2</sub> 164 in each inspiration. Enriched air 180 for inspiration passes back through mouthpiece via a return passage 112 that directs air 180 from counter lung 160 to mouthpiece 140.

**[0060]** In embodiments, as compressed O<sub>2</sub> 168 in O<sub>2</sub> bottle 110 expands, O<sub>2</sub> bottle 110 cools. As enriched O<sub>2</sub> 180 flows in passage 112 along cooled O<sub>2</sub> bottle 110, enriched air 180 loses heat associated with the user body temperature and the above-noted exothermic chemical reaction in adsorption canister 121, and becomes cooled air 186. This arrangement, whereby hot air 180 becomes cooled air 186 through contact with O<sub>2</sub> bottle 110, ensures that the user receives a supply of returning air 186 at a comfortable temperature, helping to prevent user panic and shock noted above.

**[0061]** In embodiments, mouthpiece 140 includes a back pass capillary valve 192 and a forward pass capillary valve 194. As expired air 122 is expired forward from mouthpiece 140 into canister 121, back pass capillary valve 192 closes to prevent back passing air 186 from passing through mouthpiece 140. Conversely, as cooled air 186 is inspired through mouthpiece 140, forward pass capillary valve 194 closes to prevent forward passing expired air 122 from passing through mouthpiece 140.

**[0062]** Further, the serial closures of back pass capillary valve 192 and forward pass capillary valve 194 ensure that forward passing expired air 122 forms a circular airflow emergency escape breathing device 100 that promotes substantial enrichment of enriched air 180.

**[0063]** Additionally, the closure of back pass capillary valve 192 additionally ensures that CO<sub>2</sub> adsorbent material 170 contained in CO<sub>2</sub> adsorbing canister 121 does not accidentally make it's way into the user inhalation and harm the user.

**[0064]** Moreover, the light weight of emergency escape breathing device 100 allows a user to rapidly escape a hostile environment; the large capacity of counter lung 160 allows extended breathing while regulator 153 is pro-

tected from damage.

**[0065]** It is expected that during the life of this patent many relevant emergency escape breathing devices will be developed and the scope of the term emergency escape breathing device is intended to include all such new technologies *a priori*.

**[0066]** As used herein the term "about" refers to  $\pm 10\%$ .

**[0067]** Additional objects, advantages, and novel features of the present invention will become apparent to one ordinarily skilled in the art upon examination of the following examples, which are not intended to be limiting. Additionally, each of the various embodiments and aspects of the present invention as delineated hereinabove and as claimed in the claims section below finds experimental support in the following examples.

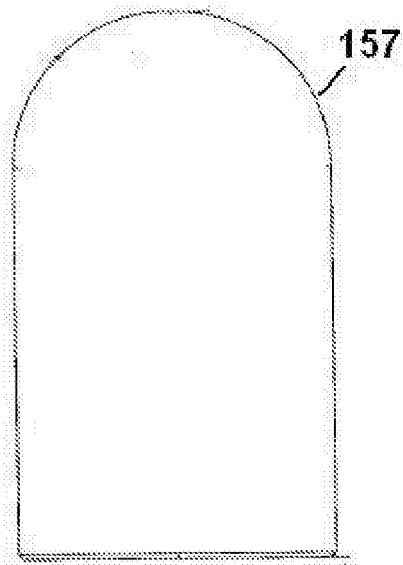
**[0068]** It is appreciated that certain features of the invention, which are, for clarity, described in the context of separate embodiments, may also be provided in combination in a single embodiment. Conversely, various features of the invention, which are, for brevity, described in the context of a single embodiment, may also be provided separately or in any suitable subcombination.

**[0069]** Although the invention has been described in conjunction with specific embodiments thereof, it is evident that many alternatives, modifications and variations will be apparent to those skilled in the art. Accordingly, it is intended to embrace all such alternatives, modifications and variations that fall within the spirit and broad scope of the appended claims. All publications, patents and patent applications mentioned in this specification are herein incorporated in their entirety by reference into the specification, to the same extent as if each individual publication, patent or patent application was specifically and individually indicated to be incorporated herein by reference. In addition, citation or identification of any reference in this application shall not be construed as an admission that such reference is available as prior art to the present invention.

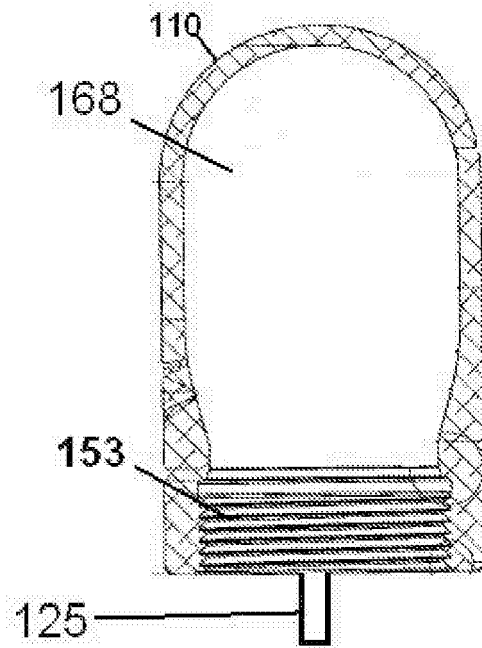
## Claims

1. An emergency escape breathing device, comprising:
  - an oxygen bottle configured to contain compressed oxygen;
  - an oxygen release regulator that releases said compressed oxygen at a constant rate during use of said emergency escape breathing device, said oxygen release regulator being substantially contained within said oxygen bottle.
2. The device according to claim 1, wherein said oxygen bottle comprises a substantially monotonous configuration.
3. The device according to claim 1, wherein said oxy-

- gen bottle is contained within a protective housing.
4. The device according to claim 3, wherein said protective housing is configured to protect said oxygen bottle against at least one of:
- impact; and  
heat buildup.
5. The device according to claim 1, wherein said oxygen bottle is configured to contain dry oxygen.
6. The device according to claim 5, wherein said oxygen release regulator is configured to release said dry oxygen at said constant rate.
7. The device according to claim 1, including a counter lung comprising a chamber, said chamber in an unexpanded configuration being enclosed by at least two substantially parallel walls and a perimeter connecting said at least two substantially parallel walls, said perimeter including at least one fold that substantially extends into said chamber.
8. The device according to claim 7, wherein when said chamber is in an expanded configuration, said at least one fold substantially unfolds and at least a portion of said two walls diverge.
9. The device according to claim 7, including forward and backpass valves operatively associated with said counter lung.
10. The device according to claim 9, wherein said forward and backpass valves promote a circular airflow within said device.
11. An emergency escape breathing device, comprising: a counter lung comprising a chamber, said chamber in an unexpanded configuration being enclosed by at least two substantially parallel walls and a perimeter connecting said at least two substantially parallel walls, said perimeter including at least one fold that substantially extends into said chamber.
12. The device according to claim 11, wherein when said chamber is in an expanded configuration, said at least one fold substantially unfolds and at least a portion of said two walls diverge.
13. An emergency escape breathing device, comprising:
- an oxygen bottle configured to contain compressed oxygen;  
an oxygen release regulator configured to release said compressed oxygen at a constant rate during use of said emergency escape breathing device, said oxygen release regulator
- being substantially contained within said oxygen bottle; and  
a counter lung comprising a chamber, said chamber in an unexpanded configuration being enclosed by at least two substantially parallel walls and a perimeter connecting said at least two substantially parallel walls, said perimeter including at least one fold that substantially extends into said chamber.
14. The device according to claim 13, wherein when said chamber is in an expanded configuration, said at least one fold substantially unfolds and at least a portion of said two walls diverge.
15. The device according to claim 13, wherein said oxygen bottle comprises a substantially monotonous configuration.
16. The device according to claim 13, wherein said oxygen bottle is contained within a protective housing.
17. The device according to claim 16, wherein said protective housing is configured to protect said oxygen bottle from at least one of:
- impact; and  
heat buildup.

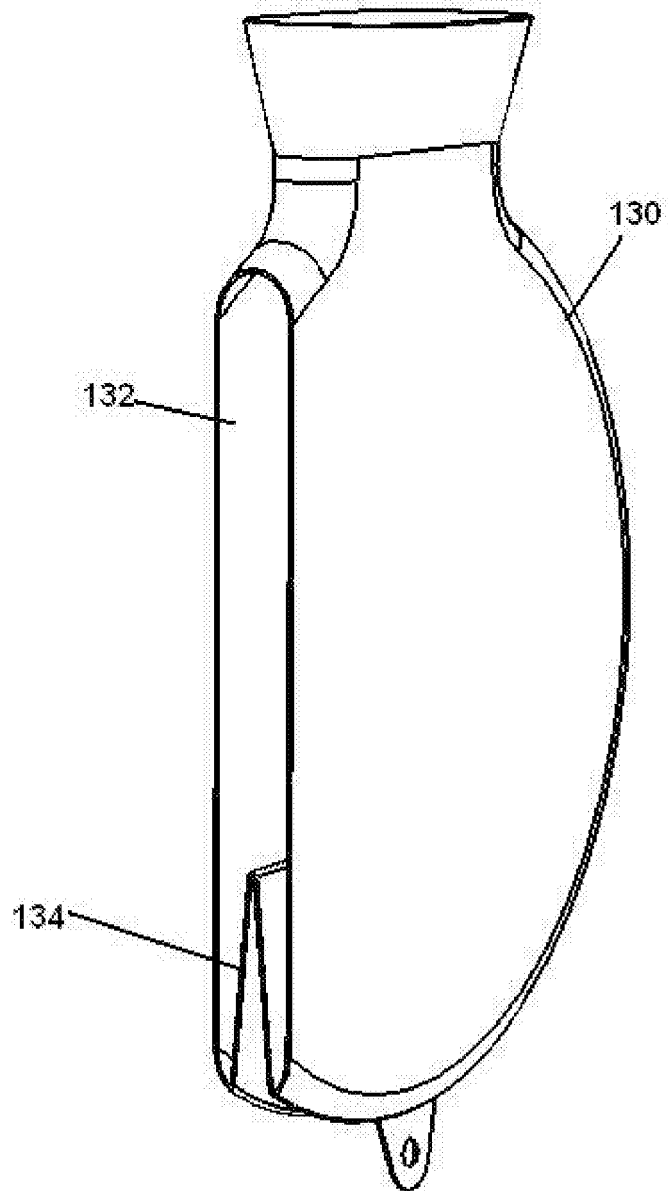


**Fig. 1**

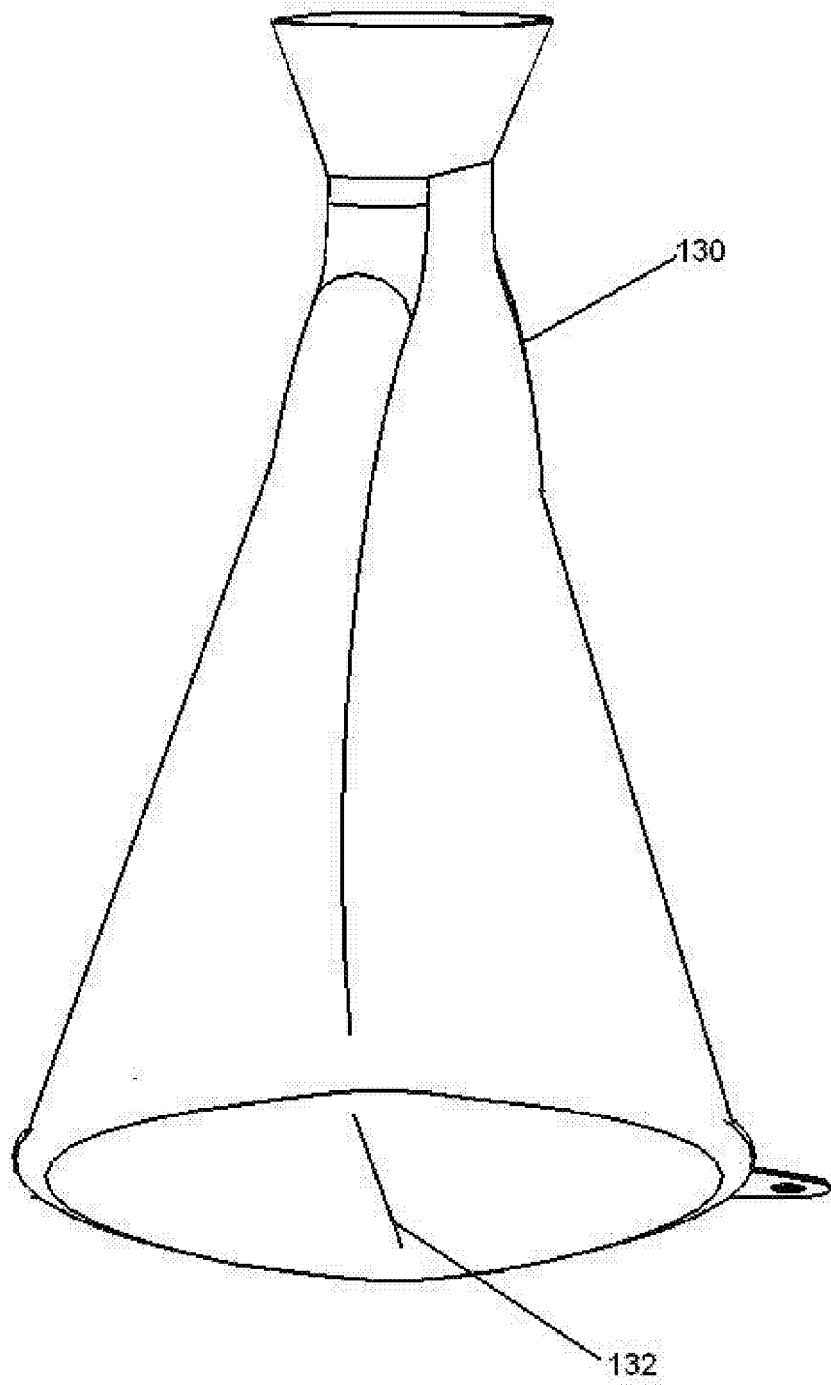


**Fig. 2**

**Fig. 3**



**Fig. 4**



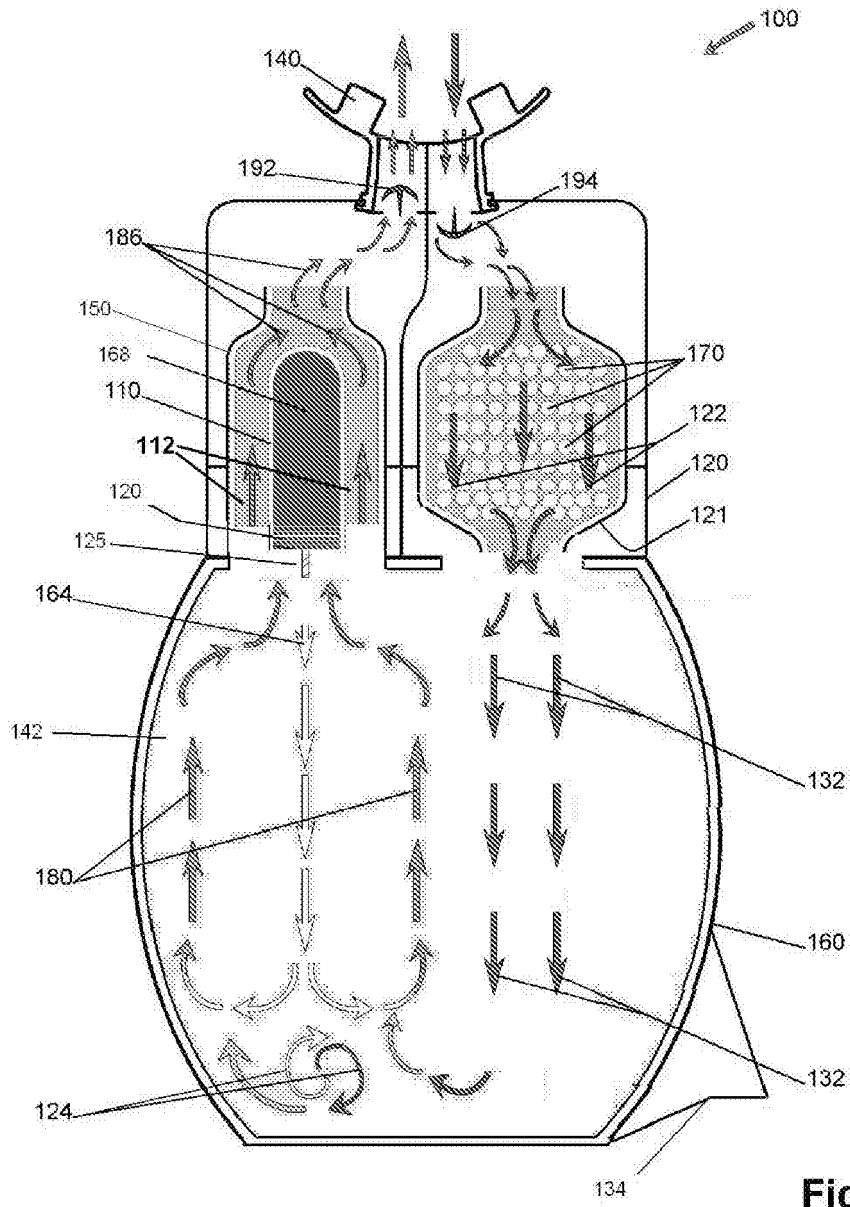


Fig. 5



DOCUMENTS CONSIDERED TO BE RELEVANT			
Category	Citation of document with indication, where appropriate, of relevant passages	Relevant to claim	CLASSIFICATION OF THE APPLICATION (IPC)
X	US 4 802 472 A (JUNG SAKUN) 7 February 1989 (1989-02-07) * figures 1,2,4 * * column 1, lines 6,7 * * column 2, lines 59-67 * * column 4, lines 17-20 * -----	1-6	INV. A62B/04
X	EP 1 106 500 A (CUMMING) 13 June 2001 (2001-06-13) * figure 1 * * column 1, lines 3,4 * * column 5, lines 51-54 * * column 6, lines 5-7 * * column 7, lines 11-14 * -----	11,12	
A	EP 0 079 709 A (OCENCO) 25 May 1983 (1983-05-25) * the whole document * -----	13	
The present search report has been drawn up for all claims			TECHNICAL FIELDS SEARCHED (IPC)
			A62B B63C
Place of search		Date of completion of the search	Examiner
The Hague		19 December 2007	Paul, Adeline
CATEGORY OF CITED DOCUMENTS			
X : particularly relevant if taken alone		T : theory or principle underlying the invention	
Y : particularly relevant if combined with another document of the same category		E : earlier patent document, but published on, or after the filing date	
A : technological background		D : document cited in the application	
O : non-written disclosure		L : document cited for other reasons	
P : intermediate document		& : member of the same patent family, corresponding document	

2  
EPO FORM 1503 03.02 (P04C01)

**ANNEX TO THE EUROPEAN SEARCH REPORT  
ON EUROPEAN PATENT APPLICATION NO.**

EP 07 11 2051

This annex lists the patent family members relating to the patent documents cited in the above-mentioned European search report. The members are as contained in the European Patent Office EDP file on The European Patent Office is in no way liable for these particulars which are merely given for the purpose of information.

19-12-2007

Patent document cited in search report		Publication date	Patent family member(s)	Publication date
US 4802472	A	07-02-1989	NONE	
-----				
EP 1106500	A	13-06-2001	GB 2357979 A	11-07-2001
			US 2001015203 A1	23-08-2001
-----				
EP 0079709	A	25-05-1983	NONE	
-----				

EPO FORM P0459

For more details about this annex : see Official Journal of the European Patent Office, No. 12/82

**REFERENCES CITED IN THE DESCRIPTION**

*This list of references cited by the applicant is for the reader's convenience only. It does not form part of the European patent document. Even though great care has been taken in compiling the references, errors or omissions cannot be excluded and the EPO disclaims all liability in this regard.*

**Patent documents cited in the description**

- US 7140591 B [0004]
- US 6997348 B, Droppelman [0004]
- US 4440163 A, Spergel [0006]