

(19) World Intellectual Property Organization
International Bureau



(43) International Publication Date
17 August 2006 (17.08.2006)

PCT

(10) International Publication Number
WO 2006/085202 A1

(51) International Patent Classification:

B60N 2/70 (2006.01) **B29C 44/32** (2006.01)
A47C 7/14 (2006.01) **B29C 70/68** (2006.01)
B62J 1/26 (2006.01) **B29C 70/72** (2006.01)

(21) International Application Number:

PCT/IB2006/000258

(22) International Filing Date:

10 February 2006 (10.02.2006)

(25) Filing Language:

Italian

(26) Publication Language:

English

(30) Priority Data:

VI2005A000040 10 February 2005 (10.02.2005) IT

(71) Applicant (for all designated States except US): **SELLE ROYAL S.P.A.** [IT/IT]; Via Vittorio Emanuele, 141, I-36050 Pozzoleone (IT).

(72) Inventor; and

(75) Inventor/Applicant (for US only): **SEGATO, Stefano** [IT/IT]; Corso Padova, 140/a, I-36100 Vicenza (IT).

(74) Agent: **MAROSCIA, Antonio**; Maroscia & Associati S.r.l., Contra's Caterina, 29, I-36100 Vicenza (IT).

(81) Designated States (unless otherwise indicated, for every kind of national protection available): AE, AG, AL, AM, AT, AU, AZ, BA, BB, BG, BR, BW, BY, BZ, CA, CH, CN, CO, CR, CU, CZ, DE, DK, DM, DZ, EC, EE, EG, ES, FI, GB, GD, GE, GH, GM, HR, HU, ID, IL, IN, IS, JP, KE, KG, KM, KN, KP, KR, KZ, LC, LK, LR, LS, LT, LU, LV, LY, MA, MD, MG, MK, MN, MW, MX, MZ, NA, NG, NI, NO, NZ, OM, PG, PH, PL, PT, RO, RU, SC, SD, SE, SG, SK, SL, SM, SY, TJ, TM, TN, TR, TT, TZ, UA, UG, US, UZ, VC, VN, YU, ZA, ZM, ZW.

(84) Designated States (unless otherwise indicated, for every kind of regional protection available): ARIPO (BW, GH, GM, KE, LS, MW, MZ, NA, SD, SL, SZ, TZ, UG, ZM, ZW), Eurasian (AM, AZ, BY, KG, KZ, MD, RU, TJ, TM), European (AT, BE, BG, CH, CY, CZ, DE, DK, EE, ES, FI, FR, GB, GR, HU, IE, IS, IT, LT, LU, LV, MC, NL, PL, PT, RO, SE, SI, SK, TR), OAPI (BF, BJ, CF, CG, CI, CM, GA, GN, GQ, GW, ML, MR, NE, SN, TD, TG).

Published:

- with international search report
- before the expiration of the time limit for amending the claims and to be republished in the event of receipt of amendments

For two-letter codes and other abbreviations, refer to the "Guidance Notes on Codes and Abbreviations" appearing at the beginning of each regular issue of the PCT Gazette.

(54) Title: ERGONOMIC SUPPORT STRUCTURE FOR HUMAN BODY PARTS AND METHOD OF MANUFACTURING SAME

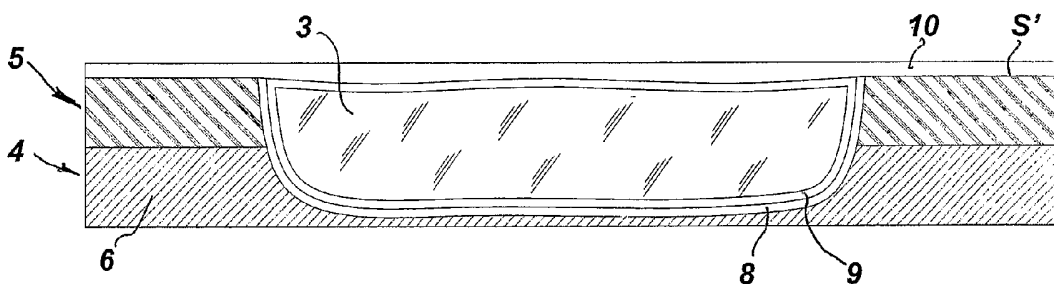

(57) Abstract: An ergonomic support structure, particularly for supporting parts of the human body. The structure (1) comprises a main body (2) with a viscoelastic insert (2) permanently anchored thereto. The main body (2) has at least one first layer (4) made of a material selected from those having a relatively low density and a relatively high mechanical strength, which is associated to at least one second layer of polymer resin for monolithically anchoring said at least one insert (3). A process for making the above structure.



WO 2006/085202 A1

ERGONOMIC SUPPORT STRUCTURE, FOR HUMAN BODY PARTS AND
METHOD OF MANUFACTURING SAME

Field of the invention

5

This invention finds application in the field of mechanical structures made of special materials, and particularly relates to an ergonomic support structure.

Furthermore, the invention relates to a process for making the above structure.

10

Background of the invention

Cover pads of foam material are known to be used to enhance comfort and ergonomic benefit of support structures, such as bicycle saddles, car seats or the
15 like.

Nevertheless, this solution is unacceptably uncomfortable, inconvenient, and aesthetically prejudicial for the structure.

20 In an attempt to obviate the above drawbacks, gel inserts are being increasingly used at the areas subjected to the highest pressure by users, to provide comfort where this is most needed. Gel is preferable as compared with foam, due to its higher viscoelasticity and better ergonomic properties.

25 WO2004-089682 discloses an ergonomic cushion for motor vehicle seats, having gel inserts at the ischial regions.

One drawback of this prior art structure is that, although it is undoubtedly comfortable and resilient, the fabric sheath that encapsulates the gel tends to be easily cut and
30 ruptured, with gel tending to leak therefrom. Furthermore, the gel insert, which would be pleasant to the sight, is covered thereby.

An additional general problem is that the cushion is separate from the seat, and therefore it is uncomfortable and makes the structure bulkier.

Other technically equivalent arrangements are known from US-2004-098806, US-A-
5 4197342, US-A-6009578.

US-B-6454352 discloses a car seat with encapsulated gel pads, capable of deformation when in contact with moving parts of a user.

10 While this solution is convenient and not exposed to undesired damaging, it has the drawback of incorporating a pad, which makes the structure bulkier and unpleasant to the view.

Summary of the Invention

15 The object of this invention is to overcome the above drawbacks, by providing a support structure that is highly efficient and relatively cost-effective.

A particular object is to provide a support structure having a light weight and a high
20 strength.

A further object is to provide a support structure that can be customized, i.e. adapted to the anthropometric structure of any user whatever.

25 Another object of the invention is to provide a support structure that is pleasant to the sight.

Yet another object of the invention is to provide a highly practical and cost-effective process for making the structure of the invention.

30 These objects, as well as other objects that will be more apparent hereafter, are fulfilled by an ergonomic support structure, according to claim 1, which comprises a

main body with a viscoelastic insert permanently anchored thereto, wherein the main body has at least one first layer made of a material selected from those having a relatively low density and a relatively high mechanical strength, said first layer being associated to at least one second layer of polymer resin, for monolithically anchoring
5 said at least one insert.

Thanks to this particular configuration, the structure of the invention has a very light weight and enhanced sturdiness, and allows to avoid the use of pads, that were used as comfort elements in prior art structures. This allows to make structures that are
10 both comfortable and of a very light weight.

Furthermore, the structure of the invention is highly comfortable, particularly suitable for the fabrication of bicycle saddles, car seats, chairs, wrist supports or the like.

15 Advantageously, this at least one insert may be placed over said at least one first layer to define a free contact surface for the user suitable of controlled deformation.

Thanks to this feature, the structure of the invention meets the needs of various users, regardless of specific anthropometric structures of the parts of human bodies
20 in contact with the structure. The natural ergonomic properties of the viscoelastic material allow the structure to be easily and comfortable adapted to anyone.

Also, the lack of a pad provides an assembly that is highly pleasing to the sight, a non-negligible advantage in the field of sports and leisure, which is highly influenced
25 by fashion and aesthetics.

Suitably, the structure of the invention may have a thermoplastic cover layer, placed over said at least one insert and the top surface of said at least one first layer.

30 Thanks to this feature, the structure is highly pleasant to the touch and safe, as it protects users from any rupture of the first layer which might otherwise have dangerous structural discontinuities and injure the users.

According to another aspect of the invention there is provided a process for making an ultralight ergonomic support structure like the one disclosed above, according to claim 10, which includes the steps of: providing a mold having an inner cavity of a predetermined shape which corresponds to the external configuration of a main body
5 of a support structure; opening said mold and laying thereon at least one first layer made of a material selected from those having a relatively low density and a relatively high mechanical strength; placing at least one third layer of a polymer material having relatively high adhesive properties on said at least one first layer; placing at least one viscoelastic insert in said mold; placing at least one second layer
10 of a polymer resin; sealing said mold and heating it to a predetermined operating temperature; cooling said mold to a predetermined final temperature and opening said mold and removing the finished support structure.

Brief description of the drawings

15

Further features and advantages of the invention will be more apparent from the detailed description of a preferred, non-exclusive embodiment of a structure according to the invention, which is described by way of non-limiting example with reference to the annexed drawings, in which:

20 FIG. 1 is an axonometric view of a support structure according to the invention;

FIG. 2 is an axonometric view of a detail of FIG. 1;

FIG. 3 is a sectioned view of the structure of the invention, as taken along a plane *III-III*;

25 FIG. 4 is another sectioned view of the structure of the invention, as taken along a plane *IV-IV*;

Fig. 5 shows a flowchart of a process for making the support structure of the invention.

Detailed description of a preferred embodiment

30

Referring to the above figures, the structure of the invention, generally designated by numeral 1, may be, for instance, a part of a chair, a bicycle saddle, a wrist support or

a car seat, as shown in FIG. 1.

Typically, the structure 1 comprises a main body 2, with the viscoelastic insert 3, preferably made of polyurethane gel, permanently anchored thereto. This defines a
5 free contact surface S for the user and, thanks to its natural ergonomic properties, it may be freely placed at the contact areas between the user and the structure 1. The main body 2 may include, for instance, a first layer 4 associated to a second layer 5.

Particularly, the member 4 has a low density and a high mechanical strength, i.e. a
10 high resistance to compressive and/or tensile and/or bending and/or torsional and/or shearing stresses. Furthermore, as is known, the second layer 5 is essentially composed of one or more thermoplastic or thermosetting resins, possibly reinforced.

According to the invention, the first layer 4 may include a metal sheet 6, e.g. made of
15 titanium, aluminum, stainless steel, magnesium or the like, associated to the layer 5, and wholly or partly covered thereby, as shown in FIG. 3.

In accordance with this configuration of the invention, the inserts 3 may be anchored
20 by an adhesive polymer film 8, which is used to bind the insert 3 and the sheet 6, as shown in FIG. 4.

In this case, to allow handling of the insert 3, the latter may be covered by a
25 protective layer 9 of a material adapted to oppose its high inherent adhesiveness, such as a polyurethane paint.

Advantageously, the structure 1 may have a thermoplastic cover layer 10, having
protection functions.

Suitably, the layer 10 may be transparent, so that the aesthetically pleasing
30 connection between the material of the body 2 and the gel of the insert 3 is visible. A process for making the structure 1 includes the following steps.

In the first step a) a mold is provided, having an inner cavity of a predetermined shape, which corresponds to the external configuration of the main body 2 of the support structure.

5 Then, in step b), the mold is opened and the first layer 4 is laid thereon, and in step d) one or more inserts 3 are placed thereon after a step c) in which the adhesive 8 is applied on the member 4.

10 In step e) the second layer of polymer resin 5 is laid, to provide a monolithic structure. Conveniently, the cover layer 10 may be placed in the mold to protect the assembly, thereby providing the above mentioned advantages.

15 Then, in step f), the mold is hermetically sealed and heated to a predetermined operating temperature, which may be in a range of 20°C to 300°C, and will preferably be of about 120°C. Such temperature will be typically close to the glass transition temperature of the resin layer 5. In this step, chemical and/or mechanical bonds will be formed to form a monolithic assembly from the body 2 and the inserts 3.

20 After a step g), in which the mold is cooled to a predetermined final temperature, in a range of 18°C to 50°C, and preferably of about 20°C, the final step h) will follow, during which the mold is opened, and the finished support structure 1 is removed therefrom.

25 The above disclosure clearly shows that the structure of the invention fulfills the proposed objects and particularly meets the requirement of providing a highly comfortable and light support structure.

30 By using low density and high strength materials, in combination with the gel of the insert 3, a very comfortable structure is obtained, which is capable of fitting the anthropometric structure of any user whatever, while reducing the overall weight and maintaining sturdiness.

The structure of the invention is susceptible of a number of changes and variants, within the inventive concept disclosed in the appended claims. All the details thereof may be replaced by other technically equivalent parts, and the materials may vary depending on different needs, without departure from the scope of the invention.

5

While the structure has been described with particular reference to the accompanying figures, the numerals referred to in the disclosure and claims are only used for the sake of a better intelligibility of the invention and shall not be intended to limit the claimed scope in any manner.

CLAIMS

1. An ergonomic support structure, particularly for supporting parts of the human body, comprising a main body (2) with a viscoelastic insert (3) permanently anchored thereto, wherein said main body (2) has at least one first layer (4) made of a material selected from those having a relatively low density and a relatively high mechanical strength, said at least one first layer (4) being associated to at least one second layer (5) of polymer resin for monolithically anchoring said at least one insert (3).
2. A structure as claimed in claim 1, characterized in that said at least one insert (3) is placed over said at least one first layer (4) to define a free contact surface (S) for the user suitable of controlled deformation.
3. A structure as claimed in claim 1, characterized in that said at least one first layer (4) includes a metal sheet (6) which is designed to be associated to said at least one second layer (5) of polymer resin.
4. A structure as claimed in claim 3, characterized in that said metal material is selected from titanium, aluminum, stainless steel, magnesium or the like.
5. A structure as claimed in claim 3, characterized in that said at least one viscoelastic insert (3) is anchored to said metal sheet (6) by at least one third layer (8) of a polymer material having relatively high adhesive properties.
6. A structure as claimed in claim 1, characterized in that it comprises a thermoplastic cover layer (10), placed over said at least one insert (3) and the top surface (S') of said at least one first layer (4).
7. A structure as claimed in claim 6, characterized in that said cover layer (10) is of the transparent type.

8. A structure as claimed in claim 1, characterized in that said viscoelastic material is a gel material.
9. A structure as claimed in claim 8, characterized in that said gel is selected
5 from the group of polyurethane gels.
10. A process for making an ultralight ergonomic support structure of composite material, particularly for supporting parts of the human body, as claimed in one or more of claims 1 to 9, comprising the steps of:
- 10 a) providing a mold having an inner cavity of a predetermined shape which corresponds to the external configuration of a main body (2) of a support structure;
- b) opening said mold and laying thereon at least one first layer (4) made of a material selected from those having a relatively low density and a relatively high resistance to compressive and/or shearing stresses;
- 15 c) placing at least one layer (8) of a polymer material having relatively high adhesive properties on said at least one first layer (4);
- d) placing at least one viscoelastic insert (3) in said mold;
- e) placing at least one second layer (5) of a polymer resin;
- f) hermetically sealing said mold and heating it to a predetermined operating
20 temperature;
- g) cooling said mold to a predetermined final temperature;
- h) opening said mold and removing the finished support structure therefrom;
11. A process as claimed in claim 10, characterized in that it comprises a step
25 during which a thermoplastic cover layer (10) is placed over said at least one insert (3) and the top surface (S') of said at least one first layer (4).
12. A process as claimed in claim 10, characterized in that said predetermined operating temperature is of 20°C to 300°C and is preferably of about 120°C.
- 30 13. A process as claimed in claim 10, characterized in that said predetermined final temperature is of 18°C to 50°C and is preferably of about 20°C.

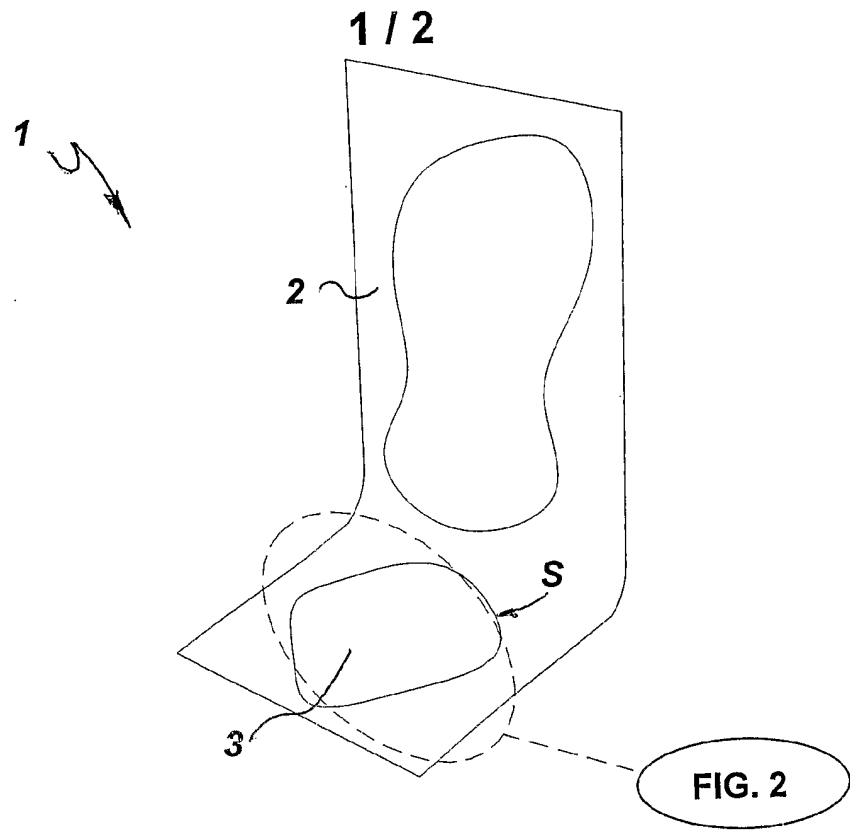

FIG. 1

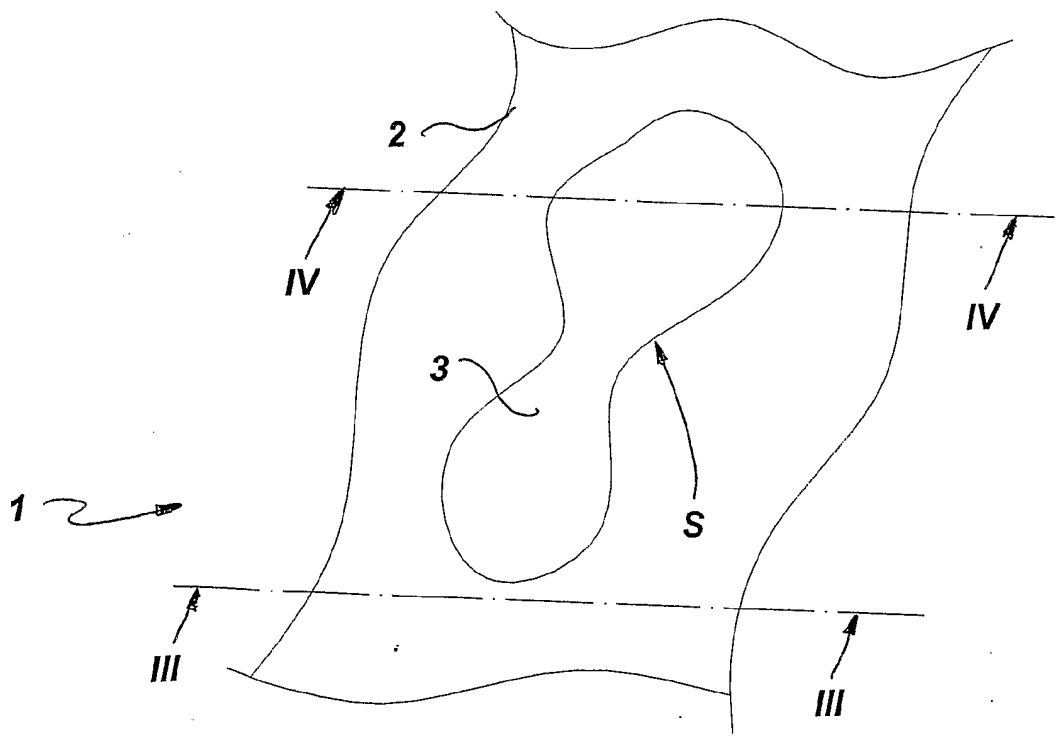

FIG. 2

2 / 2

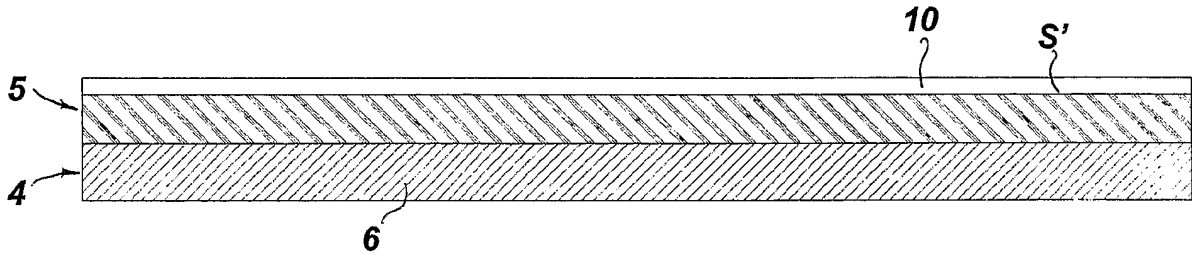

FIG. 3

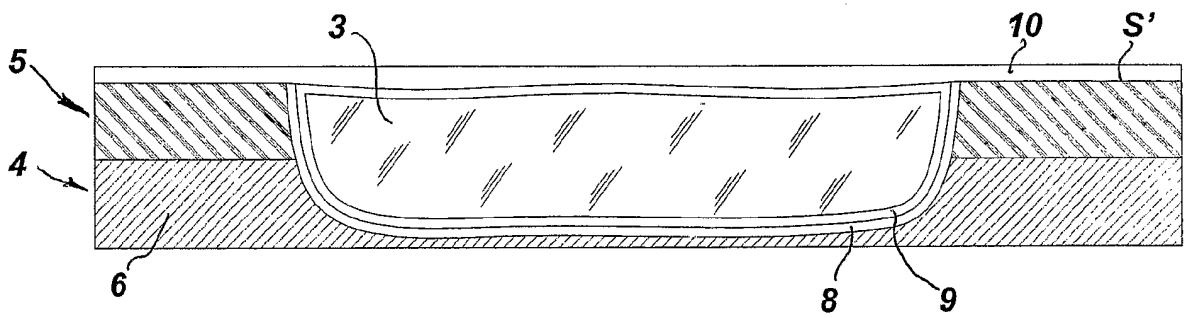

FIG. 4

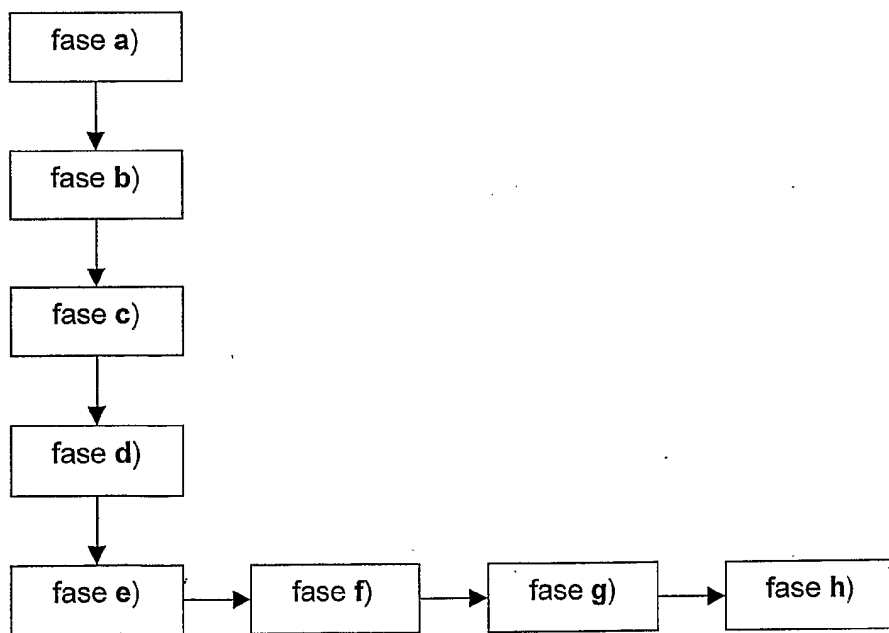

FIG. 5

INTERNATIONAL SEARCH REPORT

International application No
PCT/IB2006/000258

A. CLASSIFICATION OF SUBJECT MATTER
INV. B60N2/70 A47C7/14
B29C70/72

B62J1/26

B29C44/32

B29C70/68

According to International Patent Classification (IPC) or to both national classification and IPC

B. FIELDS SEARCHED

Minimum documentation searched (classification system followed by classification symbols)
B60N A47C B62J B29C A61F

Documentation searched other than minimum documentation to the extent that such documents are included in the fields searched

Electronic data base consulted during the international search (name of data base and, where practical, search terms used)

EPO-Internal, WPI Data, PAJ

C. DOCUMENTS CONSIDERED TO BE RELEVANT

Category*	Citation of document, with indication, where appropriate, of the relevant passages	Relevant to claim No.
X	EP 0 903 321 A (SELLE ROYAL S.P.A) 24 March 1999 (1999-03-24) the whole document	1,2,5-10
X	US 2003/025363 A1 (GAGGIOLA) 6 February 2003 (2003-02-06) the whole document	1-5,8,9
X	PATENT ABSTRACTS OF JAPAN vol. 1996, no. 12, 26 December 1996 (1996-12-26) & JP 08 197651 A (YAMAHA MOTOR CO LTD), 6 August 1996 (1996-08-06) abstract	1-3
	----- -/--	

Further documents are listed in the continuation of Box C.

See patent family annex.

* Special categories of cited documents :

- *A* document defining the general state of the art which is not considered to be of particular relevance
- *E* earlier document but published on or after the international filing date
- *L* document which may throw doubts on priority claim(s) or which is cited to establish the publication date of another citation or other special reason (as specified)
- *O* document referring to an oral disclosure, use, exhibition or other means
- *P* document published prior to the international filing date but later than the priority date claimed

- *T* later document published after the international filing date or priority date and not in conflict with the application but cited to understand the principle or theory underlying the invention
- *X* document of particular relevance; the claimed invention cannot be considered novel or cannot be considered to involve an inventive step when the document is taken alone
- *Y* document of particular relevance; the claimed invention cannot be considered to involve an inventive step when the document is combined with one or more other such documents, such combination being obvious to a person skilled in the art.
- *&* document member of the same patent family

Date of the actual completion of the international search

5 July 2006

Date of mailing of the international search report

13/07/2006

Name and mailing address of the ISA/
European Patent Office, P.B. 5818 Patentlaan 2
NL - 2280 HV Rijswijk
Tel. (+31-70) 340-2040, Tx. 31 651 epo nl,
Fax: (+31-70) 340-3016

Authorized officer

Kis, P

INTERNATIONAL SEARCH REPORT

International application No
PCT/IB2006/000258

C(Continuation). DOCUMENTS CONSIDERED TO BE RELEVANT

Category*	Citation of document, with indication, where appropriate, of the relevant passages	Relevant to claim No.
A	US 5 976 098 A (SEREBOFF ET AL) 2 November 1999 (1999-11-02) paragraph [0004] - paragraph [0007]; figures 2-4 -----	1-5
A	WO 2004/089682 A (RENAULT S.A.S) 21 October 2004 (2004-10-21) cited in the application abstract -----	1,2,8
A	US 2004/098806 A1 (STENDER ET AL) 27 May 2004 (2004-05-27) cited in the application claims 1-24; figures 1-3 -----	1,2,5,8, 9

INTERNATIONAL SEARCH REPORT

Information on patent family members

International application No

PCT/IB2006/000258

Patent document cited in search report		Publication date	Patent family member(s)	Publication date
EP 0903321	A	24-03-1999	AT 222564 T	15-09-2002
			BR 9803456 A	16-11-1999
			DE 69807299 D1	26-09-2002
			DE 69807299 T2	17-04-2003
			HK 1019438 A1	02-05-2003
			IT VI970160 A1	18-12-1997
			JP 11151388 A	08-06-1999
			US 6136426 A	24-10-2000

US 2003025363	A1	06-02-2003	NONE	

JP 08197651	A	06-08-1996	JP 3505586 B2	08-03-2004

US 5976098	A	02-11-1999	NONE	

WO 2004089682	A	21-10-2004	EP 1608531 A2	28-12-2005
			FR 2853287 A1	08-10-2004

US 2004098806	A1	27-05-2004	AT 317655 T	15-03-2006
			DE 10254678 A1	09-06-2004
			EP 1421878 A1	26-05-2004
