

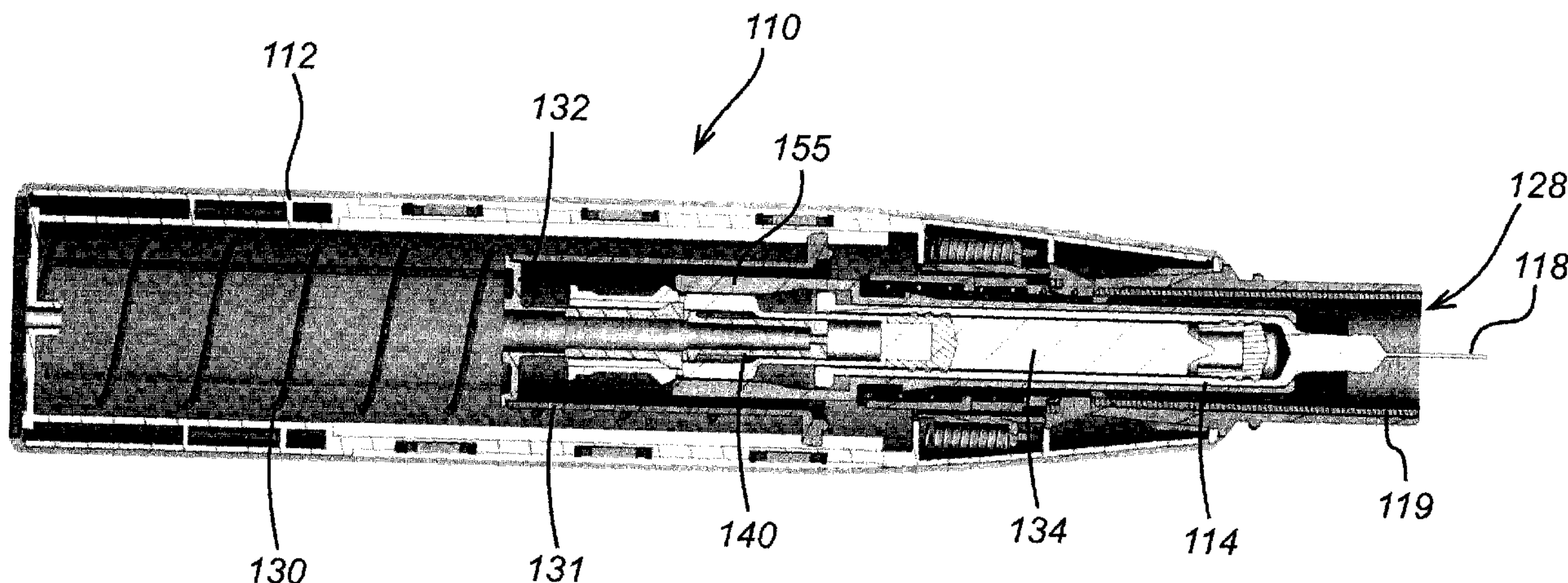

(86) Date de dépôt PCT/PCT Filing Date: 2005/05/27
 (87) Date publication PCT/PCT Publication Date: 2005/12/08
 (45) Date de délivrance/Issue Date: 2013/07/30
 (85) Entrée phase nationale/National Entry: 2006/11/24
 (86) N° demande PCT/PCT Application No.: GB 2005/002108
 (87) N° publication PCT/PCT Publication No.: 2005/115507
 (30) Priorité/Priority: 2004/05/28 (GB0412053.1)

(51) Cl.Int./Int.Cl. *A61M 5/20* (2006.01),
A61M 5/32 (2006.01)
 (72) Inventeur/Inventor:
HARRISON, NIGEL, GB
 (73) Propriétaire/Owner:
CILAG GMBH INTERNATIONAL, CH
 (74) Agent: NORTON ROSE FULBRIGHT CANADA
LLP/S.E.N.C.R.L., S.R.L.

(54) Titre : DISPOSITIF D'INJECTION
 (54) Title: INJECTION DEVICE



(57) Abrégé/Abstract:

An injection device (110) is described having a housing (112) that receives a syringe (114) having a needle (118), wherein the syringe is supported in a syringe carrier (150). The syringe and syringe carrier are biased by a return spring (126) from an extended position in which the needle (118) extends from the housing (112) through an exit aperture (128) to a retracted position in which it does not. A drive spring (130) acts via a drive to advance the syringe from its retracted position to its extended position and discharge its contents through the needle and a return spring, brought into play when the drive has reached a nominal return position, restores the syringe to its retracted position.



(12) INTERNATIONAL APPLICATION PUBLISHED UNDER THE PATENT COOPERATION TREATY (PCT)

(19) World Intellectual Property
Organization
International Bureau



(43) International Publication Date
8 December 2005 (08.12.2005)

PCT

(10) International Publication Number
WO 2005/115507 A1

- (51) International Patent Classification⁷: **A61M 5/20, 5/32**
- (21) International Application Number:
PCT/GB2005/002108
- (22) International Filing Date: 27 May 2005 (27.05.2005)
- (25) Filing Language: English
- (26) Publication Language: English
- (30) Priority Data:
0412053.1 28 May 2004 (28.05.2004) GB
- (71) Applicant (for all designated States except US): **CILAG AG INTERNATIONAL** [CH/CH]; Landis & Gyrstrasse 1, CH-6300 Zug (CH).
- (72) Inventor; and
- (75) Inventor/Applicant (for US only): **HARRISON, Nigel** [GB/GB]; PA Consulting Group, Cambridge Technology Centre, Melbourn, Hertfordshire SG8 6DP (GB).
- (74) Agents: **TUNSTALL, Christopher, Stephen** et al.; Carpmaels & Ransford, 43-45 Bloomsbury Square, London WC1A 2RA (GB).
- (81) Designated States (unless otherwise indicated, for every kind of national protection available): AE, AG, AL, AM, AT, AU, AZ, BA, BB, BG, BR, BW, BY, BZ, CA, CH, CN, CO, CR, CU, CZ, DE, DK, DM, DZ, EC, EE, EG, ES, FI, GB, GD, GE, GH, GM, HR, HU, ID, IL, IN, IS, JP, KE, KG, KM, KP, KR, KZ, LC, LK, LR, LS, LT, LU, LV, MA, MD, MG, MK, MN, MW, MX, MZ, NA, NG, NI, NO, NZ, OM, PG, PH, PL, PT, RO, RU, SC, SD, SE, SG, SK, SL, SM, SY, TJ, TM, TN, TR, TT, TZ, UA, UG, US, UZ, VC, VN, YU, ZA, ZM, ZW.
- (84) Designated States (unless otherwise indicated, for every kind of regional protection available): ARIPO (BW, GH, GM, KE, LS, MW, MZ, NA, SD, SL, SZ, TZ, UG, ZM, ZW), Eurasian (AM, AZ, BY, KG, KZ, MD, RU, TJ, TM), European (AT, BE, BG, CH, CY, CZ, DE, DK, EE, ES, FI, FR, GB, GR, HU, IE, IS, IT, LT, LU, MC, NL, PL, PT, RO, SE, SI, SK, TR), OAPI (BF, BJ, CF, CG, CI, CM, GA, GN, GQ, GW, ML, MR, NE, SN, TD, TG).
- Published:**
— with international search report
- For two-letter codes and other abbreviations, refer to the "Guidance Notes on Codes and Abbreviations" appearing at the beginning of each regular issue of the PCT Gazette.

(54) Title: INJECTION DEVICE

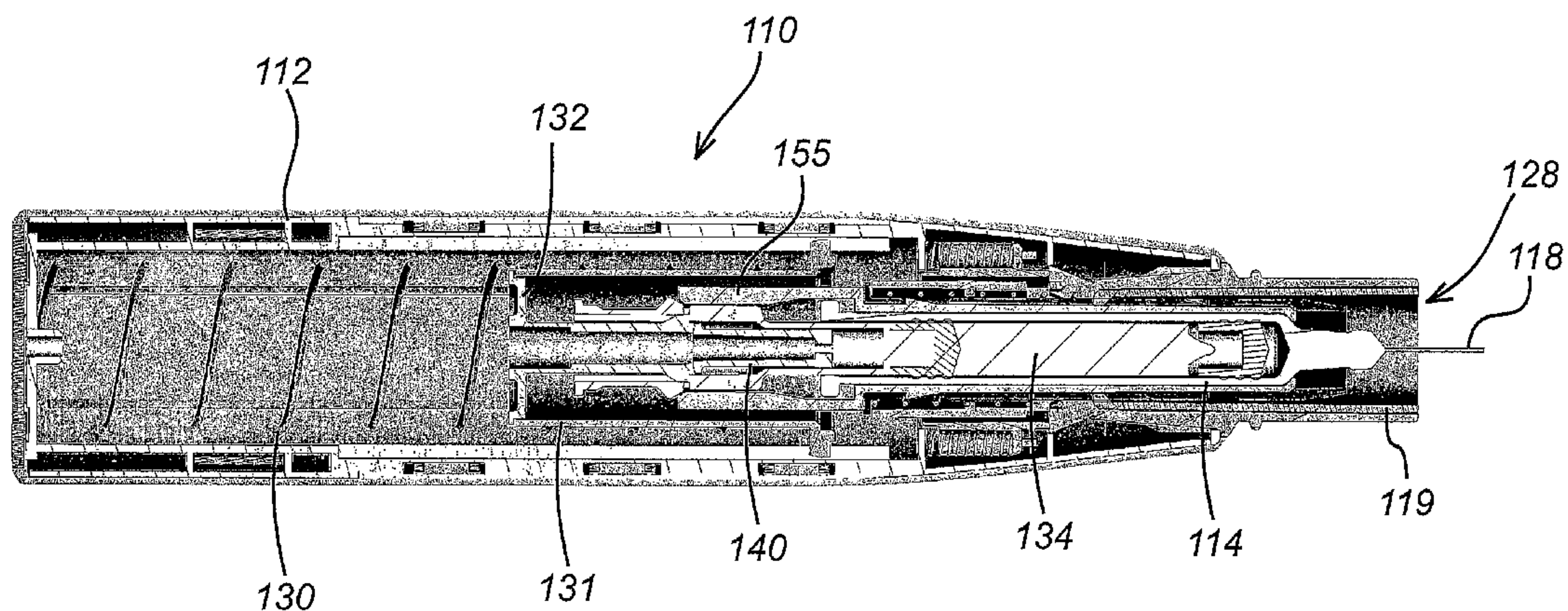

(57) Abstract: An injection device (110) is described having a housing (112) that receives a syringe (114) having a needle (118), wherein the syringe is supported in a syringe carrier (150). The syringe and syringe carrier are biased by a return spring (126) from an extended position in which the needle (118) extends from the housing (112) through an exit aperture (128) to a retracted position in which it does not. A drive spring (130) acts via a drive to advance the syringe from its retracted position to its extended position and discharge its contents through the needle and a return spring, brought into play when the drive has reached a nominal return position, restores the syringe to its retracted position.

WO 2005/115507 A1

- 1 -

INJECTION DEVICE**BACKGROUND TECHNOLOGY**

5 The present invention relates to an injection device of the type that receives a syringe, extends it, discharges its contents and then retracts it automatically. Devices of this general description are shown in WO 95/35126 and EP-A-0 516 473 and tend to employ a drive spring and some form of release mechanism that releases the syringe from the influence of the drive spring once its contents are supposed to have been discharged, to allow it to be
10 retracted by a return spring.

Often, such injection devices are required to work with glass pre-filled syringes that were originally designed for manual use. Such glass syringes have a flange at their base to allow a user to grip the syringe. The substantial force produced by the drive spring is applied to
15 the piston of the syringe. This force is transferred to the housing and return spring, via the flange. The flanges are not precision moulded and consequently have low manufacturing tolerances. They are not sufficiently flat or consistent to be used as a satisfactory support means for the syringe through which the force of the drive spring is transferred to the housing and return spring.

20

In practice, these flanges have been seen to fail when the drive spring is employed and the force produced by the drive spring is applied, via the piston of the syringe, to the flange. In particular, these flanges have been seen to break off from the syringe, resulting in the syringe body being propelled from the front of the injection device, and the whole needle
25 being inserted into the user's body. Consequently, when the injection device is taken away from the user's body, a full, broken syringe is left dangling from the user's body. This is clearly dangerous because the user is left with a broken syringe, and consequently broken glass, dangling from their body. The user is also left without having had their correct dose of drug. Such a syringe failure is also, of course, unpleasant for any user, particularly those
30 that are squeamish.

SUMMARY OF THE INVENTION

The injection devices of the present invention are designed to deal with these problems.

5 An injection device according to the present invention comprises:

a housing adapted to receive a syringe having a relatively wide reservoir portion and a relatively narrow discharge nozzle, so that the syringe is movable between a retracted position in which the discharge nozzle is contained within the housing and an extended position in which the discharge nozzle extends from the housing through an exit
10 aperture;

a drive element that acts upon the syringe;

a drive that acts upon the drive element to advance the syringe from its retracted position to its extended position and discharge its contents through the discharge nozzle;

a syringe carrier for carrying the syringe as it is advanced and restraining its
15 advancement beyond its extended position,

wherein the syringe carrier is adapted to support the syringe between the reservoir portion and the discharge nozzle; characterised in that the syringe carrier comprises an annular portion which is adapted to act as part of a release mechanism and couple with the drive element in order to disconnect the drive element from the drive.

20

The syringe carrier may provide an interface between the syringe and the housing.

The syringe carrier may comprise an annular collet having an internal diameter that is smaller than an outer diameter of the reservoir portion of the syringe. The annular collet
25 may be adapted to support the syringe between the reservoir portion and the discharge nozzle. The annular collet may be a split annular collet.

The syringe carrier may further comprise a sheath for surrounding the reservoir portion of the syringe, having a first internal diameter along its length, and further having a first end
30 with a second internal diameter which is smaller than the first internal diameter so that the first end of the sheath is adapted to support the syringe between the reservoir portion and the discharge nozzle. The sheath may be split.

-2a-

By supporting the syringe close to its first end with the syringe carrier, any force applied to the housing by the drive spring is transferred to the housing via the first end of the syringe. No force is transferred via any flange of the syringe. The first end of the syringe has been found to be stronger than the flange of the syringe, and to be less prone to failure. In

- 3 -

particular, tests have been carried out in which impact loads have been applied to the piston of a filled syringe. In tests where the syringe was supported in a rubber buffer under the flange, a mass of 1.6 kg dropped from 50mm would almost always result in a broken syringe. In tests where the syringe was supported on a conical collet under the end of the syringe nearest to the discharge nozzle, the syringes would almost always withstand the same mass being dropped from 75mm. Generally, when the syringe was supported on a conical collet under the end of the syringe nearest to the discharge nozzle, multiple impacts were required for failure.

10 By surrounding the syringe with the syringe carrier close to its first end, if the syringe does fail, it will not be propelled from the end of the device because it will not be able to fit through the part of the syringe carrier which has a reduced diameter.

By providing a sheath that is split, the syringe can be inserted into the syringe carrier through the split of the sheath. Generally, syringes are provided with a boot which covers the discharge nozzle. The boot is generally of larger diameter than the body of the syringe. By providing a split sheath, the syringe can be inserted into the sheath, without having to remove the boot from the syringe. This is advantageous because it is a requirement that the discharge nozzle of the syringe remains sterile for as long as possible before the injection device is used.

The injection device may further comprise means for biasing the syringe from its extended position to its retracted position and a support for carrying the means for biasing the syringe. The syringe carrier may further comprise means for bearing against the support.

25 The means for bearing may comprise a portion having an external diameter which is greater than the external diameter of any portion of the syringe carrier situated between the means for bearing and the discharge nozzle.

The syringe carrier may further comprise a ramped surface, and the support may further comprise a corresponding locking surface, wherein the ramped surface is adapted to communicate with the locking surface so as to lock the syringe carrier relative to the support.

- 4 -

The injection device may further comprise a drive element and the syringe carrier may further comprise an annular portion which is adapted to act as part of a release mechanism and couple with the drive element in order to disconnect the drive element from the drive and allow the return spring to move the syringe from its extended position to its retracted
5 position.

BRIEF DESCRIPTION OF THE DRAWINGS

10 The invention will now be described by way of example with reference to the accompanying drawings, in which:

Figure 1 shows a cross-sectional view of an injection device according to the present invention; and

15

Figure 2 shows an enlarged part of the injection device shown in figure 1.

Figure 3 shows a perspective view of a syringe carrier for use in the present invention from a first direction;

20

Figure 4 shows a perspective view of the syringe carrier of figure 3 from a second direction.

25 DETAILED DESCRIPTION

Figures 1 and 2 show an injection device 110, having an injection device housing 112. The end of the housing 112 has an exit aperture 128, through which the end of a sleeve 119 can emerge.

30

The housing 112 contains a hypodermic syringe 114 of conventional type, including a syringe body 116 defining a reservoir and terminating at one end in a hypodermic needle 118 and at the other in a flange 120. The syringe body 116 is of substantially constant

diameter along the length of the reservoir, and is of significantly smaller diameter close to the end of the syringe which terminates in the hypodermic needle. A drive element 134 acts through the bung of the syringe to discharge the contents of the syringe 114 through the needle 118. This drive element 134 constrains a drug 124 to be administered within the
5 reservoir defined by syringe body 116. Whilst the syringe illustrated is of hypodermic type, this need not necessarily be so. Transcutaneous or ballistic dermal and subcutaneous syringes may also be used with the injection device of the present invention.

As illustrated, the syringe is housed within a syringe carrier 150. The syringe carrier is best
10 seen in figures 3 and 4. The syringe carrier 150 has a first end 151 which has a reduced diameter. The first end 151 of the syringe carrier supports the end of the syringe 114 nearest to the hypodermic needle. Close to the other end of the syringe carrier 150, are provided a pair of ramped projections 152. The pair of ramped projections 152 communicate with a corresponding pair of locking apertures on a return spring support 160
15 so that the syringe carrier 150 cannot move relative to the return spring support 160. The syringe carrier 150 also comprises a bearing surface 153 close to its second end, against which a corresponding bearing surface of the return spring support 160 is biased by a return spring 126. The return spring 126, via the return spring support 160 and the syringe carrier 150 biases the syringe 114 from an extended position in which the needle 118 extends
20 from the aperture 128 in the housing 112 to a retracted position in which the needle 118 is contained within the housing 112.

The syringe carrier 150 comprises a sheath 154 which is split along its length so that the syringe 114 can be clipped into the syringe carrier 150. The syringe 114 is provided with a
25 boot (not shown). By providing a syringe carrier 150 in the form of a split sheath 154, the syringe 114 can be inserted into the syringe carrier 150 and in turn into the injection device 110 without having to remove the boot from the syringe 114. Furthermore, if the syringe were to fail or break, the sheath 154, which substantially surrounds the syringe 114 along its length, would contain the broken pieces of syringe and reduce the likelihood of them
30 from escaping from the injection device.

The housing is further provided with a resilient latch member 161 that is biased into a position in which it engages a locking surface 163 on the return spring support 160. Before

engaging the locking surface 163, the latch member 161 also extends through a latch opening 165 in the sleeve 119. The latch member 161 includes a ramped surface 167 against which an edge of the latch opening 165 acts in the manner of a cam acting on a cam follower.

5

The housing also includes an actuator, and a drive which here takes the form of a compression drive spring 130. Drive from the drive spring 130 is transmitted via a multi-component drive to the piston of the syringe 114 to advance the syringe from its retracted position to its extended position and discharge its contents through the needle 118. The drive
10 accomplishes this task by acting directly on the drug 124 and the syringe 114. Static friction between the drive element 134 and the syringe body 116 initially ensures that they advance together, until the return spring 126 bottoms out or the syringe body 116 meets some other obstruction (not shown) that retards its motion.

15 The multi-component drive between the drive spring 130 and the syringe 114 consists of three principal components. A drive sleeve 131 takes drive from the drive spring 130 and transmits it to a first drive element 132. This in turn transmits drive to the drive element 134 already mentioned.

20 The drive element 132 includes a hollow stem 140, the inner cavity of which forms a collection chamber 142 in communication with a vent 144 that extends from the collection chamber through the end of the stem 140. The second drive element 134 includes a blind bore 146 that is open at one end to receive the stem 140 and closed at the other. As can be
25 seen, the bore 146 and the stem 140 define a fluid reservoir 148, within which a damping fluid is contained.

A trigger (not shown) is provided on the housing 112 remote from the exit aperture 128. The trigger, when operated, serves to decouple the drive sleeve 131 from the housing 112, allowing it to move relative to the housing 112 under the influence of the drive spring 130.

30 The operation of the device is then as follows.

Initially, the return spring support 160, and consequently the syringe carrier 150 and syringe 114, are prevented from movement by the resilient latch member 161. By moving the

- 7 -

sleeve 119 in a direction into the housing 112, the edge of the latch opening 165 is brought into contact with the ramped surface 167 of the latch member 161, causing the latch member 161 to move outwards and thus to disengage from the return spring support 160. Once the latch member 161 has disengaged from the locking surface 163, the syringe is
5 free to move.

The actuator is then depressed and the drive spring 130 is released. The drive spring 130 moves the drive sleeve 131, the drive sleeve 131 moves the first drive element 132 and the first drive element 132 moves the second drive element 134. The second drive element 134
10 moves and, by virtue of static friction and hydrostatic forces acting through the drug 124 to be administered, moves the syringe body 114 against the action of the return spring 126. The syringe body 114 moves the syringe carrier 150, which in turn moves the return spring support 160 and compresses the return spring 126. The hypodermic needle 118 emerges from the exit aperture 128 of the housing 112. This continues until the return spring 126
15 bottoms out or the syringe body 116 meets some other obstruction (not shown) that retards its motion. Because the static friction between the second drive element 134 and the syringe body 116 and the hydrostatic forces acting through the drug 124 to be administered are not sufficient to resist the full drive force developed by the drive spring 130, at this point the second drive element 134 begins to move within the syringe body 116 and the
20 drug 124 begins to be discharged. Dynamic friction between the second drive element 134 and the syringe body 116 and hydrostatic and hydrodynamic forces now acting through the drug 124 to be administered are, however, sufficient to retain the return spring 126 in its compressed state, so the hypodermic needle 118 remains extended.

25 Before the second drive element 134 reaches the end of its travel within the syringe body 116, so before the contents of the syringe have fully discharged, flexible latch arms linking the first and second drive elements 132, 134 reach a constriction within the housing 112 formed by an annular portion 155 at the end of the syringe carrier which is nearest to the flange 120 of the syringe 114. The constriction moves the flexible latch arms to a position
30 so that they no longer couple the first drive element 132 to the second drive element 134. Once this happens, the first drive element 132 acts no longer on the second drive element 134, allowing the first drive element 132 to move relative to the second drive element 134.

- 8 -

Because the damping fluid is contained within a reservoir 148 defined between the end of the first drive element 132 and the blind bore 146 in the second drive element 134, the volume of the reservoir 146 will tend to decrease as the first drive element 132 moves relative to the second drive element 134 when the former is acted upon by the drive spring 5 130. As the reservoir 148 collapses, damping fluid is forced through the vent 144 into the collection chamber 142. Thus, once the flexible latch arms have been released, some of the force exerted by the drive spring 130 does work on the damping fluid, causing it to flow through the constriction formed by the vent 144; the remainder acts hydrostatically through the fluid and through friction between the first and second drive elements 132, 134, thence 10 via the second drive element 134. Consequently, the second drive element 134 continues to move within the syringe body 116 and the drug 124 continues to be discharged. Losses associated with the flow of the damping fluid do not attenuate the force acting on the body of the syringe to a great extent. Thus, the return spring 126 remains compressed and the hypodermic needle remains extended.

15

After a time, the second drive element 134 completes its travel within the syringe body 116 and can go no further. At this point, the contents of the syringe 114 are completely discharged and the force exerted by the drive spring 130 acts to retain the second drive element 134 in its terminal position and to continue to cause the damping fluid to flow 20 through the vent 144, allowing the first drive element 132 to continue its movement.

Before the reservoir 148 of fluid is exhausted, flexible latch arms linking the drive sleeve 131 with the first drive element 132 reach another constriction within the housing 112. The constriction moves the flexible latch arms so that they no longer couple the drive sleeve 25 131 to the first drive element 132. Once this happens, the drive sleeve 131 acts no longer on the first drive element 132, allowing them to move relative each other. At this point, the forces developed by the drive spring 130 are no longer being transmitted to the syringe 114. The only force acting on the syringe will be the return force from the return spring 126 which acts on the end of the syringe 114 nearest to the needle 118 via the return spring 30 support 160 and the syringe carrier 150. Consequently, the syringe is returned to its retracted position and the injection cycle is complete.

CLAIMS

1. An injection device comprising:
 - a housing adapted to receive a syringe having a relatively wide reservoir portion and a relatively narrow discharge nozzle, so that the syringe is movable between a retracted position in which the discharge nozzle is contained within the housing and an extended position in which the discharge nozzle extends from the housing through an exit aperture;
 - a drive element that acts upon the syringe;
 - a drive that acts upon the drive element to advance the syringe from its retracted position to its extended position and discharge its contents through the discharge nozzle;
 - a syringe carrier for carrying the syringe as it is advanced and restraining its advancement beyond its extended position,wherein the syringe carrier is adapted to support the syringe between the reservoir portion and the discharge nozzle; characterised in that the syringe carrier comprises an annular portion which is adapted to act as part of a release mechanism and couple with the drive element in order to disconnect the drive element from the drive.
2. An injection device according to claim 1, wherein the syringe carrier provides an interface between the syringe and the housing.
3. An injection device according to claim 1 or claim 2 wherein the syringe carrier comprises an annular collet having an internal diameter that is smaller than an outer diameter of the reservoir portion of the syringe, wherein the annular collet is adapted to support the syringe between the reservoir portion and the discharge nozzle.
4. An injection device according to claim 3 wherein the annular collet is a split annular collet.
5. An injection device according to any one of claims 1 to 4 in which the syringe carrier comprises a sheath for surrounding the reservoir portion of the syringe, wherein the sheath has a first internal diameter along its length, and a first end with a second internal diameter which is smaller than the first internal diameter so that the first end of

the sheath is adapted to support the syringe between the reservoir portion and the discharge nozzle.

6. An injection device according to claim 5 in which the sheath is split along its length.

7. An injection device according to any one of claims 1 to 6 further comprising means for biasing the syringe from its extended position to its retracted position.

8. An injection device according to claim 7, further comprising a support for carrying the means for biasing the syringe.

9. An injection device according to claim 8, wherein the syringe carrier further comprises means for bearing against the support.

10. An injection device according to claim 9 in which the means for bearing comprises a portion having an external diameter which is greater than the external diameter of any portion of the syringe carrier situated between the means for bearing and the discharge nozzle.

11. An injection device according to any one of claims 8 to 10 in which the syringe carrier further comprises a ramped surface, and the support further comprises a corresponding locking surface, wherein the ramped surface is adapted to communicate with the locking surface so as to lock the syringe carrier relative to the support.

FIG. 1

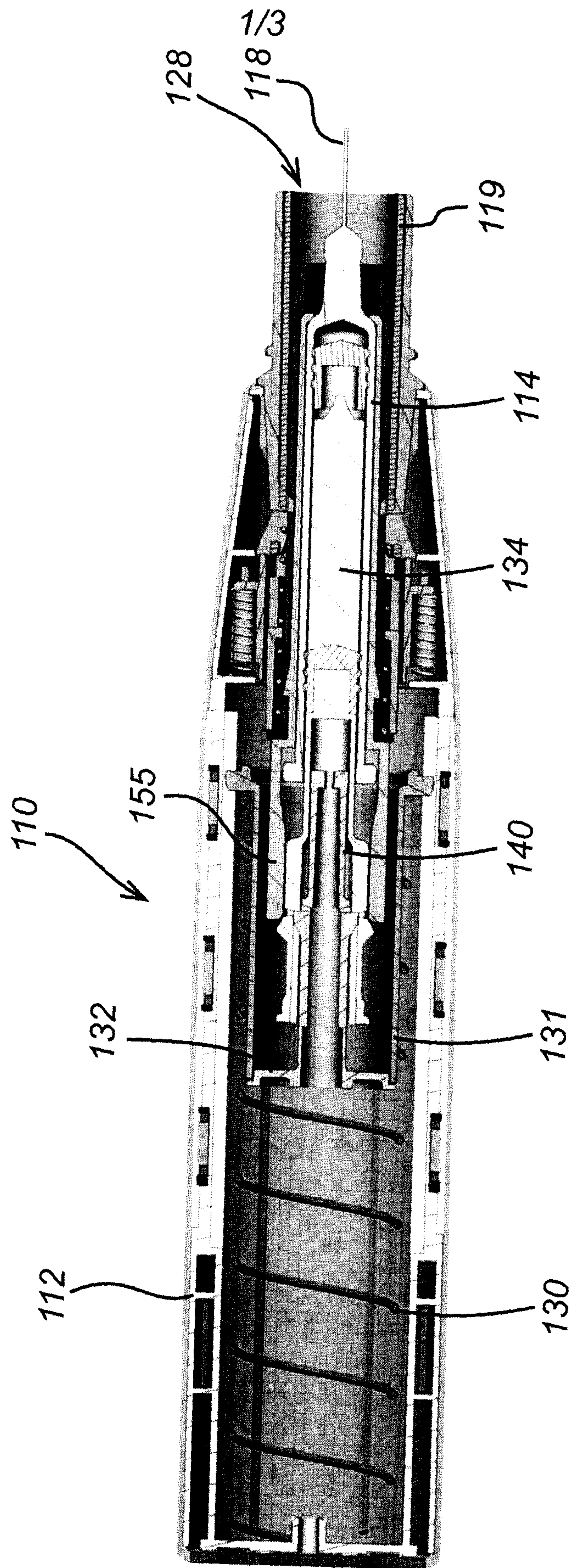
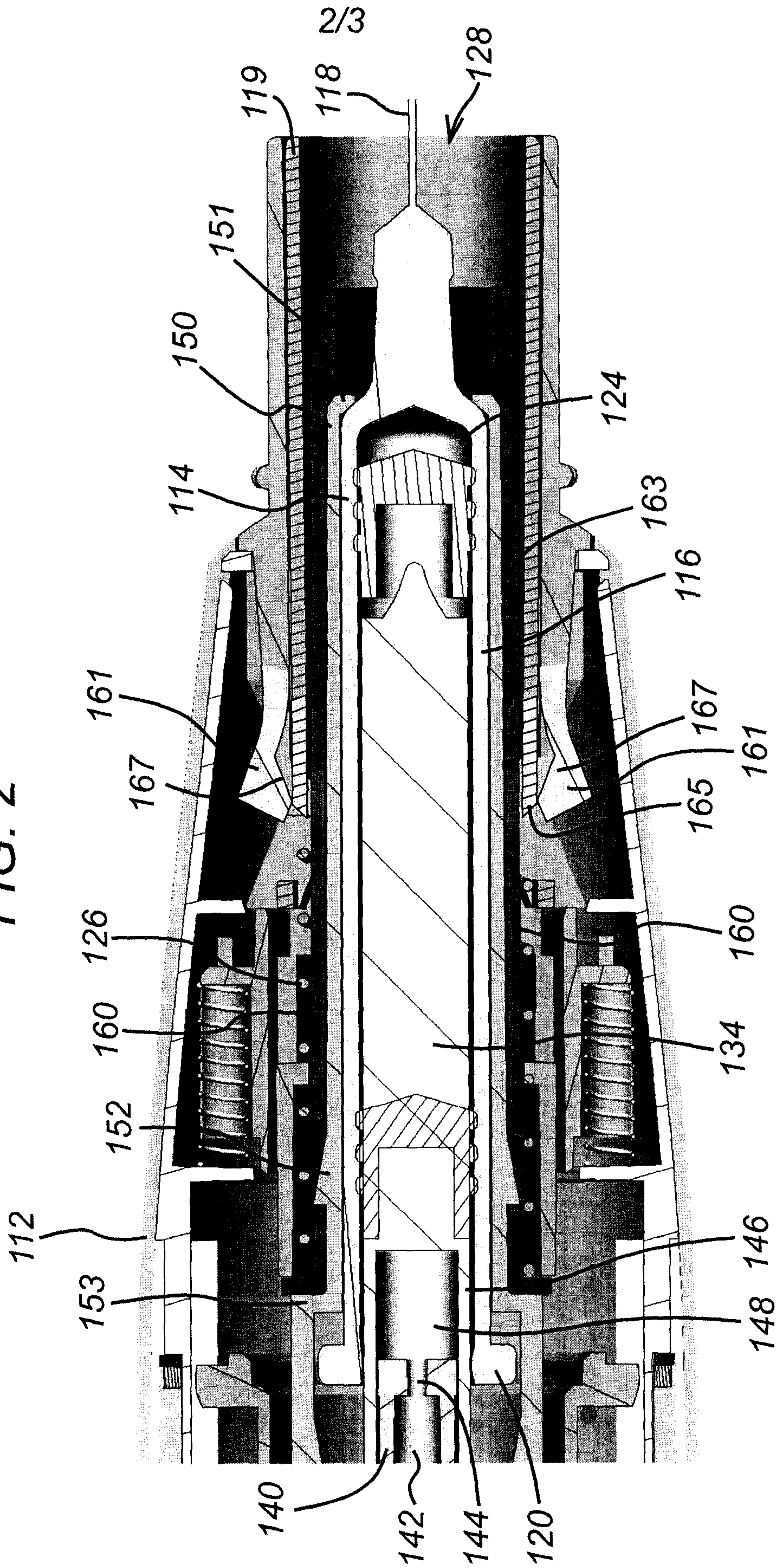

FIG. 2



3/3

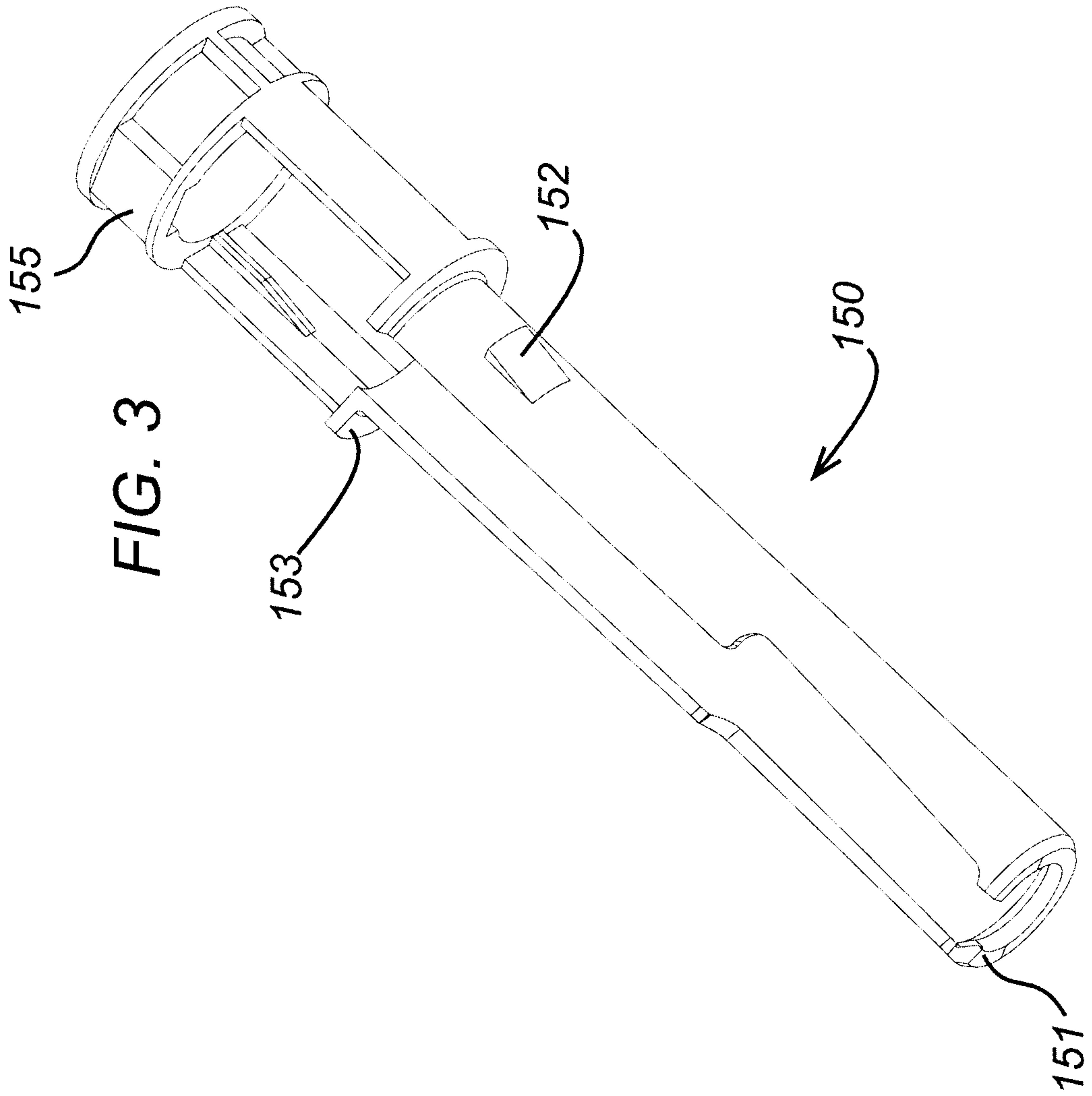
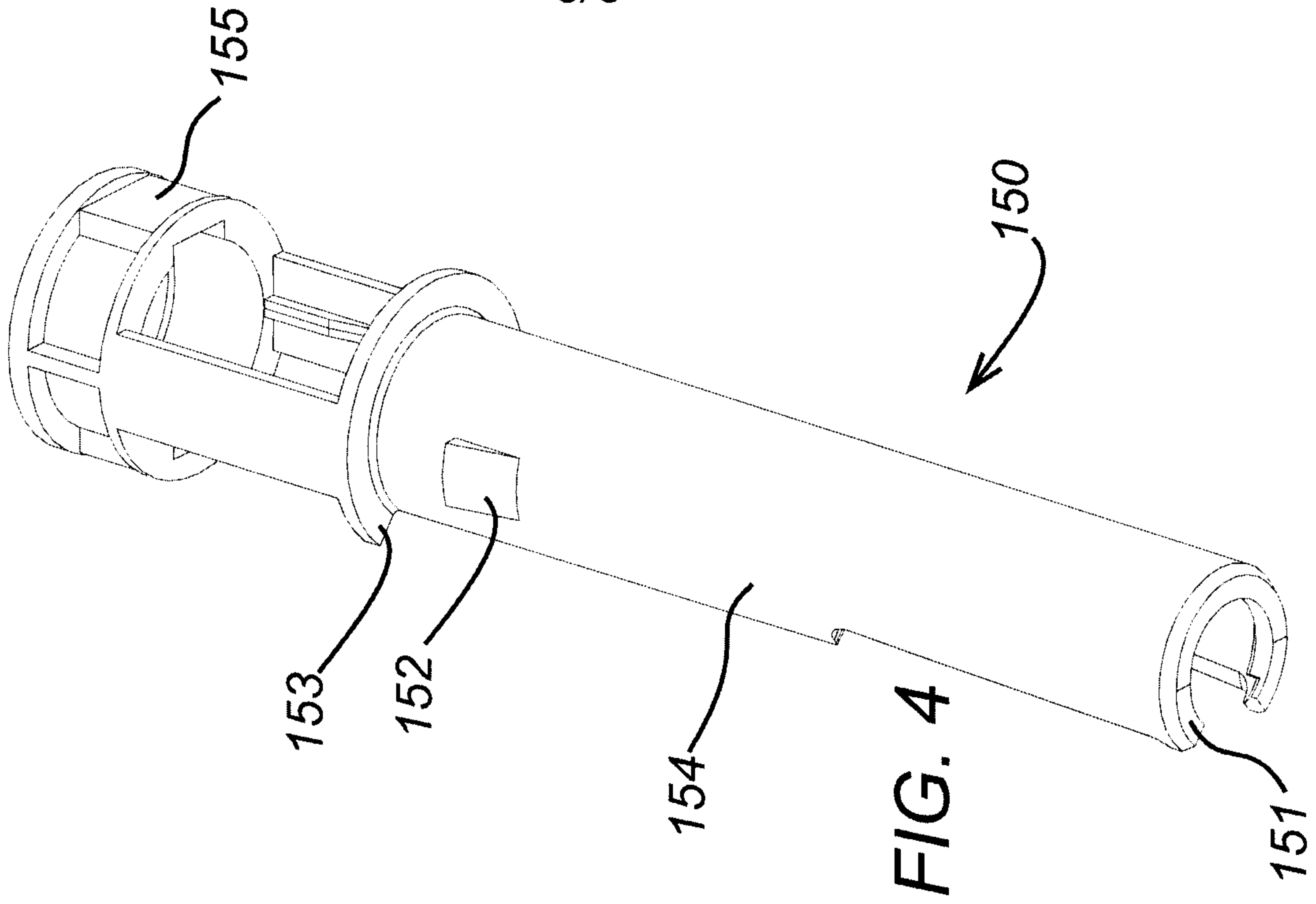

FIG. 3

FIG. 4

