



(19) **United States**

(12) **Patent Application Publication**
MacKenzie et al.

(10) **Pub. No.: US 2012/0035548 A1**

(43) **Pub. Date: Feb. 9, 2012**

(54) **SYSTEM AND METHOD FOR ESTABLISHING VASCULAR ACCESS**

Publication Classification

(75) Inventors: **Andrew J. MacKenzie**, Santa Clara, CA (US); **John E. Carlson**, San Jose, CA (US)

(51) **Int. Cl.**
A61M 29/00 (2006.01)
A61B 17/34 (2006.01)

(52) **U.S. Cl.** **604/164.1**

(73) Assignee: **Tyco Healthcare Group LP**

(57) **ABSTRACT**

(21) Appl. No.: **13/272,276**

(22) Filed: **Oct. 13, 2011**

Systems, kits, and methods for establishing vascular access are described. A system typically includes a radially expandable sleeve, a dilator, and a guidewire. The methods comprise positioning the guidewire through an initial tissue tract, passing the radially expandable sleeve over the guidewire through the tissue tract to a target blood vessel, and thereafter passing the dilator over the guidewire and through the radially expandable sleeve to effect radial expansion of the sleeve. Use of the sleeve reduces the risk of injuring tissue surrounding the tissue tract by lessening the axial forces imparted to the tissue. Kits comprise at least the radially expandable sleeve together with instructions for use.

Related U.S. Application Data

(60) Division of application No. 10/704,073, filed on Nov. 5, 2003, now abandoned, which is a division of application No. 09/735,282, filed on Dec. 11, 2000, now Pat. No. 6,692,462, which is a continuation-in-part of application No. 09/314,878, filed on May 19, 1999, now abandoned.

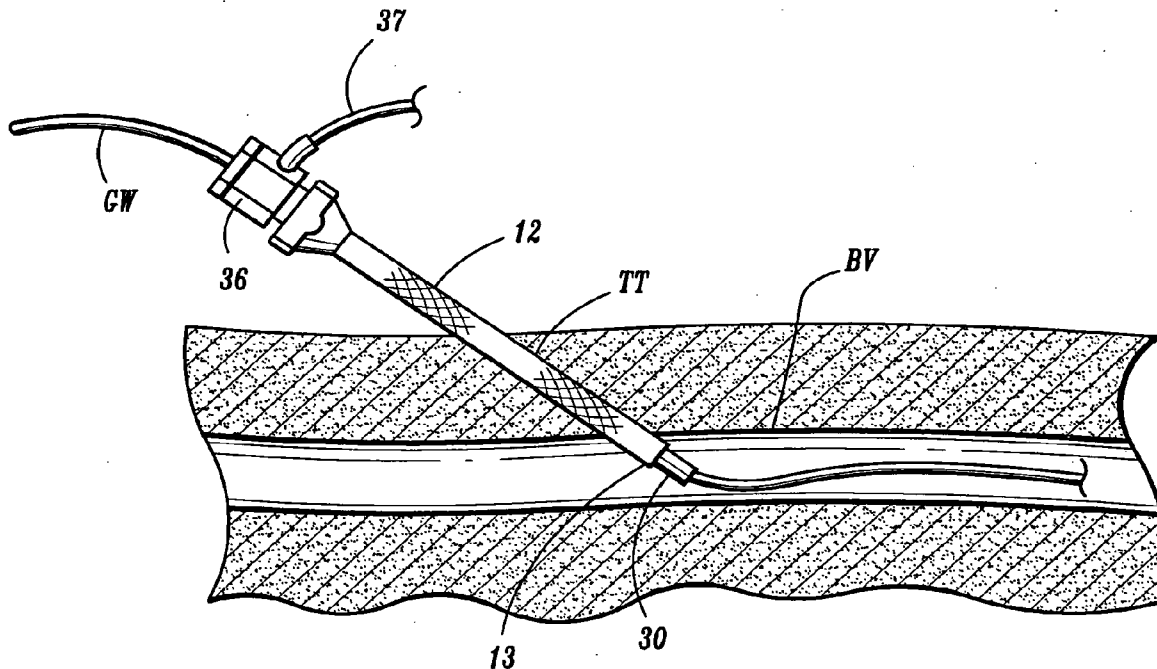

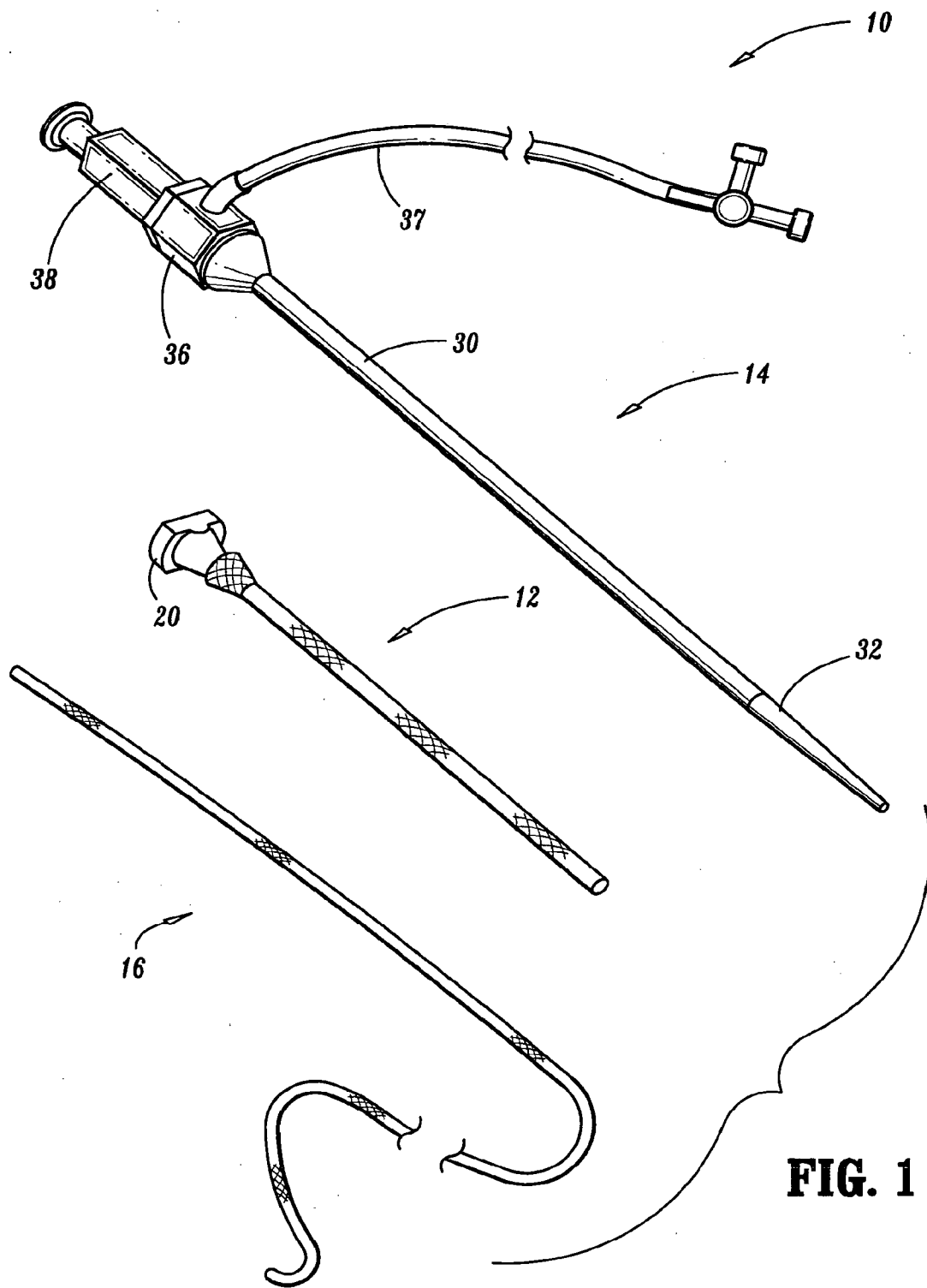

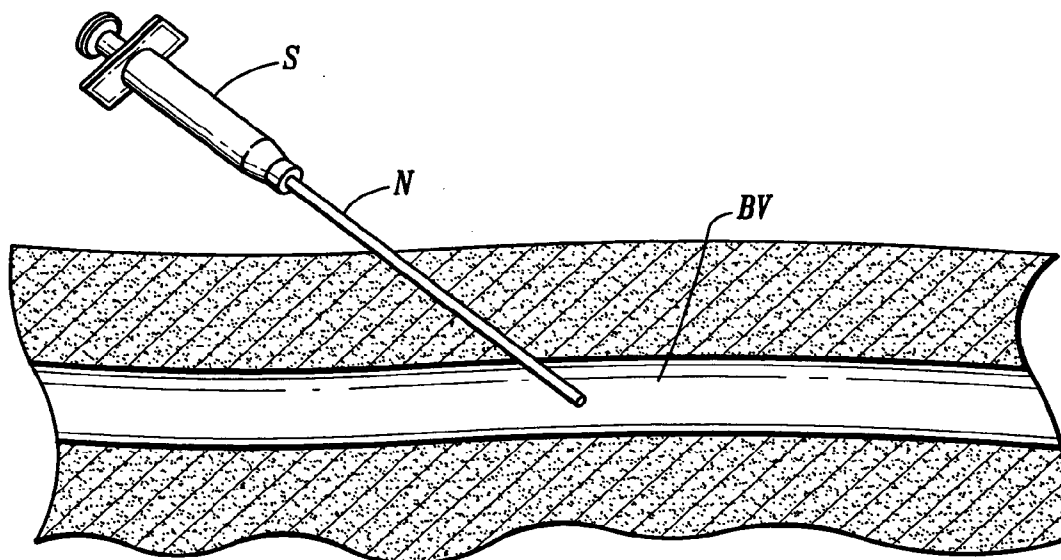

FIG. 2A

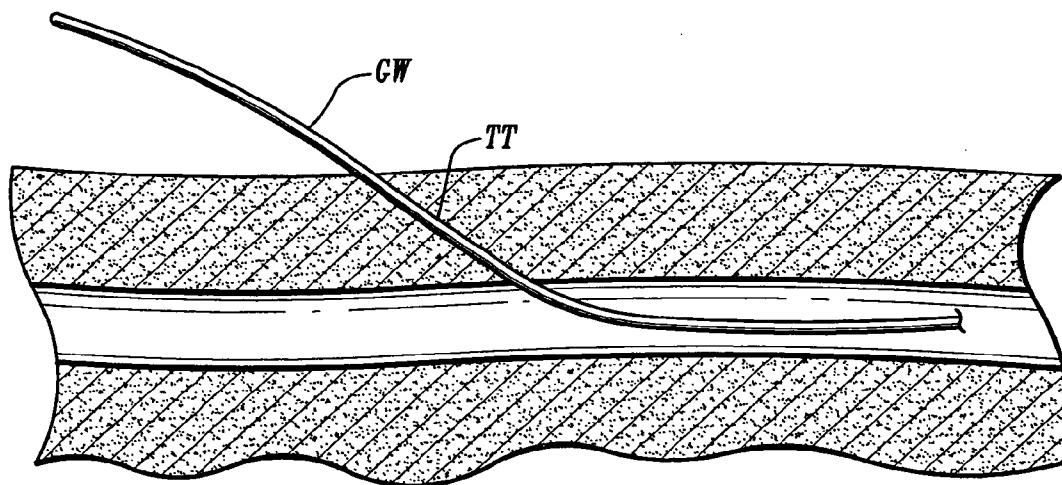

FIG. 2B

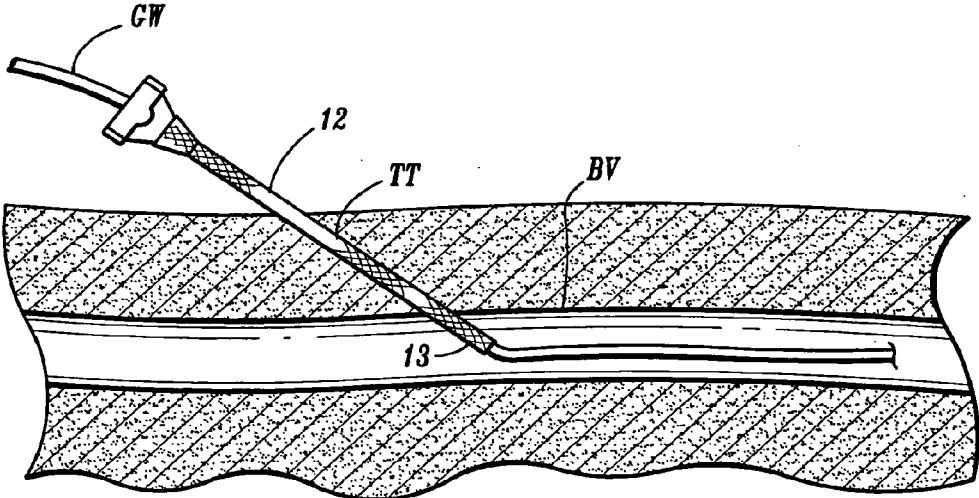

FIG. 2C

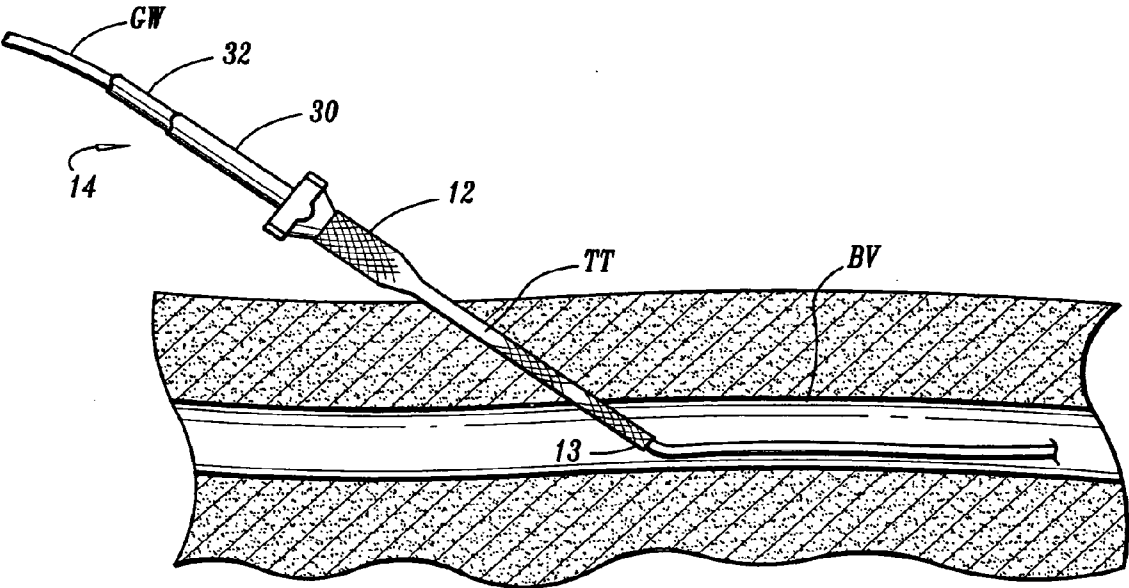

FIG. 2D

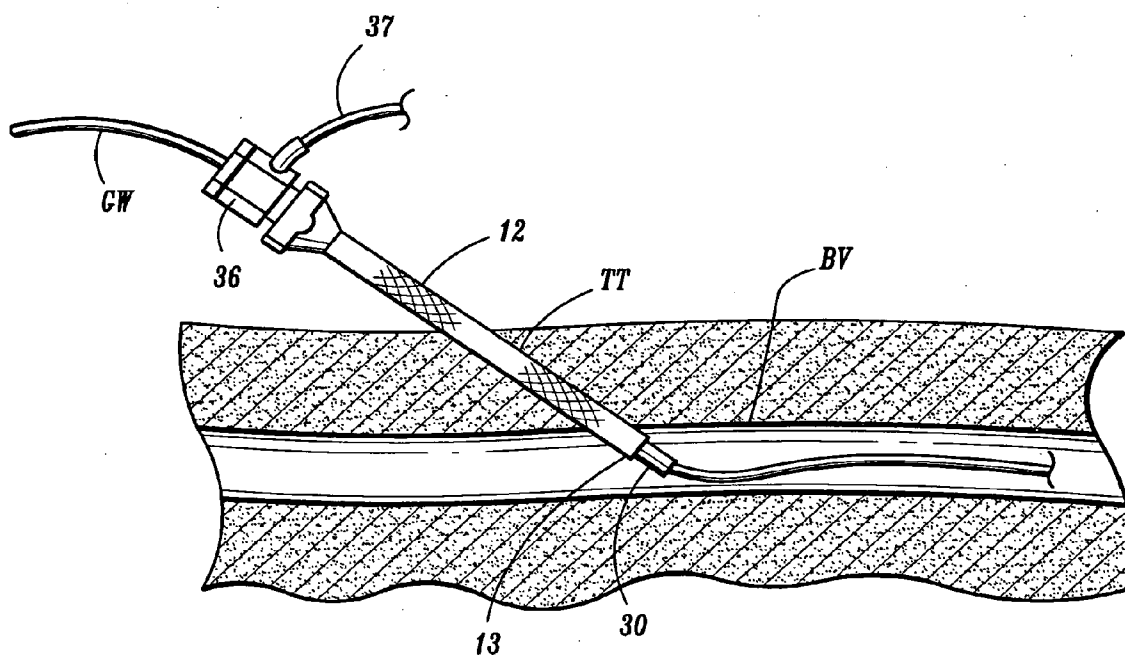

FIG. 2E

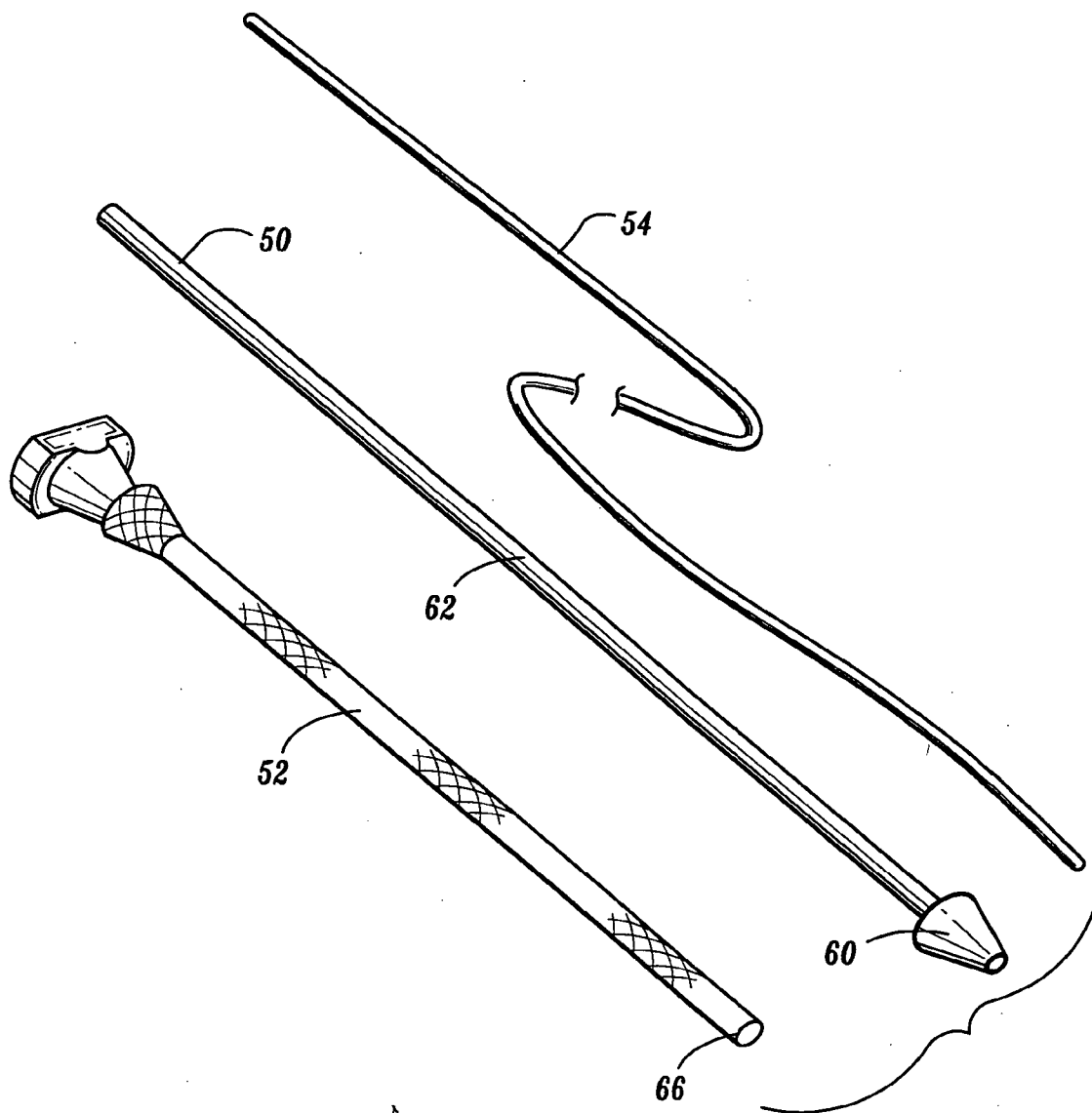

FIG. 3

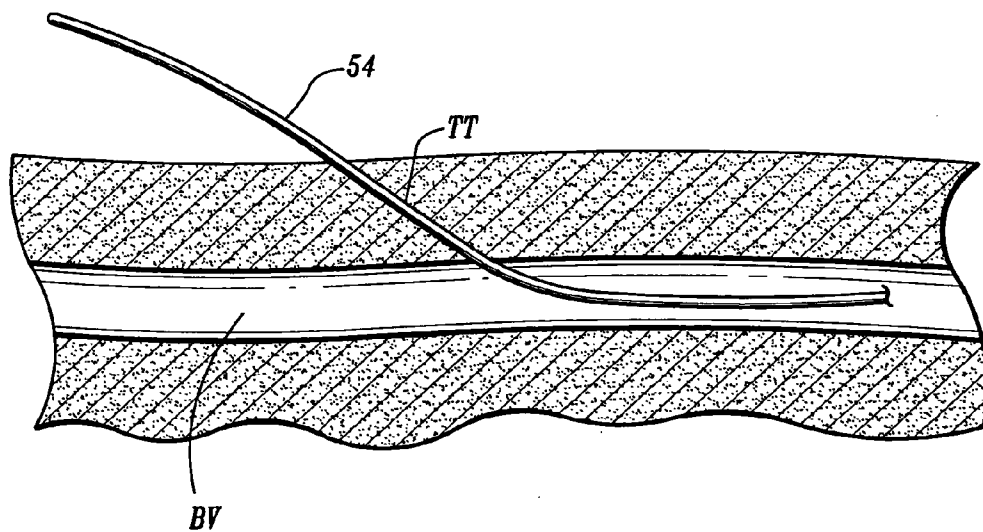

FIG. 4A

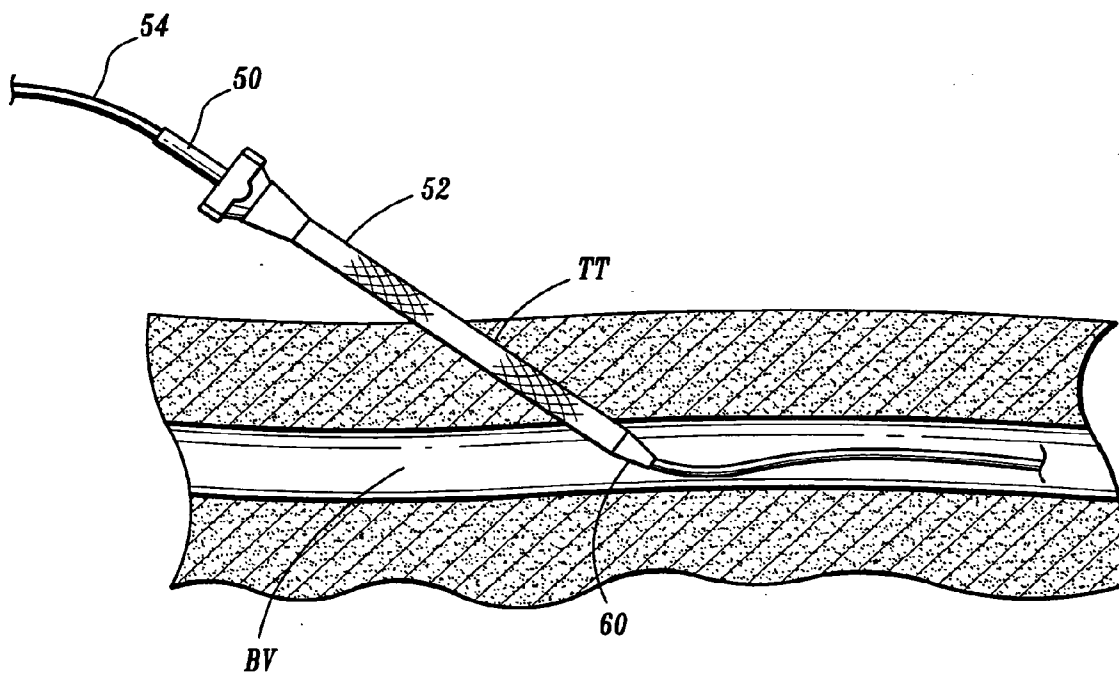

FIG. 4B

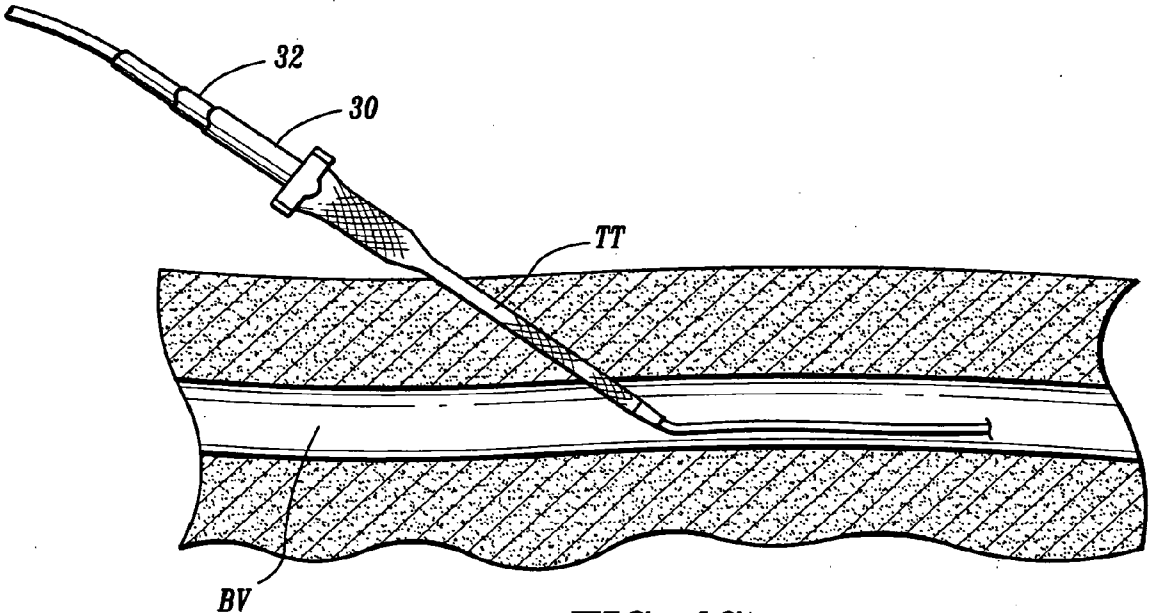

FIG. 4C

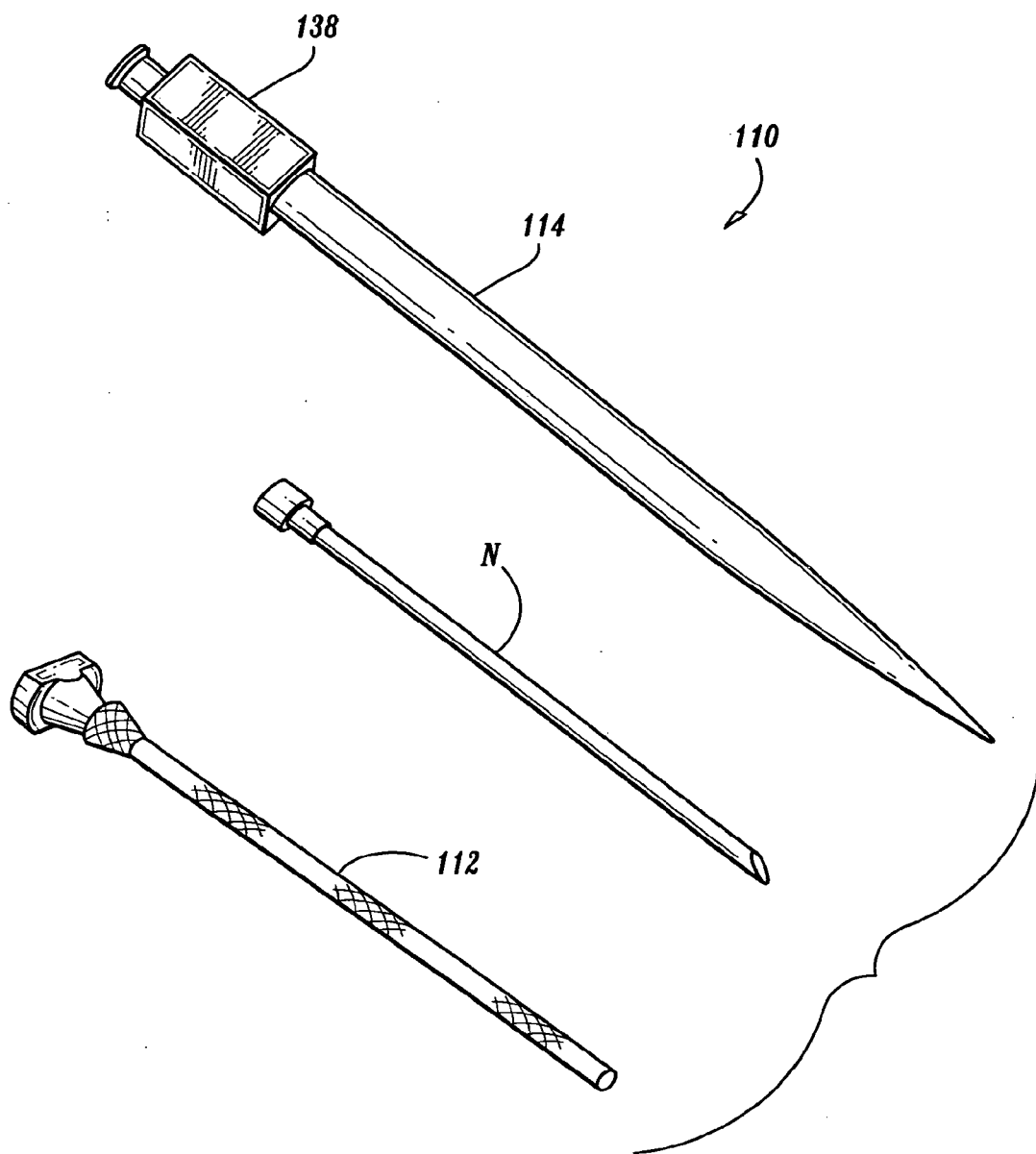

FIG. 5

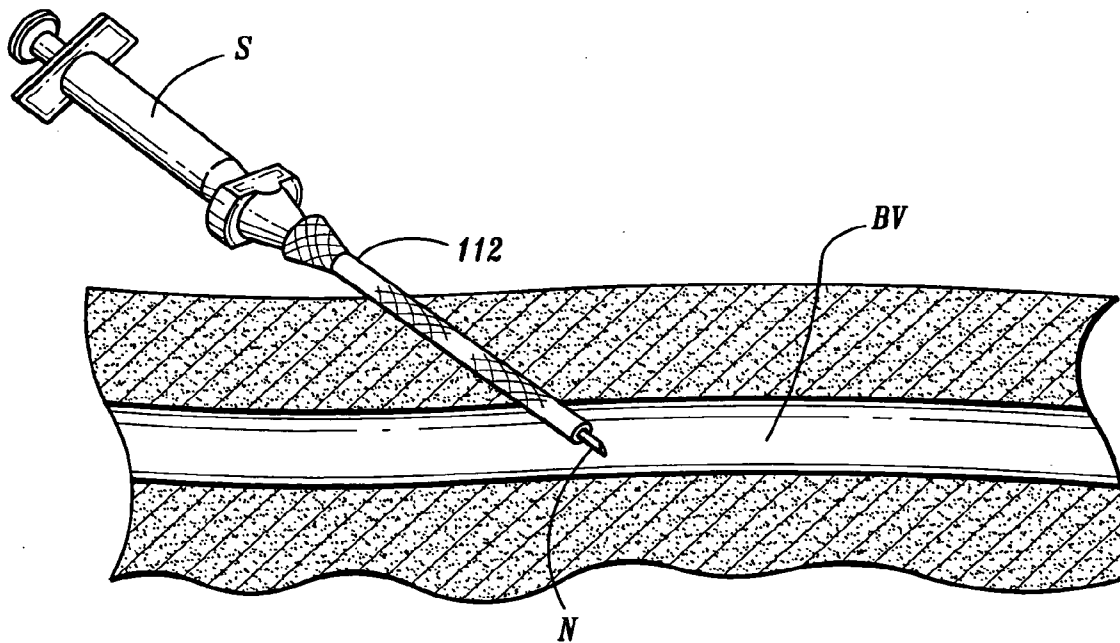

FIG. 6A

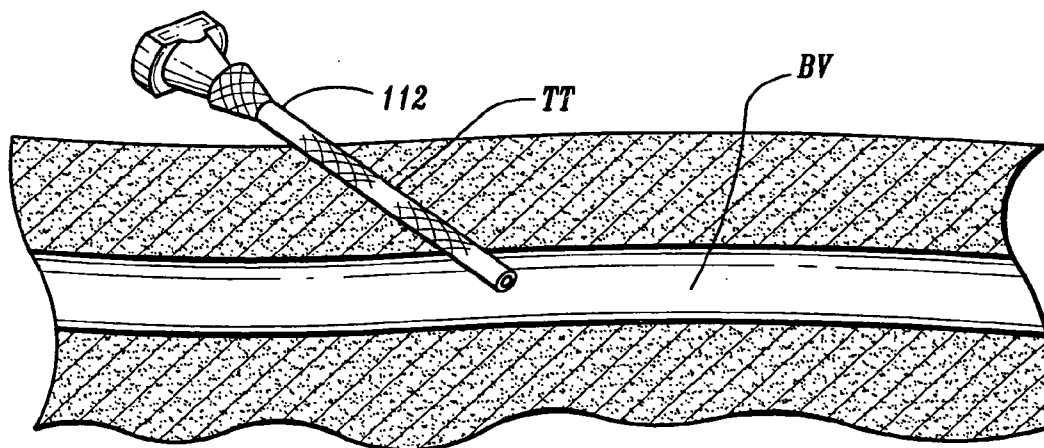

FIG. 6B

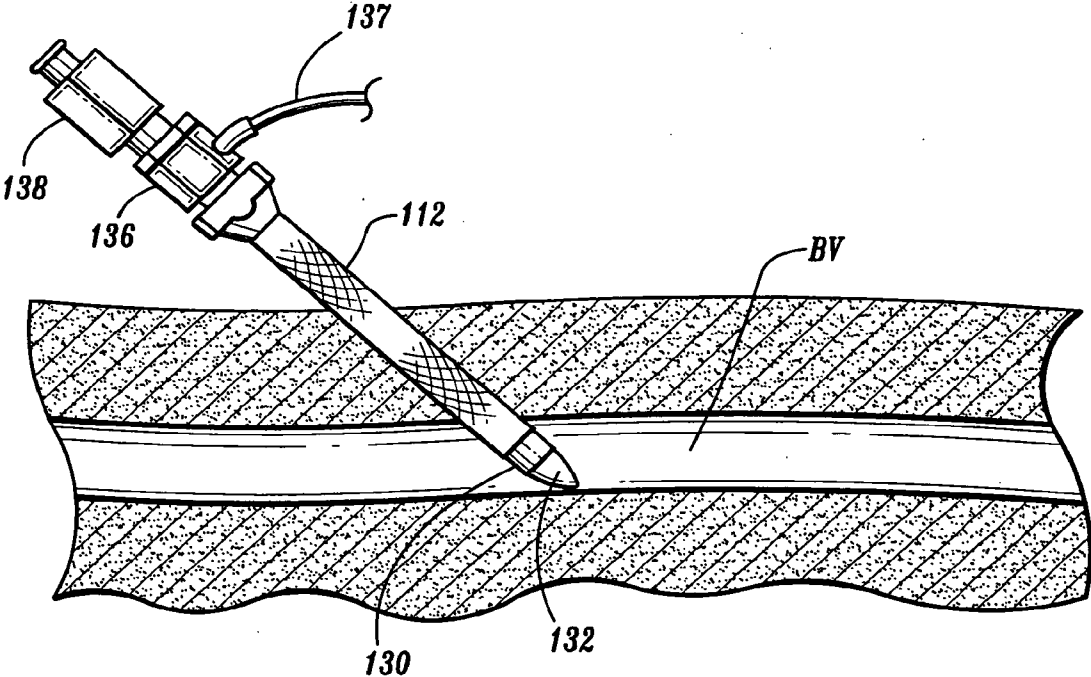

FIG. 6C

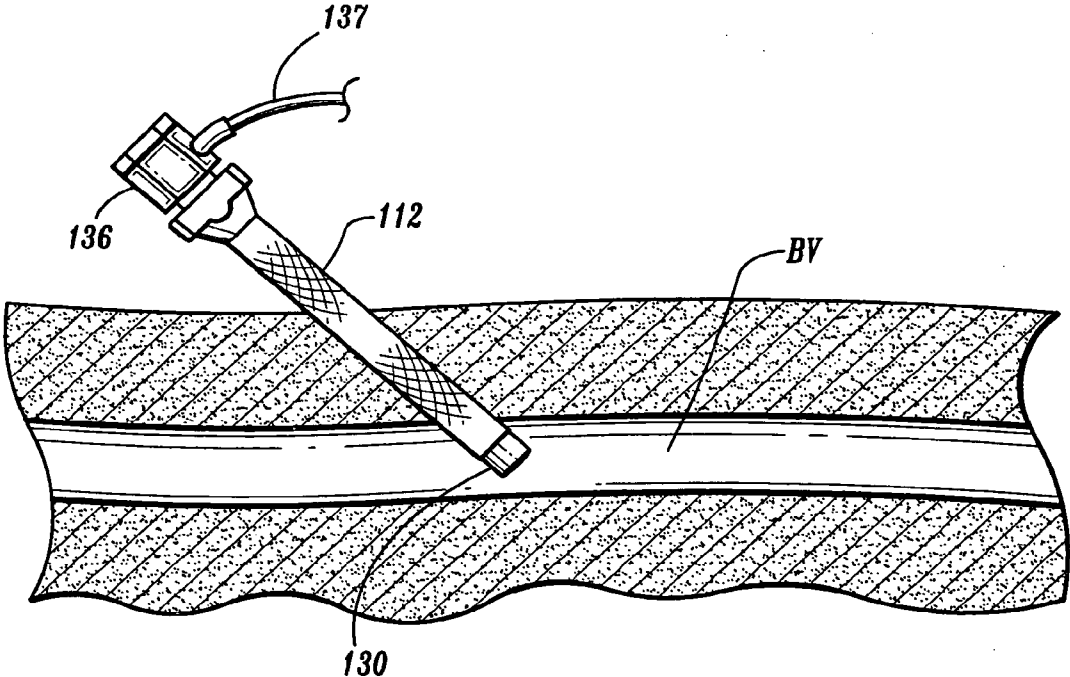

FIG. 6D

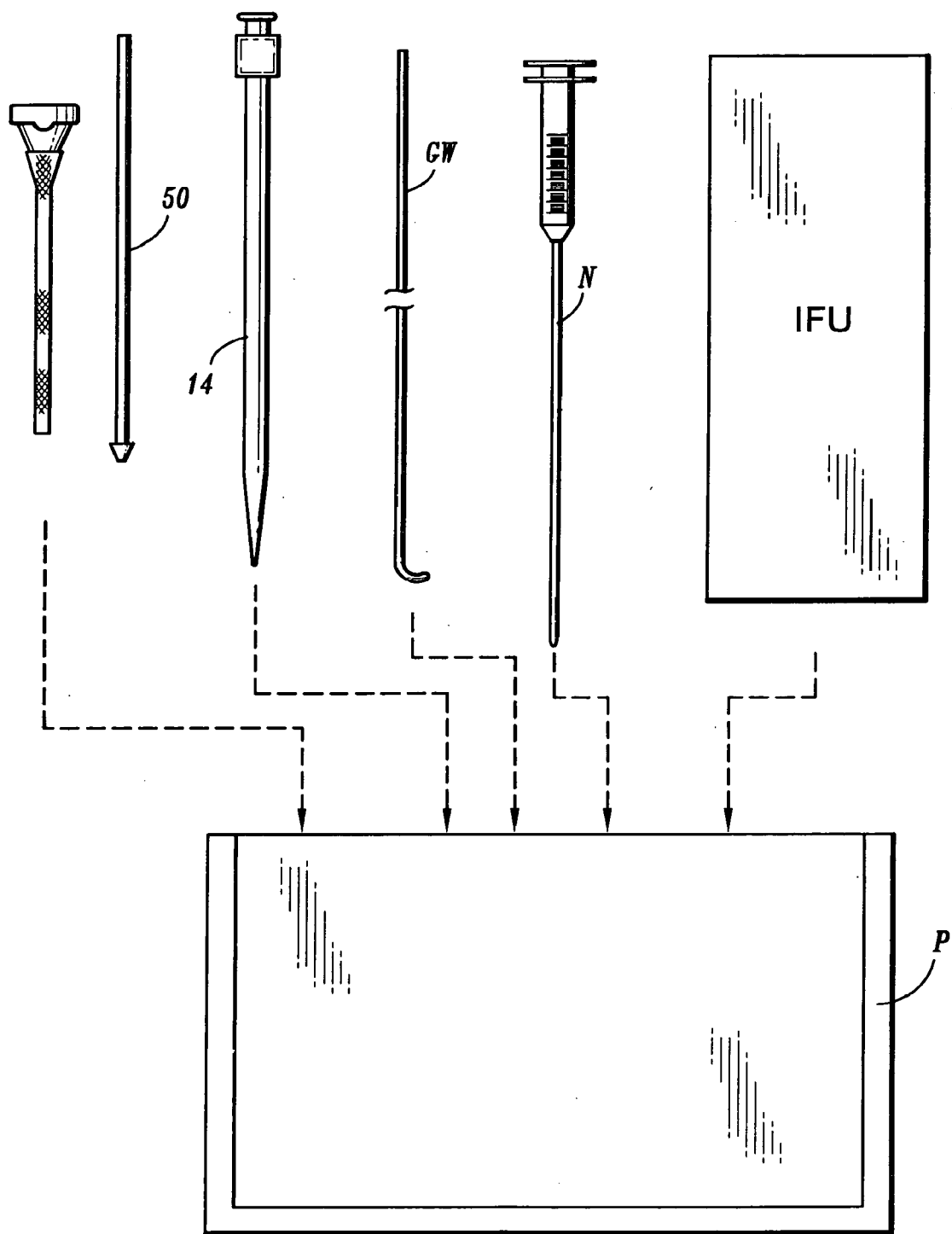

FIG. 7

SYSTEM AND METHOD FOR ESTABLISHING VASCULAR ACCESS

CROSS-REFERENCES TO RELATED APPLICATIONS

[0001] This application is a Divisional Application which claims the benefit of and priority to U.S. application Ser. No. 10/704,073, filed on Nov. 5, 2003, which is a Divisional Application which claims the benefit of and priority to U.S. application Ser. No. 09/735,282, filed on Dec. 11, 2000, now U.S. Pat. No. 6,692,462, which is a Continuation-in-Part Application which claims the benefit of and priority to U.S. application Ser. No. 09/314,878, filed on May 19, 1999, the full disclosures of each of which being incorporated herein by reference.

BACKGROUND OF THE INVENTION

[0002] 1. Field of the Invention

[0003] The present invention relates generally to medical devices and medical methods. In particular, the present invention relates to systems, kits, and techniques for establishing percutaneous vascular access.

[0004] Access to patient blood vessels is necessary for a wide variety of diagnostic and therapeutic purposes. For example, intravascular catheters are introduced to both the arterial vasculature and the venous vasculature, typically using either surgical cut down techniques or percutaneous introduction techniques. Of particular interest to the present invention, the most common percutaneous introduction technique is referred to as the Seldinger technique. While a wide variety of variations exist, the basic Seldinger technique relies on initially accessing a target blood vessel with a needle. A guidewire is then passed through the needle into the blood vessel, and the needle withdrawn over the guidewire. A dilator is then passed over a guidewire to enlarge the diameter of the tissue tract so that it can accommodate a larger introducer sheath. Once the introducer sheath is in place, access to the blood vessel can be reliably obtained through a lumen of the sheath.

[0005] With the introduction of a greater number and variety of intravascular techniques, including angioplasty, atherectomy, endovascular aneurysm repair, minimally invasive cardiac surgery, and the like, a need has arisen to provide relatively large diameter access to the vasculature. Thus, access sheaths having a diameter of 24 French (8 mm) or greater are now commonly introduced using the Seldinger or other percutaneous techniques. As the number and size of procedures increase, so does the risk of complications which place individual patients at risk and which are costly to the healthcare system.

[0006] As larger and larger access diameters are sought, the need to dilate the tissue tract becomes greater. The use of conventional dilators, however, can significantly traumatize the skin. In particular, advancement of a conventional dilator through a tissue tract exerts significant axial forces on the tissue, potentially causing injury and delamination of adjacent tissue layers.

[0007] For these reasons, it would be desirable to provide improved systems, kits, and methods for establishing percutaneous vascular access for catheterization and other vascular procedures. In particular, it would be desirable to provide vascular access techniques which could dilate a percutaneous tissue tract with minimum trauma to tissue surrounding the

tract. Such techniques should be suitable for forming large (as well as small) diameter access channels, typically having diameters as large as 6 mm, preferably as large as 8 mm, or larger. It would be still further desirable if the improved systems, kits, and methods would require little modification of existing techniques and systems for establishing vascular access. At least some of these objectives will be met by the inventions described hereinafter.

[0008] 2. Description of the Background Art

[0009] The use of radially expanding dilators for accessing non-vascular body locations is described in U.S. Pat. Nos. 5,814,058; 5,431,676, 5,183,464, and copending application Ser. No. 08/424,696, all of which are commonly assigned with the present application and the full disclosures of which are incorporated herein by reference. U.S. Pat. No. 5,230,705, describes use of a needle disposed within a dilation structure for use in intravenous catheterization. See also U.S. Pat. Nos. 5,312,417; 5,246,424; 5,201,756, 5,139,511, and 4,899,729.

SUMMARY OF THE INVENTION

[0010] The present invention provides improved systems, kits, and methods for establishing percutaneous access to a patient's vasculature. Access can be established to a variety of particular blood vessels, including both arteries and veins, such as the femoral artery, radial artery, and the like. The purpose for accessing the vasculature can be diagnostic, such as angiography, intravascular ultrasound, cardiac mapping, or the like, or can be therapeutic, such as angioplasty, atherectomy, minimally invasive cardiac surgeries, endovascular aneurysm repair, cardiac ablation, or the like.

[0011] The methods of the present invention comprise particular improvements over the Seldinger technique, as described above, employing a sheath dilator for expanding an initial needle penetration to a target blood vessel. As set forth in the Background section, use of a dilator/sheath assembly directly within a tissue tract can subject the tissue to significant axial forces which can delaminate or otherwise damage the tissue surrounding the tissue tract.

[0012] The present invention reduces the risk of injuring the tissue by introducing a radially expandable sleeve over a guidewire which has been placed through the tissue tract using otherwise conventional techniques. The radially expandable sleeve will be immobilized (typically being manually held) relative to the tissue tract so that axial advancement of a sheath/dilator or other dilating member through the radially expandable sleeve will impart little or no axial force to the underlying tissue. Instead, only radially expansive forces will be transmitted outwardly through the sleeve.

[0013] Systems according to the present invention for establishing vascular access over a guidewire comprise a dilator and a radially expandable sleeve. The dilator has a lumen sized to be introduced over the guidewire. The guidewire will have a pre-selected diameter which is generally constant over its entire length. The diameter will be relatively small, typically being either 0.36 mm (0.014 in.) or 0.89 mm (0.035 in.), which are conventional sizes for guidewires used for vascular access. The lumen of the dilator will be sized slightly greater than the outside diameter of the guidewire with which it is to be used, typically being 0.46 mm (0.018 in.) or 1 mm (0.4 in.) for each of the guidewire sizes mentioned above. The dilator will have an outside diameter selected to provide for a desired degree of radial expansion of the tissue tract. Typically, the outside diameter of the dilator

will be in the range from 1 mm to 2.5 mm for the smaller guidewire size and 1.3 mm to 3.3 mm for the larger guidewire size.

[0014] The radially expandable sleeve will have a lumen therethrough and an unexpanded diameter which is only slightly greater than the diameter of the associated guidewire, e.g., 0.41 mm (0.016 in.) for the 0.36 mm (0.014 in.) guidewire and 0.96 mm (0.038 in.) for the 0.89 mm (0.035 in.) guidewire. Typically, the sleeve will have an outside diameter which is no more than 300% of the guidewire diameter, preferably being no more than 200% of the guidewire diameter. The sleeve, however, will have an expandable outer wall which permits the dilator to be introduced over the guidewire and through the sleeve to cause expansion. In a first embodiment, the outer wall of the radially expandable sleeve can be compliant or elastic so that its cross-section collapses after expansion if the dilator used for expansion is withdrawn. Typically, the compliant or elastic structure will be reinforced with a tubular braid, e.g., a braid formed as a mesh of non-elastic filaments where radial expansion will cause axial shortening of the braid. The braid may be embedded in the elastic or compliant layer or may be covered by the elastic or compliant layer.

[0015] Alternatively, the radially expandable sleeve may have a plastically deformable body or may comprise a locking structure so that it retains its expanded diameter after dilation. Typically, the plastically deformable radially expandable sleeves will also be reinforced with the braid. For example, the braid may be covered or impregnated with a suitable plastically deformable material, such as expanded PTFE, irradiated polyesters, and the like. As an alternative or an addition to use of the plastically deformable sleeve matrix, the braid reinforcement may be configured so that the braid filaments interlock upon radial expansion. Thus, the filaments in themselves will resist radial collapse after the sleeve has been expanded.

[0016] When the system employs an elastic or compliant radially expandable sleeve, it will be necessary to provide further system component(s) to retain the sleeve in its expanded configuration after the dilator has effected dilation. Conveniently, this can be accomplished using a conventional sheath/dilator assembly as the dilator. After the sleeve has been expanded (thus expanding the tissue tract), an inner portion of the assembly, usually referred to as the dilator, can be withdrawn from the sheath, leaving the sheath in place to maintain the expanded diameter of the tissue tract. While this is an effective approach and utilizes a device with which the treating physician is quite familiar, it has the disadvantage that the radially expandable sleeve adds a very small thickness to the diameter to which the tissue tract is expanded. Use of the plastically deformable or locking sleeve will, in contrast, allow use of a simple dilator, i.e., one without an associated sheath. Thus, there will be no additional structure and no need to dilate the tissue tract any more than would be required with a conventional sheath dilator.

[0017] Optionally, the system may further comprise a sleeve introducer adapted to facilitate introduction of the sleeve over a guidewire through the tissue tract. In some patients, conventional Seldinger and other access techniques can be difficult due to the presence of scar tissue or other complicating factors. In such cases, significant pushing force may be required to advance the sleeve over the guidewire. While the small profile of the introducer sleeve reduces the force necessary for introduction over the guidewire, in some

cases it will be desirable to still further reduce the introduction force. Such a reduction in introduction force can be accomplished by providing a tapered distal tip on the sleeve. While this could be done by modifying the design of the sleeve itself, it is more easily accomplished using a separate introducer sleeve having a tapered distal end a lumen therethrough. The sleeve is configured to receive a guidewire through its lumen and to be received within the lumen of the radially expandable sleeve. By then placing the radially expandable sleeve over the sleeve introducer, the temporary assembly of the sleeve and sleeve introducer can be introduced over the guidewire so that the tapered end of the sleeve introducer first advances through and dilates the tissue tract to reduce the necessary introduction force. After the distal end of the assembly reaches the blood vessel, the dilator may then be introduced over the assembly, i.e., the lumen of the dilator will pass over the exterior of the sleeve introducer. After dilation of the radially expansible sleeve is accomplished, the sleeve introducer and guidewire can then be removed from the expanded access channel defined by the dilator.

[0018] Methods according to the present invention for establishing vascular access comprise forming a percutaneous tissue tract to a target blood vessel. Typically the tissue tract is initially formed using a needle and guidewire according to conventional techniques, such as the first steps in a Seldinger access protocol. A guidewire is positioned in the tissue tract, and a radially expandable sleeve positioned over the guidewire and through the tissue tract so that a distal end of the sleeve lies in the blood vessel. A proximal end of the sleeve will remain outside the tissue tract, and the sleeve may then be expanded from a narrow diameter configuration to a larger diameter configuration to provide an access lumen to the blood vessel. In a first embodiment, the sleeve will be plastically deformable or otherwise capable of maintaining its larger diameter configuration, and expansion can be effected using a simple dilator without an associated sheath. In an alternative embodiment, the radially expandable sleeve will be elastic or compliant and expansion can be effected using a sheath dilator where the dilator is removed after expansion and the sheath left in place to maintain the desired access lumen. Usually, the radially expandable sleeve which is advanced over the guidewire will have an outer diameter which is no more than 300% larger than the guidewire diameter, preferably no more than 200% larger.

[0019] The present invention still further provides kits for performing any of the methods described herein. The kits will comprise at least a radially expandable sleeve together with instructions setting forth a method according to the present invention. Usually, the kits will further comprise a dilator and optionally still further comprise a guide dilator may be a simple dilator with no associated access sheath when the radially sleeve is plastically deformable or otherwise capable of maintaining its expanded diameter configuration. Alternatively, the dilator can be a conventional sheath/dilator combination when the radially expandable sleeve is elastic or compliant.

BRIEF DESCRIPTION OF THE DRAWINGS

[0020] FIG. 1 illustrates a system comprising a radially expandable sleeve, a dilator, and a guidewire, according to the present invention.

[0021] FIGS. 2A-2E illustrate use of the system of FIG. 1 for establishing vascular access to a target blood vessel according to a method of the present invention.

[0022] FIG. 3 illustrates a sleeve introducer which may be combined in an assembly with a radially expandable sleeve and optionally a guidewire according to the systems and methods of the present invention.

[0023] FIGS. 4A-4C illustrate use of the sleeve introducer assembly of FIG. 3 in the methods of the present invention.

[0024] FIG. 5 illustrates a system comprising a radially expandable sleeve, a needle and a dilator, according to the present invention.

[0025] FIG. 6A-6D illustrate use of the system of FIG. 5 for establishing vascular access to a target blood vessel, according to the present invention.

[0026] FIG. 7 illustrates a kit constructed in accordance with the principles of the present invention.

DESCRIPTION OF THE SPECIFIC EMBODIMENTS

[0027] Referring to FIG. 1, a system 10 for establishing vascular access according to the principles of the present invention comprises a radially expandable sleeve 12, a dilator 14, and a guidewire 16. The radially expandable sleeve comprises a radially expandable tubular body having a proximal end, a distal end, and an axial lumen extending from the proximal end to the distal end. Usually, a handle 20 is provided at the proximal end of the body so that the sleeve can be manually held during use, e.g., tension can be applied on the handle as the dilator 14 is passed through the body of the sleeve as described in more detail below. The radially expandable sleeve 12 may have a compliant or elastic structure which permits expansion from an initial small diameter (radially collapsed) configuration to a larger diameter configuration which is caused by introduction of the dilator therethrough. Use of the compliant or elastic sleeve will require a separate component for maintaining the expanded diameter of the tissue tract, as described in more detail below. Alternatively, the radially expandable sleeve can have a plastic or other locking structure so that, once expanded, it will retain its large diameter configuration without the need for using other supports, devices, or the like.

[0028] An exemplary radially expandable sleeve comprises an expandable tubular braid which is initially an elongated, narrow-diameter configuration. The braid may be open, but will usually be laminated or covered with a coating or layer of elastic or plastically deformable material, such as silicone rubber, latex, polyethylene, urethane, C-flex, or the like. The braid is preferably formed as a mesh of individual non-elastic filaments, such as polyamide fibers, polyester, stainless steel, or the like. The specific structures for forming such radially expandable sleeves are described in U.S. Pat. No. 5,814,058, a full disclosure of which has previously been incorporated herein by reference.

[0029] Exemplary sleeve diameters have been set forth above. Usually, the sleeve will have a length in the range from 3 cm to 30 cm, more usually from 10 cm to 25 cm. The exact dimensions of the sleeve will depend on the desired use and location of the target blood vessel to be accessed.

[0030] A dilator 14 may be a simple dilator having a tapered distal end and smooth transition to a uniform body diameter. The dilator will have a guidewire lumen to permit introduction over the guidewire and through the radially expandable sleeve, as described in more detail below. As illustrated, dilator 14 is in the form of a conventional sheath/dilator assembly of the type which is commercially available from vendors, such as Bard Cardiology, Billerica, Mass., under the trade

name Input™. The dilator/sheath assembly includes an outer sheath 30 with an inner tapered dilator 32 which is removable from the sheath. The sheath has a hemostatic valve 36 at its distal end and a side access tube 37 which permits perfusion or aspiration through the lumen of the sheath. The dilator 32 has a handle 38 at its proximal end and an internal lumen which permits introduction over the guidewire 16. The guidewire 16 may be a conventional vascular access guidewire, typically having a diameter of either 0.36 mm (0.014 in.) or 0.89 mm (0.035 in.), and a length in the range from 3.5 cm to 100 cm.

[0031] Referring now to FIGS. 2A-2E, use of the system 10 for accessing a blood vessel BV will be described. First, an initial tissue tract is formed using a needle N and syringe S assembly as shown in FIG. 2A. After access of the needle into the blood vessel BV is confirmed, typically by noting the flow of blood into the syringe S, the syringe may be removed and a guidewire GW placed through the needle into the blood vessel BV. The needle N may then be withdrawn over the proximal end of the guidewire GW, leaving the guidewire in place through a tissue tract TT, as illustrated in FIG. 2B. The radially expandable sleeve 12 is then introduced over the guidewire GW so that its distal end 13 lies within the blood vessel BV, as shown in FIG. 2C. The dilator 14 is then introduced over the guidewire GW so that the distal end of the dilator 14 causes radial expansion of the sleeve 12, as shown in FIG. 2D. After the dilator has been fully inserted through the sleeve 12 an inner dilator portion 32 may be withdrawn from the sheath 30, leaving the sheath in place through the radially expandable sleeve 12, both being over the guidewire GW, as shown in FIG. 2E. Vascular access has now been established for performing any one of a wide variety of diagnostic or therapeutic procedures as well described in the medical and patent literature.

[0032] Referring now to FIG. 3, a sleeve introducer 50 may be combined with a radially expandable sleeve 52 and optionally a guidewire 54 to form an expansible sleeve assembly intended for introduction through difficult tissue tracts, i.e., tissue tracts which might otherwise require excessive pushing force to introduce a sleeve according to the methods of the present invention. The sleeve introducer 50 comprises a tapered distal end 60, typically a conical element having a smaller diameter at its distal end and a larger diameter at its proximal end. The introducer 50 further comprises a shaft 62 extending proximally from the tapered distal end 60. The shaft will be a small tube, and the distal end 60 and shaft 62 together define a lumen which may be introduced over the guidewire 54. The outer diameter of the shaft 62 is selected so that it fits within the inner diameter of radially expandable sleeve 52. Preferably, the proximal end of the tapered distal end 60 will have a diameter which is the same as the outer diameter of the distal end 66 of the radially expandable sleeve 52. In this way, the sleeve introducer 50 may be placed within the lumen of the radially expandable sleeve 52 to form an assembly having a tapered distal end which facilitates introduction over the guidewire 54.

[0033] Referring now to FIGS. 4A-4C use of the assembly of FIG. 3 for dilating the tissue tract to a blood vessel BV will be described. The guidewire 54 is first placed into the blood vessel BV, typically using a needle as described above in connection in FIG. 3A. Usually, the guidewire 54 used for more difficult introductions will have a slightly smaller diameter than would otherwise be necessary, such as a diameter of about 0.6 mm (0.025 in.). The assembly of the sleeve intro-

ducer **50** and radially expandable sleeve **52** is then introduced over the guidewire, with the guidewire passing directly through the lumen of the introducer **50**. The tapered distal end **60** of the introducer **50** thus leads the way through the tissue over the guidewire **54**, so that the taper facilitates passage of the assembly through the tissue. After the assembly is in place, as shown in FIG. **4B**, a dilator **30** having an inner portion **32** may be introduced directly over the exterior of the sleeve introducer **50**, as shown in FIG. **4C**. After the tissue tract has been completely dilated, the combination of the sleeve introducer **50** and guidewire **54** may be withdrawn, leaving the inner diameter of the inner dilator portion **32** available for expanded access to the blood vessel BV.

[0034] Alternatively, as shown in FIG. **5**, a system **110** for establishing vascular access according to the principles of the present invention comprises a needle N, a radially expandable sleeve **112**, and a dilator **114**. The dilator **114** may be similar or identical to the dilator **14** previously described. However, in this case the dilator need not have a guidewire lumen. As previously illustrated, dilator **114** may be in the form of a conventional sheath/dilator assembly of the type which is commercially available from vendors, such as Bard Cardiology, Billerica, Mass., under the trade name Input™. The dilator/sheath assembly includes an outer sheath **130** with an inner tapered dilator **132** which is removable from the sheath. The sheath has a hemostatic valve **136** at its distal end and a side access tube **137** which permits perfusion or aspiration through the lumen of the sheath. The dilator **132** has a handle **138** at its proximal end. The dilator **114** shown in FIG. **5** is a conventional dilator, having a tapered distal end and a generally cylindrical body proximal to the distal end, without an associated access sheath. Such a dilator is suitable for use with or without an associated sheath.

[0035] The radially expandable sleeve **112** may be similar or identical to the sleeve **12** previously described and comprises a radially expandable tubular body having a proximal end, a distal end, and an axial lumen extending from the proximal end to the distal end. The expandable sleeve **112** may have a compliant or elastic structure which permits expansion from an initial small diameter (radially collapsed) configuration to a larger diameter configuration which is caused by introduction of the dilator **114** therethrough. Use of the compliant or elastic sleeve may require a separate component for maintaining the expanded diameter of the tissue tract. Such a component may be an access sheath associated with the dilator. In this case, the sleeve may contain a seal to prevent blood loss when the sheath is in place. As previously mentioned, the sheath itself may contain a hemostasis valve **136** preventing pressurized flow of blood within the blood vessel to escape through the sheath.

[0036] Alternatively, the radially expandable sleeve can have a plastic or other locking structure so that, once expanded, it will retain its large diameter configuration without the need for using other supports, devices, or the like, such as an access sheath. In this case, the sleeve itself would include a hemostasis valve within its axial lumen. Such a valve will maintain a closed position when the dilator or other devices are removed from the sleeve, thus preventing the pressurized flow of blood within the blood vessel to escape through the sleeve. The valve will maintain an open position when activated, such as by the insertion of a catheter or other device through the valve. For example, a duckbill or miter valve would be particularly suitable.

[0037] Referring now to FIGS. **6A-6C**, use of the system **110** for access vessel BV will be described. First, an initial tissue tract is formed using the expandable sleeve **112** mounted on an assembly comprising the needle N and a syringe S, as shown in FIG. **6A**. After access of the needle into the blood vessel BV is confirmed, typically by noting the flow of blood into the syringe S, the needle/syringe assembly is withdrawn leaving the sleeve **112** in place though a tissue tract TT to the blood vessel BV, as illustrated in FIG. **6B**. The sheath **130** dilator **132** assembly is then introduced through the sleeve **112** causing radial expansion of the sleeve **112**, as shown in FIG. **6C**. After the assembly has been fully inserted through the sleeve **112**, the inner dilator portion **132** may be withdrawn from the sheath **130**, leaving the sheath in place through the radially expandable sleeve **112**, as shown in FIG. **6D**. Vascular access has now been established for performing any one of a wide variety of diagnostic or therapeutic procedures as well described in the medical and patent literature.

[0038] Referring now to FIG. **7**, kits according to the present invention will comprise at least a radially expandable sleeve **12** or **112** together with instructions for use IFU setting forth any of the methods according to the principles of the present invention. Usually, a dilator **14** or **114** will also be included in the kit. The dilator **14** or **114** is shown as a simple dilator without an associated access sheath. Such a dilator is suitable for use with or without a sheath. The kits may optionally further comprise a guidewire GW, a sheath, a sleeve introducer **50**, and/or a needle N and all kit components will typically be packaged in a box, tray, tube, pouch, or other conventional medical device package P. The kit components which are employed in the medical procedure will typically be maintained within sterile packaging, with individual components being packaged either together or separately in different sterile containers. Usually, even when packaged in separate sterile containers, all components of the kit will be placed together within a common package. The instructions for use may be provided on a separate printed sheet, such as a conventional package insert, or may be printed in whole or in part on other portions of the packaging or the device itself.

[0039] While the above is a complete description of the preferred embodiments of the invention, various alternatives, modifications, and equivalents may be used. Therefore, the above description should not be taken as limiting the scope of the invention which is defined by the appended claims.

What is claimed is:

1. A method for establishing vascular access comprising the steps of:
 - introducing a distal end of a guidewire into a target vessel;
 - introducing a radially expandable sleeve over the guidewire such that a distal end of the sleeve lies within the target vessel; and
 - introducing a dilator over a proximal end of the guidewire and into a proximal end of the sleeve, and advancing the dilator distally along the guidewire and into the sleeve to effectuate radial expansion of the sleeve.
2. The method of claim **1**, further comprising the step of providing a dilator including an outer sheath at least partially surrounding a removable inner member, and removing the inner member of the introduced dilator, whereby the outer sheath of the dilator is left in place within the sleeve.
3. The method of claim **1**, further comprising the step of providing a dilator defining a longitudinal lumen there-through having an internal dimension between approximately 0.46 mm and approximately 1.0 mm.

4. The method of claim 3, wherein the step of providing a dilator includes providing a dilator having an outer dimension between approximately 1.0 mm and approximately 3.3 mm.

5. The method of claim 4, wherein the step of providing a dilator includes providing a dilator having an outer dimension between approximately 1.3 mm and approximately 2.5 mm.

6. The method of claim 1, further comprising the step of providing a radially expandable sleeve including a tubular braid formed of a mesh of non-elastic filaments which shorten axially as they are expanded radially.

7. A method for establishing access to a vascular lumen, the method comprising the steps of:

positioning a guidewire through tissue such that a distal end thereof is disposed within the vascular lumen;

providing an access assembly including a sleeve introducer positioned within a radially expandable sleeve;

introducing the access assembly over the guidewire such that a distal end of the sleeve lies within a target vessel; and

introducing a dilator over the sleeve introducer such that the dilator is disposed between the sleeve introducer and the radially expandable sleeve, wherein the dilator has a diameter that is larger than an initial diameter of the radially expandable sleeve, whereby the dilator radially enlarges a tissue tract formed in the tissue and facilitates access to the vascular lumen.

8. The method of claim 7, further including the step of removing the sleeve introducer and the guidewire from the vascular lumen, thereby leaving the dilator in place within the sleeve.

9. The method of claim 7, wherein the step of positioning a sleeve introducer within a radially expandable sleeve includes positioning a sleeve introducer having a tapered distal member with a shaft extending proximally therefrom within the radially expandable sleeve, the distal member being configured and dimensioned to facilitate passage of the access assembly through a tissue tract formed in the tissue to the vascular lumen.

10. The method of claim 9, wherein the step of positioning a sleeve introducer within a radially expandable sleeve includes positioning a sleeve introducer including a shaft defining a lumen therethrough that is configured to receive the guidewire.

11. The method of claim 10, wherein the step of positioning a sleeve introducer within a radially expandable sleeve includes positioning a sleeve introducer in which the tapered distal member of the sleeve introducer has a proximal end defining a radial dimension substantially equal to an outer radial dimension defined by the distal end of the radially expandable sleeve.

12. The method of claim 9, wherein the step of introducing a dilator includes introducing a dilator defining a longitudinal lumen therethrough configured to receive the shaft of the sleeve introducer.

13. The method of claim 12, wherein the step of introducing a dilator includes introducing a dilator defining a longi-

tudinal lumen therethrough with an internal dimension between approximately 0.46 mm and approximately 1.0 mm.

14. The method of claim 12, wherein the step of introducing a dilator includes introducing a dilator having an outer radial dimension along its entire length that is larger than an inner radial dimension of the sleeve such that insertion of the dilator into the sleeve effectuates radial expansion of the sleeve.

15. The method of claim 14, wherein the step of positioning a sleeve introducer within a radially expandable sleeve includes positioning a sleeve introducer within a radially expandable sleeve having a tubular braid formed of a mesh of non-elastic filaments which shorten axially as they are expanded radially.

16. The method of claim 14, wherein the step of introducing a dilator includes introducing a dilator having an outer dimension between approximately 1.0 mm and approximately 3.3 mm.

17. An improved method of establishing percutaneous access to a target vessel over a guidewire positioned within a tissue tract and having a distal end positioned within the target vessel, wherein the improved method comprises the steps of:

positioning a sleeve introducer within a radially expandable sleeve to form an access assembly;

introducing and advancing the access assembly over the guidewire such that a distal end of the radially expandable sleeve lies within the target vessel; and

introducing a dilator over the sleeve introducer and into the radially expandable sleeve to thereby enlarge the tissue tract and facilitate expanded access to the target vessel.

18. The improved method of claim 17, wherein the step of positioning a sleeve introducer within a radially expandable sleeve includes positioning a sleeve introducer having a tapered distal member with a shaft extending proximally therefrom, the tapered distal member being configured and dimensioned to facilitate passage of the access assembly through the tissue tract to the target vessel.

19. The improved method of claim 18, wherein the step of positioning a sleeve introducer within a radially expandable sleeve includes positioning a sleeve introducer wherein the shaft defines a lumen therethrough that is configured to receive the guidewire.

20. The method of claim 19, wherein the step of positioning a sleeve introducer within a radially expandable sleeve includes positioning a sleeve introducer wherein the distal member of the sleeve introducer has a proximal end defining a radial dimension substantially equal to an outer radial dimension defined by the distal end of the sleeve, wherein the distal member tapers distally from the proximal end thereof.

* * * * *