

(19)



(11)

**EP 3 637 023 B1**

(12)

**EUROPEAN PATENT SPECIFICATION**

(45) Date of publication and mention of the grant of the patent:

**12.07.2023 Bulletin 2023/28**

(51) International Patent Classification (IPC):

**F25B 39/04<sup>(2006.01)</sup> F28D 1/00<sup>(2006.01)</sup>**

(21) Application number: **18461616.7**

(52) Cooperative Patent Classification (CPC):

**F25B 39/04; F25B 43/003; F28F 19/01; F25B 2339/0441**

(22) Date of filing: **09.10.2018**

**(54) HEAT EXCHANGER WITH FILTER, FOR REFRIGERANT FLUID LOOP**

**WÄRMETAUSCHER MIT FILTER FÜR KÜHLMITTELFLÜSSIGKEITSKREISLAUF**

**ÉCHANGEUR DE CHALEUR AVEC FILTRE, POUR BOUCLE DE FLUIDE RÉFRIGÉRANT**

(84) Designated Contracting States:

**AL AT BE BG CH CY CZ DE DK EE ES FI FR GB GR HR HU IE IS IT LI LT LU LV MC MK MT NL NO PL PT RO RS SE SI SK SM TR**

- **SZOSTEK, Dawid**  
**32-050 Skawina (PL)**
- **CICHOSZ, Filip**  
**32-050 Skawina (PL)**

(43) Date of publication of application:

**15.04.2020 Bulletin 2020/16**

(74) Representative: **Valeo Systèmes Thermiques**

**Service Propriété Intellectuelle  
ZA l'Agot, 8 rue Louis Lormand  
CS 80517  
La Verrière  
78322 Le Mesnil-Saint-Denis Cedex (FR)**

(73) Proprietor: **Valeo Autosystemy SP. Z.O.O.**

**32-050 Skawina (PL)**

(72) Inventors:

- **BELZOWSKI, Michal**  
**32-050 Skawina (PL)**
- **POKRYWINSKI, Karol**  
**32-050 Skawina (PL)**

(56) References cited:

**EP-A1- 2 667 130 CA-A1- 2 013 377  
JP-A- H06 129 733 US-A- 3 881 546**

**EP 3 637 023 B1**

Note: Within nine months of the publication of the mention of the grant of the European patent in the European Patent Bulletin, any person may give notice to the European Patent Office of opposition to that patent, in accordance with the Implementing Regulations. Notice of opposition shall not be deemed to have been filed until the opposition fee has been paid. (Art. 99(1) European Patent Convention).

## Description

**[0001]** The present invention concerns the domain of heat exchangers designed for refrigerant fluid loops. More specifically, the present invention relates to devices for filtering the refrigerant fluid that flows through such heat exchangers.

**[0002]** A refrigerant fluid loop generally comprises at least two heat exchangers, at least one compressor and at least one expansion device. The compressor and the expansion device are both fragile and comprise movable elements that can easily break. It is therefore important that only the refrigerant fluid enters this compressor or the expansion device. In order to achieve that goal, it is already known to filter the refrigerant fluid before it reaches one of these components.

**[0003]** The document JPH06129733A discloses a heat exchanger according to the preamble of claim 1.

**[0004]** However, some particles may be inside heat exchangers, for instance due to manufacturing processes or default in the cleaning system of such heat exchanger. The cleaning of such particles appears to be really expensive and complex. And even with all the care that can be given to this cleaning, some of those particles, especially particles that have a diameter smaller than  $60\mu\text{m}$  can remain in those heat exchangers and can then be dragged by the refrigerant fluid to finally damage the compressor, the expansion device or any other element in which this refrigerant fluid could flow.

**[0005]** As a result, automotive suppliers are more and more concerned with this filtration, and they aim to filter even smaller particles than what is already filtered.

**[0006]** The present invention solves at least this issue, by providing a heat exchanger according to claim 1.

**[0007]** Such filter is located at the outlet where a pipe of the refrigerant fluid loop is attached to heat exchanger. According to the invention, the heat exchanger comprises an integrated receiver dryer, the filter is separated from any filtering means that could be located in the integrated receiver dryer, and is located downstream this integrated receiver dryer.

**[0008]** According to the invention, the filter is configured to filter particles presenting a certain diameter, for example above  $30\mu\text{m}$ , preferably above  $50\mu\text{m}$ , that can be dragged by the refrigerant fluid along its flow through the heat exchanger. As a result, those particles are prevented to reach any other element of the refrigerant fluid loop.

**[0009]** According to a feature of the invention, the heat exchanger comprises a block arranged at the outlet of the heat exchanger, the block comprising a path configured to allow a circulation of the refrigerant fluid inside the block, such path extending between the outlet of the heat exchanger and an orifice of the block, such orifice being configured to allow the refrigerant fluid to exit the block, wherein the block is provided with at least one opening configured to allow the insertion of the filter inside the block. For example, the block can be welded or

brazed to the heat exchanger, especially to the header tank. As a result, the path arranged inside the block directly extends the outlet of the heat exchanger in order to make sure that all the refrigerant fluid that exits the heat exchanger reaches the path of the block. Arranging the filter at the outlet of the heat exchanger allows a filtration of the particles that can remain in it, for instance due to manufacturing process, that are otherwise complex to clean. As the filter is pushed into the block through the opening, it can easily be removed and changed or cleaned, when needed.

**[0010]** According to the invention, the block comprises a cap configured to close the opening. According to a feature of the invention, the cap comprises a first portion configured to secure the cap to the block and a second portion configured to close the opening through which the filter is inserted in the block. In other words, the shape and the dimensions of the second part are similar, or substantially similar, to the shape and the dimensions of the opening. For example, the first portion of the cap can be screwed to the block.

**[0011]** According to the invention, the filter extends, at least partially, in the path arranged in the block. This filter is arranged in such a way that the refrigerant fluid enters the filter flowing along a first direction and exits the filter along a second direction, the first direction intersecting the second direction. Optionally, the first direction and the second direction are perpendicular.

**[0012]** The path comprises at least a first part, a second part substantially parallel to the first part, and a third part connecting the first part with the second part, the third part intersecting the first part and the second part. According to a specific embodiment of the present invention, the third part extends perpendicularly to the first part and the second part. Additionally, the path can comprise a fourth part connected to the second part, this fourth part intersecting the second part. Alternatively, the fourth part can extend perpendicularly to the second part. In other words, the second part, the third part and the fourth part form a U-shape wherein the base is formed by the third part and wherein the branches are respectively formed by the second and the fourth parts.

**[0013]** According to a first embodiment of the present invention, the filter is arranged at a junction between the second part and the third part. According to this first embodiment, the filter can extend mainly parallel to the second part. Alternatively, the filter can, according to this first embodiment, extend mainly parallel to the third part.

**[0014]** According to a second embodiment, the filter is arranged at a junction between the second part and the fourth part, and the filter extends mainly parallel to the fourth part.

**[0015]** Depending on the embodiment according to which the invention is realised, it is understood that the opening through which the filter is inserted in the block is arranged on different part of this block. In any case, this opening is arranged on order for the filter to be pushed into the path arranged in the block.

**[0016]** The filter comprises a frame in which at least one aperture is realized, the aperture being closed by a meshed element. For example, this meshed element can be made of synthetic material. Alternatively, the meshed element can be made of metal. Obviously, the size of this meshed element determines the size of the particles that are retained by the filter and according to the invention, this meshed element is configured to retain particles presenting a certain diameter, for example larger than 50 $\mu$ m. For example, the filter can have a cylindrical shape with a circular cross section.

**[0017]** According to the invention, the filter extends mainly along a longitudinal axis, the filter comprising a first end and a second end along this longitudinal axis, and the filter comprises a collar arranged at its first end, this collar being configured to seal the opening through which the filter can be inserted in the block. More precisely, this collar is arranged between the block and the cap, and especially between the block and the second portion of the cap. For example, the collar can be overmolded on the first end of the filter. As a result, it is to be understood that the filter is inserted in the path arranged in the block by its second end.

**[0018]** According to another feature of the present invention, a sealing device is arranged between the second end of the filter and a wall defining the path. More precisely, the sealing device is arranged between an outer periphery of the filter and the wall defining the path arranged in the block. In other words, this sealing device is designed to be in contact both with the wall defining the path and with the outer periphery of the filter. Advantageously, when the filter comprises both the collar and the sealing device, it is understood that all the refrigerant fluid that flows through the path of the block also flows through the filter. Consequently, thanks to the invention, all the refrigerant fluid that exit the heat exchanger is filtered by this filter and none of the small particles it could have dragged will reach the rest of the refrigerant fluid loop the heat exchanger is designed for, protecting the other elements of such refrigerant fluid loop.

**[0019]** For example, the sealing device can be an O-ring. Alternatively, the sealing device can comprise at least one tooth realized on an outer periphery of the frame of the filter. For instance, the at least one tooth and the outer periphery of this frame form a single piece, that is to say that the outer periphery of the frame and the at least one tooth cannot be separated without damaging one of them. According to a specific embodiment of the present invention, the sealing device comprises three teeth, all of those teeth extending all around the outer periphery of the frame of the filter and the wall defining the path.

**[0020]** According to an aspect of the invention, the block is made of a single piece. In other words, according to this aspect of the invention, the block forms a monobloc piece and the elements that are part of it cannot be separated without damaging at least one of them. Such a monobloc piece may be attached to the header tank of

the heat exchanger, for example by welding or brazing.

**[0021]** According to another aspect of the invention, a duct can be layered between the outlet and the block. To put it in another way, the connection between the block and the outlet of the heat exchanger can be indirect, allowing the block to be placed away from the heat exchanger, without reducing the efficiency of the filtration.

**[0022]** The present invention also concerns a refrigerant fluid loop comprising at least one compressor, a first heat exchanger, one expansion device, and a second heat exchanger, wherein at least the first heat exchanger is realized according to the present invention.

**[0023]** The present invention also relates to a motor vehicle comprising at least one refrigerant fluid loop comprising at least one heat exchanger according to the present invention. According to a specific application of the invention, the heat exchanger can be used as a condenser, that is to say that this heat exchanger is configured to allow the refrigerant fluid that flows through it to cool and, as a result, to liquefy.

**[0024]** Other features, details and advantages of the invention can be inferred from the specification of the invention given hereunder. Various embodiments are represented in the figures wherein:

- figure 1 is a schematic representation of a refrigerant fluid loop comprising at least one heat exchanger according to the invention;
- figure 2 is a perspective view of a block comprising a filter, the block being designed to be connected to the heat exchanger according to the invention ;
- figure 3 is a perspective view of the filter comprised in the block illustrated on figure 2 ;
- figure 4 is a cross-section view of the block illustrated on figure 2, the figure making visible the filter arranged into said block according to a first embodiment of the invention;
- figure 5 is a cross-section view of the block which comprises the filter, according to a variant of the first embodiment of the invention illustrated on figure 4 and wherein the filter is represented in a schematic manner ;
- figure 6 is a cross-section view of the block illustrated on figure 2, the figure making visible the filter arranged into said block according to a second embodiment of the invention, this filter being illustrated in a schematic manner.

**[0025]** Figure 1 is a schematic view of a refrigerant fluid loop 100 intended to be accommodated in a motor vehicle. This refrigerant fluid loop 100 comprises at least a compressor 110 configured to increase the pressure of a refrigerant fluid R circulating through the loop 100, a

first heat exchanger 120 configured to undertake a heat exchange between the refrigerant fluid R and a first airflow AF1, an expansion device 130 configured to decrease the pressure of the refrigerant fluid R and a second heat exchanger 140 configured to undertake a heat exchange between the refrigerant fluid R and a second airflow AF2. For instance, the first airflow AF1 is taken outside the motor vehicle in which the refrigerant fluid loop 100 is accommodated, and the second airflow AF2 is reserved to be sent in a passenger compartment of said motor vehicle.

**[0026]** According to the illustrated embodiment, the first heat exchanger 120 is realized according to the invention and comprises a block 200 in which, as explained in more details below, a filter 300 is arranged. According to the invention, this filter is located at an outlet 122 of the heat exchanger. As illustrated, the block 200 is arranged after the first heat exchanger 120 along a flowing direction of the refrigerant fluid R, this flowing direction being illustrated by the arrow R

**[0027]** First, the refrigerant fluid R exits the compressor 110 in a gaseous state and reaches the first heat exchanger 120, and more precisely it reaches an inlet 121 of the first heat exchanger 120. Once the refrigerant fluid R has entered the first heat exchanger 120, a transfer of calories is undertaken between said refrigerant fluid R circulating in this first heat exchanger 120 and the first airflow AF1 that flows through it. More precisely, the refrigerant fluid R gives calories to the first airflow AF1 and liquefies. In other words, the first heat exchanger 120 acts, in this particular example, as a condenser. As a result, the refrigerant fluid R exits the first heat exchanger 120 in a liquefied state and reaches the block 200 wherein it is filtered by the filter 300. In other words, it is to be understood that the block 200 is connected on one hand to an outlet 122 of the first heat exchanger 120 configured to allow the refrigerant fluid R to exit said first heat exchanger 120 and on the other hand to a pipe 101 of the refrigerant fluid loop 100. Then the refrigerant fluid R goes through the expansion device 130 in which its pressure is reduced before it reaches the second heat exchanger 140. In this second heat exchanger 140, the refrigerant fluid R takes calories from the second airflow AF2 and evaporates. The second airflow AF2 can then be sent to the passenger compartment to drop the temperature of this compartment and the refrigerant fluid R, which is again in a gaseous state, can again reach the compressor 110 to start a new cycle.

**[0028]** Generally speaking, the first heat exchanger 120 and the second heat exchanger 140 are similar and both comprise at least two manifolds or header tanks arranged at an extremity of a heat exchange area wherein the heat exchange between the refrigerant fluid and the first or the second airflow AF1, AF2 takes place.

**[0029]** We are now going to describe with more details the block 200 connected to the first heat exchanger 120. For the rest of the specification, the words "first heat exchanger" and "heat exchanger" will be used with no dis-

inction.

**[0030]** Figure 2 is a perspective view of the block 200 which houses the filter 300. As illustrated, this block 200 is made of a single piece, that is to say that the pieces that constitute it cannot be separated without damaging at least one of them. As mentioned earlier, this block 200 is connected to the first heat exchanger and this block 200 may be considered as the outlet of the heat exchanger. In order to achieve this connection, the block 200 presents a hollowness 210 configured to receive a projection of the first heat exchanger. At a centre of this hollowness 210 extends a conduit 211 that forms an inlet of the block 200, that is to say an orifice through which the refrigerant fluid can enter the block. As shown on figure 2, this conduit 211 presents a size that allows a physical contact between the block and the heat exchanger. As a result, this block 200 can for instance be welded or brazed to the heat exchanger. Advantageously, this connection prevents any refrigerant fluid leakage between the heat exchanger and the block 200. According to an embodiment which is not illustrated here, a duct can be layered between the block and the heat exchanger, this duct being at least long enough to avoid any physical contact between the heat exchanger and the block. In other words, according to this embodiment, the block is arranged away from the heat exchanger, but is in any way considered as the outlet of the heat exchanger, because this block is a one-component with the rest of the heat exchanger, and is the part that received the pipe connecting the heat exchanger to the refrigerant fluid loop.

**[0031]** As detailed hereafter, the block 200 also comprises a path that extends between the inlet of the block 200 and an orifice 221 of the block 200 - that can be seen on figures 4 to 6 - which allows the refrigerant fluid to exit the block 200.

**[0032]** As mentioned above, a filter is arranged in the block 200. As it will be detailed later, the filter extends, at least partially, in the path arranged in the block 200. According to the invention, the block 200 comprises at least one opening 220 - for instance illustrated on figures 4 to 6 - configured to allow the insertion of such a filter. In order to close this opening 220 a cap 230 is provided, this cap 230 being configured to protect the filter and to avoid any unsolicited material to enter the block 200. As illustrated, this cap 230 comprises a first portion 231 secured to the block 200 and a second portion 232 configured to close the opening 220, by entering this opening 220. According to the embodiment described here, the first portion 231 is secured to the block 200 thanks to a screw 233. The second portion 232 is more particularly provided with a recess 234 that fits the opening 220, that is to say that said recess 234 has a similar shape and similar dimensions with the opening, in order to help preventing refrigerant fluid leakages. In other words, it is understood that a bottom 235 that defines said recess 234 at least partially extends in the path 240 of the block 200.

**[0033]** Figure 3 is a perspective view of the filter 300

that is inserted through the at least one opening arranged in the block. As illustrated, this filter 300 extends mainly along a longitudinal axis X and comprises a first end 301 and a second end 302 along this longitudinal axis X.

**[0034]** This filter 300 comprises a frame 303 in which at least one aperture 304 is made, advantageously several apertures 304, those apertures 304 being closed with a meshed element 305. The size of this meshed element 305 determines the size of the particles that are filtered by this filter 300. According to the invention, this meshed element 305 is chosen for its ability to filter particles presenting a certain diameter, for example larger than 50 μm. This meshed element 305 can comprise a synthetic material or metal material. As illustrated, the filter 300 has a cylindrical shape and a circular cross section. More precisely, the frame 303 of this filter 300 has a cylindrical shape in which apertures 304 are created, each aperture 304 extending mainly parallel to the longitudinal axis X. Consequently, it is understood that the refrigerant fluid that reaches such filter 300 enters this filter 300 along a first direction d1 and exits this filter 300 along a second direction d2, the first direction d1 intersecting the second direction d2. According to the embodiment illustrated here, the first direction d1 is parallel to the longitudinal axis X and the second direction d2 is perpendicular to this longitudinal axis X. As detailed below, especially with reference to figures 5 and 6, according to a different embodiment of the invention, the first direction d1 can extend perpendicularly to the longitudinal axis X while the second direction d2 extends parallel to said longitudinal axis X. To put it another way, depending on the embodiment chosen, the refrigerant fluid can be filtered when it enters the filter 300 or when it exits it.

**[0035]** As illustrated, the filter 300 can also comprise a collar 310 which, as explained below, is configured to seal the opening through which the filter 300 is inserted in the block. According to the illustrated embodiment, this collar 310 is arranged at the first end 301 of the filter 300, and more particularly, this collar 310 can be overmolded with this first end 301. Therefore, this filter 300 is inserted in the block by its second end 302. As explained above, the invention aims to filter all the refrigerant fluid that exits the heat exchanger. Additionally, a sealing device 320 can therefore be arranged at the second end 302 of the filter 300. As shown on figures 3 to 6, this sealing device 320 is layered between the filter 300 and a wall defining the path in which the filter 300 is intended to be inserted. This sealing device 320 can be part of the filter 300, by being moulded out of the frame 303, as shown on figure 3 or 4. The sealing device 320 can also be a separated seal located between the frame 303 and the block 200, as illustrated by figures 5 or 6.

**[0036]** According to the embodiment illustrated on figure 3, the sealing device 320 comprises teeth 321, for example three teeth 321. Those teeth 321 emerge from an outer periphery of the frame 303 of the filter 300, said teeth 321 and said outer periphery forming a single piece, that is to say that the teeth 321 and the outer periphery

of the frame 303 cannot be separated without damaging at least one of them. As explained below, those teeth 321 are designed to prevent the refrigerant fluid to by-pass the filter 300, that is to say to make sure that all the refrigerant fluid that enters the block goes through the filter 300. Obviously, this embodiment is only an example of what can be the sealing device 320, and does not restrict the present invention. For instance, said sealing device 320 could comprise only one tooth or more than three teeth without getting out of the invention context. Alternatively, as shown on figures 5 and 6, this sealing device can be an O-ring arranged all around the second end 302 of the filter 300.

**[0037]** Referring now to figures 4 to 6, we're going to describe in more details the interior of the block 200, including the path 240 in which the filter 300 is intended to be inserted. Figures 4 and 5 both illustrate a first embodiment of the present invention according to two different variants and figure 6 illustrates a second embodiment of the present invention. Those embodiments differ essentially from one another in the position of the filter 300 within the path 240.

**[0038]** As mentioned above, the block 200 comprises the path 240 that is reached by the refrigerant fluid that exit the heat exchanger tank and in which the filter 300 is arranged. According to any of said embodiments, the path 240 is defined by a continuous wall of the block 200 and comprises at least a first part 241 parallel to a second part 242, this first part 241 and this second part 242 being connected to each other by a third part 243 that intersects both the first and the second parts 241, 242. As illustrated, the third part 243 more precisely extends perpendicularly to the first part 241 and the second part 242. According to the embodiments illustrated here, the path 240 also comprises a fourth part 244 that extends the second part 242 and that intersects said second part 242. According to the embodiments illustrated here, this fourth part 244 more precisely extends perpendicularly to the second part 242, that is to say that this fourth part 244 extends parallel to the third part 243. To faster understanding of the present invention, the continuous wall which defines the path 240 is arbitrarily divided into four segments, a first segment 341 that defines the first part 241 of the path 240, a second segment 342 that defines the second part 242 of the path 240, a third segment 343 that defines the third part 243 of the path 240 and a fourth segment 344 that defines the fourth part 244 of the path 240. The cross section of the path 240 as described above is circular.

**[0039]** As explained above, the path 240 extends between an exit of the header tank of the heat exchanger, which also forms the inlet of the block 200, and the orifice 221 of the block 200 which is configured to allow the refrigerant fluid to exit the block 200. More particularly, the first part 241 of the path 240 is arranged in the conduit 211 designed to be connected to the exit of the header tank of the heat exchanger. In other words, the first segment 341 of the wall defining the path 240 also defines

the conduit 211 thanks to which the block 200 is connected to the heat exchanger.

**[0040]** According to the first embodiment illustrated on figure 4, the opening 220 is drilled in the second segment 342 of the wall defining the path 240, and more specifically in a portion of said second segment 342 that faces the third part 243 of the path 240. As a result, the filter 300, which is inserted through this opening 220, extends at a junction between the second part 242 and the third part 243 of the path 240 and extends mainly parallel to said third part 243. In other words, the longitudinal axis X is parallel, according to this first embodiment, to the third part 243 of the path 240.

**[0041]** As illustrated, a groove 222 is realized all around the opening 220 through which the filter 300 is inserted, this groove 222 being configured to receive the collar 310 overmolded on the first end 301 of the filter 300. After the insertion of the filter 300, the cap is positioned and the bottom defining the recess realized in the first portion of said cap extends in the filter 300, while the rest of the first portion covers the collar 310 in order to avoid refrigerant fluid leakage.

**[0042]** At the second end 302 of the filter 300, the sealing device 320 which, according to this first embodiment, comprises three teeth 321, is in contact with the wall defining the path 240, and specifically with the third segment 343 of this wall, in order to make sure that all the refrigerant fluid that enters said path 240 goes through said filter 300. According to the illustrated embodiment, the first direction d1 along which the refrigerant fluid enters the filter 300 is parallel to the longitudinal axis X and the second direction d2 along which the refrigerant fluid exits the filter 300 is perpendicular to this longitudinal axis X. In other words, according to this first embodiment, the refrigerant fluid exits the filter 300 through the meshed element that closes the apertures 304 of it, that is to say that this refrigerant fluid is filtered when it exits said filter 300. Once in the second part 242 of the path 240, the refrigerant fluid reaches the fourth part 244 and then exits the block 200 thanks to the orifice 221 and then continues the refrigerant fluid loop on which the block 200 is positioned.

**[0043]** According to the variant of the first embodiment illustrated on figure 5, the block 200 differs from first embodiment illustrated on figure 4 essentially on the position of the opening 220. As illustrated, according to this variant, this opening 220 is realized in the third segment 343 of the wall that defines the third part 243 of the path 240 and specifically in a portion of this third segment 343 that faces the second part 242 of the path 240. As a result, the filter 300 inserted through said opening 220 still extends at the junction between the second and the third part 242, 243 but it extends mainly parallel to the second part 242. According to this variant, the refrigerant fluid enters by the apertures 304 closed by the meshed element 305. In other words, the first direction d1 is perpendicular to the longitudinal axis X and the second direction d2 is parallel to this longitudinal axis X and the refrigerant

fluid is filtered when it enters the filter 300.

**[0044]** The sealing device 320 also differs from the first embodiment illustrated on figure 4 and comprises an O-ring 322 arranged between the frame 303 of the filter 300 and the second segment 342 of the wall defining the path 240 and more particularly, this O-ring 322 is compressed between this second segment 342 of the wall and the frame 303 of the filter 300, in order to make sure that all the refrigerant fluid that enters the block 200 also goes through the filter 300 and that all the particles presenting a certain diameter, for example above 30 $\mu$ m, preferably above 50 $\mu$ m, are eliminated from this refrigerant fluid.

**[0045]** Figure 6 finally illustrates a second embodiment of the present invention that differs from the first embodiment in the fact that the filter 300 is arranged at a junction between the second part 242 and the fourth part 244 and that it extends mainly parallel to said fourth part 244. To achieve this second embodiment, the opening 220, through which the filter 300 is inserted, is realized in a portion of the second segment 342 of the wall defining the path 240 that faces the fourth part 244 of the path 240. In a similar way to what has been described related to figure 5, the refrigerant fluid, according to this second embodiment, is filtered when it enters the filter 300. In other words, the refrigerant fluid enters said filter 300 through the apertures 304 when crossing the meshed element 305, that is to say that the first direction d1 extends perpendicularly to the longitudinal axis X and exits the filter 300 through its second end 302, that is to say that the second direction d2 extends parallel to the longitudinal axis X.

**[0046]** According to this second embodiment, the sealing device 320 is an O-ring as detailed above with reference to figure 5. Alternatively, it is understood that this sealing device 320 could be different, for instance, it could comprise teeth realised on the outer periphery of the frame 303 of the filter 300, as explained with reference to figure 4.

**[0047]** It will be understood from the foregoing that the present invention provides a simple, easily adaptable and easily replaceable means to filter the refrigerant fluid that exit a heat exchanger accommodated on a refrigerant fluid loop so as to prevent any damage on other components of such a refrigerant fluid loop.

**[0048]** However, the invention cannot be limited to the means and configurations described and illustrated herein, and it also extends to any equivalent means or configurations and to any technically operative combination of such means. In particular, the shape and arrangement of the block and/or the filter can be modified insofar as they fulfil the functionalities described in the present document.

## 55 Claims

1. Heat exchanger (120) for a refrigerant fluid loop (100), the heat exchanger (120) comprising at least

one inlet (121) configured to allow a refrigerant fluid (R) to enter in the heat exchanger (120), at least one outlet (122) configured to allow the refrigerant fluid (R) to exit the heat exchanger (120), and an integrated receiver drier comprising filtering means located therein, the heat exchanger (120) comprising a filter (300) configured to filter the refrigerant fluid (R), **characterized in that** the filter (300) is arranged at the outlet (122) of the heat exchanger (120), wherein the filter (300) is separated from any filtering means located in the integrated receiver drier.

2. Heat exchanger (120) according to the preceding claim, comprising a block (200) arranged at the outlet (122) of the heat exchanger (120), the block (200) comprising a path (240) configured to allow a circulation of the refrigerant fluid (R) inside the block (200), said path (240) extending between the outlet (122) of the heat exchanger (120) and an orifice (221) of the block (200), said orifice (221) being configured to allow the refrigerant fluid (R) to exit the block (200), wherein the block (200) is provided with at least one opening (220) configured to allow the insertion of the filter (300) inside the block (200).
3. Heat exchanger (120) according to the preceding claim, wherein the block (200) comprises a cap (230) configured to close the opening (220).
4. Heat exchanger (120) according to the preceding claim, wherein the cap (230) comprises a first portion (231) configured to secure the cap (230) to the block (200) and a second portion (232) configured to close the opening (220) through which the filter (300) is inserted in the block (200).
5. Heat exchanger (120) according to any of claims 2 to 4, wherein the filter (300) extends, at least partially, in the path (240) arranged in the block (200).
6. Heat exchanger (120) according to any of claims 2 to 5, wherein the filter (300) is arranged in such a way that the refrigerant fluid (R) enters the filter (300) flowing along a first direction (d1) and exits the filter (300) along a second direction (d2), the first direction (d1) intersecting the second direction (d2).
7. Heat exchanger (120) according to any of claims 2 to 6, wherein the path (240) comprises at least a first part (241), a second part (242) substantially parallel to the first part (241), and a third part (243) connecting the first part (241) to the second part (242), the third part (243) intersecting the first part (241) and the second part (242).
8. Heat exchanger (120) according to the preceding claim, wherein the path (240) comprises a fourth part (244) connecting the second part (242), this fourth

part (244) intersecting the second part (242).

9. Heat exchanger (120) according to any of claims 2 to 8, wherein the filter (300) comprises a frame (303) in which at least one aperture (304) is realized, the aperture (304) being closed by a meshed element.
10. Heat exchanger (120) according to any of claims 2 to 9, wherein the filter (300) extends mainly along a longitudinal axis (X), the filter (300) comprising a first end (301) and a second end (302) along this longitudinal axis (X), and wherein the filter (300) comprises a collar (310) arranged at its first end (301), this collar (310) being configured to seal the opening (220) through which the filter (300) can be inserted in the block (200).
11. Heat exchanger (120) according to the preceding claim, wherein the collar (310) is arranged between the block (200) and the cap (230).
12. Heat exchanger (120) according to any of claims 10 to 11, comprising a sealing device (320) arranged between the second end (302) of the filter (300) and a wall (341, 342, 343, 344) defining the path (240).
13. Heat exchanger (120) according to any of claims 2 to 12, wherein the block (200) is made of a single piece.
14. Heat exchanger (120) according to any of the claims 2 to 13, wherein a duct is layered between the outlet (122) and the block (200).

#### Patentansprüche

1. Wärmetauscher (120) für einen Kältemittelfluidkreis (100), wobei der Wärmetauscher (120) mindestens einen Einlass (121), der dazu ausgelegt ist, einem Kältemittelfluid (R) zu ermöglichen, in den Wärmetauscher (120) einzutreten, mindestens einen Auslass (122), der dazu ausgelegt ist, dem Kältemittelfluid (R) zu ermöglichen, aus dem Wärmetauscher (120) auszutreten, und einen integrierten Sammlertrockner umfasst, der darin angeordnete Filterungsmittel umfasst, wobei der Wärmetauscher (120) einen Filter (300) umfasst, der dazu ausgelegt ist, das Kältemittelfluid (R) zu filtern, **dadurch gekennzeichnet, dass** der Filter (300) an dem Auslass (122) des Wärmetauschers (120) angeordnet ist, wobei der Filter (300) von jedem in dem integrierten Sammlertrockner angeordneten Filterungsmittel getrennt ist.
2. Wärmetauscher (120) nach dem vorausgehenden Anspruch, umfassend einen Block (200), der an dem Auslass (122) des Wärmetauschers (120) angeord-

- net ist, wobei der Block (200) einen Pfad (240) umfasst, der dazu ausgelegt ist, eine Zirkulation des Kältemittelfluids (R) in dem Block (200) zu ermöglichen, wobei sich der Pfad (240) zwischen dem Auslass (122) des Wärmetauschers (120) und einem Durchlass (221) des Blocks (200) erstreckt, wobei der Durchlass (221) dazu ausgelegt ist, dem Kältemittelfluid (R) zu ermöglichen, aus dem Block (200) auszutreten, wobei der Block (200) mit mindestens einer Öffnung (220) versehen ist, die dazu ausgelegt ist, das Einsetzen des Filters (300) in den Block (200) zu ermöglichen.
3. Wärmetauscher (120) nach dem vorausgehenden Anspruch, wobei der Block (200) einen Deckel (230) umfasst, der dazu ausgelegt ist, die Öffnung (220) zu verschließen.
  4. Wärmetauscher (120) nach dem vorausgehenden Anspruch, wobei der Deckel (230) einen ersten Abschnitt (231), der dazu ausgelegt ist, den Deckel (230) an dem Block (200) zu befestigen, und einen zweiten Abschnitt (232), der dazu ausgelegt ist, die Öffnung (220), durch die der Filter (300) in den Block (200) eingesetzt wird, zu verschließen, umfasst.
  5. Wärmetauscher (120) nach einem der Ansprüche 2 bis 4, wobei der Filter (300) sich zumindest teilweise in den in dem Block (200) angeordneten Pfad (240) erstreckt.
  6. Wärmetauscher (120) nach einem der Ansprüche 2 bis 5, wobei der Filter (300) derart angeordnet ist, dass das Kältemittelfluid (R) entlang einer ersten Richtung (d1) strömend in den Filter (300) eintritt und entlang einer zweiten Richtung (d2) aus dem Filter (300) austritt, wobei die erste Richtung (d1) die zweite Richtung (d2) schneidet.
  7. Wärmetauscher (120) nach einem der Ansprüche 2 bis 6, wobei der Pfad (240) mindestens einen ersten Teil (241), einen zweiten Teil (242), der im Wesentlichen parallel zu dem ersten Teil (241) ist, und einen dritten Teil (243), der den ersten Teil (241) mit dem zweiten Teil (242) verbindet, umfasst, wobei der dritte Teil (243) den ersten Teil (241) und den zweiten Teil (242) schneidet.
  8. Wärmetauscher (120) nach dem vorausgehenden Anspruch, wobei der Pfad (240) einen vierten Teil (244) umfasst, der den zweiten Teil (242) verbindet, wobei der vierte Teil (244) den zweiten Teil (242) schneidet.
  9. Wärmetauscher (120) nach einem der Ansprüche 2 bis 8, wobei der Filter (300) einen Rahmen (303) umfasst, in dem mindestens ein Ausschnitt (304) ausgeführt ist, wobei der Ausschnitt (304) durch ein Maschenelement verschlossen ist.
  10. Wärmetauscher (120) nach einem der Ansprüche 2 bis 9, wobei sich der Filter (300) hauptsächlich entlang einer Längsachse (X) erstreckt, wobei der Filter (300) ein erstes Ende (301) und ein zweites Ende (302) entlang der Längsachse (X) umfasst, und wobei der Filter (300) eine an seinem ersten Ende (301) angeordnete Manschette (310) umfasst, wobei die Manschette (310) dazu ausgelegt ist, die Öffnung (220), durch die der Filter (300) in den Block (200) eingesetzt werden kann, abzudichten.
  11. Wärmetauscher (120) nach dem vorausgehenden Anspruch, wobei die Manschette (310) zwischen dem Block (200) und dem Deckel (230) angeordnet ist.
  12. Wärmetauscher (120) nach einem der Ansprüche 10 bis 11, umfassend eine Dichtungsvorrichtung (320), die zwischen dem zweiten Ende (302) des Filters (300) und einer Wand (341, 342, 343, 344), die den Pfad (240) definiert, angeordnet ist.
  13. Wärmetauscher (120) nach einem der Ansprüche 2 bis 12, wobei der Block (200) aus einem einzigen Stück besteht.
  14. Wärmetauscher (120) nach einem der Ansprüche 2 bis 13, wobei ein Kanal zwischen dem Auslass (122) und dem Block (200) geschichtet ist.

#### Revendications

1. Échangeur de chaleur (120) pour une boucle de fluide réfrigérant (100), l'échangeur de chaleur (120) comprenant au moins une entrée (121) conçue pour permettre à un fluide réfrigérant (R) d'entrer dans l'échangeur de chaleur (120), au moins une sortie (122) conçue pour permettre au fluide réfrigérant (R) de sortir de l'échangeur de chaleur (120), et un sécheur récepteur intégré comprenant des moyens de filtrage situés en son sein, l'échangeur de chaleur (120) comprenant un filtre (300) conçu pour filtrer le fluide réfrigérant (R), **caractérisé en ce que** le filtre (300) est disposé à la sortie (122) de l'échangeur de chaleur (120), dans lequel le filtre (300) est séparé de tout moyen de filtrage situé dans le sécheur récepteur intégré.
2. Échangeur de chaleur (120) selon la revendication précédente, comprenant un bloc (200) disposé à la sortie (122) de l'échangeur de chaleur (120), le bloc (200) comprenant un chemin (240) conçu pour permettre une circulation du fluide réfrigérant (R) à l'intérieur du bloc (200), ledit chemin (240) s'étendant entre la sortie (122) de l'échangeur de chaleur (120)

- et un orifice (221) du bloc (200), ledit orifice (221) étant conçu pour permettre au fluide réfrigérant (R) de sortir du bloc (200), dans lequel le bloc (200) est muni d'au moins une ouverture (220) conçue pour permettre l'insertion du filtre (300) à l'intérieur du bloc (200).
- 5
3. Échangeur de chaleur (120) selon la revendication précédente, dans lequel le bloc (200) comprend un bouchon (230) conçu pour fermer l'ouverture (220).
- 10
4. Échangeur de chaleur (120) selon la revendication précédente, dans lequel le bouchon (230) comprend une première partie (231) conçue pour fixer le bouchon (230) sur le bloc (200) et une seconde partie (232) conçue pour fermer l'ouverture (220) par laquelle le filtre (300) est inséré dans le bloc (200).
- 15
5. Échangeur de chaleur (120) selon l'une quelconque des revendications 2 à 4, dans lequel le filtre (300) s'étend au moins partiellement dans le chemin (240) disposé dans le bloc (200).
- 20
6. Échangeur de chaleur (120) selon l'une quelconque des revendications 2 à 5, dans lequel le filtre (300) est disposé de telle sorte que le fluide réfrigérant (R) entre dans le filtre (300) en circulant le long d'une première direction (d1) et sort du filtre (300) le long d'une seconde direction (d2), la première direction (d1) croisant la seconde direction (d2).
- 25
7. Échangeur de chaleur (120) selon l'une quelconque des revendications 2 à 6, dans lequel le chemin (240) comprend au moins une première partie (241), une deuxième partie (242) sensiblement parallèle à la première partie (241), et une troisième partie (243) reliant la première partie (241) à la deuxième partie (242), la troisième partie (243) croisant la première partie (241) et la deuxième partie (242).
- 30
- 35
- 40
8. Échangeur de chaleur (120) selon la revendication précédente, dans lequel le chemin (240) comprend une quatrième partie (244) reliant la deuxième partie (242), ladite quatrième partie (244) croisant la deuxième partie (242).
- 45
9. Échangeur de chaleur (120) selon l'une quelconque des revendications 2 à 8, dans lequel le filtre (300) comprend une structure (303) dans laquelle au moins une ouverture (304) est réalisée, l'ouverture (304) étant fermée par un élément maillé.
- 50
10. Échangeur de chaleur (120) selon l'une quelconque des revendications 2 à 9, dans lequel le filtre (300) s'étend principalement le long d'un axe longitudinal (X), le filtre (300) comprenant une première extrémité (301) et une seconde extrémité (302) le long dudit axe longitudinal (X), et dans lequel le filtre (300) com-
- 55
- prend un collier (310) disposé à sa première extrémité (301), ledit collier (310) étant conçu pour sceller l'ouverture (220) par laquelle le filtre (300) peut être inséré dans le bloc (200).
11. Échangeur de chaleur (120) selon la revendication précédente, dans lequel le collier (310) est disposé entre le bloc (200) et le bouchon (230).
12. Échangeur de chaleur (120) selon l'une quelconque des revendications 10 à 11, comprenant un dispositif d'étanchéité (320) disposé entre la seconde extrémité (302) du filtre (300) et une paroi (341, 342, 343, 344) définissant le chemin (240).
13. Échangeur de chaleur (120) selon l'une quelconque des revendications 2 à 12, dans lequel le bloc (200) est constitué d'une seule pièce.
14. Échangeur de chaleur (120) selon l'une quelconque des revendications 2 à 13, dans lequel un conduit est disposé entre la sortie (122) et le bloc (200).

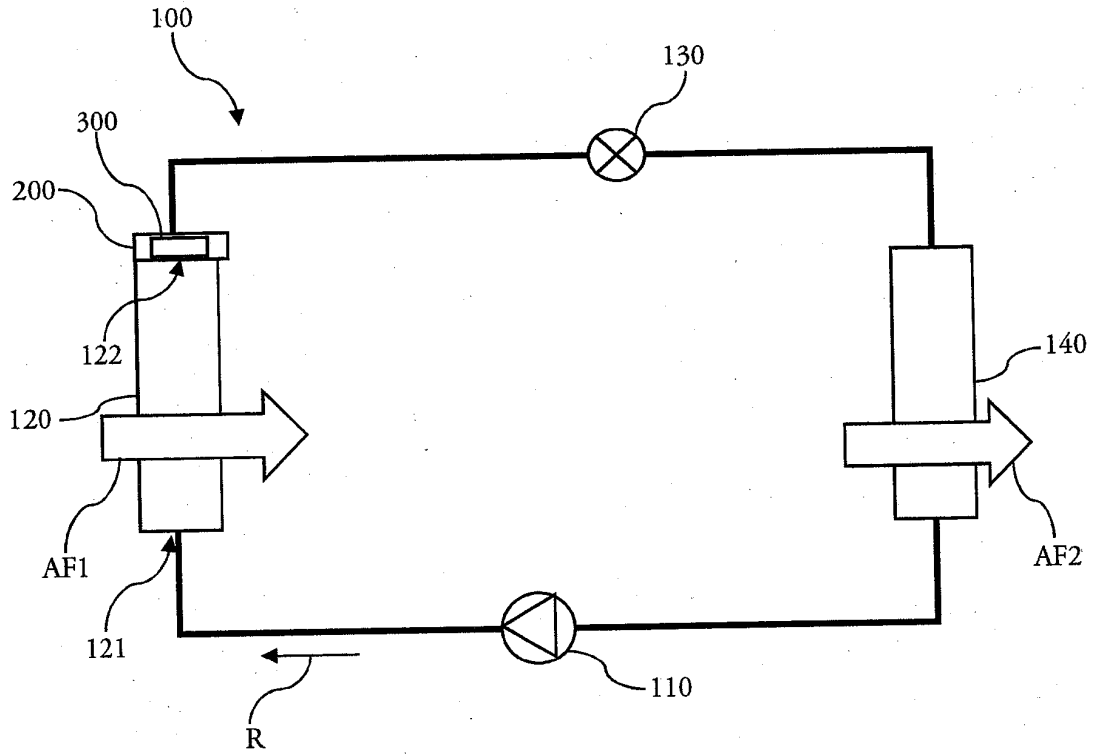

Fig. 1

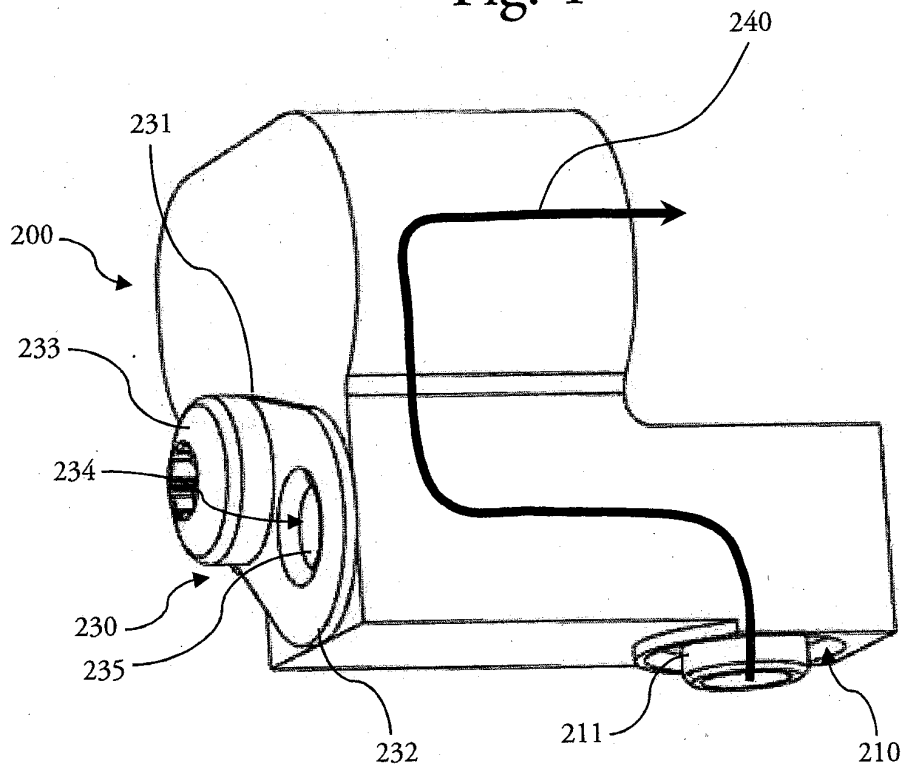

Fig. 2

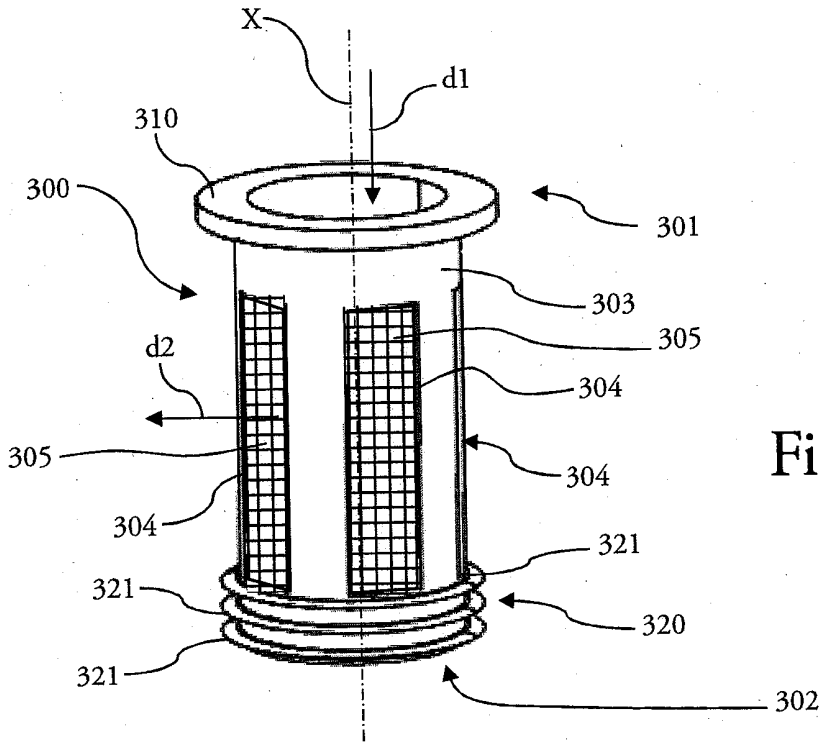

Fig. 3

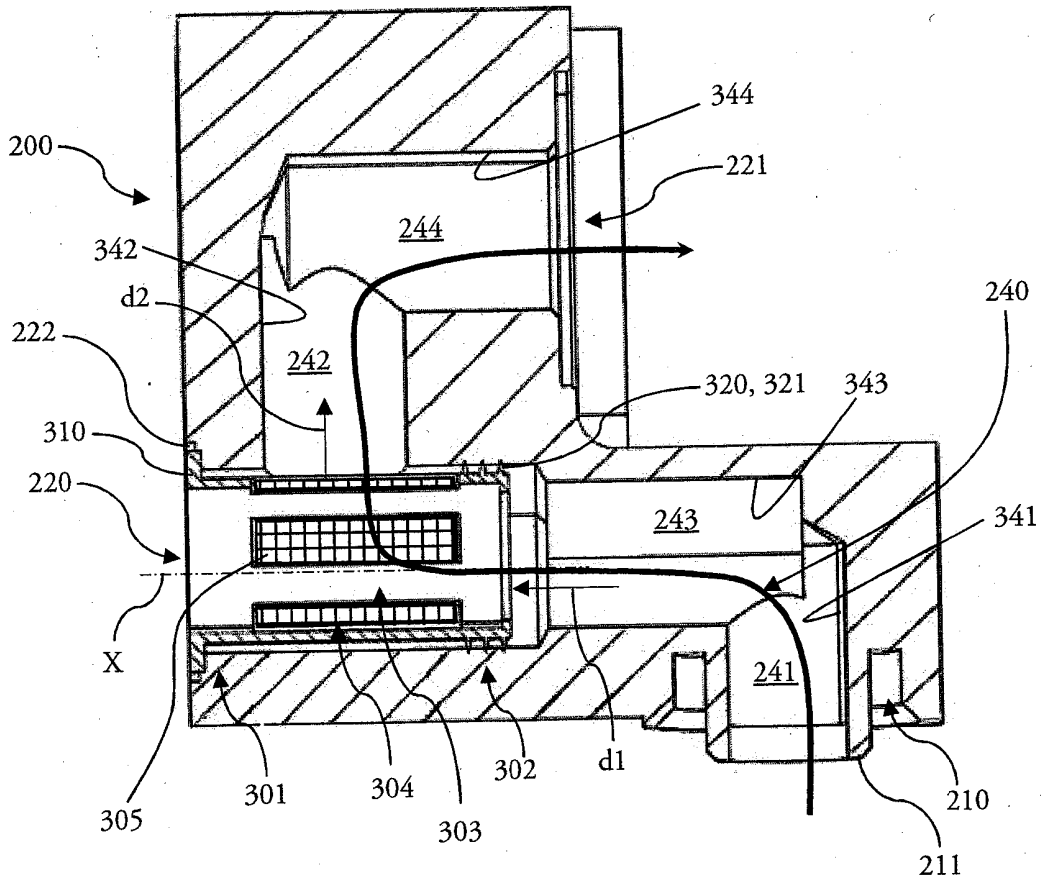

Fig. 4



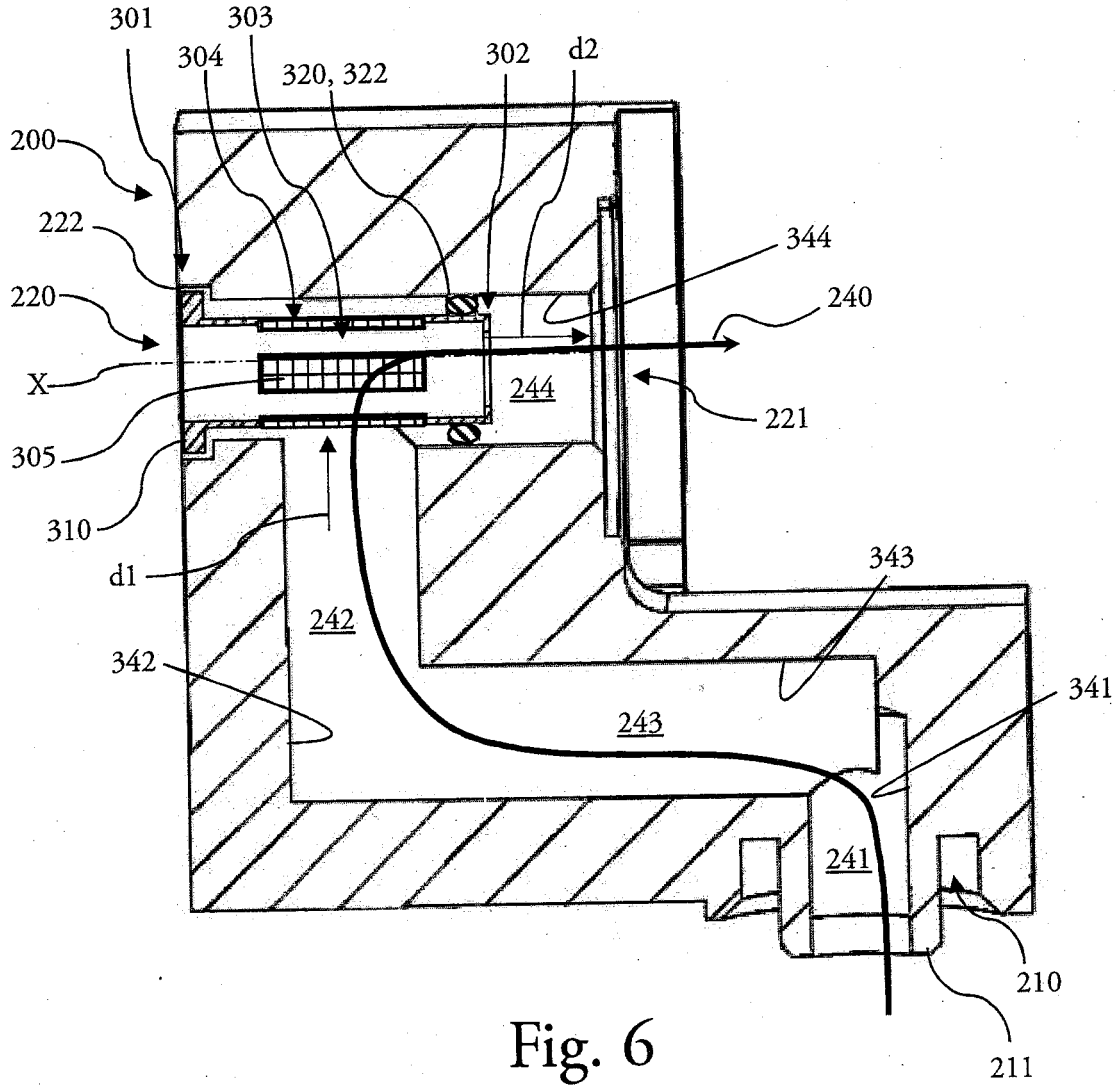

Fig. 6

**REFERENCES CITED IN THE DESCRIPTION**

*This list of references cited by the applicant is for the reader's convenience only. It does not form part of the European patent document. Even though great care has been taken in compiling the references, errors or omissions cannot be excluded and the EPO disclaims all liability in this regard.*

**Patent documents cited in the description**

- JP H06129733 A [0003]