

(12) **United States Design Patent** (10) **Patent No.:** **US D792,491 S**
Lin (45) **Date of Patent:** **** Jul. 18, 2017**

(54) **LINEAR ACTUATOR**

- (71) Applicant: **TIMOTION TECHNOLOGY CO., LTD.**, New Taipei (TW)
- (72) Inventor: **Yu-Chang Lin**, New Taipei (TW)
- (73) Assignee: **TIMOTION TECHNOLOGY CO., LTD.**, New Taipei (TW)
- (**) Term: **15 Years**
- (21) Appl. No.: **29/577,483**
- (22) Filed: **Sep. 13, 2016**
- (51) **LOC (10) Cl.** **15-09**
- (52) **U.S. Cl.**
 USPC **D15/143**; D15/148
- (58) **Field of Classification Search**
 USPC D12/345; D13/118, 158, 162, 184;
 D15/1-5, 7, 9, 143, 148, 149, 199
 CPC B66F 3/18; F16H 19/04; F16H 57/039;
 H01F 7/066
 See application file for complete search history.

(56) **References Cited**

U.S. PATENT DOCUMENTS

D137,967	S	*	5/1944	Wiener	254/103
D412,918	S	*	8/1999	Nagai	D15/149
D523,880	S	*	6/2006	Christensen	D15/143
D524,327	S	*	7/2006	Weiss	D15/7
D589,543	S	*	3/2009	Lin	D15/143
D665,433	S	*	8/2012	Beam	D15/143
D695,798	S	*	12/2013	Wu	D15/143
D776,729	S	*	1/2017	Wu	D15/143
D778,968	S	*	2/2017	Luck	D15/143

OTHER PUBLICATIONS

TiMotion TA2 Series Electric Cylinder/compact/small/DC, posted on directindustry.com, no posted date given, no production date given, [online], [site visited May 12, 2017], Available from Internet, <URL: http://www.directindustry.com/prod/timotion-technology-co-ltd/product-126233-1507829.html#product-item_1716532>.*

Feedback Linear Actuator, posted on progressiveautomations.com, no posted date given, no production date given, [online], [site visited 05/12/2017], Available from Internet, <URL: https://www.progressiveautomations.com/linear-actuator-with-potentiometer?gclid=CjwKEAjwutXIBRDV7-SDvdiNsUoSJACITqUfOVhXSN_b0FkSqNVK43z0IVUilGyxEzMvA3O7kTrxoCV0Dw_wcB>.*
 110-Lb. Capacity Linear Actuator, posted on northerntool.com, earliest review posted Jul. 29, 2014, no production date given, [online], [site visited May 12, 2017], Available from internet, <URL: http://www.northerntool.com/shop/tools/product_200520510_200520510>.*
 Feedback Rod Linear Actuators, posted on firgelliauto.com, earliest review posted Apr. 7, 2015, no production date given, [online], [site visited May 12, 2017], Available from Internet, <URL: <https://www.firgelliauto.com/products/feedback-rod-actuator#shopify-product-reviews>>.*

* cited by examiner

Primary Examiner — Melanie H Tung
Assistant Examiner — Fitzgerald Butac
 (74) *Attorney, Agent, or Firm* — Chun-Ming Shih; HDLS IPR Services

(57) **CLAIM**

The ornamental design for a linear actuator, as shown and described.

DESCRIPTION

FIG. 1 is a perspective view of a linear actuator showing my new design;
 FIG. 2 is a front view thereof;
 FIG. 3 is a rear view thereof;
 FIG. 4 is a left side view thereof;
 FIG. 5 is a right side view thereof;
 FIG. 6 is a top view thereof;
 FIG. 7 is a bottom view thereof;
 FIG. 8 is second perspective view thereof; and,
 FIG. 9 is a perspective view showing the linear actuator in use.
 The broken lines showing portions of a linear actuator form no part of the claimed design.

1 Claim, 9 Drawing Sheets

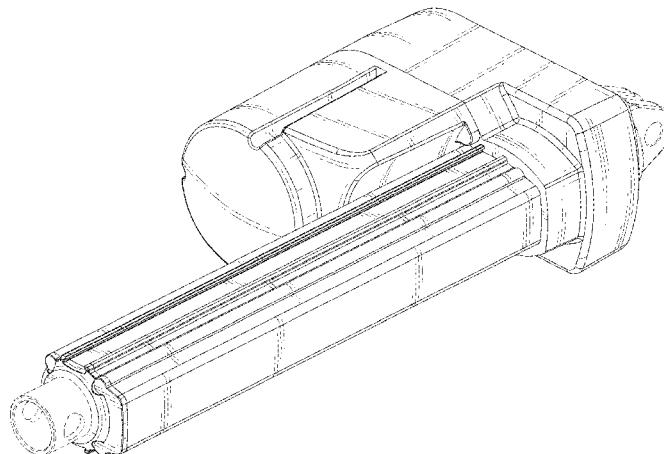

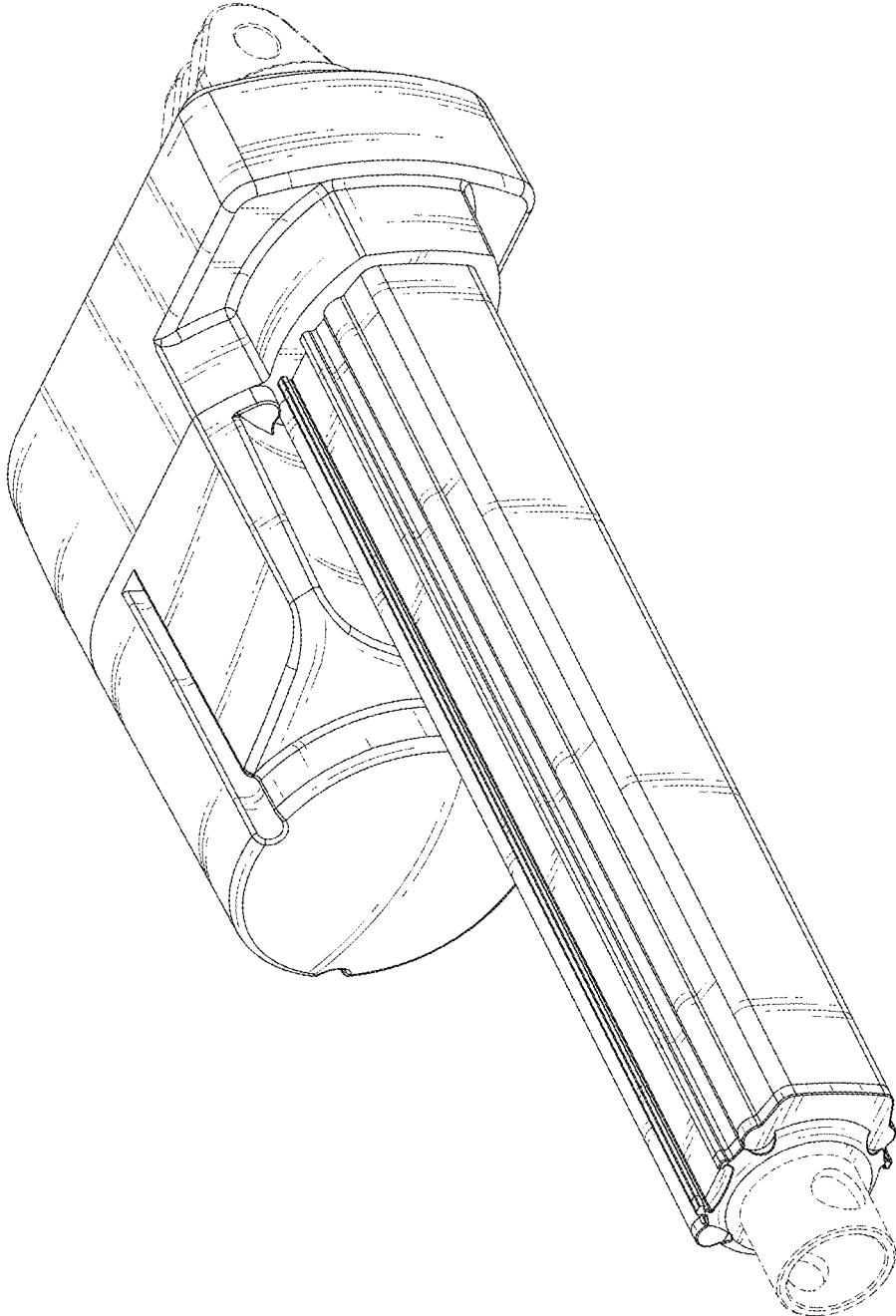

FIG.1

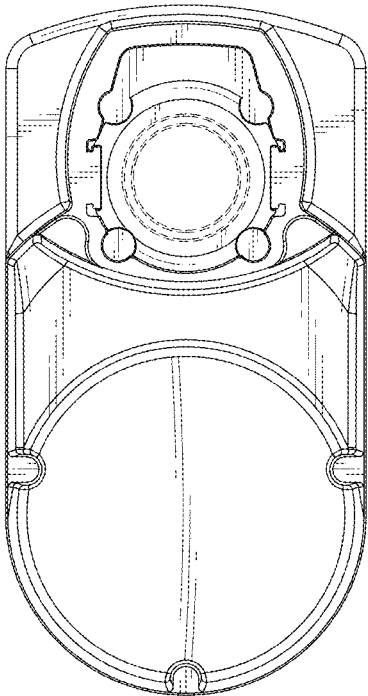

FIG.2

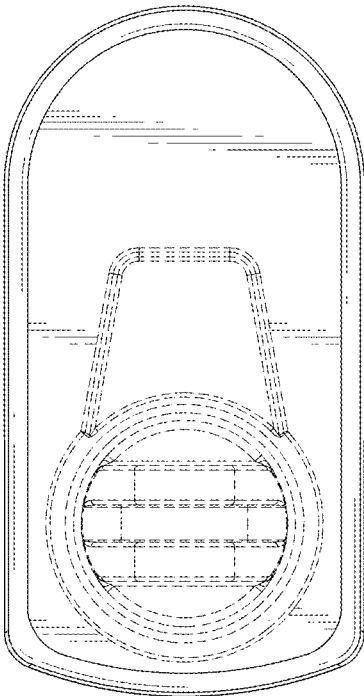

FIG.3

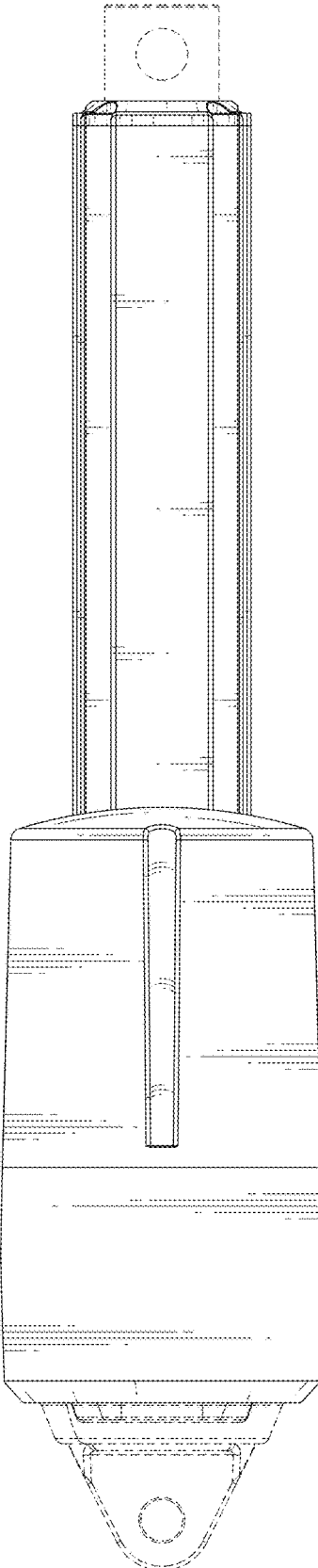

FIG.4

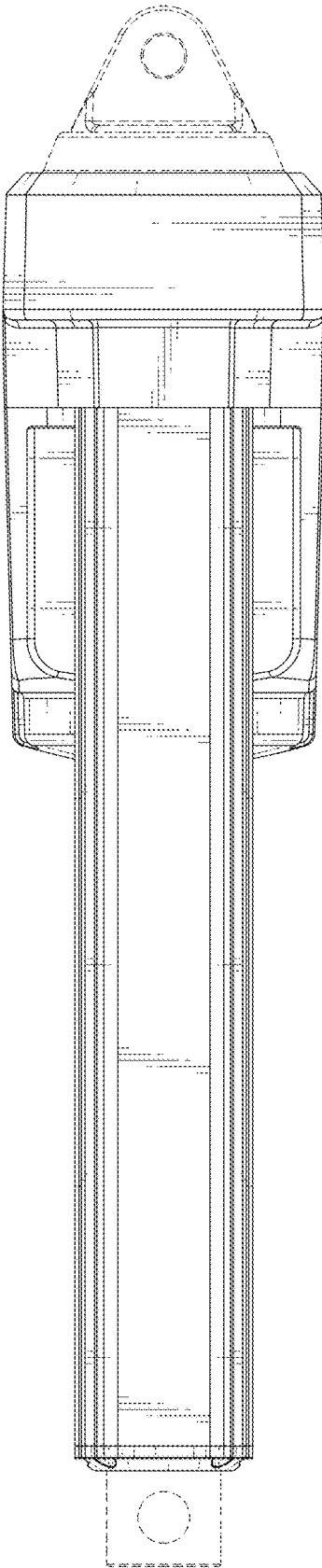

FIG.5

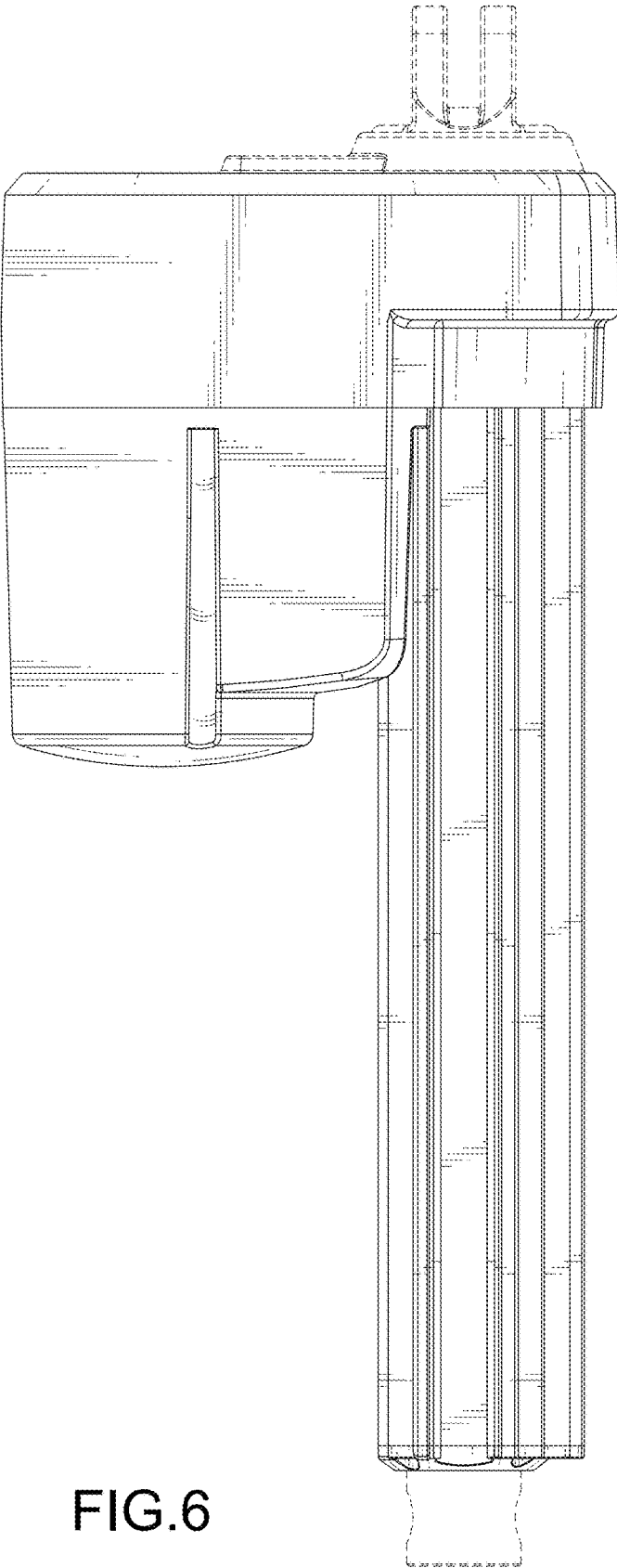

FIG.6

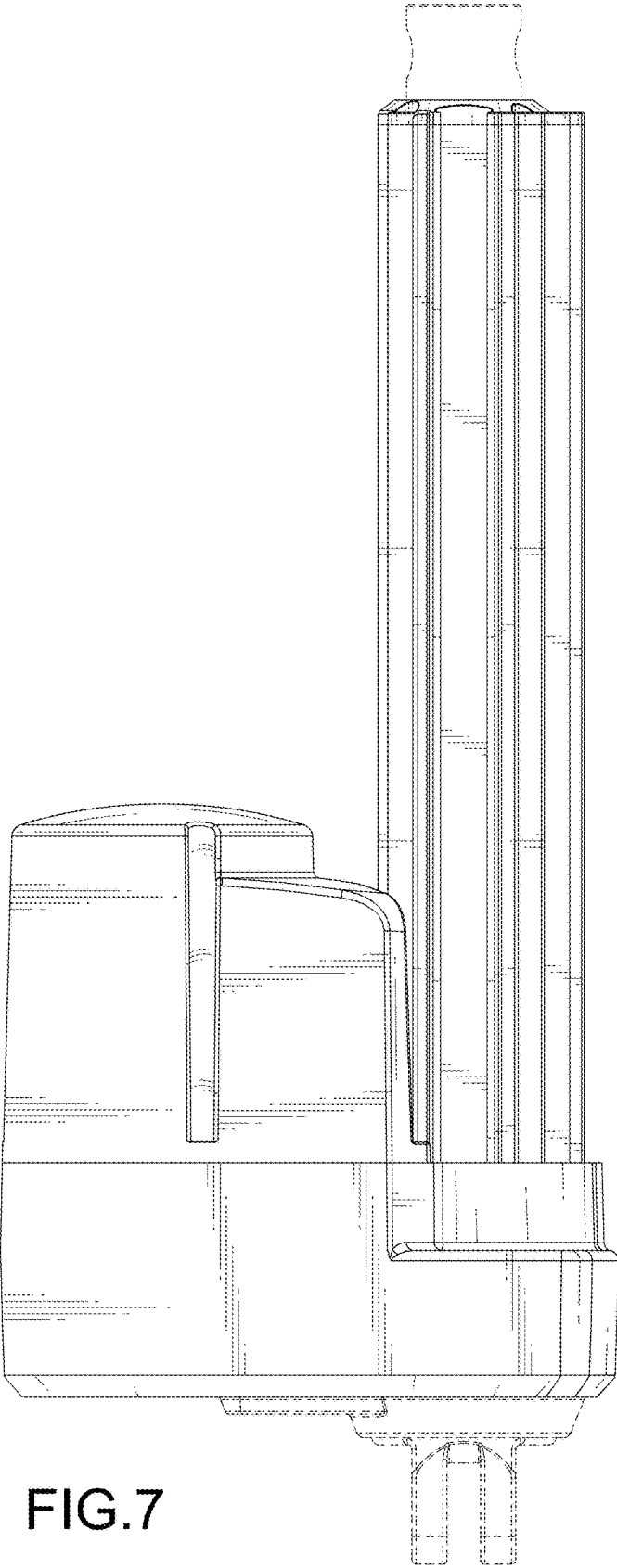

FIG. 7

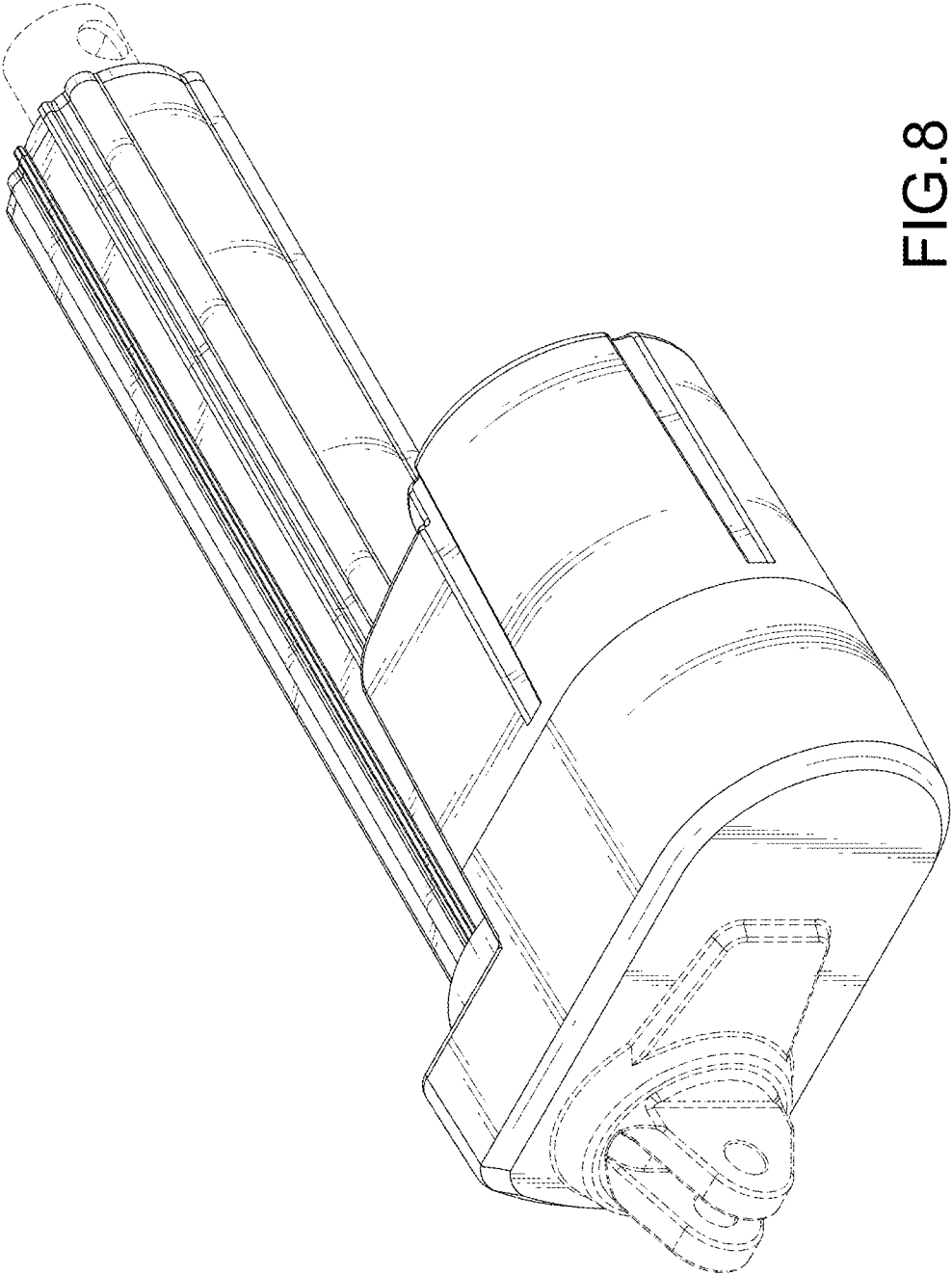

FIG. 8

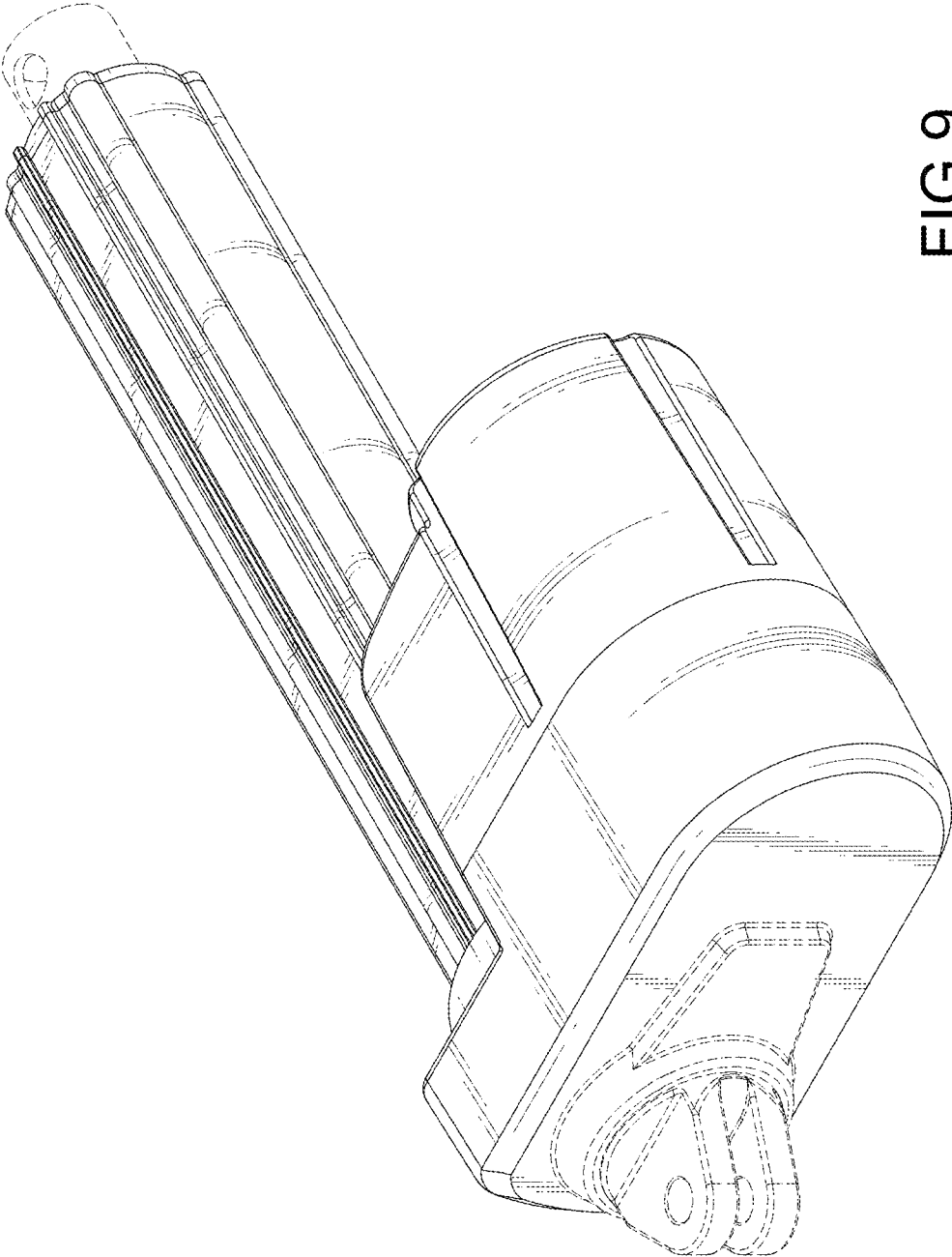

FIG.9