



(86) Date de dépôt PCT/PCT Filing Date: 2011/11/04  
 (87) Date publication PCT/PCT Publication Date: 2012/05/10  
 (85) Entrée phase nationale/National Entry: 2013/05/03  
 (86) N° demande PCT/PCT Application No.: US 2011/059362  
 (87) N° publication PCT/PCT Publication No.: 2012/061725  
 (30) Priorités/Priorities: 2010/11/05 (US61/410,603);  
 2011/05/19 (US61/487,846); 2011/10/19 (US13/276,673)

(51) Cl.Int./Int.Cl. *A61B 17/32* (2006.01),  
*A61B 18/14* (2006.01)  
 (71) Demandeur/Applicant:  
 ETHICON ENDO-SURGERY, INC., US  
 (72) Inventeurs/Inventors:  
 KIMBALL, CORY G., US;  
 PRICE, DANIEL W., US;  
 STROBL, GEOFFREY S., US  
 (74) Agent: NORTON ROSE FULBRIGHT CANADA  
 LLP/S.E.N.C.R.L., S.R.L.

(54) Titre : RETOUR D'INFORMATION A L'UTILISATEUR PAR L'INTERMEDIAIRE DE L'EFFECTEUR D'EXTREMITE  
 D'UN INSTRUMENT CHIRURGICAL  
 (54) Title: USER FEEDBACK THROUGH END EFFECTOR OF SURGICAL INSTRUMENT

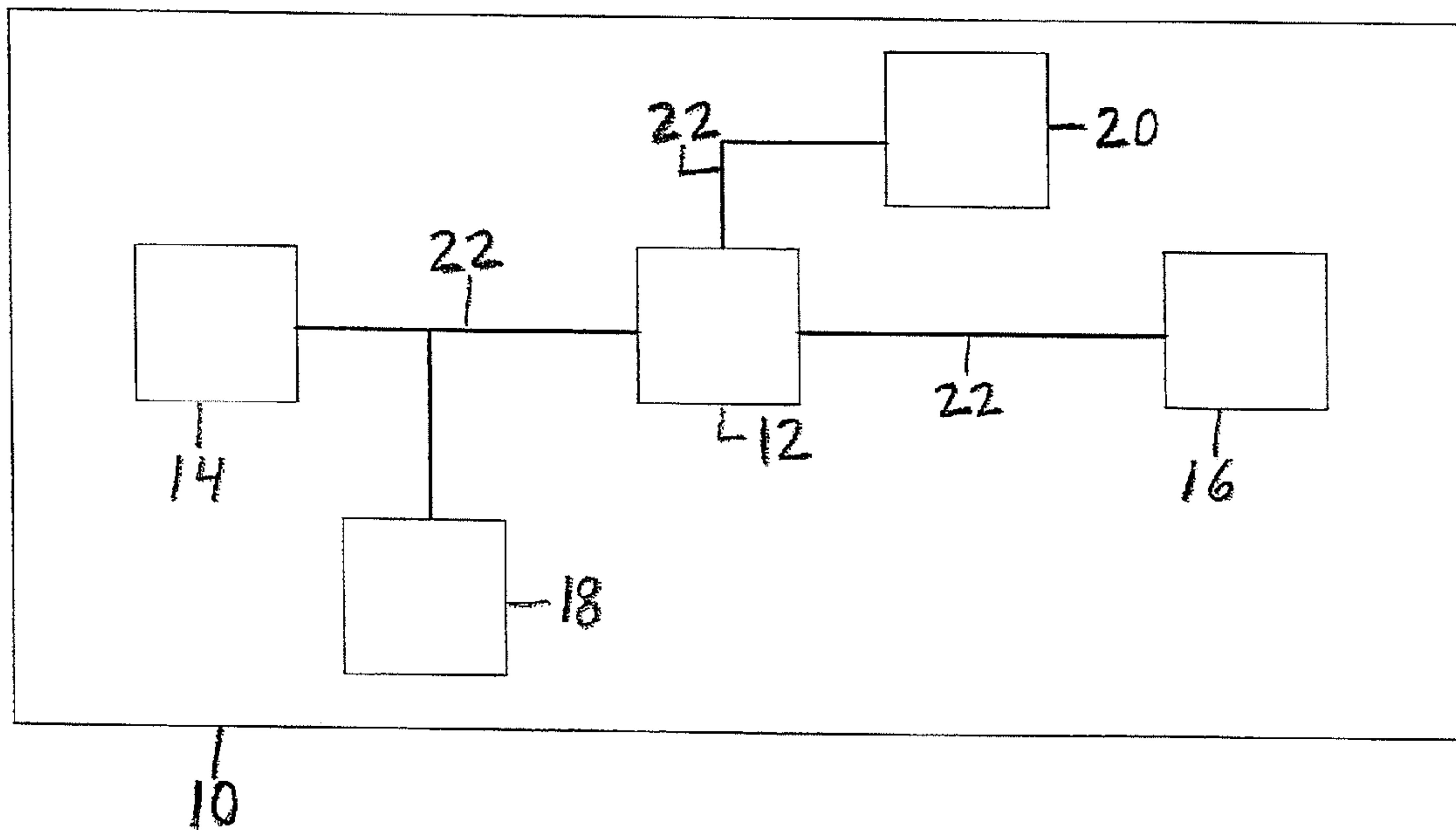

FIG. 1

(57) Abrégé/Abstract:

A surgical instrument includes a handle assembly and a transmission assembly including an end effector. The end effector includes a visual indicator, such as dots disposed on a clamp arm, to emit light from at least one LED disposed between the clamp arm and a clamp pad. The LED is connectable to a power source. An outer sheath of the end effector is extruded to include a first set of electrical conduits. A distal assembly of the end effector includes the clamp arm, clamp pad, LED, and a second set of electrical conduits to mate with the first set of electrical conduits when the distal assembly is snap-fit into the extruded outer sheath. An ultrasonic surgical instrument includes an outer sheath configured to transmit light from an internally housed LED along portions of the outer sheath.



## (12) INTERNATIONAL APPLICATION PUBLISHED UNDER THE PATENT COOPERATION TREATY (PCT)

(19) World Intellectual Property Organization  
International Bureau(43) International Publication Date  
10 May 2012 (10.05.2012)(10) International Publication Number  
**WO 2012/061725 A1**

## (51) International Patent Classification:

A61B 17/32 (2006.01) A61B 18/14 (2006.01)

## (21) International Application Number:

PCT/US2011/059362

## (22) International Filing Date:

4 November 2011 (04.11.2011)

## (25) Filing Language:

English

## (26) Publication Language:

English

## (30) Priority Data:

61/410,603	5 November 2010 (05.11.2010)	US
61/487,846	19 May 2011 (19.05.2011)	US
13/276,673	19 October 2011 (19.10.2011)	US

(71) Applicant (for all designated States except US):  
**ETHICON ENDO-SURGERY, INC.** [US/US]; 4545  
Creek Road, Cincinnati, OH 45242 (US).

## (72) Inventors; and

(75) Inventors/Applicants (for US only): **KIMBALL, Cory, G.** [US/US]; 6136 Lagrange Lane, Cincinnati, OH 45239 (US). **PRICE, Daniel, W.** [US/US]; 185 Overlook Drive, Loveland, OH 45140 (US). **STROBL, Geoffrey, S.** [US/US]; 15993 Colonial Drive, Williamsburg, OH 45176 (US).(74) Agents: **JOHNSON, Philip S.** et al.; Johnson & Johnson, One Johnson & Johnson Plaza, New Brunswick, NJ 08933 (US).

(81) Designated States (unless otherwise indicated, for every kind of national protection available): AE, AG, AL, AM, AO, AT, AU, AZ, BA, BB, BG, BH, BR, BW, BY, BZ, CA, CH, CL, CN, CO, CR, CU, CZ, DE, DK, DM, DO, DZ, EC, EE, EG, ES, FI, GB, GD, GE, GH, GM, GT, HN, HR, HU, ID, IL, IN, IS, JP, KE, KG, KM, KN, KP, KR, KZ, LA, LC, LK, LR, LS, LT, LU, LY, MA, MD, ME, MG, MK, MN, MW, MX, MY, MZ, NA, NG, NI, NO, NZ, OM, PE, PG, PH, PL, PT, QA, RO, RS, RU, RW, SC, SD, SE, SG, SK, SL, SM, ST, SV, SY, TH, TJ, TM, TN, TR, TT, TZ, UA, UG, US, UZ, VC, VN, ZA, ZM, ZW.

(84) Designated States (unless otherwise indicated, for every kind of regional protection available): ARIPO (BW, GH, GM, KE, LR, LS, MW, MZ, NA, RW, SD, SL, SZ, TZ, UG, ZM, ZW), Eurasian (AM, AZ, BY, KG, KZ, MD, RU, TJ, TM), European (AL, AT, BE, BG, CH, CY, CZ, DE, DK, EE, ES, FI, FR, GB, GR, HR, HU, IE, IS, IT, LT, LU, LV, MC, MK, MT, NL, NO, PL, PT, RO, RS, SE, SI, SK, SM, TR), OAPI (BF, BJ, CF, CG, CI, CM, GA, GN, GQ, GW, ML, MR, NE, SN, TD, TG).

## Declarations under Rule 4.17:

- as to the identity of the inventor (Rule 4.17(i))
- as to applicant's entitlement to apply for and be granted a patent (Rule 4.17(ii))
- as to the applicant's entitlement to claim the priority of the earlier application (Rule 4.17(iii))

[Continued on next page]

(54) Title: USER FEEDBACK THROUGH END EFFECTOR OF SURGICAL INSTRUMENT

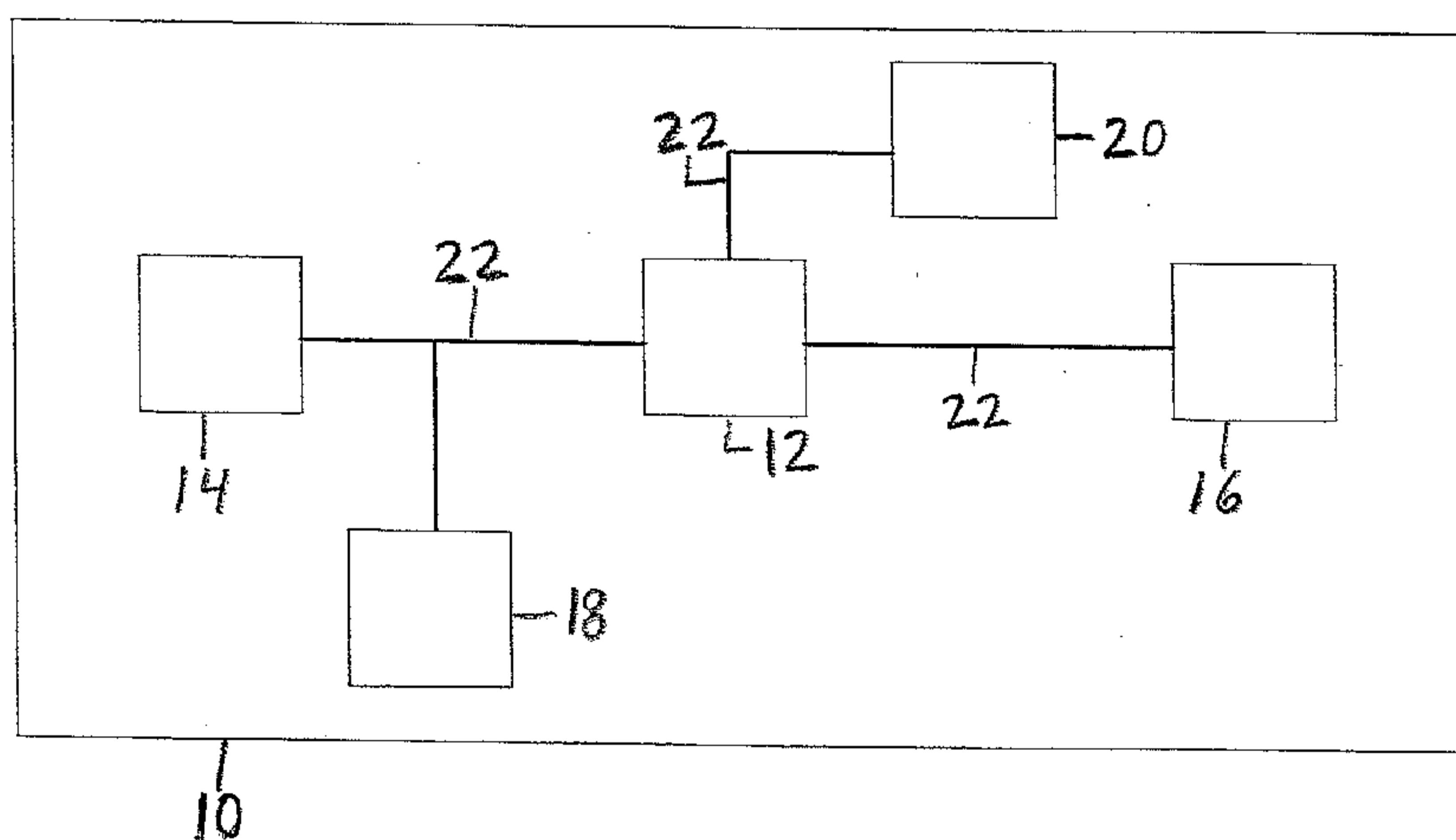

FIG. 1

(57) Abstract: A surgical instrument includes a handle assembly and a transmission assembly including an end effector. The end effector includes a visual indicator, such as dots disposed on a clamp arm, to emit light from at least one LED disposed between the clamp arm and a clamp pad. The LED is connectable to a power source. An outer sheath of the end effector is extruded to include a first set of electrical conduits. A distal assembly of the end effector includes the clamp arm, clamp pad, LED, and a second set of electrical conduits to mate with the first set of electrical conduits when the distal assembly is snap-fit into the extruded outer sheath. An ultrasonic surgical instrument includes an outer sheath configured to transmit light from an internally housed LED along portions of the outer sheath.

WO 2012/061725 A1

**WO 2012/061725 A1** 

---

**Published:**

— *with international search report (Art. 21(3))*

— *before the expiration of the time limit for amending the claims and to be republished in the event of receipt of amendments (Rule 48.2(h))*

## USER FEEDBACK THROUGH END EFFECTOR OF SURGICAL INSTRUMENT

## PRIORITY

- [0001] This application claims priority to U.S. Provisional Application Serial No. 61/410,603, filed November 5, 2010, entitled “Energy-Based Surgical Instruments,” the disclosure of which is incorporated by reference herein.
- [0002] This application also claims priority to U.S. Provisional Application Serial No. 61/487,846, filed May 19, 2011, entitled “Energy-Based Surgical Instruments,” the disclosure of which is incorporated by reference herein.
- [0003] This application also claims priority to U.S. Nonprovisional Application Serial No. 13/276,673 filed October 19, 2011, entitled “User Feedback Through End Effector of Surgical Instrument,” the disclosure of which is incorporated by reference herein.

## BACKGROUND

- [0004] In some settings, endoscopic surgical instruments may be preferred over traditional open surgical devices since a smaller incision may reduce the post-operative recovery time and complications. Consequently, some endoscopic surgical instruments may be suitable for placement of a distal end effector at a desired surgical site through a cannula of a trocar. These distal end effectors may engage tissue in a number of ways to achieve a diagnostic or therapeutic effect (e.g., endocutter, grasper, cutter, stapler, clip applier, access device, drug/gene therapy delivery device, and energy delivery device using ultrasound, RF, laser, etc.). Endoscopic surgical instruments may include a shaft between the end effector and a handle portion, which is manipulated by the clinician. Such a shaft may enable insertion to a desired depth and rotation about the longitudinal axis of the shaft, thereby facilitating positioning of the end effector within the patient.

[0005] Examples of endoscopic surgical instruments include those disclosed in U.S. Pat. Pub. No. 2006/0079874, entitled “Tissue Pad Use with an Ultrasonic Surgical Instrument,” published April 13, 2006, the disclosure of which is incorporated by reference herein; U.S. Pat. Pub. No. 2007/0191713, entitled “Ultrasonic Device for Cutting and Coagulating,” published August 16, 2007, the disclosure of which is incorporated by reference herein; U.S. Pat. Pub. No. 2007/0282333, entitled “Ultrasonic Waveguide and Blade,” published December 6, 2007, the disclosure of which is incorporated by reference herein; U.S. Pat. Pub. No. 2008/0200940, entitled “Ultrasonic Device for Cutting and Coagulating,” published August 21, 2008, the disclosure of which is incorporated by reference herein; U.S. Pat. Pub. No. 2009/0209990 entitled “Motorized Surgical Cutting and Fastening Instrument Having Handle Based Power Source,” published August 20, 2009, the disclosure of which is incorporated by reference herein; and U.S. Pat. Pub. No. 2010/0069940 entitled “Ultrasonic Device for Fingertip Control,” published March 18, 2010, the disclosure of which is incorporated by reference herein; U.S. Pat. Pub. No. 2011/0015660, entitled “Rotating Transducer Mount for Ultrasonic Surgical Instruments,” published January 20, 2011, the disclosure of which is incorporated by reference herein; U.S. Pat. No. 6,500,176, entitled “Electrosurgical Systems and Techniques for Sealing Tissue,” issued December 31, 2002, the disclosure of which is incorporated by reference herein; U.S. Pat. No. 7,416,101 entitled “Motor-Driven Surgical Cutting and Fastening Instrument with Loading Force Feedback,” issued August 26, 2008, the disclosure of which is incorporated by reference herein; U.S. Pat. No. 7,738,971 entitled “Post-Sterilization Programming of Surgical Instruments,” issued June 15, 2010, the disclosure of which is incorporated by reference herein; and U.S. Pat. Pub. No. 2011/0087218, entitled “Surgical Instrument Comprising First and Second Drive Systems Actuatable by a Common Trigger Mechanism,” published April 14, 2011, the disclosure of which is incorporated by reference herein. Additionally, such surgical tools may include a cordless transducer such as that disclosed in U.S. Pat. Pub. No. 2009/0143797, entitled “Cordless Hand-held Ultrasonic Cautery Cutting Device,” published June 4, 2009, the disclosure of which is incorporated by reference herein. In addition, the surgical instruments may be used, or adapted for use, in robotic-assisted surgery settings such as that disclosed in U.S. Pat. No. 6,783,524, entitled “Robotic

Surgical Tool with Ultrasound Cauterizing and Cutting Instrument,” issued August 31, 2004.

[0006] While several systems and methods have been made and used for surgical instruments, it is believed that no one prior to the inventors has made or used the invention described in the appended claims.

#### BRIEF DESCRIPTION OF THE DRAWINGS

[0007] While the specification concludes with claims which particularly point out and distinctly claim this technology, it is believed this technology will be better understood from the following description of certain examples taken in conjunction with the accompanying drawings, in which like reference numerals identify the same elements and in which:

[0008] FIG. 1 depicts a schematic view of an exemplary medical device having an internal power source;

[0009] FIG. 2 depicts a perspective view of an exemplary medical device having an internal power source;

[0010] FIG. 3 depicts a side elevational view of an exemplary surgical instrument including a visual indicator;

[0011] FIG. 4 depicts a partial side elevational view of a version of the end effector of FIG. 3 including an illuminating ring;

[0012] FIG. 5 depicts a fragmentary, perspective view of the end effector of FIG. 4;

[0013] FIG. 6 depicts a cross-sectional end view of an exemplary end effector including a clear plastic lens and one or more LEDs disposed below the clear plastic lens and about internal components of the end effector;

[0014] FIG. 7 depicts a perspective view of an exemplary alternative end effector shown to be operating on a tissue vessel, the end effector including a series of light-emitting dot

structures on a top surface of an upper clamp arm while an attached clamp pad grips the vessel;

[0015] FIG. 8 depicts a cross-sectional side view of the end effector of FIG. 7;

[0016] FIG. 9 depicts a perspective view of the exemplary end effector of FIG. 7 with the clamp arm and clamp pad removed;

[0017] FIG. 10 depicts a cross-sectional view of the extruded outer sheath of FIG. 8;

[0018] FIG. 11 depicts a side elevational view of an exemplary harmonic blade with an outer sheath capable of transmitting light along an entire length;

[0019] FIG. 12 depicts a side elevational view of an exemplary harmonic blade with an outer sheath including elongate localized areas capable of transmitting light from an internal LED source; and

[0020] FIG. 13 depicts a side elevational view of an exemplary harmonic blade with an outer sheath including localized dot areas capable of transmitting light from an internal LED source.

[0021] The drawings are not intended to be limiting in any way, and it is contemplated that various embodiments of the technology may be carried out in a variety of other ways, including those not necessarily depicted in the drawings. The accompanying drawings incorporated in and forming a part of the specification illustrate several aspects of the present technology, and together with the description serve to explain the principles of the technology; it being understood, however, that this technology is not limited to the precise arrangements shown.

#### DETAILED DESCRIPTION

[0022] The following description of certain examples of the technology should not be used to limit its scope. Other examples, features, aspects, embodiments, and advantages of the technology will become apparent to those skilled in the art from the following description, which is by way of illustration, one of the best modes contemplated for

carrying out the technology. As will be realized, the technology described herein is capable of other different and obvious aspects, all without departing from the technology. Accordingly, the drawings and descriptions should be regarded as illustrative in nature and not restrictive.

**[0023]** I. Exemplary Medical Device Overview

**[0024]** FIG. 1 shows components of an exemplary medical device (10) in diagrammatic block form. As shown, medical device (10) comprises a control module (12), a power source (14), and an end effector (16). Merely exemplary power sources (14) may include NiMH batteries, Li-ion batteries (e.g., prismatic cell type lithium ion batteries, etc.), Ni-Cad batteries, or any other type of power source as may be apparent to one of ordinary skill in the art in light of the teachings herein. Control module (12) may comprise a microprocessor, an application specific integrated circuit (ASIC), memory, a printed circuit board (PCB), a storage device (such as a solid state drive or hard disk), firmware, software, or any other suitable control module components as will be apparent to one of ordinary skill in the art in light of the teachings herein. Control module (12) and power source (14) are coupled by an electrical connection (22), such as a cable and/or traces in a circuit board, etc., to transfer power from power source (14) to control module (12). Alternatively, power source (14) may be selectively coupled to control module (12). This allows power source (14) to be detached and removed from medical device (10), which may further allow power source (14) to be readily recharged or reclaimed for resterilization and reuse, such as in accordance with the various teachings herein. In addition or in the alternative, control module (12) may be removed for servicing, testing, replacement, or any other purpose as will be apparent to one of ordinary skill in the art in view of the teachings herein.

**[0025]** End effector (16) is coupled to control module (12) by another electrical connection (22). End effector (16) is configured to perform a desired function of medical device (10). By way of example only, such function may include cauterizing tissue, ablating tissue, severing tissue, ultrasonically vibrating, stapling tissue, or any other desired task for medical device (10). End effector (16) may thus include an active feature

such as an ultrasonic blade, a pair of clamping jaws, a sharp knife, a staple driving assembly, a monopolar RF electrode, a pair of bipolar RF electrodes, a thermal heating element, and/or various other components. End effector (16) may also be removable from medical device (10) for servicing, testing, replacement, or any other purpose as will be apparent to one of ordinary skill in the art in view of the teachings herein. In some versions, end effector (16) is modular such that medical device (10) may be used with different kinds of end effectors (e.g., as taught in U.S. Provisional Application Serial No. 61/410,603, etc.). Various other configurations of end effector (16) may be provided for a variety of different functions depending upon the purpose of medical device (10) as will be apparent to those of ordinary skill in the art in view of the teachings herein. Similarly, other types of components of a medical device (10) that may receive power from power source (14) will be apparent to those of ordinary skill in the art in view of the teachings herein.

[0026] Medical device (10) of the present example includes a trigger (18) and a sensor (20), though it should be understood that such components are merely optional. Trigger (18) is coupled to control module (12) and power source (14) by electrical connection (22). Trigger (18) may be configured to selectively provide power from power source (14) to end effector (16) (and/or to some other component of medical device (10)) to activate medical device (10) when performing a procedure. Sensor (20) is also coupled to control module (12) by an electrical connection (22) and may be configured to provide a variety of information to control module (12) during a procedure. By way of example only, such configurations may include sensing a temperature at end effector (16) or determining the oscillation rate of end effector (16). Data from sensor (20) may be processed by control module (12) to effect the delivery of power to end effector (16) (e.g., in a feedback loop, etc.). Various other configurations of sensor (20) may be provided depending upon the purpose of medical device (10) as will be apparent to those of ordinary skill in the art in view of the teachings herein. Of course, as with other components described herein, medical device (10) may have more than one sensor (20), or sensor (20) may simply be omitted if desired.

[0027] FIG. 2 depicts a merely exemplary form that medical device (10) may take. In particular, FIG. 2 shows a medical device (100) comprising a power source (110), a control module (120), a housing (130), end effector (140), and an electrical connection (150). In the present example, power source (110) is located internally within housing (130) of medical device (100). Alternatively, power source (110) may only partially extend into housing (130) and may be selectively attachable to a portion of housing (130). In yet a further exemplary configuration, a portion of housing (130) may extend into power source (110) and power source (110) may be selectively attachable to the portion of housing (130). Power source (110) may also be configured to detach from medical device (100) and decouple from control module (120) or electrical connection (150). As a result, power source (110) may be completely separated from medical device (100) in some versions. By way of example only, power source (110) may be constructed in accordance with the teachings of U.S. Pub. No. 2011/0087212, entitled "Surgical Generator for Ultrasonic and Electrosurgical Devices," published April 14, 2011, the disclosure of which is incorporated by reference herein. In some versions, power source (110) may be removed to be recharged or reclaimed for reesterilization and reuse, such as in accordance with various teachings herein. After recharging, or after an initial charge, power source (110) may be inserted or reinserted into medical device (100) and secured to housing (130) or internally within housing (130). Of course, medical device (100) may also allow power source (110) to be charged and/or recharged while power source (110) is still in or otherwise coupled relative to housing (130).

[0028] It should also be understood that control module (120) may be removed for servicing, testing, replacement, or any other purpose as will be apparent to one of ordinary skill in the art in view of the teachings herein. Further, end effector (140) may also be removable from medical device (100) for servicing, testing, replacement, or any other purpose as will be apparent to one of ordinary skill in the art in view of the teachings herein.

[0029] While certain configurations of an exemplary medical device (100) have been described, various other ways in which medical device (100) may be configured will be apparent to those of ordinary skill in the art in view of the teachings herein. By way of

example only, medical devices (10, 100) and/or any other medical device referred to herein may be constructed in accordance with at least some of the teachings of U.S. Pat. No. 5,322,055 entitled "Clamp Coagulator/Cutting System for Ultrasonic Surgical Instruments," issued June 21, 1994, the disclosure of which is incorporated by reference herein; U.S. Pat. No. 5,873,873 entitled "Ultrasonic Clamp Coagulator Apparatus Having Improved Clamp Mechanism," issued February 23, 1999, the disclosure of which is incorporated by reference herein; U.S. Pat. No. 5,980,510, entitled "Ultrasonic Clamp Coagulator Apparatus Having Improved Clamp Arm Pivot Mount," filed October 10, 1997, the disclosure of which is incorporated by reference herein; U.S. Pat. No. 6,325,811 entitled "Blades with Functional Balance Asymmetries for use with Ultrasonic Surgical Instruments," issued December 4, 2001, the disclosure of which is incorporated by reference herein; U.S. Pub. No. 2006/0079874 entitled "Tissue Pad for Use with an Ultrasonic Surgical Instrument," published April 13, 2006, the disclosure of which is incorporated by reference herein; U.S. Pub. No. 2007/0191713 entitled "Ultrasonic Device for Cutting and Coagulating," published August 16, 2007, the disclosure of which is incorporated by reference herein; U.S. Pub. No. 2007/0282333 entitled "Ultrasonic Waveguide and Blade," published December 6, 2007, the disclosure of which is incorporated by reference herein; U.S. Pub. No. 2008/0200940 entitled "Ultrasonic Device for Cutting and Coagulating," published August 21, 2008, the disclosure of which is incorporated by reference herein; U.S. Pub. No. 2009/0143797, entitled "Cordless Hand-held Ultrasonic Cautery Cutting Device," published June 4, 2009, the disclosure of which is incorporated by reference herein; U.S. Pub. No. 2010/0069940 entitled "Ultrasonic Device for Fingertip Control," published March 18, 2010, the disclosure of which is incorporated by reference herein; U.S. Pub. No. 2011/0015660, entitled "Rotating Transducer Mount for Ultrasonic Surgical Instruments," published January 20, 2011, the disclosure of which is incorporated by reference herein; and/or U.S. Provisional Application Serial No. 61/410,603, filed November 5, 2010, entitled "Energy-Based Surgical Instruments," the disclosure of which is incorporated by reference herein.

**[0030]** Of course, housing (130) and medical device (100) may include other configurations. For instance, housing (130) and/or medical device (100) may include a tissue cutting element and one or more elements that transmit bipolar RF energy to tissue

(e.g., to coagulate or seal the tissue). An example of such a device is the ENSEAL® Tissue Sealing Device by Ethicon Endo-Surgery, Inc., of Cincinnati, Ohio. Further examples of such devices and related concepts are disclosed in U.S. Pat. No. 6,500,176 entitled “Electrosurgical Systems and Techniques for Sealing Tissue,” issued December 31, 2002, the disclosure of which is incorporated by reference herein; U.S. Pat. No. 7,112,201, entitled “Electrosurgical Instrument and Method of Use,” issued September 26, 2006, the disclosure of which is incorporated by reference herein; U.S. Pat. No. 7,125,409, entitled “Electrosurgical Working End for Controlled Energy Delivery,” issued October 24, 2006, the disclosure of which is incorporated by reference herein; U.S. Pat. No. 7,169,146 entitled “Electrosurgical Probe and Method of Use,” issued January 30, 2007, the disclosure of which is incorporated by reference herein; U.S. Pat. No. 7,186,253, entitled “Electrosurgical Jaw Structure for Controlled Energy Delivery,” issued March 6, 2007, the disclosure of which is incorporated by reference herein; U.S. Pat. No. 7,189,233, entitled “Electrosurgical Instrument,” issued March 13, 2007, the disclosure of which is incorporated by reference herein; U.S. Pat. No. 7,220,951, entitled “Surgical Sealing Surfaces and Methods of Use,” issued May 22, 2007, the disclosure of which is incorporated by reference herein; U.S. Pat. No. 7,309,849, entitled “Polymer Compositions Exhibiting a PTC Property and Methods of Fabrication,” issued December 18, 2007, the disclosure of which is incorporated by reference herein; U.S. Pat. No. 7,311,709, entitled “Electrosurgical Instrument and Method of Use,” issued December 25, 2007, the disclosure of which is incorporated by reference herein; U.S. Pat. No. 7,354,440, entitled “Electrosurgical Instrument and Method of Use,” issued April 8, 2008, the disclosure of which is incorporated by reference herein; U.S. Pat. No. 7,381,209, entitled “Electrosurgical Instrument,” issued June 3, 2008, the disclosure of which is incorporated by reference herein; U.S. Pub. No. 2011/0087218, entitled “Surgical Instrument Comprising First and Second Drive Systems Actuable by a Common Trigger Mechanism,” published April 14, 2011, the disclosure of which is incorporated by reference herein; and U.S. Pat. App. No. 13/151,181, entitled “Motor Driven Electrosurgical Device with Mechanical and Electrical Feedback,” filed June 2, 2011, the disclosure of which is incorporated by reference herein.

[0031] It is further understood that any one or more of the teachings, expressions,

embodiments, examples, etc. described herein may be combined with any one or more of the other teachings, expressions, embodiments, examples, etc. that are described herein. The following-described teachings, expressions, embodiments, examples, etc. should therefore not be viewed in isolation relative to each other. Various suitable ways in which the teachings herein may be combined will be readily apparent to those of ordinary skill in the art in view of the teachings herein. Such modifications and variations are intended to be included within the scope of the claims.

**[0032]** II. Exemplary Visual Indicators on Ultrasonic Surgical Instrument

**[0033]** Examples described below relate to uses of exemplary visual indicators on various surgical instruments, including but not limited to ultrasonic surgical instruments and electrosurgical devices. It should be understood that any of the instruments or devices (10, 100) referred to above and/or described in any of the references cited herein may readily incorporate any of the teachings below. Various suitable ways in which such teachings may be combined will be apparent to those of ordinary skill in the art. As will be described in greater detail below, visual indicators may be used to provide visual feedback regarding operating parameters, etc., of a surgical instrument. Throughout this disclosure, reference numbers utilized with different alphanumeric extensions indicate similar components in different versions of a described reference (i.e., surgical instruments (50, 50A)).

**[0034]** FIG. 3 shows exemplary instrument (50A) that is a variation of instrument (10, 100) described above. Upper surface (400) of multi-piece handle assembly (60A) includes lighting display (402). End effector (80A) of surgical instrument (50A) may additionally or alternatively include light display (404). Light displays (402, 404) may comprise light-emitting diodes (“LEDs”). Instrument (50A) includes power source (401), control module (403), and electrical connection (405), each respectively similar to power source (110), control module (120), and electrical connection (150) of instrument (100) described above. Power source (401) may comprise, for example, a battery. Alternatively, instrument (50A) may be powered by an external power source, such as the power source described in U.S. Pub. No. 2011/0087212. Control module (403) may, for

example, read information from sensors, process the sensor data to drive light display (404), and process the sensor data to control an actuation and clamping of end effector (80A).

[0035] FIGS. 4-5 show a version of end effector (80A) including light display (404) as illuminated ring (404A) disposed at a proximal end of end effector (80A). As shown in FIG. 5, ring (404A) may comprise at least one LED placed in clamp arm (84A) of end effector (80A). Referring back to FIG. 4, fiber optic cable (406) connects illuminated ring (404A) to a source (not shown) within instrument (50A), such as an electronics and/or battery cartridge housed within multi-piece handle assembly (60A). Mechanical connections (408) to end effector (80A) are disposed through a central aperture defined in illuminated ring (404A). Fiber optic cable (406) connects directly to illuminated ring (404A). Fiber optic cable (406) may carry light down shaft (410) of transmission assembly (70A) and through a lens on end effector (80A) to emit the light. Such light may present feedback to a surgeon that may be seen on a surgical monitor, preventing the need for the surgeon to look away from the surgical monitor or to listen for specific auditory tones providing information during surgery.

[0036] The one or more LEDs used for light display (402) and/or light display (404, 404A) may include a single multicolor LED or a multiple of LEDs in varying colors. In use, fiber optic cable (406) transmits light down shaft (410) to end effector (80A), as described above. Additionally, the entire shaft (410) may comprise a transparent tube able to emit light from an LED housed within multi-piece handle assembly (60A). Referring to FIG. 6, clear lens (420) may be included as part of shaft (410) of end effector (80A). At least one LED (418) may be positioned under lens (420) and outside of internal device components (422) to transmit light through lens (420) that is not substantially interrupted and is visible to an operating surgeon using instrument (50A). Lens (420) may additionally comprise a frosted finish or any other suitable finish to diffuse the emitted light and make lens (420) appear to glow. End effector (80A) may include an incorporated lens to emit the received light, which may be used to signal various conditions or information to the surgeon using surgical instrument (50A).

[0037] Such information may include, among other things, an indication of the status of surgical instrument (50A), such as indications of cycle completion, an indication of power activation or deactivation, an indication of an approaching overload of instrument (50A), an indication of battery power, an indication of a need for an such, as for an improperly working instrument (50A), the temperature of end effector (80A), the application of energy, and/or the sealing status of tissue being operated upon by instrument (50A). For example, the light may turn red to indicate a heated end effector (80A) and blue to indicate a cool end effector (80A). Or, a pulsation of the light may signal when energy is being applied through end effector (80A) while a solid light may indicate energy is no longer being applied through end effector (80A). Additionally or alternatively, a yellow light may signal a caution or warning that instrument (50A), including but not limited to warnings that instrument (50A) is not properly working, is not ready to seal tissue, or itself was not used properly by the operating surgeon.

[0038] Adequate brightness of any of light displays (402, 404, 404A) may allow an operating surgeon and user of instrument (50A) to detect a changing color emitted by the respective light display in the user's vision. Light may be emitted, for example, as a glow that progressively changes from yellow to orange to red to communicate an increasing heat of a blade when in use, for example. Or an LED may glow and emit a different color to communicate that an overload is being approached as too much pressure is being applied upon tissue. Additionally or alternatively, shaft (410) may be printed or labeled with an organic LED ("OLED"); in which an emissive electroluminescent layer of an LED is a film of organic compounds that emit light responsive to an electric current) to eliminate the need to transmit light down shaft (410). Instead, an electrical connection may supply power necessary to illuminate the OLED material on shaft (410).

[0039] Referring back to FIG. 13, ring (404A) provides visual feedback to a surgeon using instrument (50A) in a procedure that tissue vessel (414) being operated upon which has been severed is in the process of being sealed or has a completed seal. For example, ring (404A) may flash when the sealing process starts and may become solid when the sealing status of vessel (414) of tissue (90), as described above, is complete. In use,

when power is activated for instrument (50A), ring (404A) may turn on and blink with a light. Once a predetermined amount of time passes, the light from ring (404A) may stop blinking and become solid to indicate completion of the seal on vessel (414), as described above. Ring (404A) may use either a time algorithm to determine when to emit a solid light indicating sealing completion. Alternatively, ring (404A) may utilize a generator algorithm based on impedance to determine when to emit the solid light.

**[0040]** By emitting such light through ring (404A) or through a light pipe on end effector (80A), a surgeon may have visibility of that status of the sealing of vessel (414) at varying orientations of end effector (80A). Combining this effector with an audible change tone based on a generator algorithm indicated completion of a seal, multiple levels of feedback may be provided to a surgeon to indicate completion of the seal.

**[0041]** FIG. 7 shows exemplary instrument (50B) that is a variation of instrument (10, 100, 50A) described above. Instrument (50B) includes an end effector (80B) having a clamp arm (84B). Clamp arm (84B) includes small holes (416) allowing light from at least one LED, such as LED (418) of FIG. 6, to pass through. In use during a laparoscopic procedure, for example, light passing through holes (416) may be easily visible to an operating surgeon using instrument (50B) and would allow various types of information, as described above, to be communicated to the surgeon during the procedure.

**[0042]** Small holes (416) on top surface (424) of end effector (80B) may glow in various colors to emit light from end effector (80B) indicating certain information. End effector (80B) may include a molded interconnect device as described below and an illuminated clamp pad (86B). FIG. 8 shows tri-color LED (426) disposed in a cavity between upper clamp arm (84C) and clamp pad (86C) of end effector (80C). Light from LED (426) may glow and/or morph into various colors, and the light from LED (426) may be communicated and emitted through clamp pad (86B) and through holes (416) of clamp arm (84C) via one or more light pipe structures. Light may emit from two or more holes (416) simultaneously and/or at different times. With light emitting from holes (416) at different times, different sequences of emitted light may indicate different information.

A light display emitted via holes (416) in a certain sequence may indicate information about the sealing process of tissue (90) as effected by end effector (80B). For example, a pair of rear lights of holes (416) may illuminate during a beginning time of the sealing processes. As the sealing progresses, more lights may begin to illuminate in a distal direction. The eventual illumination of all holes (416), including the pair of rear lights as well as a pair of front lights and those lights disposed therebetween that together comprise holes (416), may indicate a completed sealing of tissue (90) by end effector (80B).

**[0043]** Proximal end (428) of distal assembly (430) of end effector (80B) may snap into extruded outer tube or sheath (72B), described below, in the direction of arrow (A), as shown in FIGS. 8 and 9. One or more protrusions (432) extending from proximal end (428) of distal assembly (430) may snap into one or more notches (434) in outer sheath (72B). In the present example, distal assembly (430) includes an injection molded distal outer tube (436) from which protrusions (432) extend. Outer sheath (72B) is extruded and includes two electrical conduits (438) running through and within a length of outer sheath (72B). Outer tube (436) includes electrical conduits (440) that mate with electrical conduits (438) when outer tube (436) is coupled with extruded outer sheath (72B), such that electrical and mechanical connections are achieved simultaneously. A similar connection may be made for sheaths of ultrasonic instruments that comprise light pipes, as described in greater detail below. For example, a light connection is made similar to the manner the electrical connection is described above in the sense that a conduit such as a fiber optic cable may connect an internal LED to a light pipe sheath.

**[0044]** Conduits (440) are in electrical communication with LED (426) within clamp arm (84B) via wires (441) positioned between clamp pad (86C) and clamp arm (84B). Electrical conduits (440), wires (441), and conduits (438) together provide a signal from instrument (50B) to light LED (426). Light emitted from LED (426) illuminates semi-translucent clamp pad (86B) and shines through small holes (416) of clamp arm (84B), as described above.

[0045] Referring to FIG. 8, clamp arm (84B) may pivot with respect to outer tube (436) via pin (442) and be connected to a lower clamp arm via pin (444), similar to a manner described above for instrument (50). FIG. 9 shows distal assembly (430) without clamp arm (84B) and clamp pad (86B) attached. Aperture (446) is disposed in outer tube (436) and is configured to receive pivot pin (442) of clamp arm (84B). FIG. 10 shows a cross-sectional view of extruded outer sheath (72B) housing an inner tubular actuating member (448) and a harmonic blade (82B). Inner tubular actuating member (448) is translatable within outer sheath (72B) to selectively pivot clamp arm (84B) toward and away from blade (82B), as described above in various references cited herein. Blade (82B) is selectively activated with ultrasonic energy, as described in various references cited herein. Two electrical leads or electrical conduits (438) are molded within outer sheath (72B). The molded interconnect device design on extruded outer sheath (72B) thus contains electrical leads or conduits (438) that connect to distal assembly (430) as described above to power LED (426) inside clamp arm (84B), allowing a glow to be emitted in different colors to provide visual feedback to a user such as a surgeon. The glow may be a progressive change of color and/or an emission of different colors as described above.

[0046] FIGS. 11-13 show three different versions of respective sheaths (450, 452, 454) of ultrasonic surgical instruments (456, 458, 460) including harmonic blades (462, 464, 466). Ultrasonic surgical instruments (456, 458, 460) may be alternate versions of surgical instrument (50) or device (310) or other surgeon training tools. FIG. 11 shows a version in which the entire sheath (450) is a frosted clear material or light pipe communicating light from an internal LED, such as LED (418) described above, to a user of device (456). FIGS. 12 and 13 show two other versions of sheaths (452, 454) wherein selective areas of respective sheaths (452, 454) do not transmit light from LED (418), for example. FIG. 12 includes elongate localized areas (468) on sheath (452) that are light piped. Sheath (452) may include two portions, solid opaque tube (472) and light pipe tube (474) within outer solid opaque tube (472) that only shows through outer tube (472) in localized areas (468). FIG. 13 shows areas of sheath (454) including dots (470) that are light piped. For example, sheath (454) may comprise a clear material that is coated

with an opaque coating and only emits light in localized areas, such as those defined by dots (470).

**[0047]** By viewing sheaths (450, 452, 454) of respective devices (456, 458, 460) during use, users of such devices may be provided with a visible indication of information such as how much force is being applied to respective blades (462, 464, 466). Force may either be measured by an increase in impedance on a respective blade (462, 464, 466) or by using bend sensors housed within a respective device shroud to determine how much force is being applied to a respective blade sheath assembly. Such devices could thus be used to assist with training surgeons on proper amounts of force to be used and technique necessary to optimize tissue effects during surgical operations such as laparoscopic tissue operations to sever tissue as described herein and as described in various references cited herein. Thus, when force is being applied to a respective blade (462, 464, 466) against tissue, and the force begins to increase, the respective lighted sheath may change color from green to yellow to orange and finally to red, for example, to indicate a final point for either hitting a solid tone, indicating too much force is being applied by a user via respective blade (462, 464, 466), or being submitted an error code. When using respective device (456, 458, 460), a user such as a surgeon may understand that a green or yellow sheath implies the surgeon is applying a correct amount of force against tissue and an orange or red sheath implies the application of too much force against tissue.

**[0048]** It should be understood that any one or more of the teachings, expressions, embodiments, examples, etc. described herein may be combined with any one or more of the other teachings, expressions, embodiments, examples, etc. that are described herein. The following-described teachings, expressions, embodiments, examples, etc. should therefore not be viewed in isolation relative to each other. Various suitable ways in which the teachings herein may be combined will be readily apparent to those of ordinary skill in the art in view of the teachings herein. Such modifications and variations are intended to be included within the scope of the claims.

- [0049] Versions of the devices described above may have application in conventional medical treatments and procedures conducted by a medical professional, as well as application in robotic-assisted medical treatments and procedures.
- [0050] Versions of described above may be designed to be disposed of after a single use, or they can be designed to be used multiple times. Versions may, in either or both cases, be reconditioned for reuse after at least one use. Reconditioning may include any combination of the steps of disassembly of the device, followed by cleaning or replacement of particular pieces, and subsequent reassembly. In particular, some versions of the device may be disassembled, and any number of the particular pieces or parts of the device may be selectively replaced or removed in any combination. Upon cleaning and/or replacement of particular parts, some versions of the device may be reassembled for subsequent use either at a reconditioning facility, or by a user immediately prior to a procedure. Those skilled in the art will appreciate that reconditioning of a device may utilize a variety of techniques for disassembly, cleaning/replacement, and reassembly. Use of such techniques, and the resulting reconditioned device, are all within the scope of the present application.
- [0051] By way of example only, versions described herein may be sterilized before and/or after a procedure. In one sterilization technique, the device is placed in a closed and sealed container, such as a plastic or TYVEK bag. The container and device may then be placed in a field of radiation that can penetrate the container, such as gamma radiation, x-rays, or high-energy electrons. The radiation may kill bacteria on the device and in the container. The sterilized device may then be stored in the sterile container for later use. A device may also be sterilized using any other technique known in the art, including but not limited to beta or gamma radiation, ethylene oxide, or steam.
- [0052] Having shown and described various versions in the present disclosure, further adaptations of the methods and systems described herein may be accomplished by appropriate modifications by one of ordinary skill in the art without departing from the scope of the present invention. Several of such potential modifications have been mentioned, and others will be apparent to those skilled in the art. For instance, the

examples, versions, geometrics, materials, dimensions, ratios, steps, and the like discussed above are illustrative and are not required. Accordingly, the scope of the present invention should be considered in terms of the following claims and is understood not to be limited to the details of structure and operation shown and described in the specification and drawings.

I/We claim:

1. A surgical instrument comprising:
  - (a) a body;
  - (b) a transmission assembly extending distally from the body;
  - (c) an end effector at a distal end of the transmission assembly, wherein the end effector is operable to deliver energy from the transmission assembly to a surgical site; and
  - (d) a visual indicator on the transmission assembly or the end effector, wherein the visual indicator is operable to visually indicate an operating parameter associated with the end effector.
2. The surgical instrument of claim 1, further comprising a lighting device disposed on the body.
3. The surgical instrument of claim 1, wherein the visual indicator comprises a lighting device disposed on the end effector.
4. The surgical instrument of claim 1, wherein the end effector comprises one or more fiber optic cables communicating with the surgical instrument to transmit light through visual indicator on the end effector.
5. The surgical instrument of claim 1, wherein the end effector comprises at least one of clamp arm, wherein the visual indicator comprises a ring configured for illumination, wherein the ring is disposed proximal to the at least one clamp arm.
6. The surgical instrument of claim 1, wherein the end effector comprises a shaft, wherein the shaft comprises a clear lens, wherein the visual indicator comprises one or more LEDs disposed below the clear lens.
7. The surgical instrument of claim 1, wherein the end effector comprises an upper

- clamp arm, wherein the visual indicator comprises one or more LEDs, wherein the upper clamp arm comprises a series of holes configured to transmit light from the one or more LEDs.
8. The surgical instrument of claim 7, wherein the end effector further comprises a lower clamp pad attached to the upper clamp arm, wherein the one or more LEDs are disposed between the upper clamp arm and the lower clamp pad.
  9. The surgical instrument of claim 8, wherein the end effector further comprises a distal assembly and an extruded outer sheath, wherein a first set of electrical conduits extend from the one or more LEDs through the distal assembly, wherein the distal assembly is configured to be removably attached to a proximal end of the extruded outer sheath.
  10. The surgical instrument of claim 9, wherein the extruded outer sheath is injection molded and comprises a second set of electrical conduits, wherein the second set of electrical conduits is configured for an electrical connection to the first set of electrical conduits when the distal assembly is attached to the extruded outer sheath.
  11. The surgical instrument of claim 9, wherein the distal assembly includes one or more of one of protrusions or notches configured to be received in one or more of the other of protrusions or notches disposed in the extruded outer sheath.
  12. The surgical instrument of claim 9, wherein the distal assembly is configured to be removably attached to the proximal end of the extruded outer sheath in a snap-fit connection.
  13. The surgical instrument of claim 9, wherein the distal assembly comprises a molded distal outer tube, wherein the upper clamp arm is pivotally connected to the molded distal outer tube.

14. The surgical instrument of claim 7, wherein the one or more LEDs emit a glow configured to be emitted in at least one of a series of colors.
15. The surgical instrument of claim 14, wherein each color is associated with a temperature level of a blade of the end effector.
16. An ultrasonic surgical instrument comprising:
  - (a) a sheath;
  - (b) a harmonic blade extending from the sheath; and
  - (c) an LED housed in the ultrasonic surgical instrument, wherein the LED is responsive to forces exerted at the harmonic blade;wherein the sheath comprises light-transmitting portions configured to transmit light from the LED.
17. The instrument of claim 16, wherein the entire sheath comprises a frosted clear material and is configured to transmit light from the LED.
18. The instrument of claim 16, wherein the sheath comprising a solid opaque tube and a light pipe tube disposed within the solid opaque tube, and the solid opaque tube comprises elongate localized areas, and wherein light from the LED and light pipe tube are transmitted only through the elongate localized areas.
19. The instrument of claim 16, wherein the sheath comprises a series of dots comprising localized areas, and wherein the dots are light piped to transmit light from the LED only through the localized areas.
20. A surgical instrument comprising:
  - (a) a body;
  - (b) a shaft extending distally from the body;
  - (c) one or more LEDs housed within a distal end of the shaft, wherein each

LED is operable to visually indicate an operating parameter associated with the distal end of the shaft.

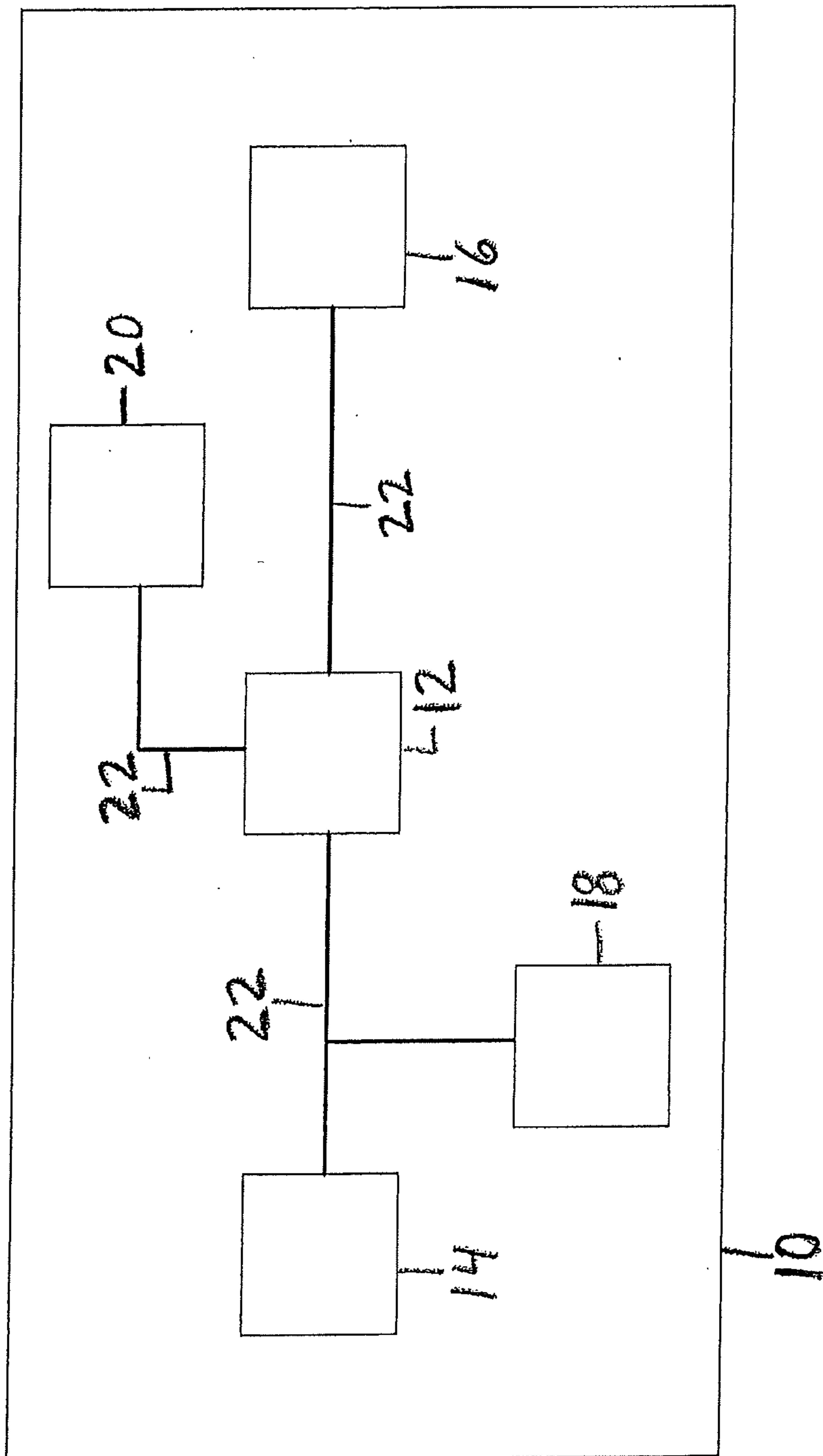

FIG. 1

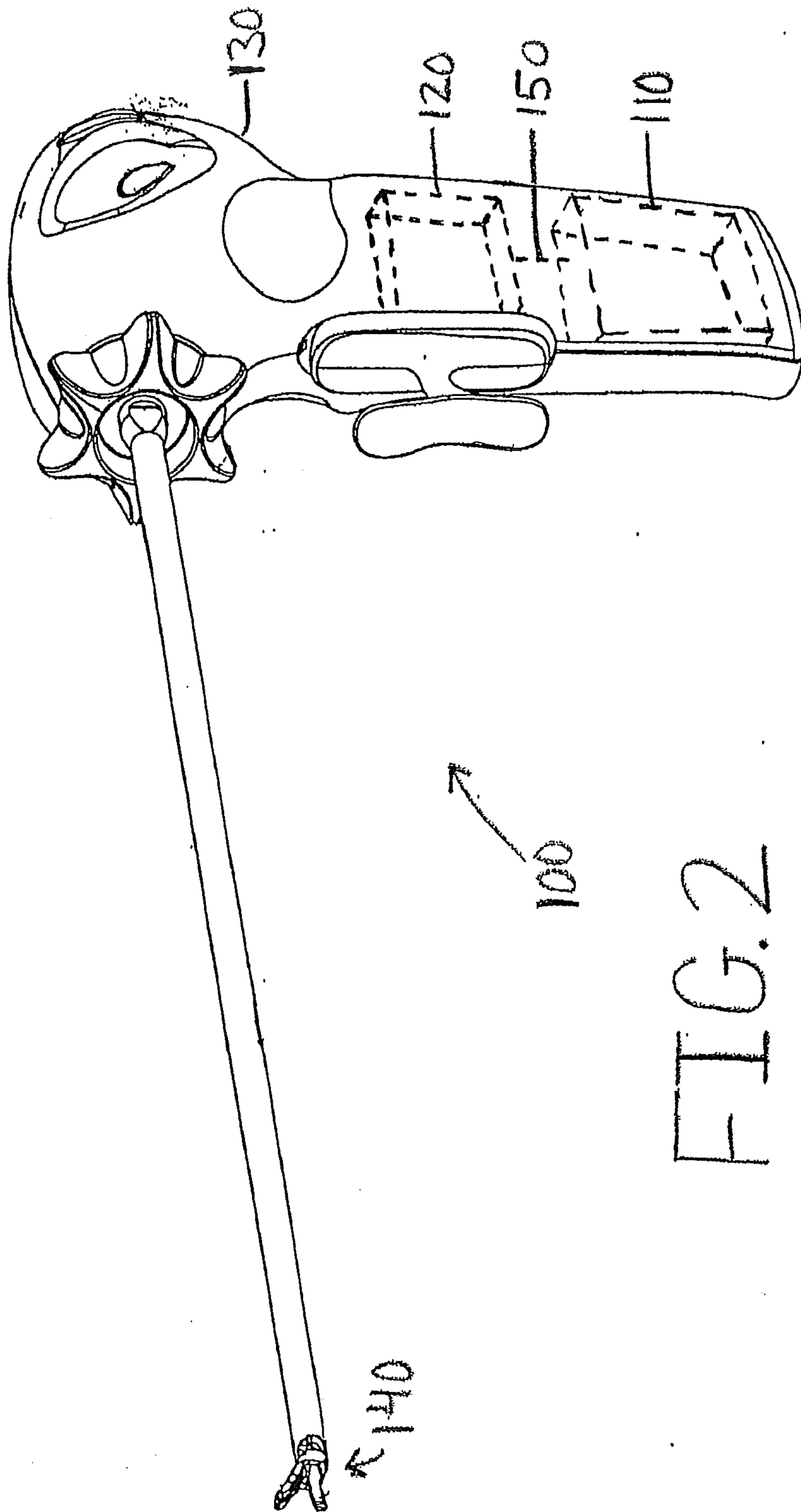

FIG. 2

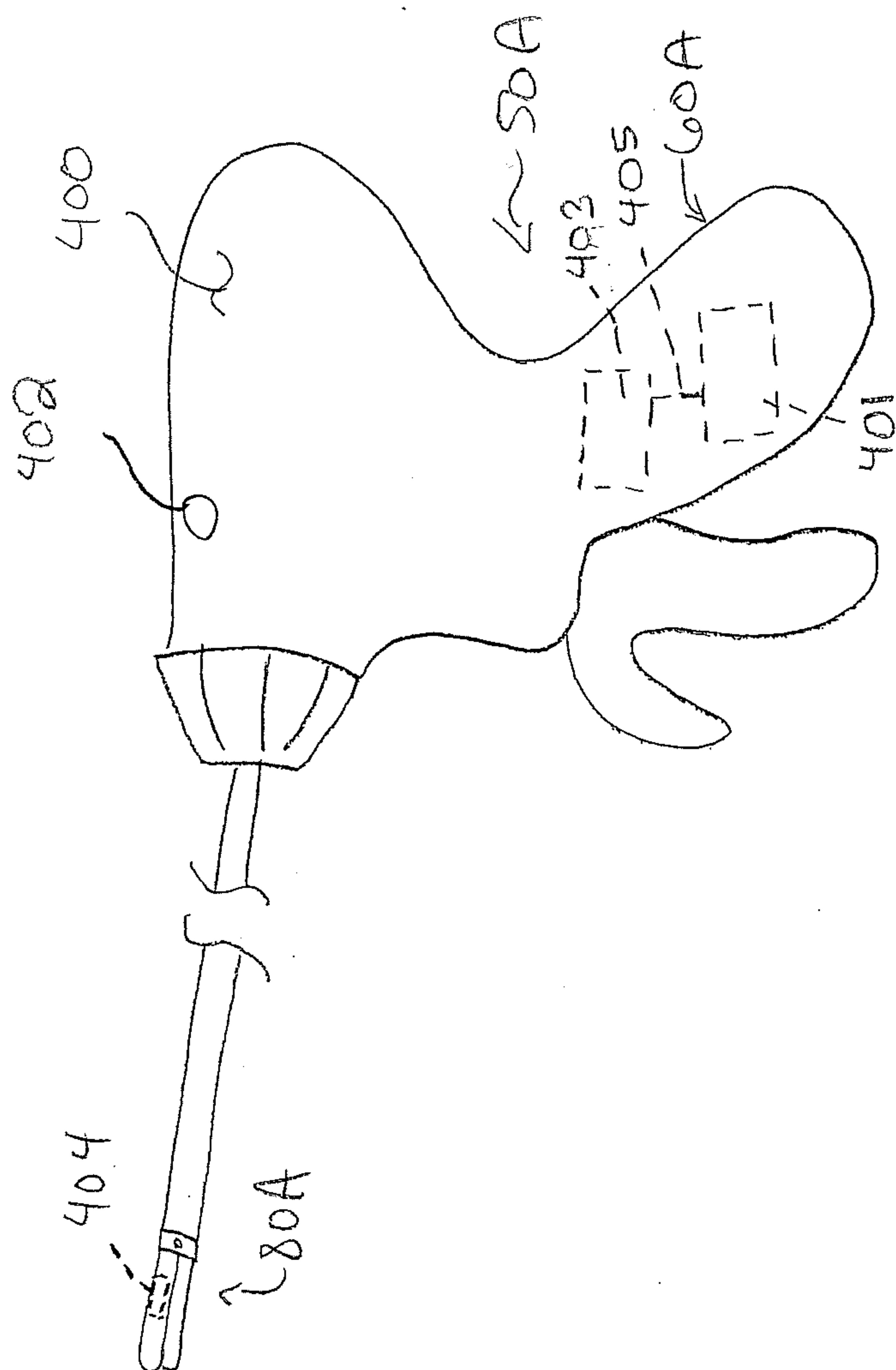

FIG. 3

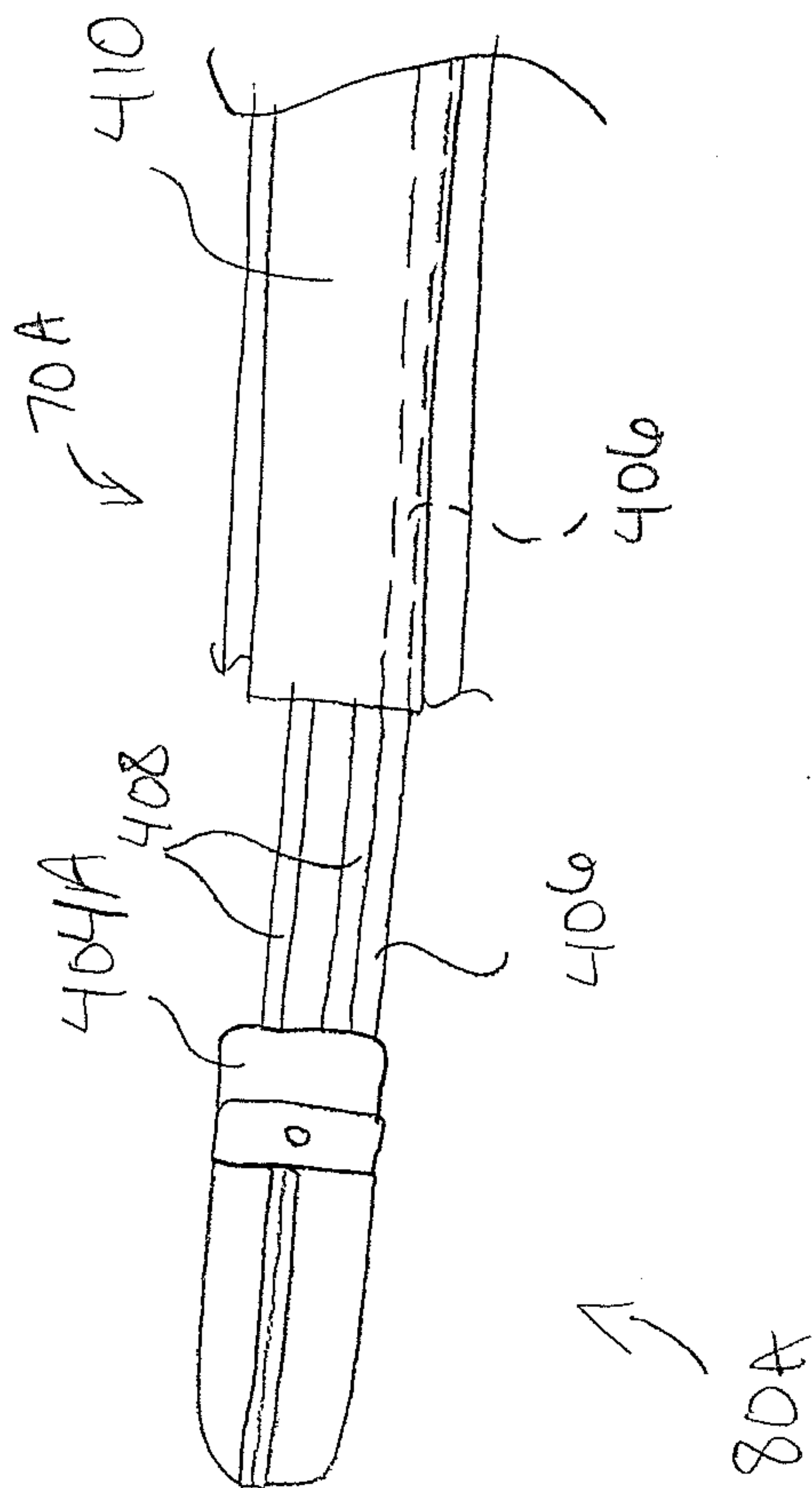

FIG. 4



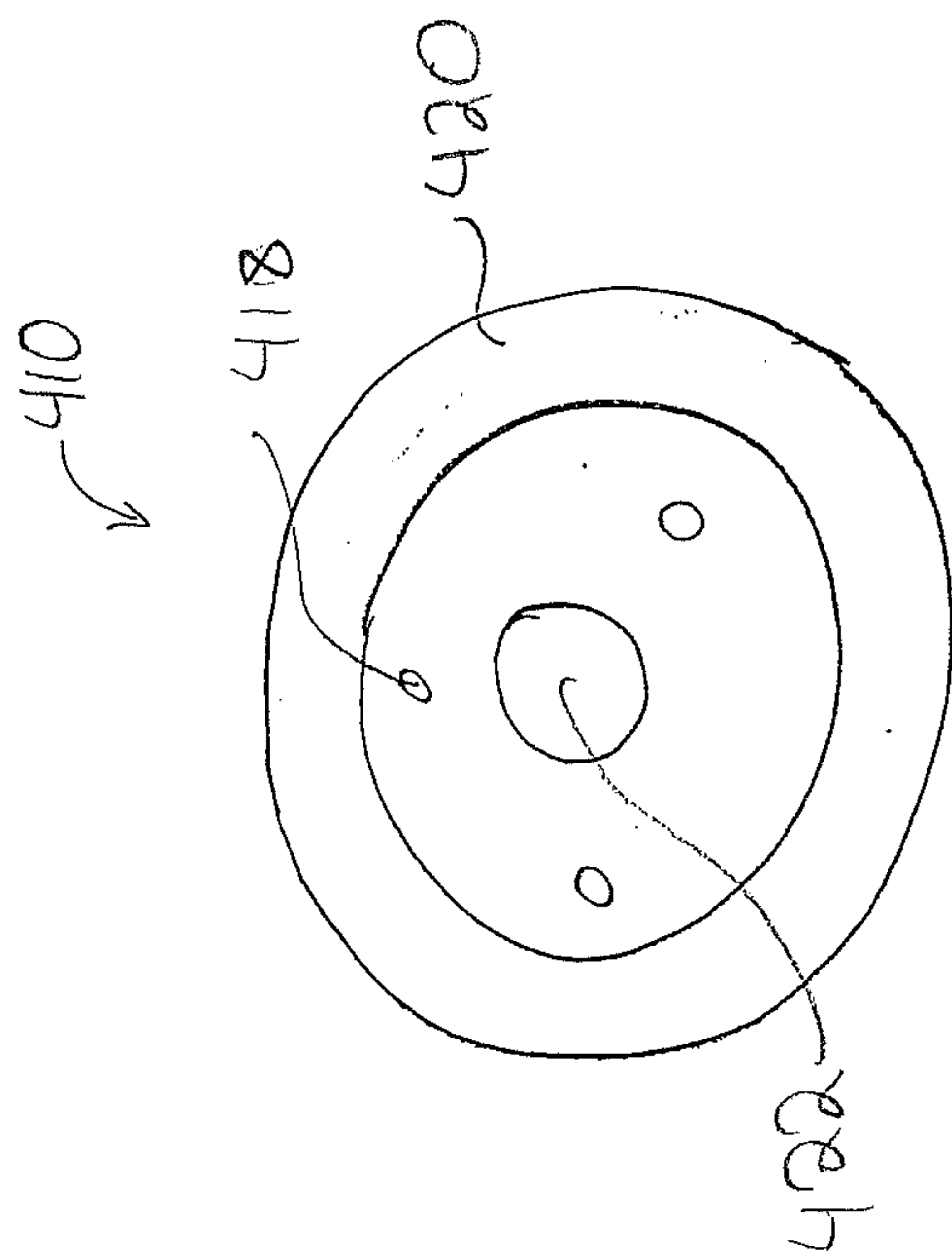

FIG. 6

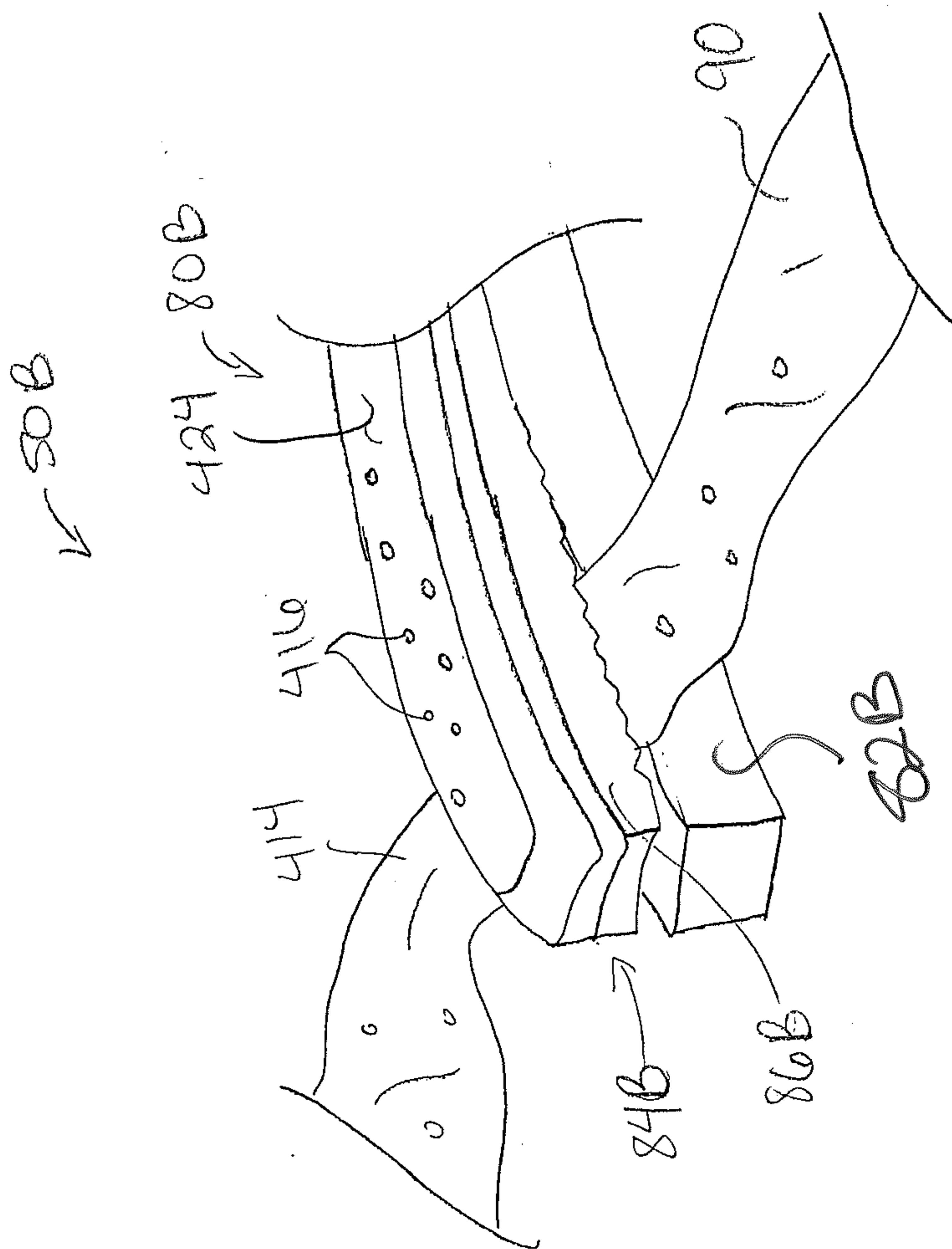

FIG. 17

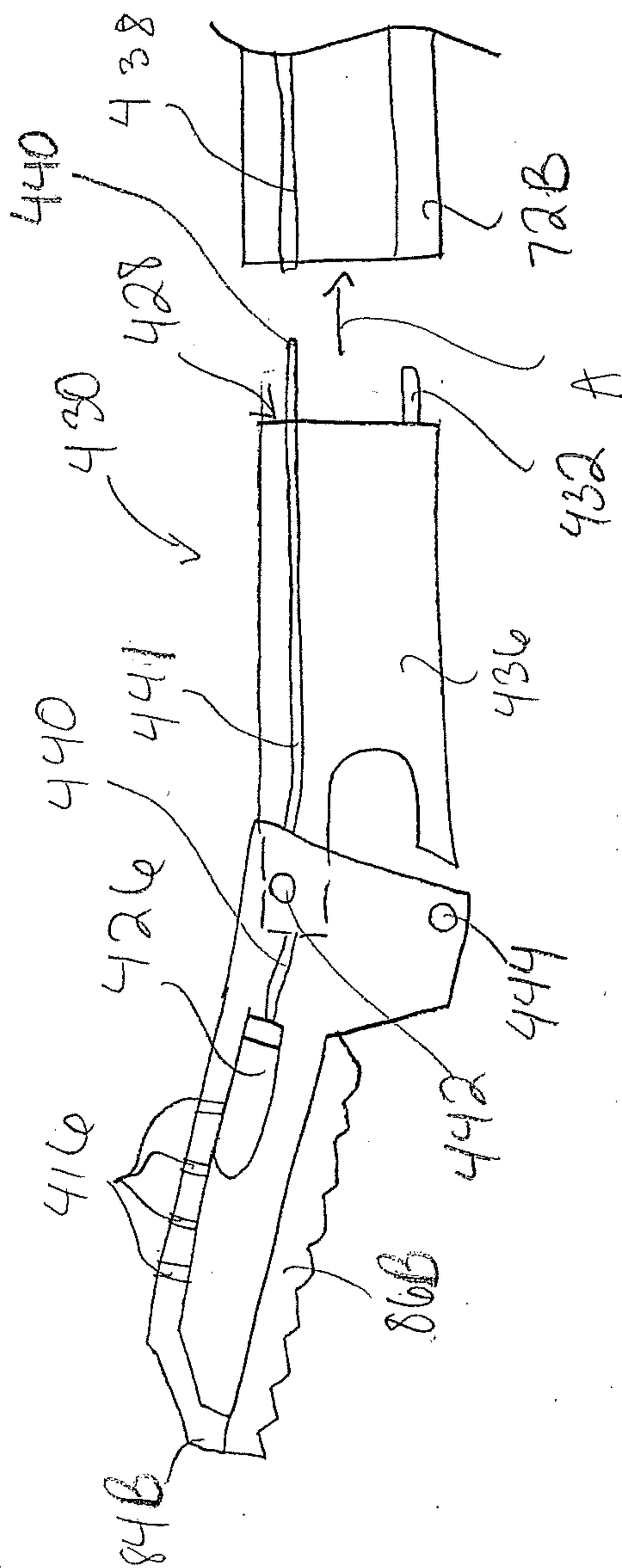

FIG. 8

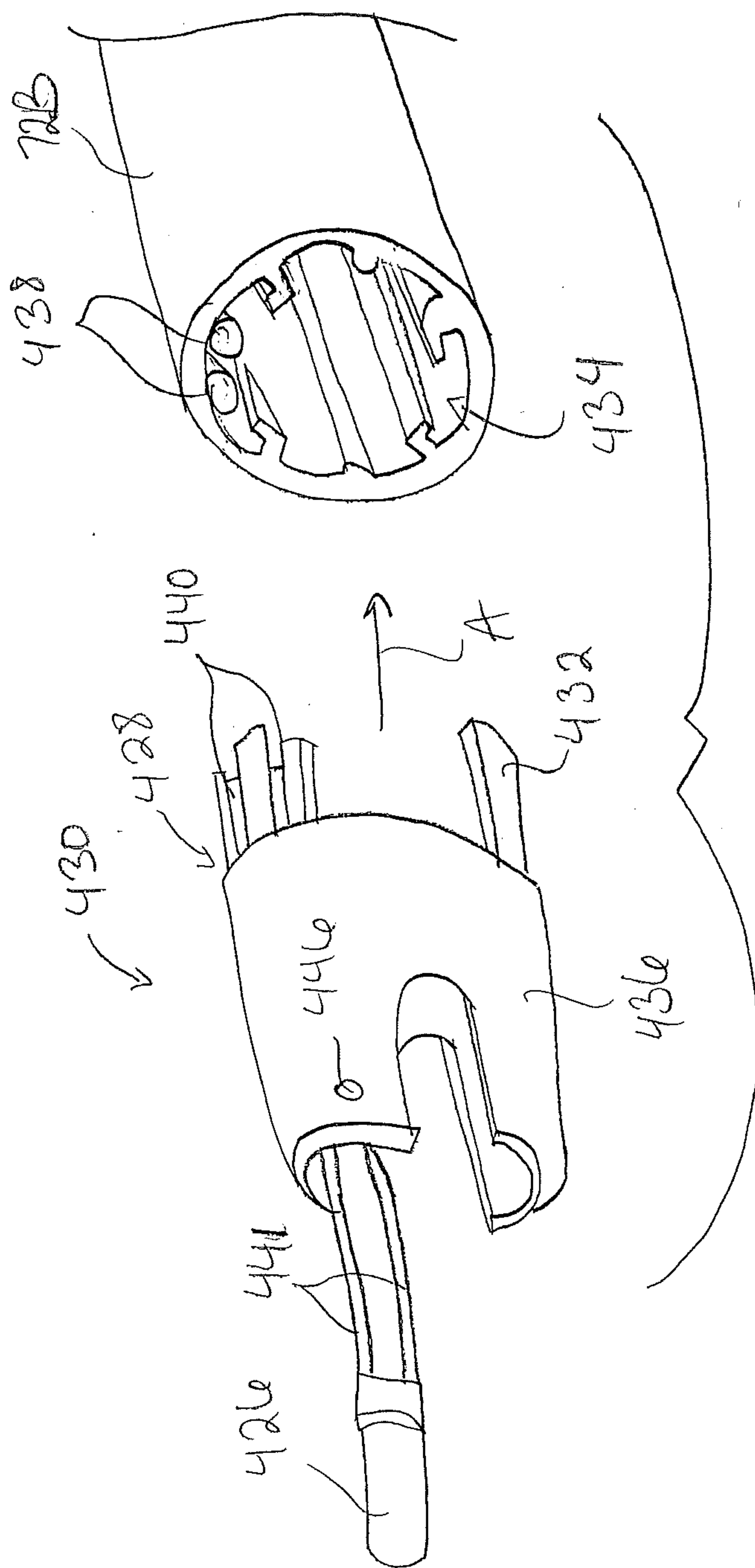

FIG. 9

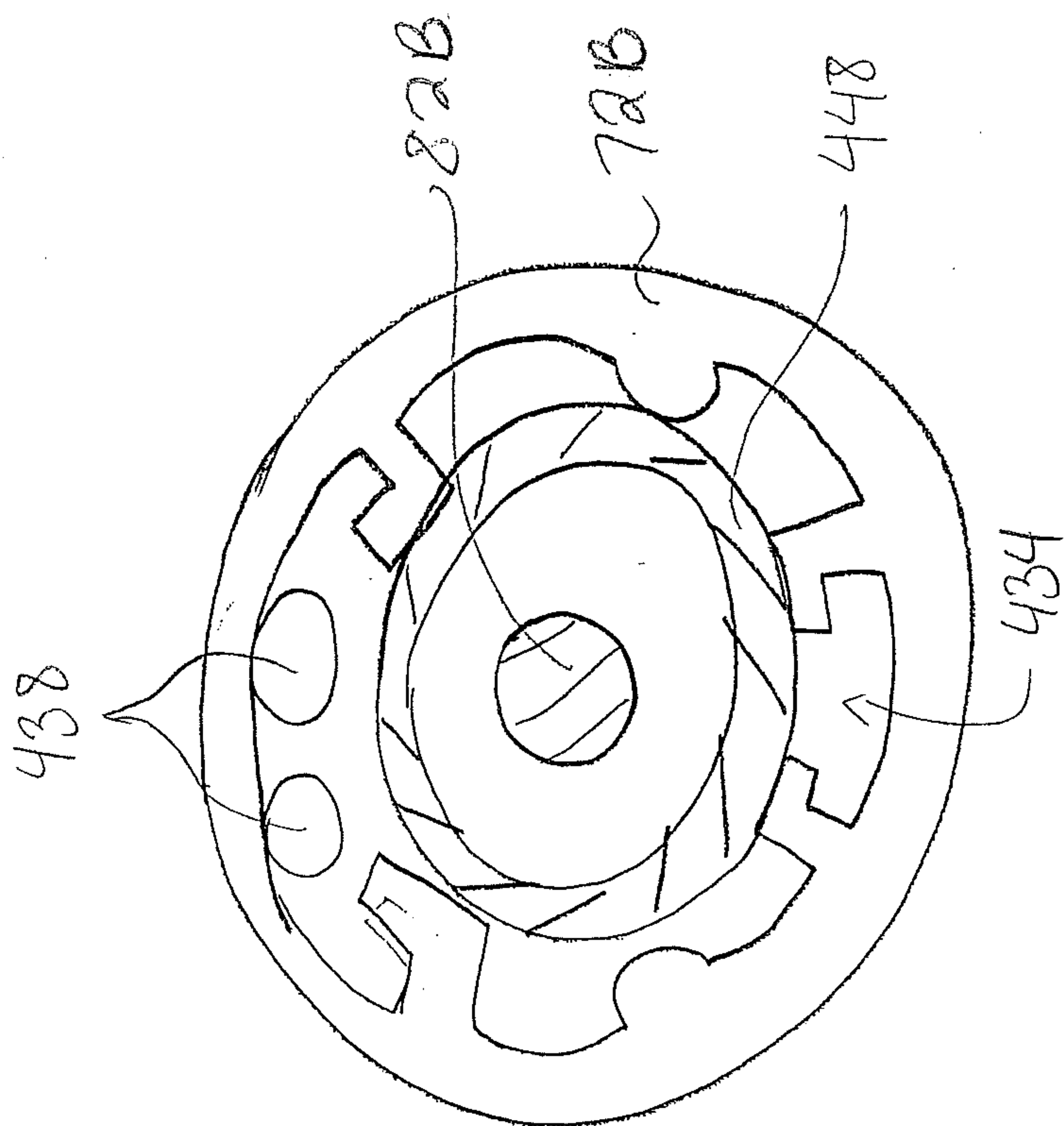
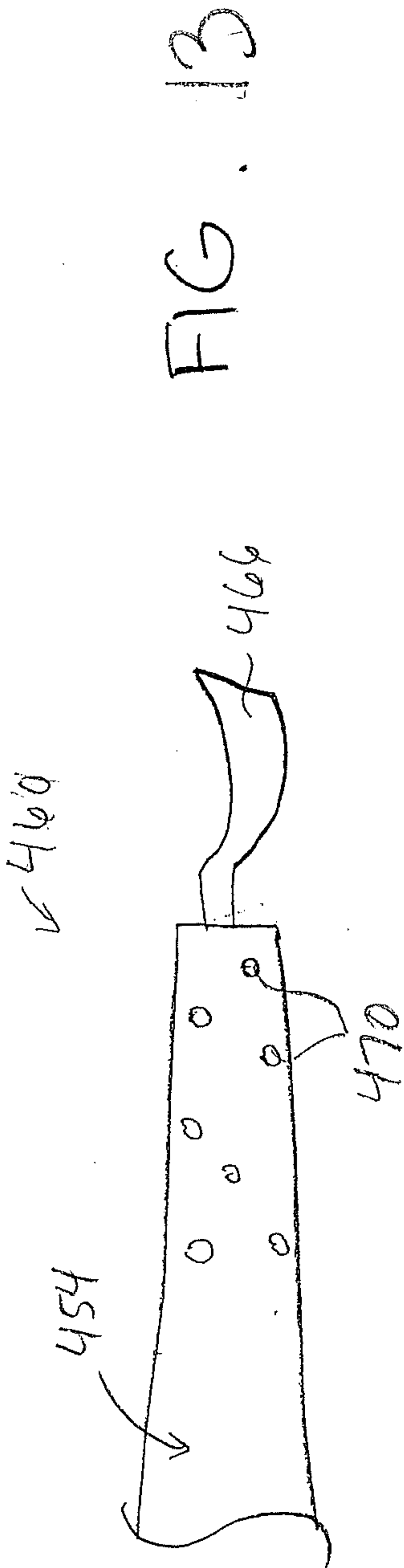
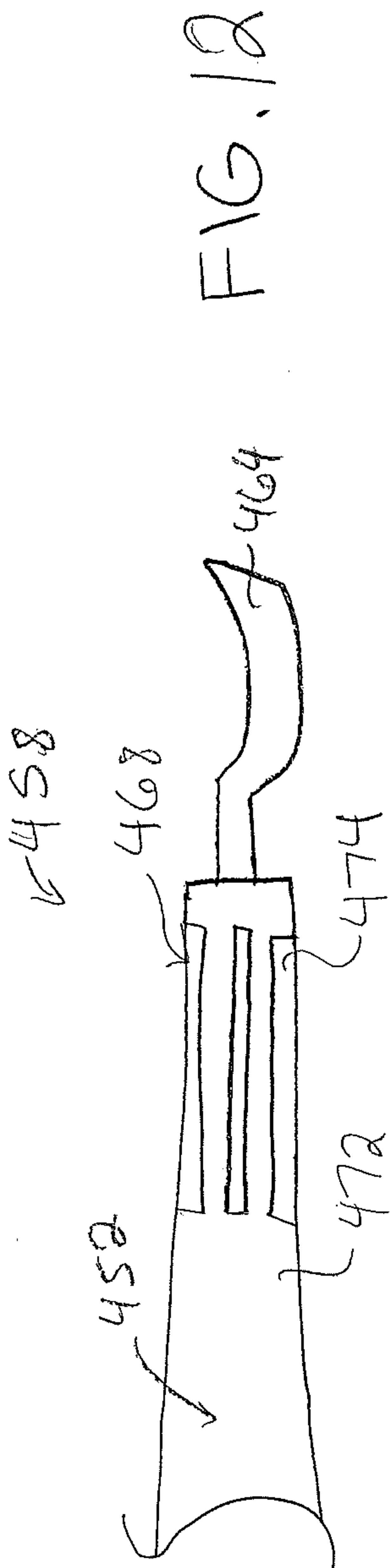
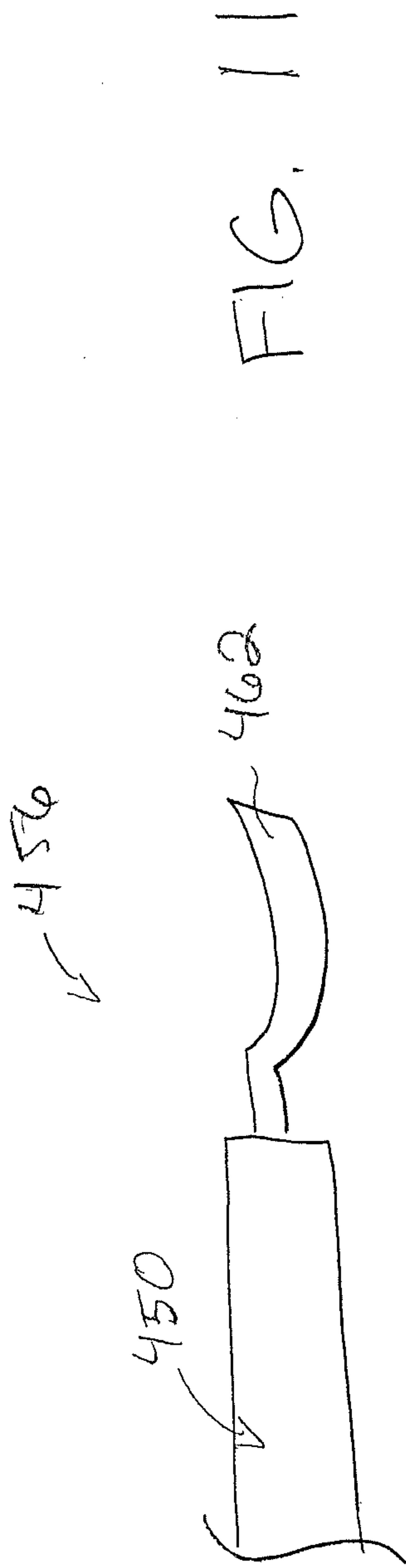
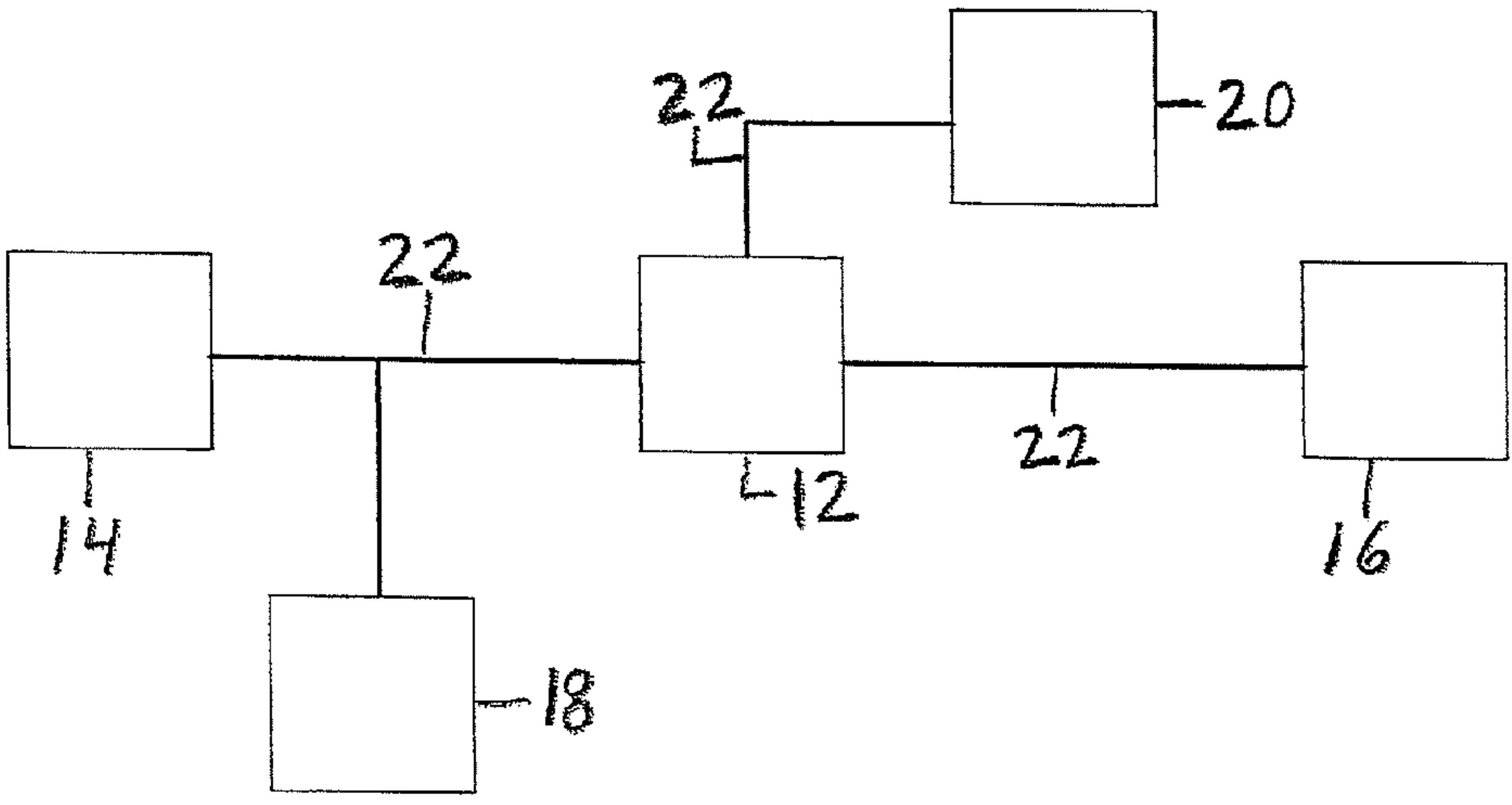

FIG. 10





10

FIG. 1