

(12) **United States Patent**
Lo et al.

(10) **Patent No.:** **US 10,149,173 B2**
(45) **Date of Patent:** **Dec. 4, 2018**

(54) **MULTIPLE-ANTENNA SYSTEM FOR CELL-SPECIFIC AND USER-SPECIFIC TRANSMISSION**

(71) Applicant: **Neocific, Inc.**, Bellevue, WA (US)

(72) Inventors: **Titus Lo**, Bellevue, WA (US);
Xiaodong Li, Kirkland, WA (US)

(73) Assignee: **Neocific, Inc.**, Bellevue, WA (US)

(*) Notice: Subject to any disclaimer, the term of this patent is extended or adjusted under 35 U.S.C. 154(b) by 376 days.

(21) Appl. No.: **15/155,975**

(22) Filed: **May 16, 2016**

(65) **Prior Publication Data**

US 2016/0262027 A1 Sep. 8, 2016

Related U.S. Application Data

(63) Continuation of application No. 14/725,254, filed on May 29, 2015, now Pat. No. 9,344,313, which is a continuation of application No. 13/668,102, filed on Nov. 2, 2012, now Pat. No. 9,048,540, which is a continuation of application No. 13/396,487, filed on (Continued)

(51) **Int. Cl.**

H04W 16/28 (2009.01)
H01Q 1/24 (2006.01)
H01Q 25/00 (2006.01)
H04L 5/00 (2006.01)
H04L 27/26 (2006.01)
H04W 56/00 (2009.01)
H04W 72/04 (2009.01)

(Continued)

(52) **U.S. Cl.**

CPC **H04W 16/28** (2013.01); **H01Q 1/246** (2013.01); **H01Q 25/00** (2013.01); **H04B 7/0617** (2013.01); **H04L 5/005** (2013.01); **H04L 27/2605** (2013.01); **H04W 56/001** (2013.01); **H04W 56/0005** (2013.01); **H04W 72/0453** (2013.01); **H04W 88/08** (2013.01)

(58) **Field of Classification Search**

CPC **H04W 16/28**
See application file for complete search history.

(56) **References Cited**

U.S. PATENT DOCUMENTS

6,005,515 A * 12/1999 Allen H01Q 3/40
342/368
6,167,286 A * 12/2000 Ward H01Q 1/246
455/132

(Continued)

Primary Examiner — Ankur Jain

(74) *Attorney, Agent, or Firm* — Perkins Coie LLP

(57) **ABSTRACT**

A reception method and apparatus for use in a multi-cell orthogonal frequency division multiple access (OFDMA) wireless system. In a unicast receive mode during a first receive time period, a first group of orthogonal frequency division multiplexing (OFDM) symbols is received by a mobile device from multiple of a plurality of antennas at a serving base station. In a single-frequency-network (SFN) receive mode during a second receive time period, a second group of OFDM symbols is received by the mobile device from one of a plurality of antennas at the serving base station. The transition between the first receive time period and the second receive time period occurs during a cyclic prefix or a cyclic postfix between OFDM symbols, and the plurality of antennas produce a first beam pattern during the unicast receive mode and a second beam pattern during the SFN receive mode.

11 Claims, 14 Drawing Sheets

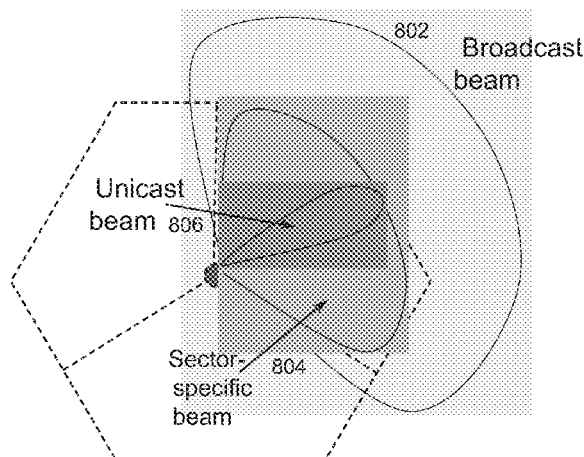

Related U.S. Application Data

Feb. 14, 2012, now Pat. No. 8,326,366, which is a continuation of application No. 13/276,240, filed on Oct. 18, 2011, now Pat. No. 8,116,822, which is a continuation of application No. 11/908,262, filed as application No. PCT/US2006/060888 on Nov. 14, 2006, now Pat. No. 8,041,395.

(60) Provisional application No. 60/736,500, filed on Nov. 14, 2005.

(51) **Int. Cl.**

H04B 7/06 (2006.01)

H04W 88/08 (2009.01)

(56) **References Cited**

U.S. PATENT DOCUMENTS

6,728,554 B1 *	4/2004	Wegner	H01Q 1/246 342/373
7,289,834 B2 *	10/2007	Sun	H04B 7/0848 455/137
8,041,395 B2 *	10/2011	Lo	H01Q 1/246 455/562.1

* cited by examiner

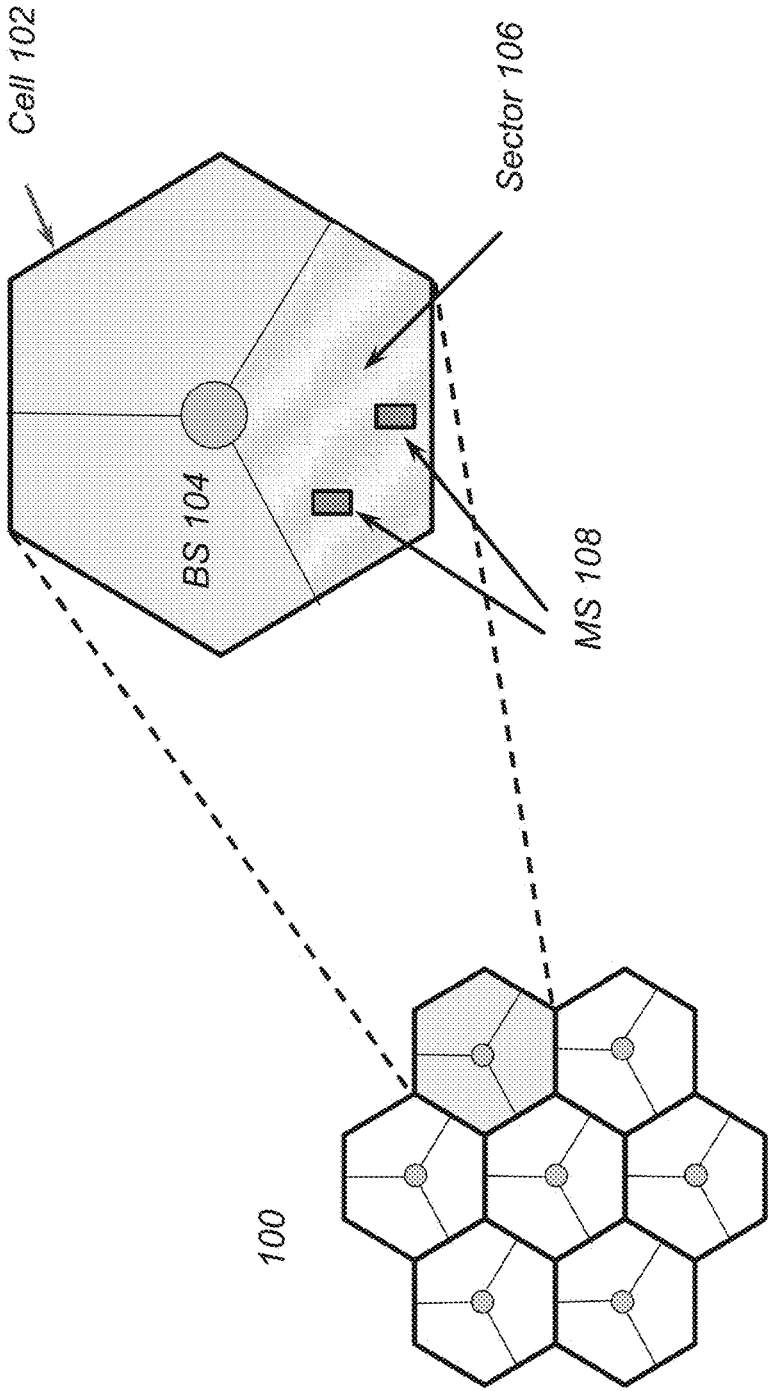

FIG. 1

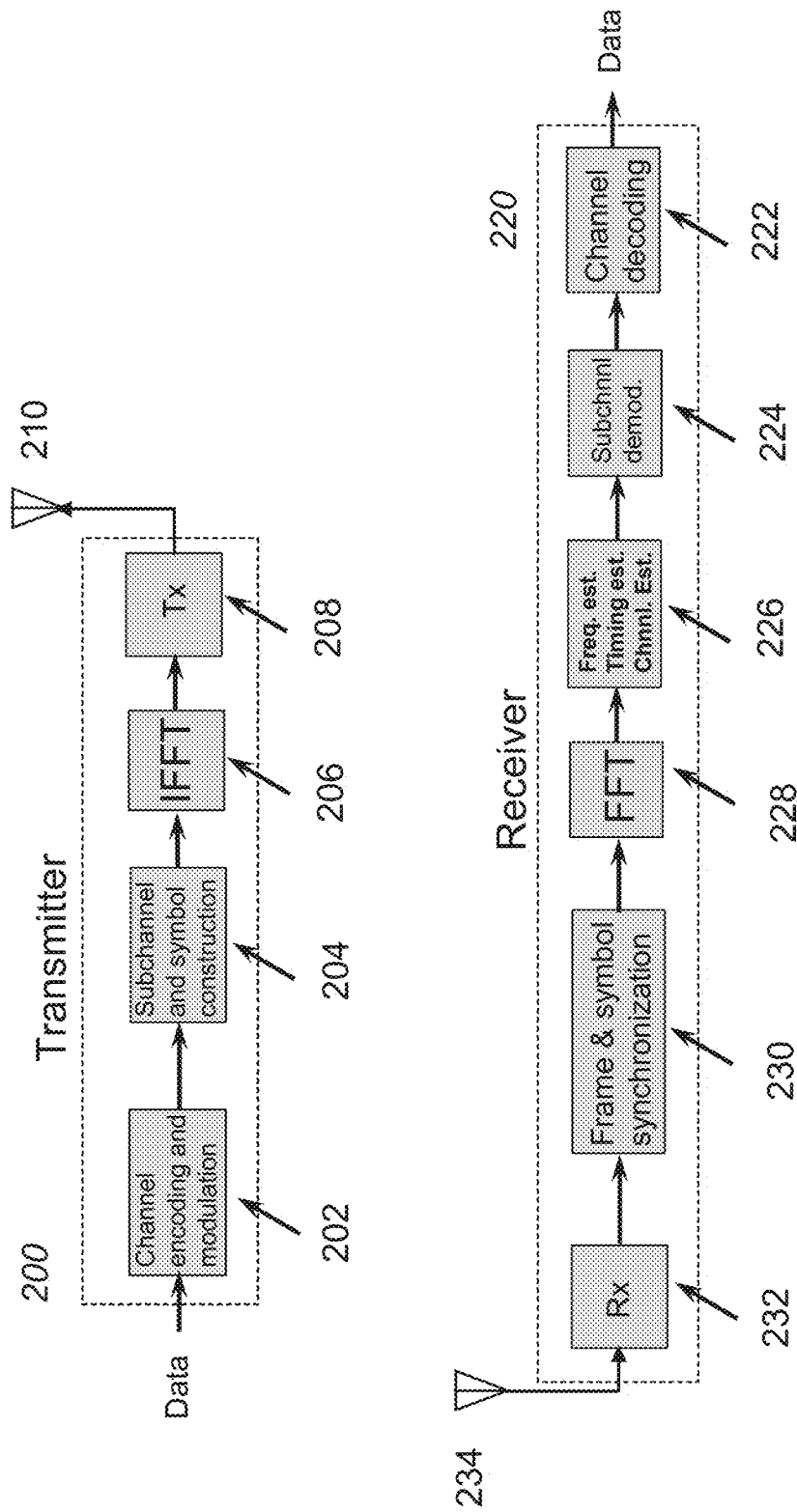

FIG. 2

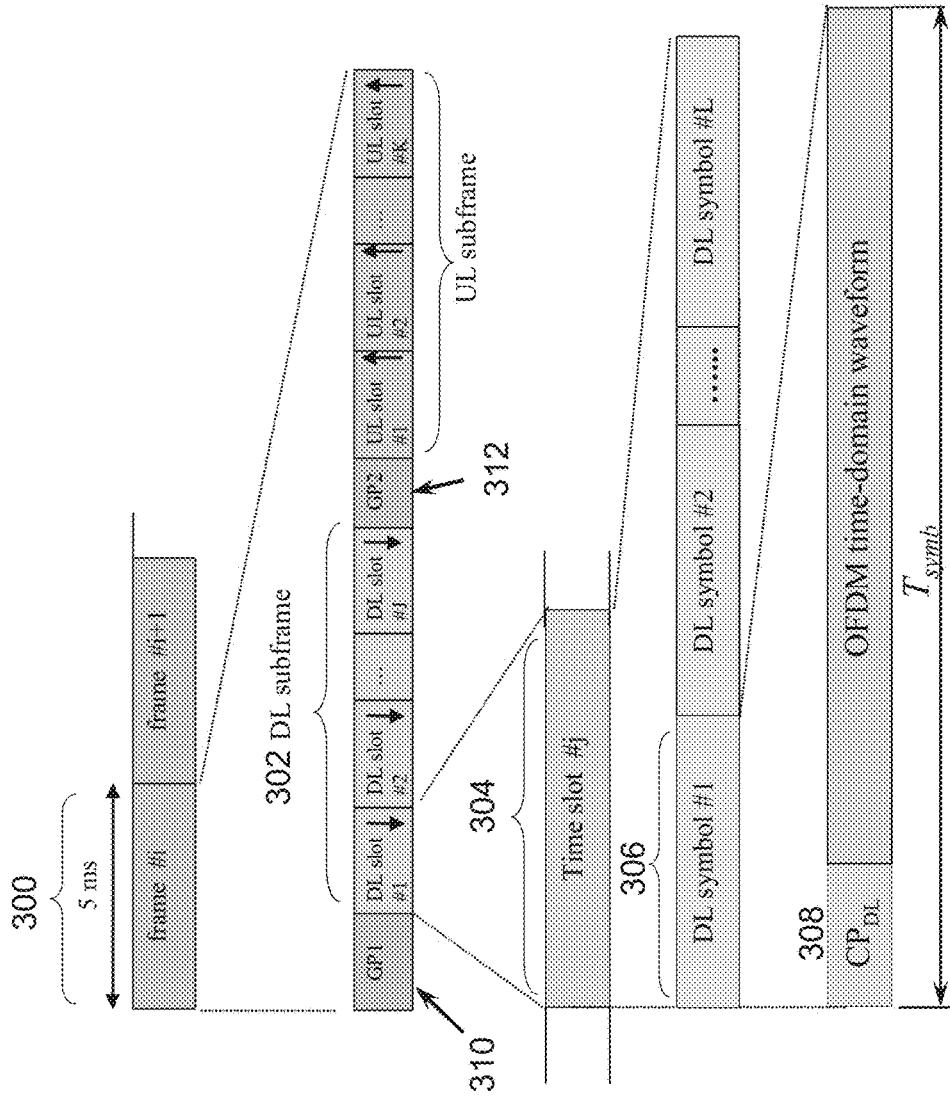

FIG. 3

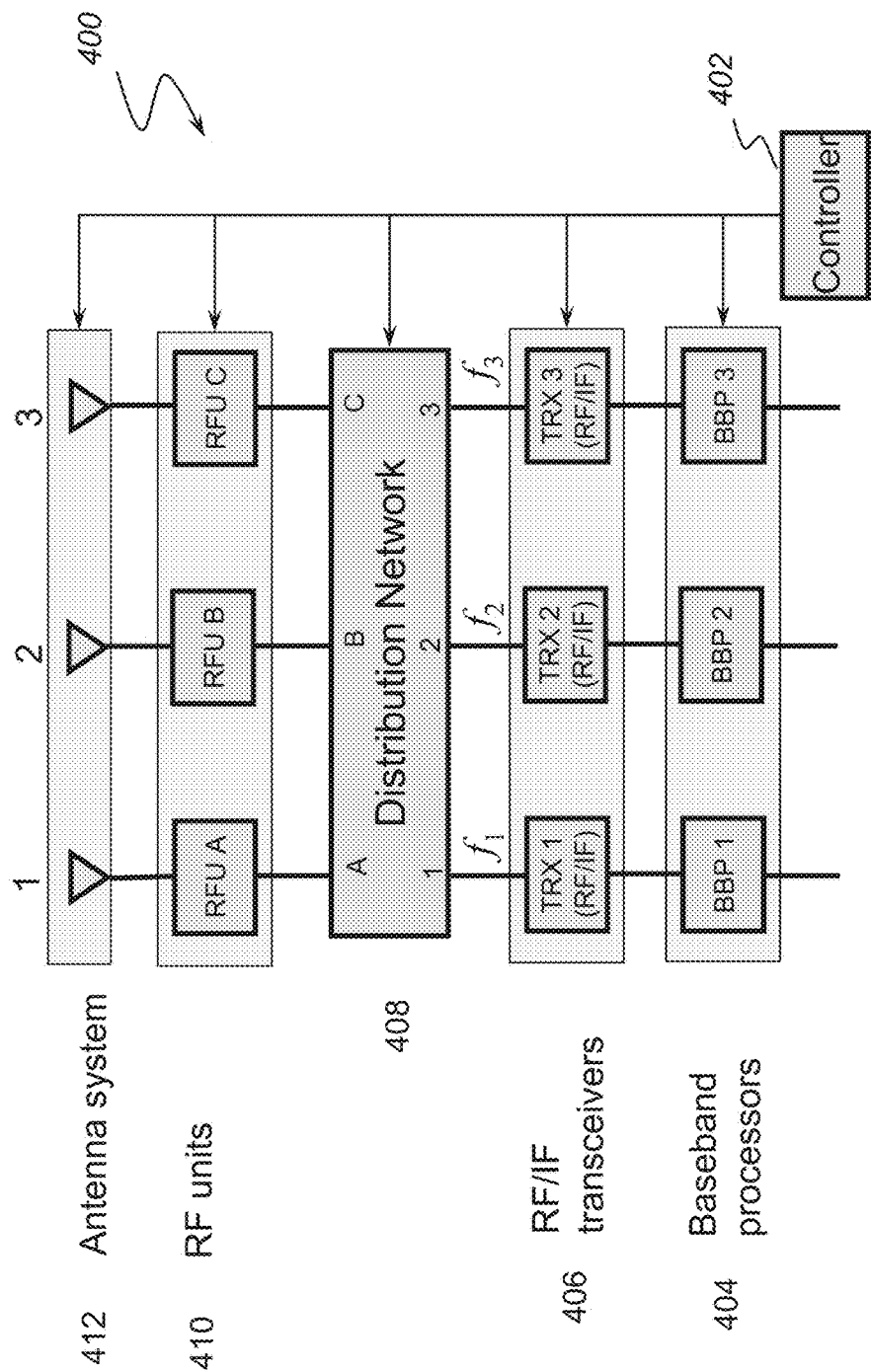

FIG. 4

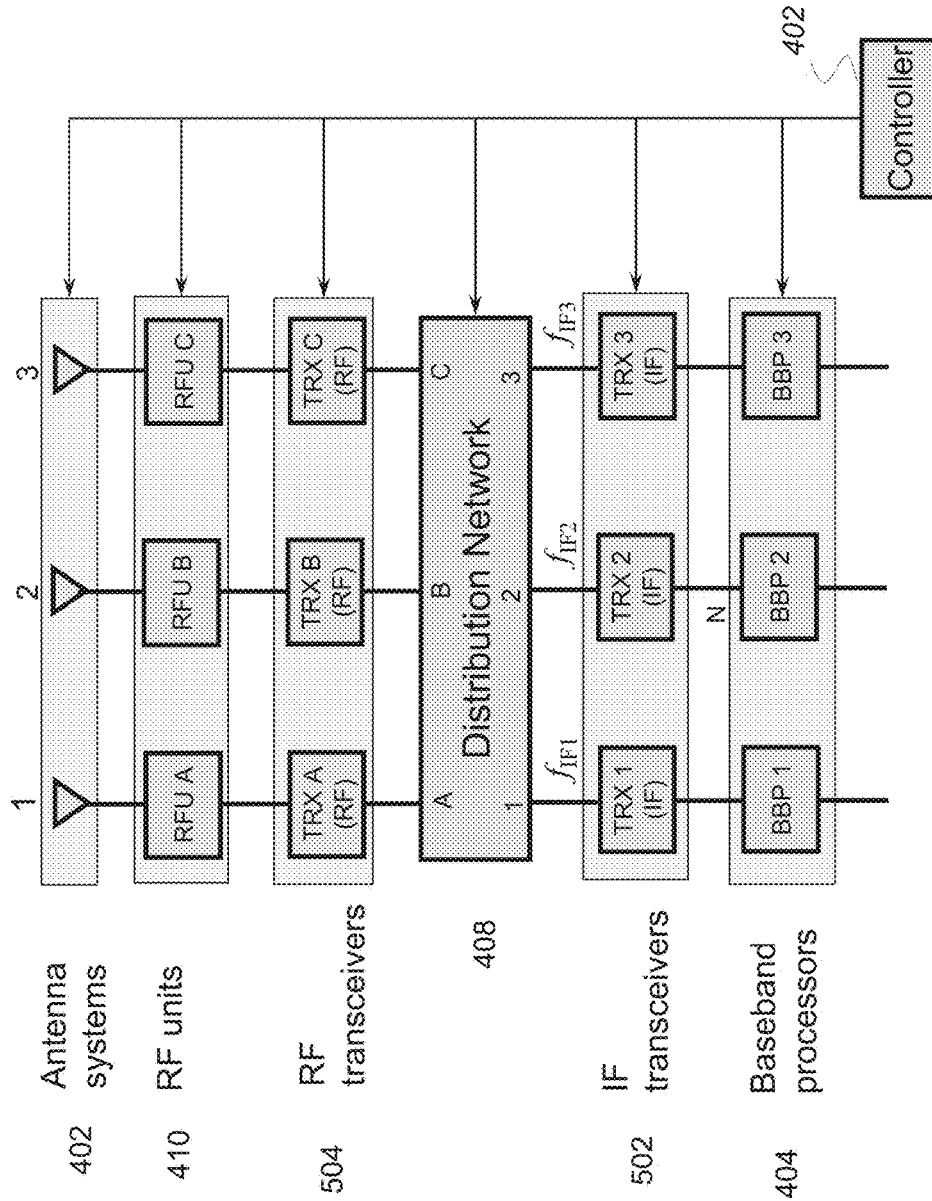

FIG. 5

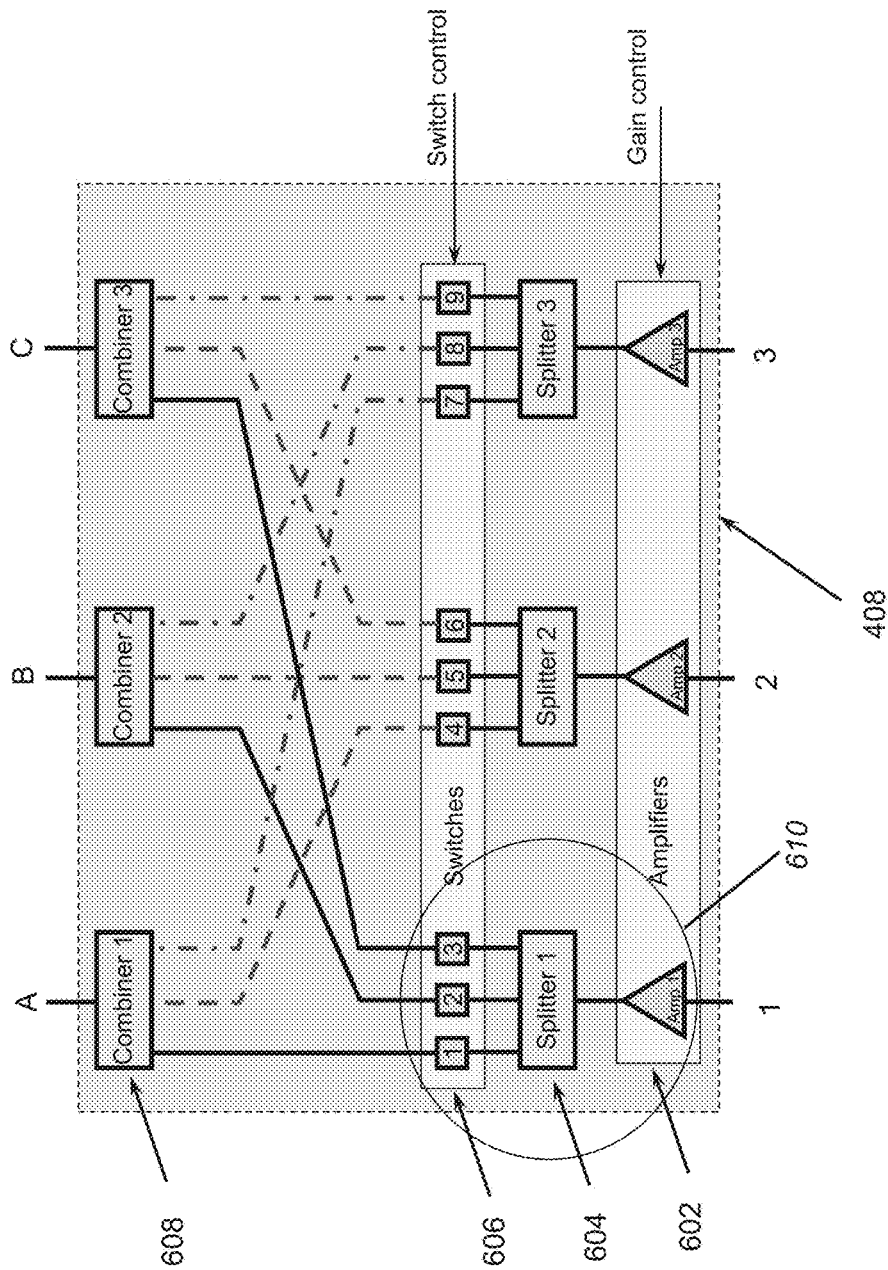

FIG. 6

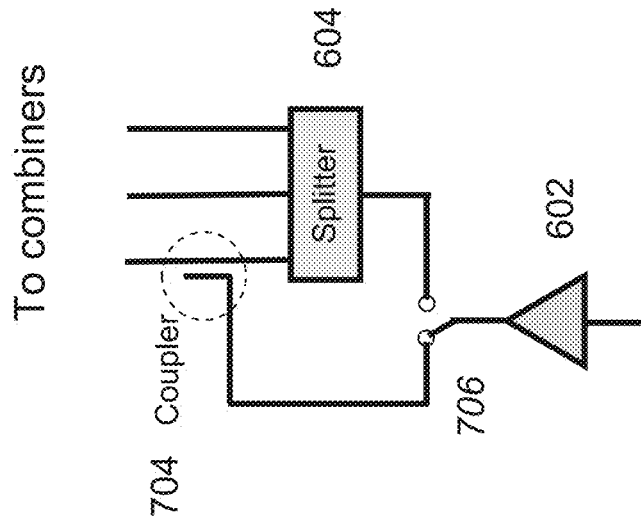

FIG. 7A

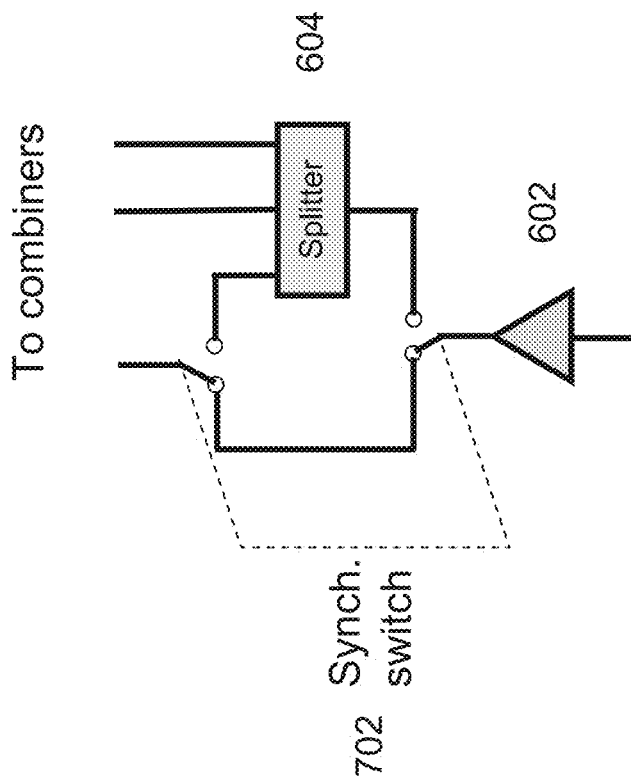

FIG. 7B

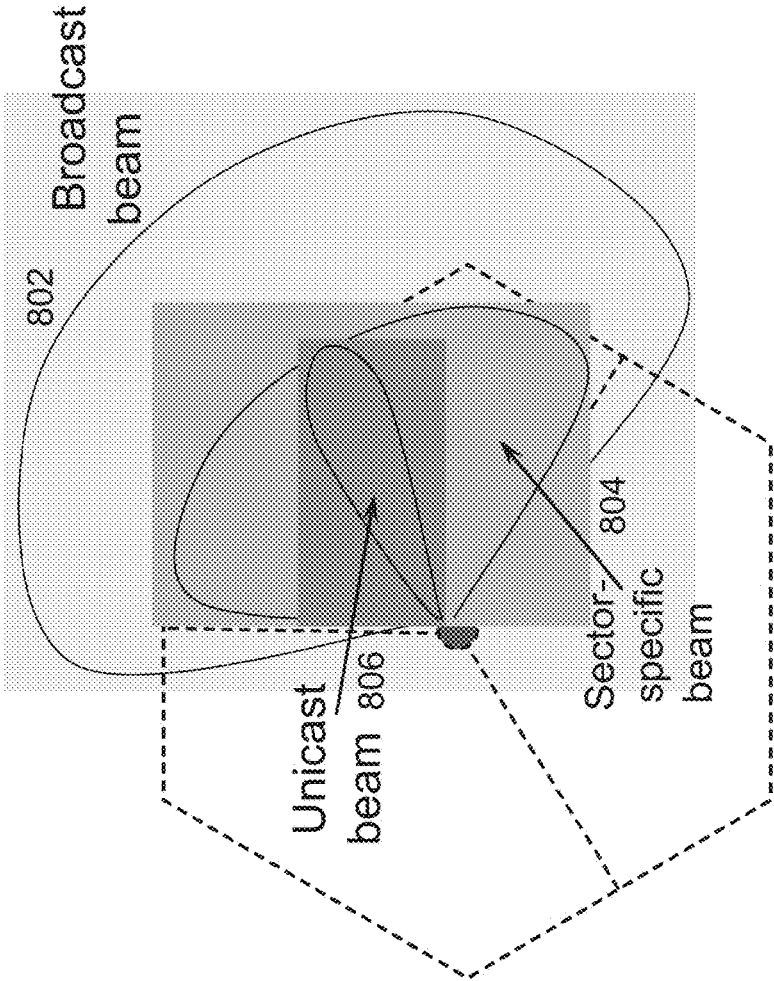

FIG. 8

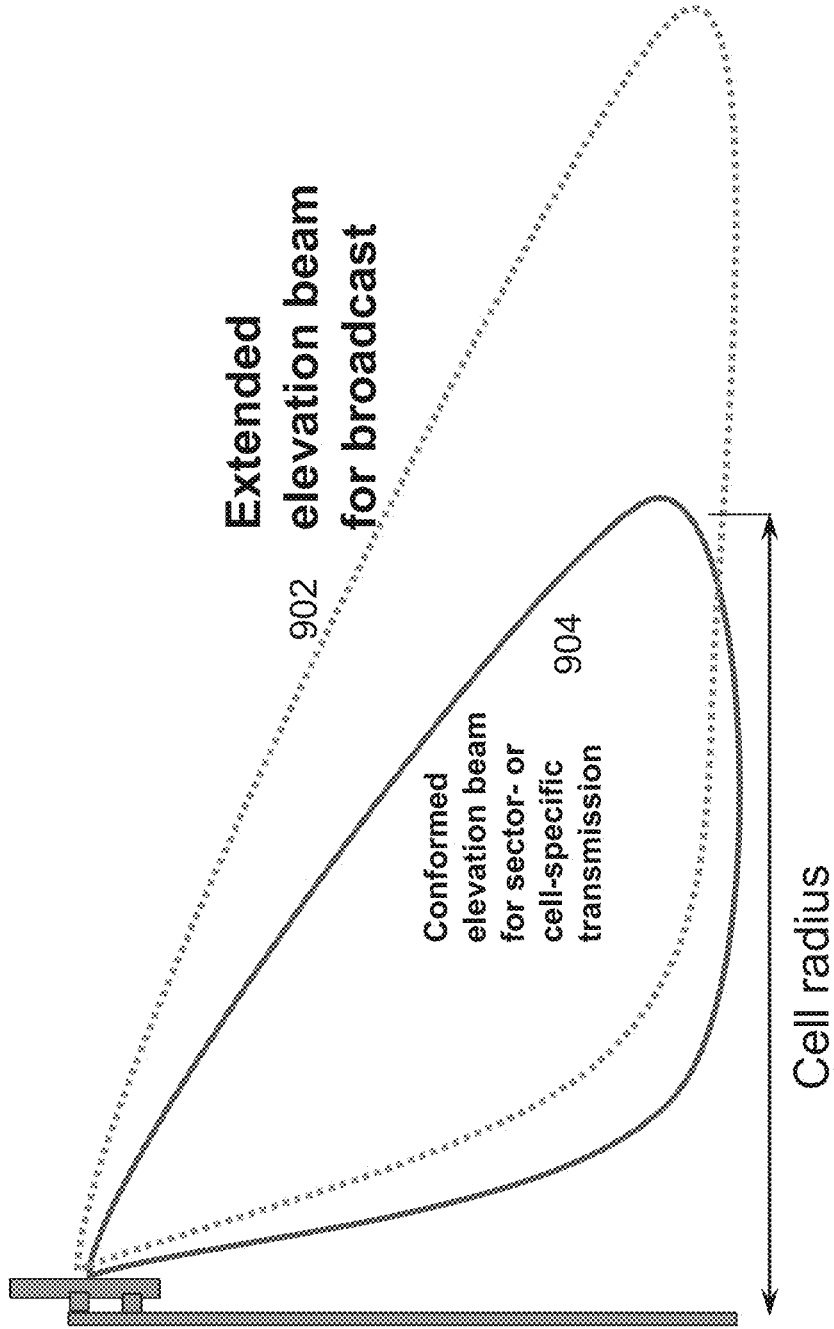
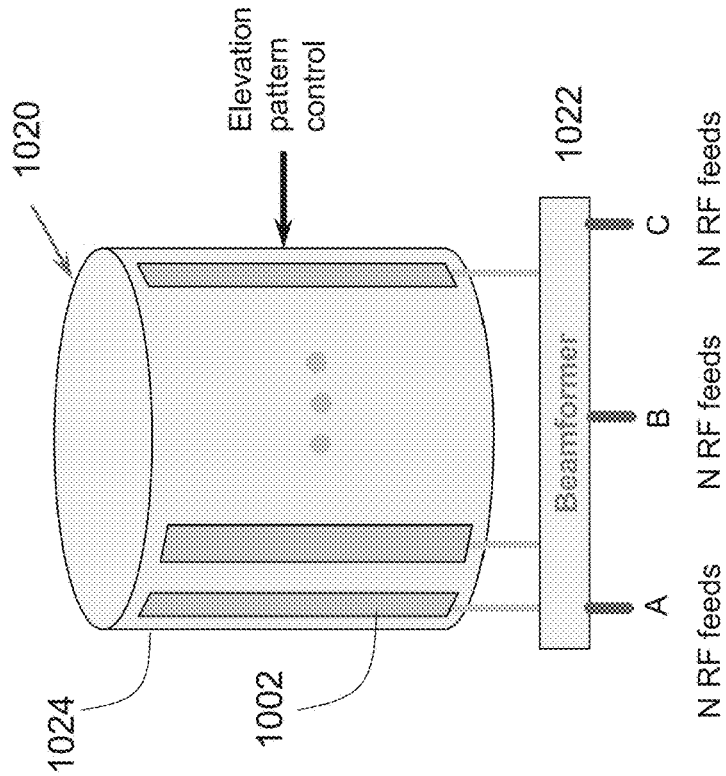
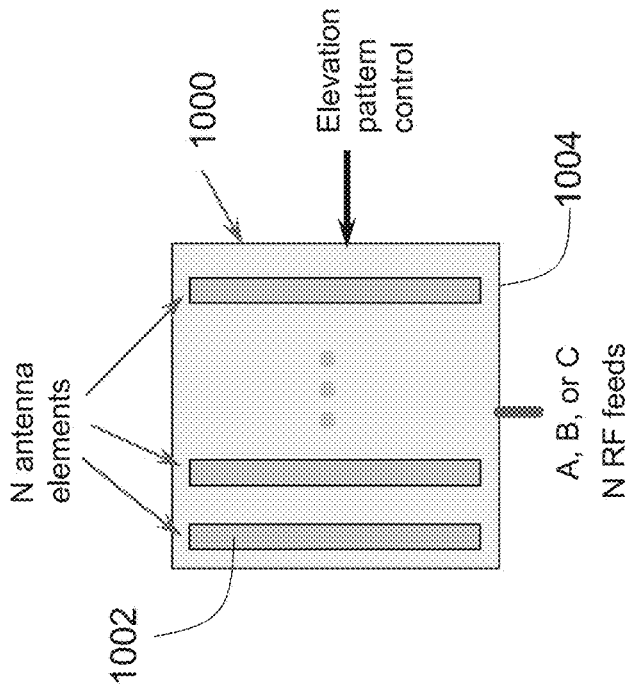

FIG. 9



A 3-dimensional antenna system (e.g., circular array), which can be used to provide coverage to all sectors of a cell.

FIG. 10B



A 2-dimensional antenna system, which can be used to provide coverage to a sector.

FIG. 10A

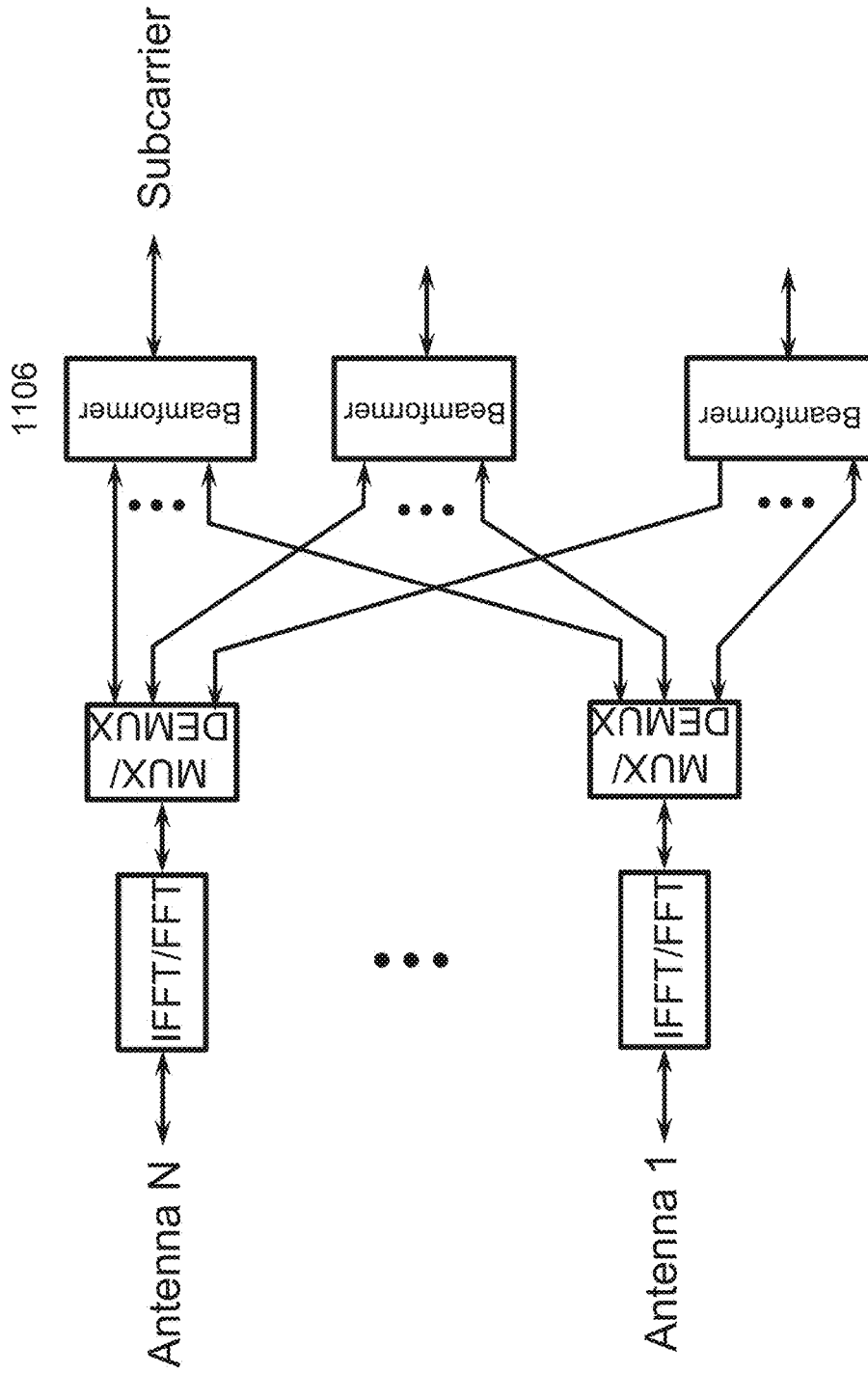

FIG. 11

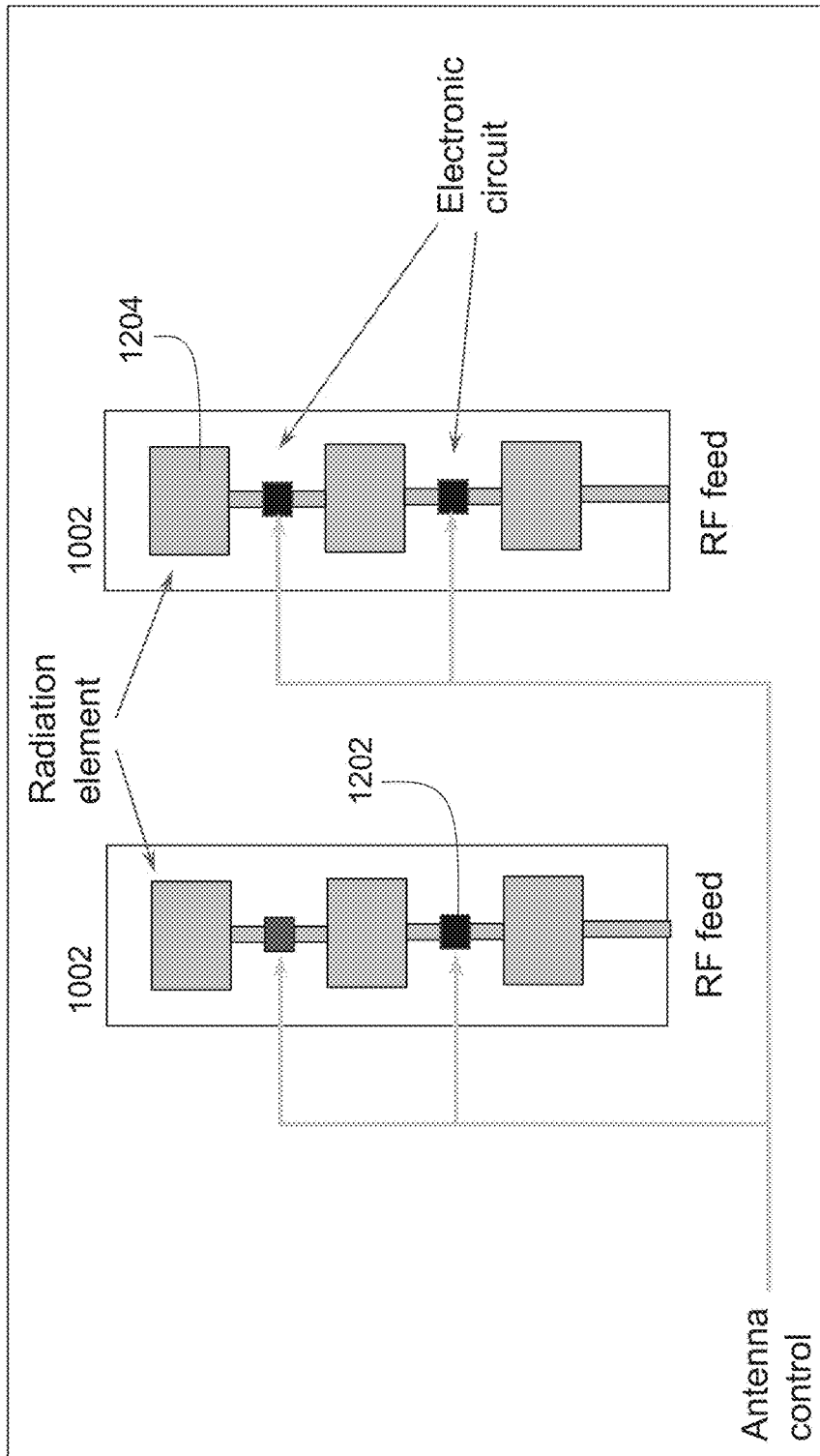

FIG. 12

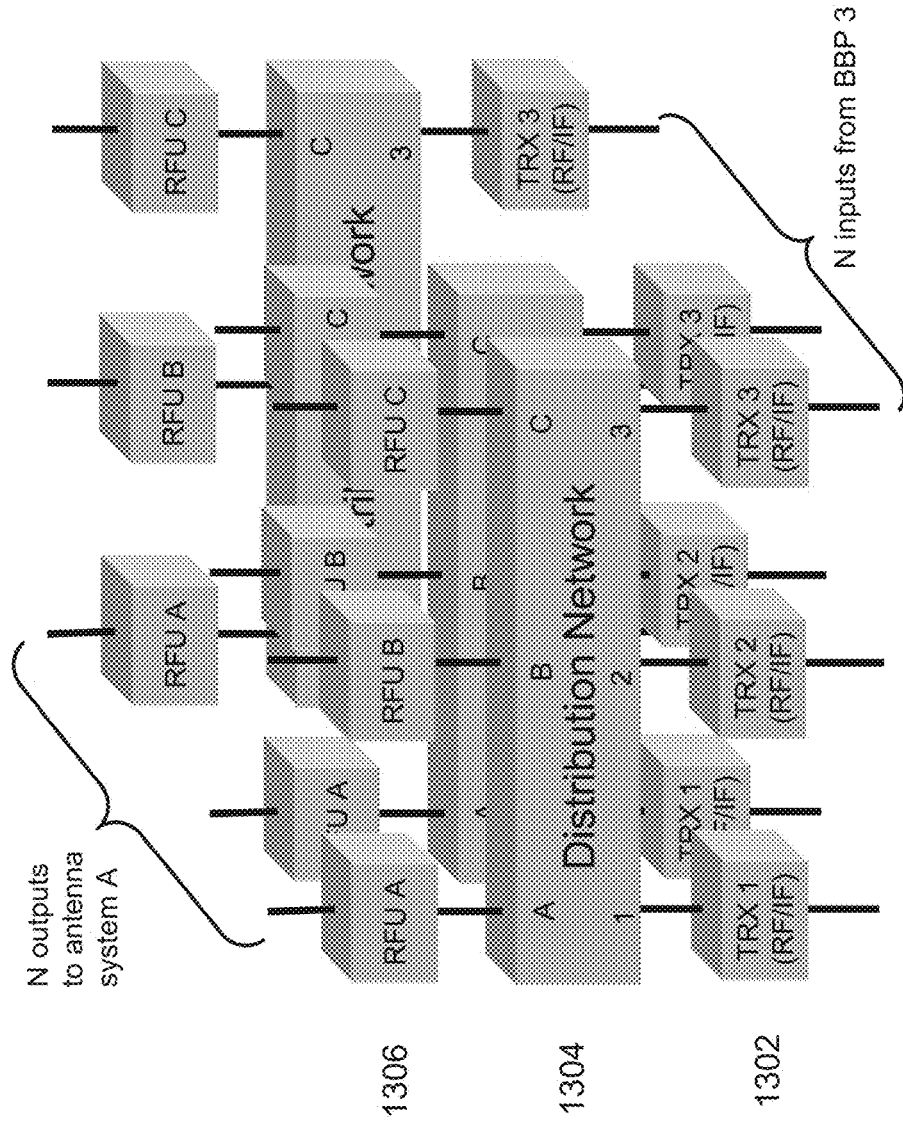

FIG. 13

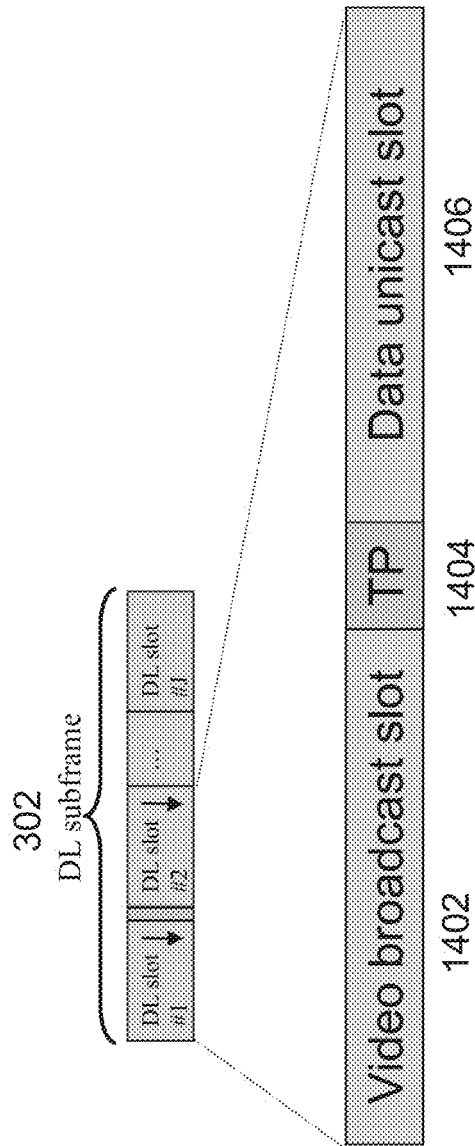

FIG. 14

1

MULTIPLE-ANTENNA SYSTEM FOR CELL-SPECIFIC AND USER-SPECIFIC TRANSMISSION

CROSS-REFERENCE TO RELATED APPLICATION(S)

This application is a continuation application of U.S. patent application Ser. No. 14/725,254 (now U.S. Pat. No. 9,344,313), filed May 29, 2015, which is a continuation application of U.S. patent application Ser. No. 13/668,102 (now U.S. Pat. No. 9,048,540), filed Nov. 2, 2012, which is a continuation application of U.S. patent application Ser. No. 13/396,487 (now U.S. Pat. No. 8,326,366), filed Feb. 14, 2012, which is a continuation application of U.S. patent application Ser. No. 13/276,240 (now U.S. Pat. No. 8,116,822), filed Oct. 18, 2011, which is a continuation application of U.S. patent application Ser. No. 11/908,262 (now U.S. Pat. No. 8,041,395), having a 371 date of Oct. 30, 2008, which is a national stage application of International Application No. PCT/US06/60888, filed Nov. 14, 2006, which claims the benefit of U.S. Provisional Patent Application No. 60/736,500, filed on Nov. 14, 2005. U.S. patent application Ser. Nos. 13/396,487, 13/276,240 and 11/908,262 are incorporated herein by reference in their entireties.

TECHNICAL FIELD

The disclosed embodiments relate, in general, to wireless communication and, in particular, to antenna systems for use in cellular communication and broadcasting.

BACKGROUND

An antenna system is an indispensable component of any wireless communication network. Wireless communications is presently available in many forms, among which the most common one is cellular/mobile communications.

In a cellular wireless network, the geographical region to be serviced by the network is normally divided into smaller areas called cells. Within each cell are mobile stations (MSs) that are used by users to access the network. A cell may be further divided into multiple sectors and in each sector the coverage is provided by a base station (BS). A BS also serves as a focal point to distribute information to and collect information from MSs that are located in the cell by radio signals that are transmitted by the BS antenna.

There are different types of transmissions carried out by BSs. A BS can send specific data to an individual MS within its sector; a BS may also send a set of common data to all the MSs within its sector; a BS may also send data via a common channel to all the MSs within a cell; and a group of BSs may broadcast information via a common channel simultaneously to all MSs within a group of cells. Depending on the type of transmission, a distinctive set of requirements may be required for the BS antenna system in terms of radiation patterns, power settings, etc. In addition, a frequency-reuse scheme may impose constraints on the antenna system. The extent to which an antenna system meets the wide range of requirements and constraints directly impacts on the wireless network performance. Therefore, there is a need to create an antenna system that is reconfigurable, adjustable, and controllable to enable a BS to carry out transmissions from a type of application to the other.

BRIEF DESCRIPTION OF THE DRAWINGS

FIG. 1 illustrates the coverage of a wireless communication network that is comprised of a plurality of cells.

2

FIG. 2 is a block diagram of a receiver and a transmitter, such as might be used in a multi-carrier wireless communication network.

FIG. 3 is a graphical depiction of a multi-carrier signal structure in the time domain.

FIG. 4 is a block diagram of a particular realization of a transmitter for cellular communication and broadcast.

FIG. 5 is a block diagram of a variant realization of a transmitter for cellular communication and broadcast.

FIG. 6 is a block diagram of a distribution network used in a transmitter for cellular communication and broadcast.

FIGS. 7A and 7B are block diagrams of alternate implementations of the distribution network.

FIG. 8 is a graphical depiction of using different types of antenna beams for different types of transmissions.

FIG. 9 is a graphical depiction of using a conformed elevation beam for unicast and sector-specific broadcast and an extended elevation beam for broadcast.

FIGS. 10A and 10B are perspective views of examples of antenna systems.

FIG. 11 is a block diagram of a beamforming process in an OFDMA system.

FIG. 12 is a perspective view of an antenna that generates different elevation beams.

FIG. 13 is a block diagram of a bank of N distribution networks used in beamforming, transmit-diversity, or MIMO applications.

FIG. 14 is a graphical depiction of inserting a transition period between a video broadcast slot and a data unicast slot.

DETAILED DESCRIPTION

A multiple-antenna system for cellular communication and broadcasting is disclosed. The multiple-antenna system can be controlled, adjusted, configured, or reconfigured to produce desirable radiation beam patterns suitable for different types of applications (e.g., voice, data, video, etc.). For example, the multiple-antenna system can be controlled to enable unicast transmissions with a specific reuse scheme or broadcast transmissions with one or more channels.

In some embodiments, a signal distribution network is provided in the multiple-antenna system. The signal distribution network is embedded in a transmitter at a base station (BS) and controls the distribution of signals to one or more antennas. Various antenna radiation patterns suitable for different applications can be generated by reconfiguring the connections and gain settings in the signal distribution network. By shaping the azimuth pattern of a beam and activating appropriate antenna elements to produce a predefined elevation pattern of a beam, different radiation beam patterns may be generated for use in different types of applications. For example, narrow beams may be generated for use in unicast applications, whereas sector beams may be generated for use in broadcast applications.

In some embodiments, certain techniques are employed to manage the transition from one type of transmission mode to another type of transmission mode. A transmission mode may correspond to a particular antenna beam pattern or to other settings for a particular application.

The following discussion contemplates the application of the disclosed technology to a multi-carrier system, such as Orthogonal Frequency Division Multiplexing (OFDM), Orthogonal Frequency Division Multiple Access (OFDMA), or Multi-Carrier Code Division Multiple Access (MC-CDMA). The invention can be applied to either Time Division Duplexing (TDD) or Frequency Division Duplex-

ing (FDD). Without loss of generality, OFDMA is therefore only used as an example to illustrate the present technology.

The following description provides specific details for a thorough understanding of, and enabling description for, various embodiments of the technology. One skilled in the art will understand that the technology may be practiced without these details. In some instances, well-known structures and functions have not been shown or described in detail to avoid unnecessarily obscuring the description of the embodiments of the technology. It is intended that the terminology used in the description presented below be interpreted in its broadest reasonable manner, even though it is being used in conjunction with a detailed description of certain embodiments of the technology. Although certain terms may be emphasized below, any terminology intended to be interpreted in any restricted manner will be overtly and specifically defined as such in this Detailed Description section.

I. Wireless Communication Network

FIG. 1 is a representative diagram of a wireless communication network **100** that services a geographic region. The geographic region is divided into a plurality of cells **102**, and wireless coverage is provided in each cell by a base station (BS) **104**. One or more mobile devices (MS) **108** may be fixed or may roam within the geographic region covered by the network. The mobile devices are used as an interface between users and the network. Each base station is connected to the backbone of the network, usually by a dedicated link. A base station serves as a focal point to transmit information to and receive information from the mobile devices within the cell that it serves by radio signals. Note that if a cell is divided into sectors **106**, from a system engineering point of view each sector can be considered as a cell. In this context, the terms “cell” and “sector” are interchangeable.

In a wireless communication system with base stations and mobile devices, the transmission from a base station to a mobile device is called a downlink (DL) and the transmission from a mobile device to a base station is called an uplink (UL). FIG. 2 is a block diagram of a representative transmitter **200** and receiver **220** that may be used in base stations and mobile devices to implement a wireless communication link. The transmitter comprises a channel encoding and modulation component **202**, which applies data bit randomization, forward error correction (FEC) encoding, interleaving, and modulation to an input data signal. The channel encoding and modulation component is coupled to a subchannel and symbol construction component **204**, an inverse fast Fourier transform (IFFT) component **206**, a radio transmitter component **208**, and an antenna **210**. Those skilled in the art will appreciate that these components construct and transmit a communication signal containing the data that is input to the transmitter **200**. Other forms of transmitter may, of course, be used depending on the requirements of the communication network.

The receiver **220** comprises an antenna **234**, a reception component **232**, a frame and synchronization component **230**, a fast Fourier transform component **228**, a frequency, timing, and channel estimation component **226**, a subchannel demodulation component **224**, and a channel decoding component **222**. The channel decoding component de-interleaves, decodes, and derandomizes a signal that is received by the receiver. The receiver recovers data from the signal and outputs the data for use by the mobile device or base station. Other forms of receiver may, of course, be used depending on the requirements of the communication network.

FIG. 3 depicts the basic structure of a multi-carrier signal in the time domain, which is generally made up of time frames **300**, subframes **302**, time slots **304**, and OFDM symbols **306**. A frame consists of a number of time slots, and each time slot is comprised of one or more OFDM symbols. The OFDM time domain waveform is generated by applying an inverse-fast-Fourier-transform (IFFT) to the OFDM signals in the frequency domain. A copy of the last portion of the time waveform, known as the cyclic prefix (CP) **308**, is inserted in the beginning of the waveform itself to form the OFDM symbol. In the case of TDD, guard periods (GP1 **310** and GP2 **312**), are inserted between an uplink (UL) subframe and a downlink (DL) subframe and between a DL subframe and a UL subframe to account for the time needed to turn on and off transmitters and receivers, as well as radio propagation delay.

II. Multiple-Antenna System for Cellular Communication and Broadcasting

In cellular communications, different types of transmission modes may be used for different types of applications. When a base station sends specific data to an individual mobile station within its sector, the transmission mode is referred to as unicast and when a base station sends the same data to all mobile stations within its sector or cell, the transmission mode is referred to as broadcast. The multiple-antenna system disclosed herein can be controlled, adjusted, configured, or reconfigured to produce desirable radiation patterns suitable for different types of applications, such as unicast transmissions with a specific reuse scheme or broadcast transmissions with one or more channels.

Although a cell divided into three sectors is used as an example herein, those skilled in the art will appreciate that a cell may be divided into an arbitrary number of sectors and that the disclosed technology is not limited by the number of sectors within a cell.

A Cellular Communication and Broadcasting Transmissions

FIG. 4 depicts a transmitter **400** at a base station for cellular communication and broadcasting. The transmitter may consist of the following subsystems:

1. baseband processors (BBPs) **404**, which process digital data, assembling or disassembling data payloads and formatting the data in accordance with certain protocols as was previously described with respect to FIG. 3;
2. intermediate frequency (IF) and radio frequency (RF) transceivers (TRXs) **406** that are coupled to the baseband processors **404** and which convert digital baseband signals from the baseband processors into analog signals for transmission;
3. a signal distribution network **408** coupled to the RF/IF transceivers **406**, the signal distribution network receiving signals from the RF/IF transceivers and splitting and/or combining the signals in accordance with the requirements of particular applications being served by the transmitter;
4. RF units (RFUs) **410** that are coupled to the signal distribution network **408**, the RF units amplifying the signals to a certain power level for transmission; and
5. a multiple-antenna system **412** that is coupled to the RF units **410**, the multiple-antenna system transmitting the signals with various beam patterns (sectorial, omnidirectional, etc.) in accordance with a transmission mode that is selected based on the frequency reuse scheme and the type of application. The multiple-antenna system depicted in FIG. 4 consists of three sector-antennas, the radiation pattern of each sector-antenna which is fan-shaped. Alternatively, the system may consist of an omni-directional antenna, the radia-

tion pattern of which is omni-directional in azimuth. In some embodiments, the system may consist of both omni-directional antennas and sector antennas in a particular combination. For example, antenna **1** in the multiple-antenna system **412** may be an omni-directional antenna and antennas **2** and **3** may be sector antennas.

Those skilled in the art will appreciate that the subsystems in the transmitter **400** may be constructed with appropriate components and devices, such as switches, amplifiers, and/or couplers. The subsystems in the transmitter are controlled by a controller **402**, which is coupled to each of the subsystems.

While the distribution network **408** is depicted between the RF/IF transceivers **406** and RF units **410** in FIG. **4**, those skilled in the art will appreciate that the distribution network can be placed at various other points in the transmitter **400**. For example, the distribution network can be placed between the antenna system **412** and RF units **410**. Alternatively, as depicted in FIG. **5**, if the functionality of the RF/IF transceivers **406** is split into IF transceivers **502** and RF transceivers **504**, the distribution network **408** can be placed between the IF and RF transceivers. In the reuse-3 case (that is, each cell is split into three sectors and each sector uses a different frequency band for communication), f_1 , f_2 , and f_3 in FIG. **4** denote the three bands in RF or f_{IF1} , f_{IF2} , and f_{IF3} in FIG. **5** denote the three bands in IF. In the reuse-1 case, f_1 , f_2 , and f_3 represent the same RF channel or f_{IF1} , f_{IF2} , and f_{IF3} represent the same IF channel.

The signal distribution network **408**, which consists of amplifiers, splitters, switches, and combiners, is used to distribute and adjust signals so as to realize different settings or configurations required by various transmission modes to accommodate different applications. FIG. **6** depicts a typical implementation of the distribution network **408**. Three signal paths through the distribution network are depicted, with three inputs (**1**, **2**, and **3**) to the distribution network and three outputs (A, B, and C) from the distribution network. Those skilled in the art will appreciate that the number of inputs to and outputs from the distribution network can be varied depending on the desired transmission modes to be implemented. The gain on each path is controlled via a corresponding amplifier **602**. The output from each amplifier is coupled to a splitter **604**, which splits the output from the amplifier into multiple signals. Each output from the splitter **604** is coupled to a switch **606**, which may be a simple ON-OFF control device. The output from each switch is coupled to a combiner **608**. The splitters **604** perform the function of splitting (or fanning out) the input signal and the combiners **608** perform the function of combining the input signals. In some embodiments, the combiners may add the signals and operate over a broad range of frequencies. By selectively controlling the gain of amplifiers **602** and the state of switches **606**, the signals on outputs (A, B, and C) may be any combination of the signals received on inputs (**1**, **2**, **3**). Additional filtering or signal conditioning (not shown) may be implemented in the signal distribution network as well.

Those skilled in the art will appreciate that other configurations of components can be used to achieve the same functionality as is implemented by distribution network **408**. For example, the combination of an amplifier, a splitter, and switches identified by reference numeral **610** in FIG. **6** can be replaced by one of the variations shown in FIGS. **7A** and **7B**. In FIG. **7A**, switches **606** are replaced by a switch **700** that either directly connects the amplifier **602** to the combiner, or connects the amplifier to the splitter **604**. In FIG.

7B, switches **606** are replaced by a coupler **704** and a switch **706** that allows the amplifier **602** to be directly connected to the combiner, or connected to the splitter **604**.

Various types of transmissions can be carried out by controlling the amplification provided by the amplifiers and the state of the switches. For example, to enable unicast transmission, switches **1**, **5**, and **9** are turned on and switches **2**, **3**, **4**, **6**, **7**, and **8** are turned off. When the switches are in this state, the signals received on inputs (**1**, **2**, **3**) of the distribution network are directly coupled to the outputs (A, B, C) of the distribution network. Referring to FIG. **4**, if the signal flow for a sector **1** transmission were to be followed, the signals would flow from the baseband processor BBP1 through the distribution network to RFU A and antenna **1**.

To enable broadcast transmission using only one channel but three sector antennas, only the switches connected to a particular splitter (for example, switches **1**, **2**, and **3**) are turned on and the rest of the switches (in this example, **4**, **5**, **6**, **7**, **8**, and **9**) are turned off. Signals generated by a particular BBP (BBP1) are thereby transmitted via all three antennas while other BBPs (BBP2 and BBP3) are not transmitted.

To enable broadcast transmission using two channels but three sector antennas, only the switches connected to a particular splitter (for example, switches **7**, **8**, and **9**) are turned off and the rest of the switches (in this example, **1**, **2**, **3**, **4**, **5**, and **6**) are turned on. Signals generated by the two BBPs (BBP1 and BBP2) are thereby transmitted via all three antennas while the other BBP (BBP3) is not transmitted.

Turning on all switches enables broadcast transmission using three channels and three sector antennas. That is, signals generated by any BBP are transmitted via all three sector antennas. Some typical examples of transmission modes are listed in Table 1 with their corresponding switch states. A configuration index is provided in Table 1 to distinguish the different transmission modes and enable quick look-up of configuration information as will be described in additional detail below.

TABLE 1

Schemes of frequency reuse and types of transmission and their corresponding configuration index and settings					
Configuration Index	Frequency reuse and type of transmission	ON	OFF	Gain settings	Elevation beam
		switches	switches		
1	Unicast	1, 5, 9	2, 3, 4, 6, 7, 8	Amp 1 = x1 Amp 2 = y1 Amp 3 = z1	Conformed
2	Broadcast using one channel	1, 2, 3	4, 5, 6, 7, 8, 9	Amp 1 = x2 Amp 2 = y2 Amp 3 = z2	Extended
3	Broadcast using two channels	1, 2, 3, 4, 5, 6	7, 8, 9	Amp 1 = x3 Amp 2 = y3 Amp 3 = z3	Extended
4	Broadcast using all channels	1, 2, 3, 4, 5, 6, 7, 8, 9	N/A	Amp 1 = x4 Amp 2 = y4 Amp 3 = z4	Extended

While Table 1 represents many of the most common transmission modes, other combinations of the switch states can be employed to enable transmissions for specific applications. For example, with switches **1**, **2**, **4**, **5**, and **9** on and the rest of the switches off, signals generated by BBP1 and BBP2 are transmitted using two channels in both Sector **1** and Sector **2**, whereas signals generated by BBP3 are only transmitted in its own corresponding sector (i.e., Sector **3**).

The number of transmission modes is only limited by the construction of the signal distribution network and antennas.

The switch configuration necessary to achieve a desired transmission mode may also depend, in part, on the types of antennas used in the multi-antenna system **412**. For example, if antenna **1** in the multiple-antenna system **412** is an omni-directional antenna and antennas **2** and **3** are sector antennas, a broadcast transmission mode can be enabled using only the omni-directional antenna. With switch **1** turned on, signals from BBP**1** (one channel) are transmitted through antenna **1**. With switches **1** and **4** turned on, signals from both BBP**1** and BBP**2** (two channels) are transmitted through antenna **1**. With switches **1**, **4**, and **7** turned on, signals from all BBPs (three channels) are transmitted through antenna **1**.

In other embodiments, the gain setting on each path is set according to a specific scheme of frequency reuse and a specific type of transmission by the adjustable amplifier. B Controllable Beam Patterns for Cellular Communication and Broadcasting

By shaping the azimuth beam patterns and activating a predefined elevation beam pattern, different radiation beam patterns are generated by the antennas for transmissions in different types of applications. For example, FIG. **8** depicts the radiation beam pattern of a cell sector antenna as viewed from overhead. As depicted in FIG. **8**, a narrow beam **806** in azimuth is used for unicast; a sector-specific beam **804** is used for broadcast transmissions within the cell; and a broadcast beam **806** is used for multi-cell broadcast transmissions. FIG. **9** depicts the radiation beam pattern of a cell sector antenna as viewed in elevation. As shown in FIG. **9**, an elevation beam **904** that is conformed within a cell boundary is used for unicast and sector-specific broadcast, whereas an elevation beam **902** that extends beyond the cell boundary is used for multi-cell broadcast.

FIGS. **10A** and **10B** are each examples of an antenna system **412** that are controllable in azimuth and elevation, and are suitable for operating in different transmission modes in cellular communication and broadcasting. The antennas depicted in FIGS. **10A** and **10B** possess the following attributes:

1. the antenna consists of a plurality of antenna elements that can be controlled individually or collectively; and
2. the azimuth pattern and elevation pattern of the antenna can be shaped independently.

The antenna system depicted in FIG. **10A** is a 2-dimensional antenna systems **1000**, meaning that the antenna elements **1002** are mounted in an array on a substrate **1004** that orients the antenna elements in roughly a plane. One or more antenna systems **1000** may be mounted in a desired configuration in order to transmit within a particular region. For example, six of the antenna systems may be deployed in a regular hexagon shape in order to provide 360 degrees of coverage to a cell. In contrast, the antenna system depicted in FIG. **10B** is a 3-dimensional antenna system **1020**, meaning that the array of antenna elements **1002** are mounted on a substrate that orients the antenna elements in various directions. The substrate **1024** in FIG. **10B** is a cylindrical substrate, creating an antenna capable of generating a 360 degree radiation pattern.

The azimuth beam pattern and the elevation beam patterns of the antenna systems in FIGS. **10A** and **10B** may be shaped in a variety of ways. With respect to the azimuth pattern, one or more beamformers **1022** may be coupled between the RF units (which provide RF signal feeds) and the antenna systems. The beamformers may be controlled by the controller **402**. Those skilled in the art will appreciate that

beamformers control the amplitude and phase of a signal at each transmitter, in order to create a pattern of constructive and destructive interference that controls the directionality of the radiation pattern emitted by the antennas. The azimuth patterns can be defined, either in a digital or analog manner, by the signal weights to the antennas. In general, the weights are applied in either time or frequency domain. In the case of OFDMA, the weights are applied to the corresponding subcarriers in the frequency domain within the beamformers **1106**, as shown in FIG. **11**.

With respect to the elevation beam pattern, a desired beam pattern can be achieved by controlling how antenna elements **1002** are activated by the system. FIG. **12** depicts two representative antenna elements **1002**, such as might be fixed to an antenna substrate. The antenna elements comprise one or more electronic circuits **1202** that are surrounded by radiation elements **1204**. By activating some or all of the electronic circuits **1202**, the resulting emitted radiation beam may be adjusted in elevation. Certain elevation beam patterns may be predefined and can be activated, individually or in combination, by the antenna controller.

It will be appreciated that in certain applications of beamforming, transmit-diversity, or multiple-input-multiple-output (MIMO) transmissions in azimuth, the transmitter **400** design (including distribution network **408**) may be modified to accommodate greater antenna complexity. FIG. **13** is a block diagram of a parallel transmitter construction for such an application. Specifically, the transmitter is modified to generate N outputs from each BBP, where N corresponds to the number of antenna subsystems in the azimuth dimension or to the number of azimuth beams need to cover a desired area (e.g., a sector). The outputs from the BBPs are coupled to an array of RF transceivers **1302**, a bank of N distribution networks **1304**, and an array of RF Units **1306**. Outputs from the transmitter with a parallel construction are coupled to the antenna system and used for beamforming, transmit-diversity, or MIMO transmission.

The transmitter and antenna constructions disclosed herein enable the multiple-antenna system to switch between a variety of transmission modes that are suitable for different applications, such as audio, video, voice, etc. In one transmission mode, unicast data such as user-specific data and pilot subcarriers are transmitted to MSs by their serving BS using narrow beams (adaptively shaped or otherwise) or orthogonal beams in azimuth. Adaptive modulation and coding, as well as power control, can be jointly applied with these unicast-shaped beams.

In another transmission mode, sector-specific data and pilot subcarriers are transmitted to MSs by their serving BS using a shaped beam that covers its designated sector in azimuth. Signals that are associated the sector-specific data subcarriers include preamble, mid-amble, frame control header, downlink resource allocation, uplink resource allocation, or any information that is required to be disseminated to the MSs within the sector covered by the serving BS. Since the directivity gain of a sector beam is typically smaller than a narrow beam in the unicast case, a relatively robust modulation and coding scheme may be used for a sector-specific broadcast with a sector-shaped beam.

In still another transmission mode, broadcast data and pilot subcarriers are transmitted by a BS using a beam pattern that is shaped in both elevation and azimuth to maximize the network coverage. For example, in the same frequency network (SFN), it is desirable that the beam pattern of a BS should, to a certain degree, overlap in both azimuth and elevation with others, so as to achieve the optimal effects of macro-diversity. The gain from the macro-

diversity should be able to offset, to a certain extent, the link-budget imbalance as compared to the sector beam case and narrow beam case.

The combination of a particular scheme of frequency reuse and a specific type of transmission can be represented by a configuration index, such as the configuration index represented in column 1 of Table 1. For example, an instruction to or from the controller 402 to modify the transmission mode may be in the form of the configuration index. The controller may use a look-up table or other data construct to determine the appropriate switch 606 settings and amplifier 602 gain settings that are associated with the specified configuration index, as exemplified in Table 1. In addition, the configuration index may also dictate the type of elevation beam used for a specific transmission (e.g., “conformed” or “extended” in Table 1). Given a configuration index, the controller will control the gain, switch setting, and beamformer or other antenna control to produce a desired beam pattern for transmission or reception.

In some embodiments, mechanisms are employed to deal with the transition from one transmission mode to another transmission mode. In particular, a transition period (TP) may be inserted between transmission slots of different types of applications. For example, in the time structure shown in FIG. 3, DL Slot #1 may be a video broadcast slot and DL Slot #2 may be a data unicast slot. FIG. 14 is a block diagram depicting how the DL subframe 302 may be modified to incorporate a transition period. As depicted in FIG. 14, a transition period 1404 is inserted between a video broadcast slot 1402 and a data unicast slot 1406. The transition from one type of application to the next may require turning on/off switches and/or amplifiers, antenna control circuits, etc. The TP that is inserted must be sufficiently long for these devices to reach steady or near steady states. In addition, necessary MAC functions dealing with the TP such as scheduling and control messages will be performed by the MAC processor. It will be appreciated that the length of the transition period may be a constant that is selected based on the worst-case amount of time necessary for devices to reach steady or near steady state when switching from one transmission mode to another transmission mode. Alternatively, the length of the transition period may be varied so that it is optimized depending on the type of transition between transmission modes.

Instead of inserting a transition period to accommodate a switch from one transmission mode to another transmission mode, the transition can be scheduled to take place between OFDM symbols such that a portion of the cyclic prefix or postfix can be used for the switched devices to reach a steady or near-steady state, provided that the cyclic prefix or postfix is designed to be longer than the time required for the transition.

The above detailed description of embodiments of the system is not intended to be exhaustive or to limit the system to the precise form disclosed above. While specific embodiments of, and examples for, the system are described above for illustrative purposes, various equivalent modifications are possible within the scope of the system, as those skilled in the relevant art will recognize. For example, while processes are presented in a given order, alternative embodiments may perform routines having steps in a different order, and some processes may be deleted, moved, added, subdivided, combined, and/or modified to provide alternative or subcombinations. Each of these processes may be implemented in a variety of different ways. Further any specific numbers noted herein are only examples: alternative implementations may employ differing values or ranges.

These and other changes can be made to the invention in light of the above Detailed Description. While the above description describes certain embodiments of the technology, and describes the best mode contemplated, no matter how detailed the above appears in text, the invention can be practiced in many ways. Details of the system may vary considerably in its implementation details, while still being encompassed by the technology disclosed herein. As noted above, particular terminology used when describing certain features or aspects of the technology should not be taken to imply that the terminology is being redefined herein to be restricted to any specific characteristics, features, or aspects of the technology with which that terminology is associated. In general, the terms used in the following claims should not be construed to limit the invention to the specific embodiments disclosed in the specification, unless the above Detailed Description section explicitly defines such terms. Accordingly, the actual scope of the invention encompasses not only the disclosed embodiments, but also all equivalent ways of practicing or implementing the invention under the claims.

We claim:

1. A transmission method for a base station in a cell of an orthogonal frequency division multiplexing (OFDM) wireless system, the method comprising:

selecting a plurality of cell-specific OFDM subcarriers in a time slot for transmission to mobile devices within the cell, wherein a first weight is applied to a cell-specific OFDM subcarrier;

selecting a plurality of user-specific OFDM subcarriers in the time slot for transmission to a specific mobile device within the cell, wherein a second weight is applied to a user-specific OFDM subcarrier;

transmitting control information on the plurality of cell-specific OFDM subcarriers through a first group of antennas; and transmitting user-specific data on the plurality of user-specific OFDM subcarriers through a second group antennas;

wherein the first group of antennas produce a first beam pattern having a first azimuth pattern and first elevation pattern, and the second group of antennas produce a second beam pattern having a second azimuth pattern and second elevation pattern, and wherein the first beam pattern is different than the second beam pattern in either azimuth pattern or an elevation pattern.

2. The method of claim 1, wherein the plurality of cell-specific OFDM subcarriers comprise cell-specific data OFDM subcarriers and cell-specific pilot OFDM subcarriers.

3. The method of claim 1, wherein the plurality of user-specific OFDM subcarriers comprise user-specific data OFDM subcarriers and user-specific pilot OFDM subcarriers.

4. The method of claim 1, further comprising dividing a transmission time period into a plurality of frames, wherein each frame contains a plurality of subframes, each subframe contains a plurality of time slots, and each time slot contains a plurality of OFDM symbols.

5. The method of claim 1, wherein the control information includes downlink or uplink resource allocation information.

6. The method of claim 1, wherein the control information and the user-specific data are modulated with different modulation and coding schemes.

7. A base station in a cell of an orthogonal frequency division multiplexing (OFDM) wireless system, the base station comprising: a controller configured to:

11

select a plurality of cell-specific OFDM subcarriers in a time slot for transmission to mobile devices within the cell, wherein a first weight is applied to a cell-specific OFDM subcarrier; and
select a plurality of user-specific OFDM subcarriers in the time slot for transmission to a specific mobile device within the cell, wherein a second weight is applied to a user-specific OFDM subcarrier; and
a transmitter configured to:
transmit control information on the plurality of cell-specific OFDM subcarriers through a first group of antennas; and
transmit user-specific data on the plurality of user-specific OFDM subcarriers through a second group antennas;
wherein the first group of antennas produce a first beam pattern having a first azimuth pattern and first elevation pattern, and the second group of antennas produce a second beam pattern having a second azimuth pattern and second elevation pattern, and wherein the first

12

beam pattern is different than the second beam pattern in either an azimuth pattern or an elevation pattern.
8. The base station of claim 7, wherein the transmitter comprises a channel encoding component, a modulation component, and an inverse fast Fourier transform (IFFT) component.
9. The base station of claim 7, wherein a transmission time period is divided into a plurality of frames and each frame contains a plurality of subframes, each subframe contains a plurality of time slots, and each time slot contains a plurality of OFDM symbols.
10. The base station of claim 7, wherein the control information includes downlink or uplink resource allocation information.
11. The base station of claim 7, wherein the control information and the user-specific data are modulated with different modulation and coding schemes.

* * * * *