



US 20090251546A1

(19) **United States**

(12) **Patent Application Publication**
Silverbrook

(10) **Pub. No.: US 2009/0251546 A1**

(43) **Pub. Date: Oct. 8, 2009**

(54) **DIGITAL CAMERA WITH POSTCARD PRINTING**

(30) **Foreign Application Priority Data**

(75) Inventor: **Kia Silverbrook, Balmain (AU)**

Jul. 15, 1997 (AU) PO7991

Jul. 15, 1997 (AU) PO7999

Correspondence Address:
SILVERBROOK RESEARCH PTY LTD
393 DARLING STREET
BALMAIN 2041 (AU)

Publication Classification

(51) **Int. Cl.**
H04N 5/225 (2006.01)

(52) **U.S. Cl.** **348/207.2; 348/E05.024**

(73) Assignee: **Silverbrook Research Pty Ltd**

(57) **ABSTRACT**

(21) Appl. No.: **12/475,576**

(22) Filed: **May 31, 2009**

A digital camera is provided having an image sensor for capturing an image, an image processor for processing image data from the image sensor to produce print data, a printhead for printing the print data, and a cartridge interface for receiving a cartridge having a supply of media substrates pre-printed with postcard formatting and a memory storing information relating to the dimensions of the postcard formatting. The image processor produces the print data in accordance with the stored information accessed via the cartridge interface to produce personalised postcards.

Related U.S. Application Data

(63) Continuation of application No. 10/831,235, filed on Apr. 26, 2004, now Pat. No. 7,551,202, which is a continuation-in-part of application No. 09/112,743, filed on Jul. 10, 1998, now Pat. No. 6,727,951.

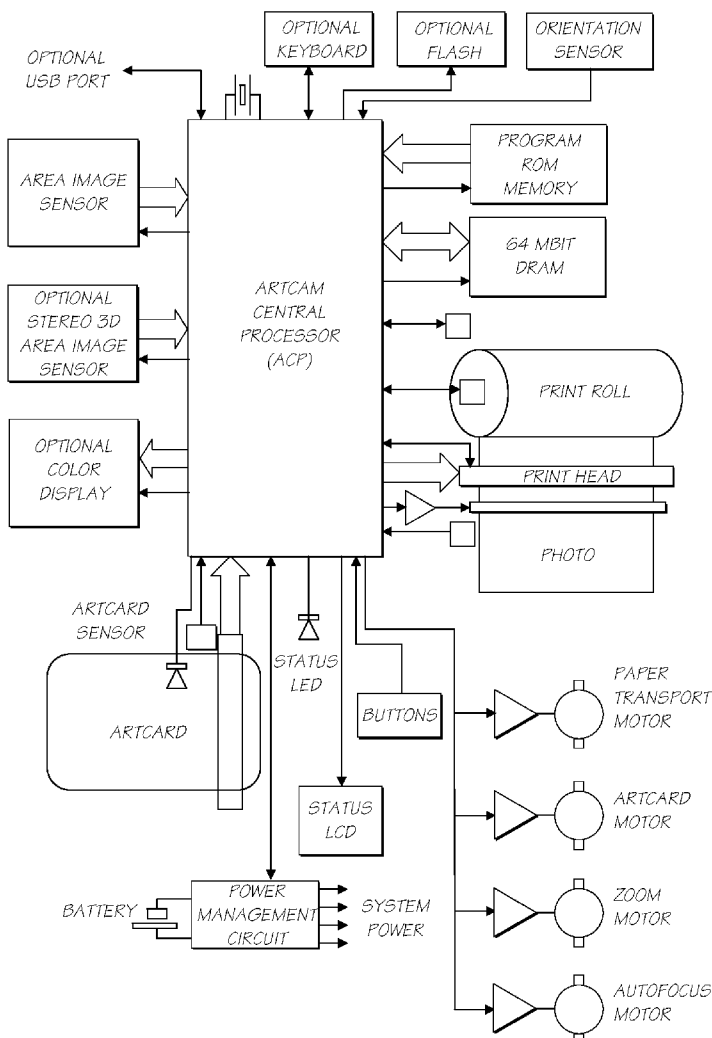

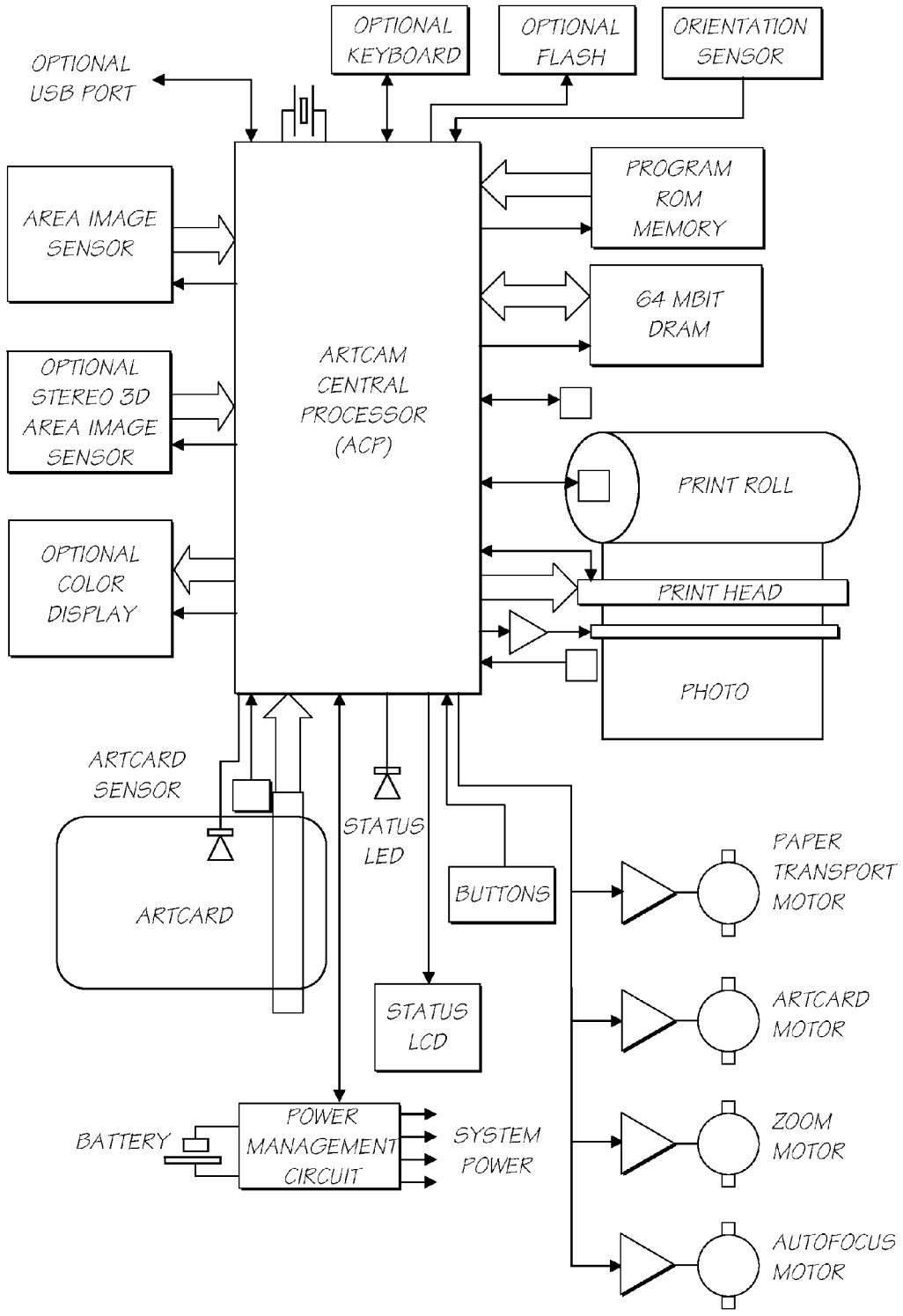

FIG. 1A

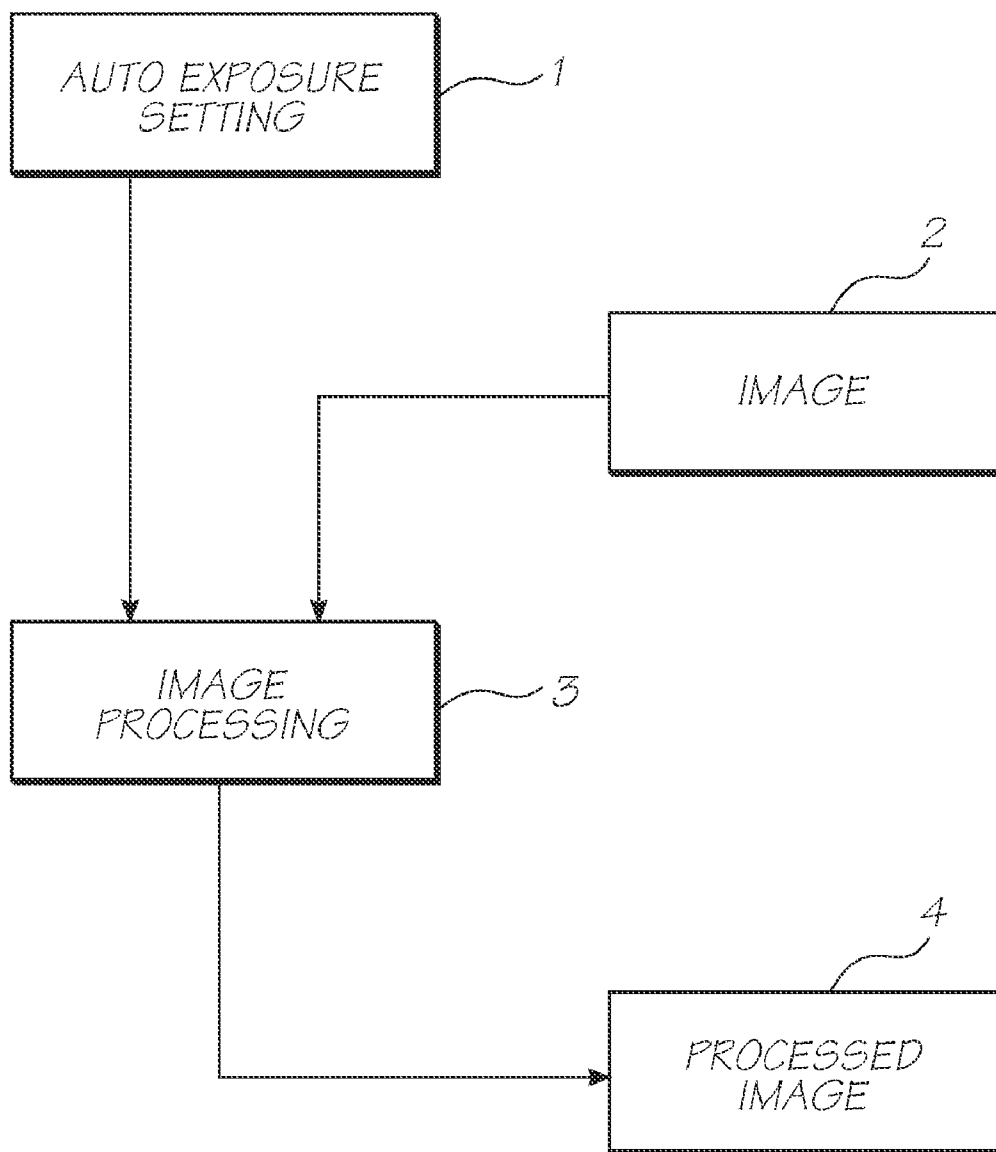

FIG. 1B

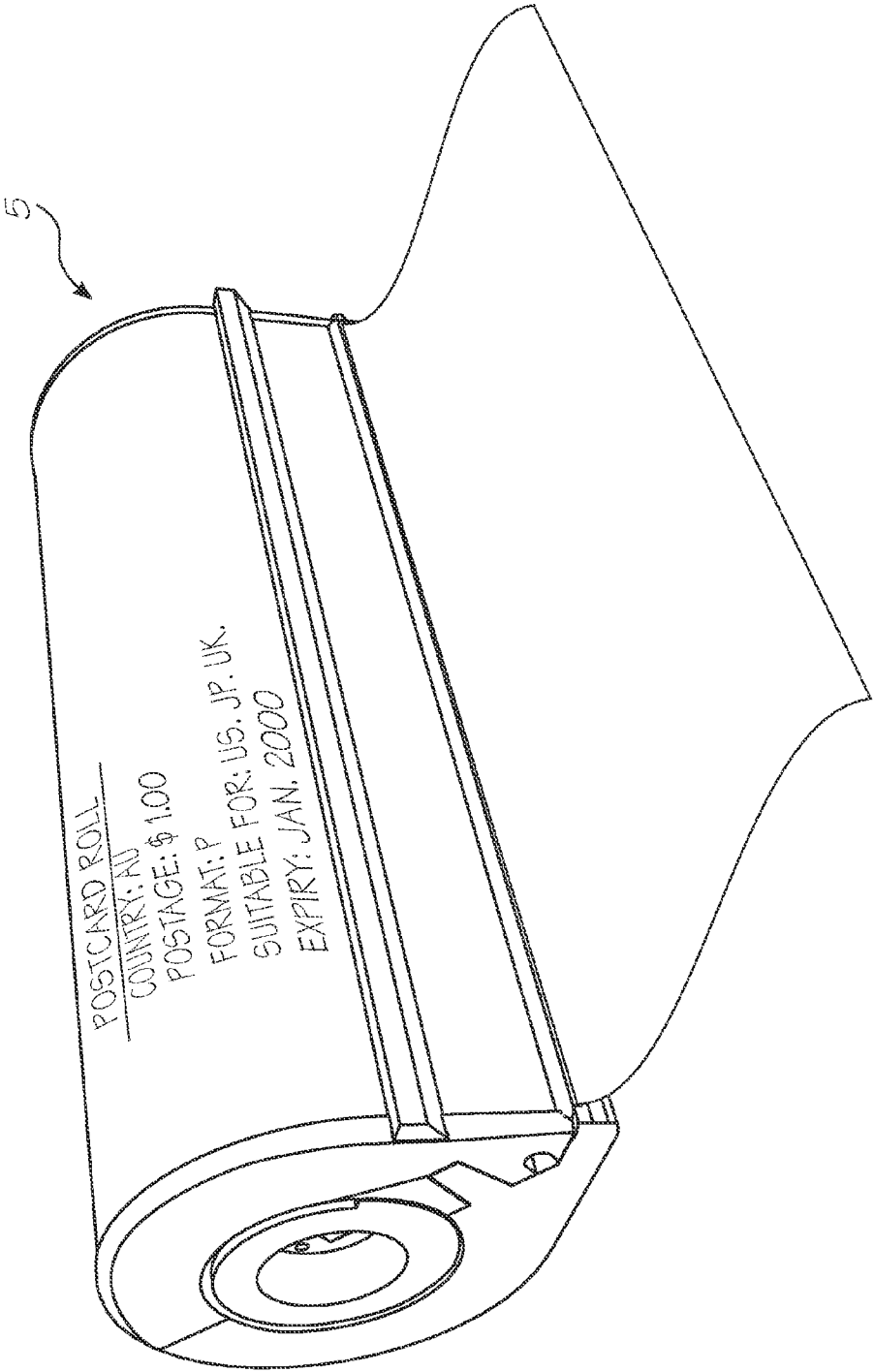

FIG. 2

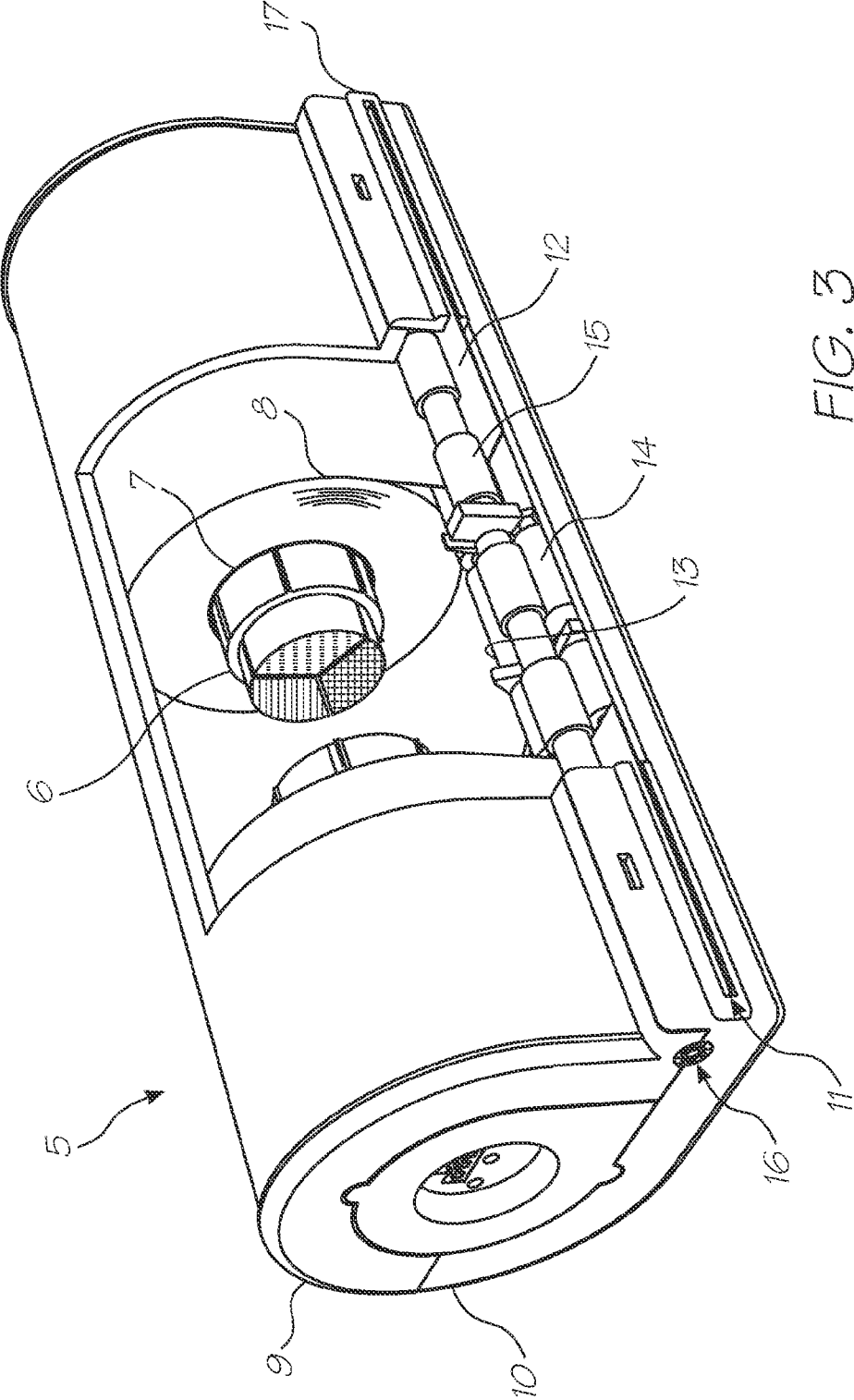

FIG. 3

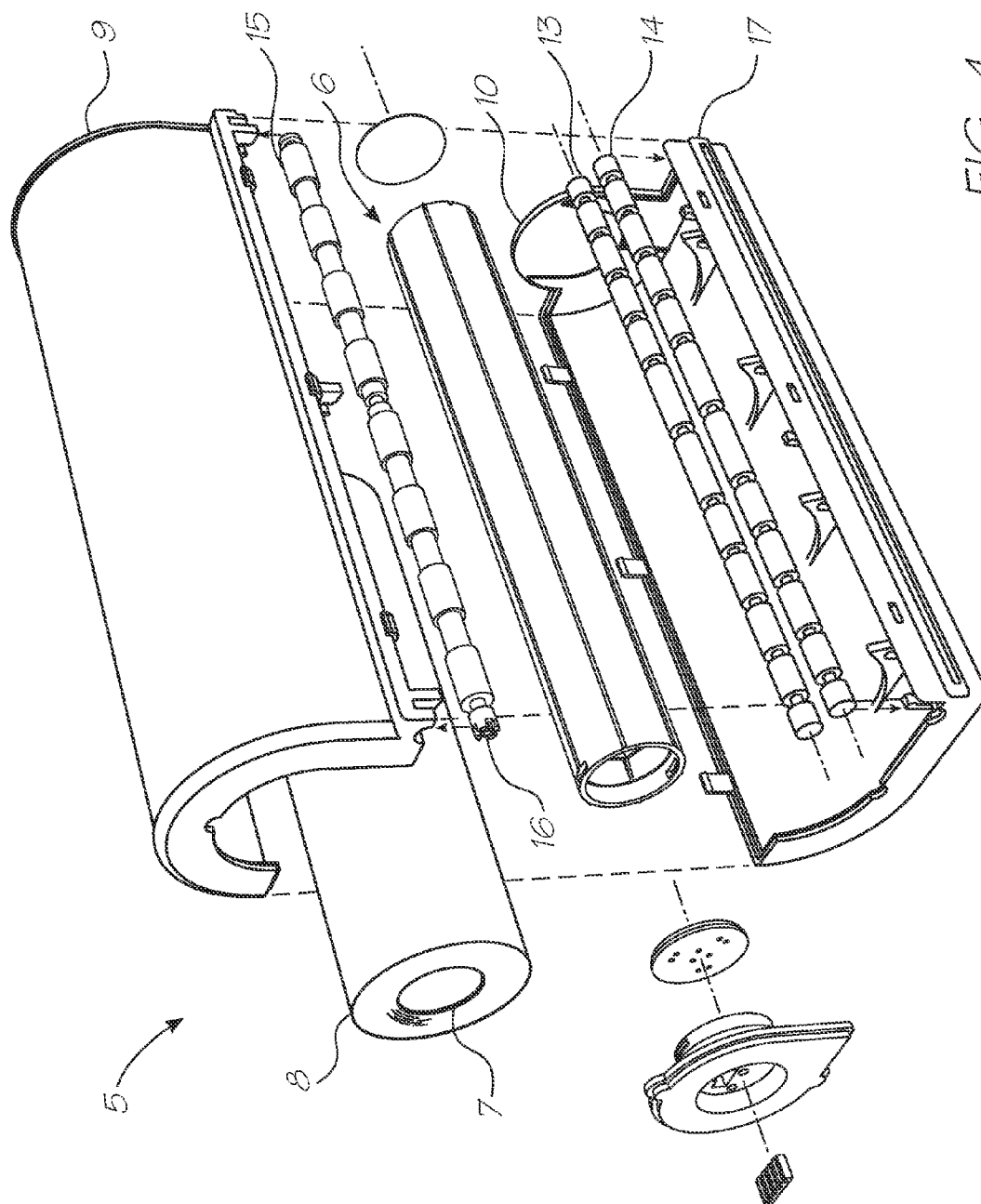
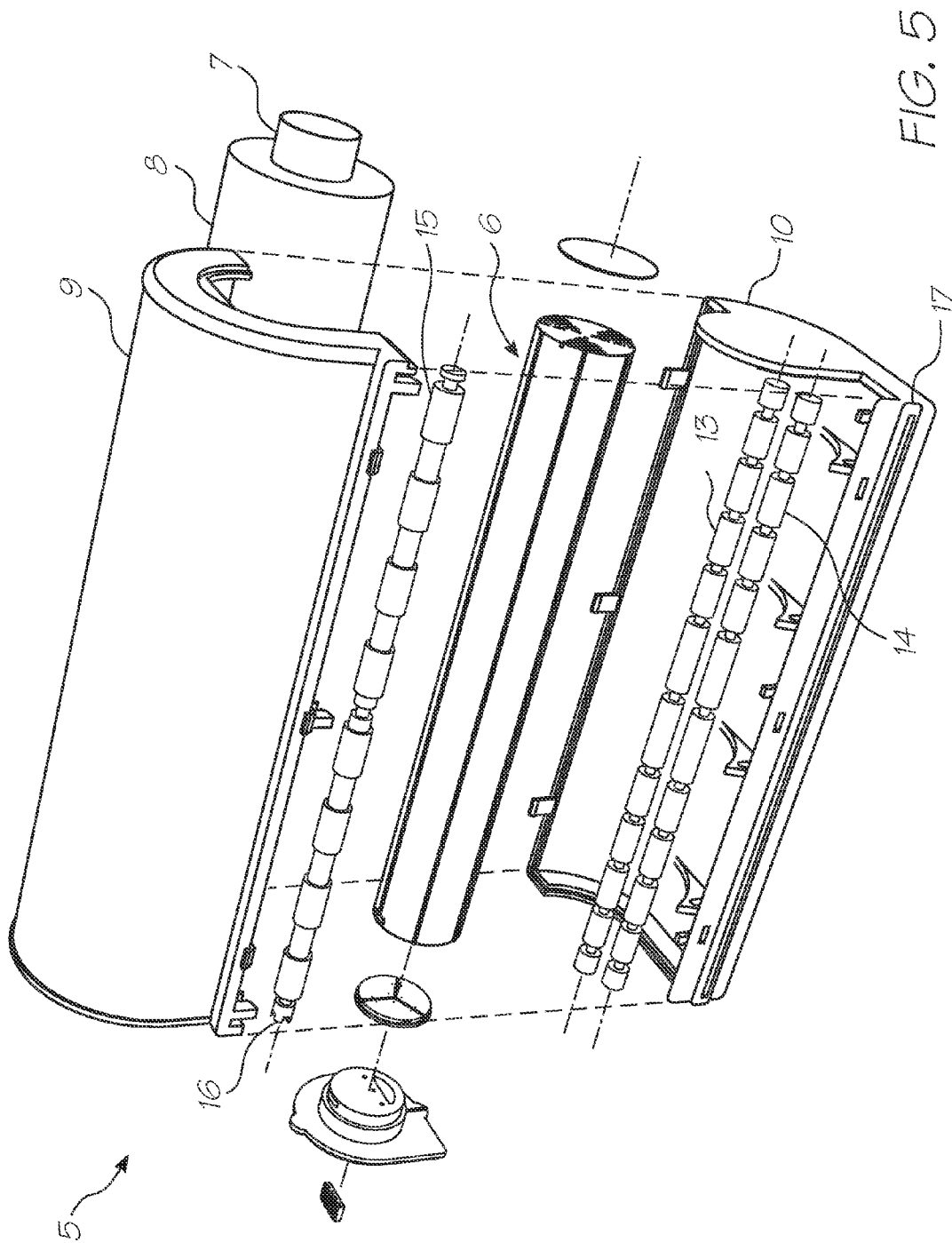

FIG. 4



DIGITAL CAMERA WITH POSTCARD PRINTING

CROSS REFERENCES TO RELATED APPLICATIONS

[0001] The present application is a continuation of U.S. application Ser. No. 10/831,235 filed Apr. 26, 2004, which is a Continuation-In-Part of U.S. application Ser. No. 09/112,743 filed on Jul. 10, 1998, now issued U.S. Pat. No. 6,727,951 all of which are herein incorporated by reference.

FIELD OF THE INVENTION

[0002] The present invention relates to digital cameras and in particular, the onboard processing of image data captured by the camera.

BACKGROUND OF THE INVENTION

[0003] Recently, digital cameras have become increasingly popular. These cameras normally operate by means of imaging a desired image utilising a charge coupled device (CCD) array and storing the imaged scene on an electronic storage medium for later down loading onto a computer system for subsequent manipulation and printing out. Normally, when utilising a computer system to print out an image, sophisticated software may available to manipulate the image in accordance with requirements.

[0004] Unfortunately such systems require significant post processing of a captured image and normally present the image in an orientation to which it was taken, relying on the post processing process to perform any necessary or required modifications of the captured image. Also, much of the environmental information available when the picture was taken is lost. Furthermore, the type or size of the media substrate and the types of ink used to print the image can also affect the image quality. Accounting for these factors during post processing of the captured image data can be complex and time consuming.

SUMMARY OF THE INVENTION

[0005] Accordingly, the present invention provides a digital camera comprising:

[0006] an image sensor for capturing an image;

[0007] an image processor for processing image data from the image sensor and transmitting processed data to a print-head; and,

[0008] an effects interface for user input of one or more predetermined image manipulations; such that,

[0009] the processed data transmitted to the printhead incorporate the selected image manipulations.

[0010] The present invention allows the user to perform many common image manipulations when the image is captured by inputting required effect via the interface. This permits the user to print the images in the camera without first downloading to a desktop system.

[0011] Preferably, data relating to the image manipulations are stored on separate portable memory devices for connection to the effects interface.

[0012] In a further preferred form, the image manipulations comprise image rotations, borders, text or clip art.

[0013] In yet another preferred form, further adapted for use with a media cartridge comprising a supply of media substrate on which images can be printed, and an information store with information relating to the media substrate, wherein the camera further comprises a cartridge interface for

accessing the information such that the image processor can utilise the information relating to the media substrate.

[0014] The camera accesses information about the media substrate so that the image processor can utilise the information to enhance the quality of the printed image.

[0015] Preferably, the media substrate has postcard formatting printed on its reverse surface so that the camera can produce personalised postcards, and the information store has the dimensions of the postcard formatting to allow the image processor to align printed images with the postcard formatting.

[0016] In a further preferred form the cartridge further comprises an ink supply for the printhead and the information store is an authentication chip that allows the image processor to confirm that the media substrate and the ink supply is suitable for use with the camera.

[0017] According to a related aspect, there is provided a digital camera for sensing and storing an image, the camera comprising:

[0018] an image sensor with a charge coupled device (CCD) for capturing image data relating to a sensed image, and an auto exposure setting for adjusting the image data captured by the CCD in response to the lighting conditions at image capture; and,

[0019] an image processor for processing image data from the CCD and storing the processed data; wherein,

[0020] the image processor is adapted to use information from the auto exposure setting relating to the lighting conditions at image capture when processing the image data from the CCD.

[0021] Utilising the auto exposure setting to determine an advantageous re-mapping of colours within the image allows the processor to produce an amended image having colours within an image transformed to account of the auto exposure setting. The processing can comprise re-mapping image colours so they appear deeper and richer when the exposure setting indicates low light conditions and re-mapping image colours to be brighter and more saturated when the auto exposure setting indicates bright light conditions.

BRIEF DESCRIPTION OF DRAWINGS

[0022] Notwithstanding any other forms which may fall within the scope of the present invention, preferred forms of the invention will now be described, by way of example only, with reference to the accompanying drawings which:

[0023] FIG. 1A illustrates an example camera device;

[0024] FIG. 1B illustrates the method of operation of the preferred embodiment;

[0025] FIG. 2 illustrates a form of print roll ready for purchase by a consumer;

[0026] FIG. 3 illustrates a perspective view, partly in section, of an alternative form of a print roll;

[0027] FIG. 4 is a left side exploded perspective view of the print roll of FIG. 3; and,

[0028] FIG. 5 is a right side exploded perspective view of a single print roll.

DESCRIPTION OF PREFERRED AND OTHER EMBODIMENTS

[0029] The preferred embodiment is preferable implemented through suitable programming of a hand held camera device such as that described in the present applicant's application entitled "A Digital Image Printing Camera with Image Processing Capability", the content of which is hereby specifically incorporated by cross reference and the details of

which, and other related applications are set out in the tables below. An example of a camera device **100** is shown in FIG. **1A**.

[0030] The aforementioned patent specification discloses a camera system, hereinafter known as an "Artcam" type camera, wherein sensed images can be directly printed out by an Artcam portable camera unit. Further, the aforementioned specification discloses means and methods for performing various manipulations on images captured by the camera sensing device leading to the production of various effects in any output image. The manipulations are disclosed to be highly flexible in nature and can be implemented through the insertion into the Artcam of cards having encoded thereon various instructions for the manipulation of images, the cards hereinafter being known as Artcards. The Artcam further has significant onboard processing power by an Artcam Central Processor unit (ACP) which is interconnected to a memory device for the storage of important data and images.

[0031] In the preferred embodiment, the Artcam has an auto exposure sensor for determining the light level associated with the captured image. This auto exposure sensor is utilised to process the image in accordance with the set light value so as to enhance portions of the image.

[0032] Preferably, the area image sensor includes a means for determining the light conditions when capturing an image. The area image sensor adjusts the dynamic range of values captured by the CCD in accordance with the detected level sensor. The captured image is transferred to the Artcam central processor and stored in the memory store. Intensity information, as determined by the area image sensor, is also forwarded to the ACP. This information is utilised by the Artcam central processor to manipulate the stored image to enhance certain effects.

[0033] Turning now to FIG. **1**, the auto exposure setting information **1** is utilised in conjunction with the stored image **2** to process the image by utilising the ACP. The processed image is returned to the memory store for later printing out **4** on the output printer.

[0034] A number of processing steps can be undertaken in accordance with the determined light conditions. Where the auto exposure setting **1** indicates that the image was taken in a low light condition, the image pixel colours are selectively re-mapped so as to make the image colours stronger, deeper and richer.

[0035] Where the auto exposure information indicates that highlight conditions were present when the image was taken, the image colours can be processed to make them brighter and more saturated. The re-colouring of the image can be undertaken by conversion of the image to a hue-saturation-value (HSV) format and an alteration of pixel values in accordance with requirements. The pixel values can then be output converted to the required output colour format of printing.

[0036] Of course, many different re-colouring techniques may be utilised. Preferably, the techniques are clearly illustrated on the pre-requisite Artcard inserted into the reader.

[0037] Alternatively, the image processing algorithms can be automatically applied and hard-wired into the camera for utilization in certain conditions.

[0038] Alternatively, the Artcard inserted could have a number of manipulations applied to the image which are specific to the auto-exposure setting. For example, clip arts containing candles etc could be inserted in a dark image and large suns inserted in bright images.

[0039] Referring now to FIGS. **2** to **5**, the Artcam prints the images onto media stored in a replaceable print roll **5**. In some preferred embodiments, the operation of the camera device is such that when a series of images is printed on a first surface

of the print roll, the corresponding backing surface has a ready made postcard which can be immediately dispatched at the nearest post office box within the jurisdiction. In this way, personalized postcards can be created.

[0040] It would be evident that when utilising the postcard system as illustrated FIG. **2** only predetermined image sizes are possible as the synchronization between the backing postcard portion and the front image must be maintained. This can be achieved by utilising the memory portions of the authentication chip stored within the print roll **5** to store details of the length of each postcard backing format sheet. This can be achieved by either having each postcard the same size or by storing each size within the print rolls on-board print chip memory.

[0041] In an alternative embodiment, there is provided a modified form of print roll which can be constructed mostly from injection moulded plastic pieces suitably snapped fitted together. The modified form of print roll has a high ink storage capacity in addition to a somewhat simplified construction. The print media onto which the image is to be printed is wrapped around a plastic sleeve former for simplified construction. The ink media reservoir has a series of air vents which are constructed so as to minimise the opportunities for the ink flow out of the air vents. Further, a rubber seal is provided for the ink outlet holes with the rubber seal being pierced on insertion of the print roll into a camera system. Further, the print roll includes a print media ejection slot and the ejection slot includes a surrounding moulded surface which provides and assists in the accurate positioning of the print media ejection slot relative to the printhead within the printing or camera system.

[0042] Turning to FIG. **3** there is illustrated a single point roll unit **5** in an assembled form with a partial cutaway showing internal portions of the print roll. FIG. **4** and FIG. **5** illustrate left and right side exploded perspective views respectively. The print roll **5** is constructed around the internal core portion **6** which contains an internal ink supply. Outside of the core portion **6** is provided a former **7** around which is wrapped a paper or film supply **8**. Around the paper supply it is constructed two cover pieces **9**, **10** which snap together around the print roll so as to form a covering unit as illustrated in FIG. **3**. The bottom cover piece **10** includes a slot **11** through which the output of the print media **12** for interconnection with the camera system.

[0043] Two pinch rollers **13**, **14** are provided to pinch the paper against a drive pinch roller **15** so they together provide for a decurling of the paper around the roller **15**. The decurling acts to negate the strong curl that may be imparted to the paper from being stored in the form of print roll for an extended period of time. The rollers **13**, **14** are provided to form a snap fit with end portions of the cover base portion **10** and the roller **15** which includes a cogged end **16** for driving, snap fits into the upper cover piece **9** so as to pinch the paper **12** firmly between.

[0044] The cover pieces **9**, **10** includes an end protuberance or lip **17**. The end lip **17** is provided for accurately alignment of the exit hole of the paper with a corresponding printing heat platen structure within the camera system. In this way, accurate alignment or positioning of the exiting paper relative to an adjacent printhead is provided for full guidance of the paper to the printhead.

[0045] It would be appreciated by a person skilled in the art that numerous variations and/or modifications may be made to the present invention as shown in the specific embodiment without departing from the spirit or scope of the invention as

broadly described. The present embodiment is, therefore, to be considered in all respects to be illustrative and not restrictive.

[0046] The present invention is best utilized in the Artcam device, the details of which are set out in the following paragraphs.

Ink Jet Technologies

[0047] The embodiments of the invention use an ink jet printer type device. Of course many different devices could be used. However presently popular ink jet printing technologies are unlikely to be suitable.

[0048] The most significant problem with thermal inkjet is power consumption. This is approximately 100 times that required for high speed, and stems from the energy-inefficient means of drop ejection. This involves the rapid boiling of water to produce a vapor bubble which expels the ink. Water has a very high heat capacity, and must be superheated in thermal inkjet applications. This leads to an efficiency of around 0.02%, from electricity input to drop momentum (and increased surface area) out.

[0049] The most significant problem with piezoelectric inkjet is size and cost. Piezoelectric crystals have a very small deflection at reasonable drive voltages, and therefore require a large area for each nozzle. Also, each piezoelectric actuator must be connected to its drive circuit on a separate substrate. This is not a significant problem at the current limit of around 300 nozzles per print head, but is a major impediment to the fabrication of pagewide print heads with 19,200 nozzles.

[0050] Ideally, the inkjet technologies used meet the stringent requirements of in-camera digital color printing and other high quality, high speed, low cost printing applications. To meet the requirements of digital photography, new inkjet technologies have been created. The target features include:

[0051] low power (less than 10 Watts)

[0052] high resolution capability (1,600 dpi or more)

[0053] photographic quality output

[0054] low manufacturing cost

[0055] small size (pagewidth times minimum cross section)

[0056] high speed (<2 seconds per page).

[0057] All of these features can be met or exceeded by the inkjet systems described below with differing levels of difficulty. 45 different inkjet technologies have been developed by the Assignee to give a wide range of choices for high volume manufacture. These technologies form part of separate applications assigned to the present Assignee as set out in the table below.

[0058] The inkjet designs shown here are suitable for a wide range of digital printing systems, from battery powered one-time use digital cameras, through to desktop and network printers, and through to commercial printing systems

[0059] For ease of manufacture using standard process equipment, the print head is designed to be a monolithic 0.5 micron CMOS chip with MEMS post processing. For color photographic applications, the print head is 100 mm long, with a width which depends upon the inkjet type. The smallest print head designed is IJ38, which is 0.35 mm wide, giving a chip area of 35 square mm. The print heads each contain 19,200 nozzles plus data and control circuitry.

[0060] Ink is supplied to the back of the print head by injection molded plastic ink channels. The molding requires 50 micron features, which can be created using a lithographically micromachined insert in a standard injection molding tool. Ink flows through holes etched through the wafer to the

nozzle chambers fabricated on the front surface of the wafer. The print head is connected to the camera circuitry by tape automated bonding.

CROSS-REFERENCED APPLICATIONS

[0061] The following table is a guide to cross-referenced patent applications filed concurrently herewith and discussed hereinafter with the reference being utilized in subsequent tables when referring to a particular case:

Docket No	Reference	Title
IJ01US	6227652	Radiant Plunger Ink Jet Printer
IJ02US	6213588	Electrostatic Ink Jet Printing Mechanism
IJ03US	6213589	Planar Thermoelastic Bend Actuator Ink Jet Printing Mechanism
IJ04US	6231163	Stacked Electrostatic Ink Jet Printing Mechanism
IJ05US	6247795	Reverse Spring Lever Ink Jet Printing Mechanism
IJ06US	6394581	Paddle Type Ink Jet Printing Mechanism
IJ07US	6244691	Ink Jet Printing Mechanism
IJ08US	6257704	Planar Swing Grill Electromagnetic Ink Jet Printing Mechanism
IJ09US	6416168	Pump Action Refill Ink Jet Printing Mechanism
IJ10US	6220694	Pulsed Magnetic Field Ink Jet Printing Mechanism
IJ11US	6257705	Two Plate Reverse Firing Electromagnetic Ink Jet Printing Mechanism
IJ12US	6247794	Linear Stepper Actuator Ink Jet Printing Mechanism
IJ13US	6234610	Gear Driven Shutter Ink Jet Printing Mechanism
IJ14US	6247793	Tapered Magnetic Pole Electromagnetic Ink Jet Printing Mechanism
IJ15US	6264306	Linear Spring Electromagnetic Grill Ink Jet Printing Mechanism
IJ16US	6241342	Lorenz Diaphragm Electromagnetic Ink Jet Printing Mechanism
IJ17US	6247792	PTFE Surface Shooting Shuttered Oscillating Pressure Ink Jet Printing Mechanism
IJ18US	6264307	Buckle Grill Oscillating Pressure Ink Jet Printing Mechanism
IJ19US	6254220	Shutter Based Ink Jet Printing Mechanism
IJ20US	6234611	Curling Calyx Thermoelastic Ink Jet Printing Mechanism
IJ21US	6302528	Thermal Actuated Ink Jet Printing Mechanism
IJ22US	6283582	Iris Motion Ink Jet Printing Mechanism
IJ23US	6239821	Direct Firing Thermal Bend Actuator Ink Jet Printing Mechanism
IJ24US	6338547	Conductive PTFE Bend Actuator Vented Ink Jet Printing Mechanism
IJ25US	6247796	Magnetostrictive Ink Jet Printing Mechanism
IJ26US	6557977	Shape Memory Alloy Ink Jet Printing Mechanism
IJ27US	6390603	Buckle Plate Ink Jet Printing Mechanism
IJ28US	6362843	Thermal Elastic Rotary Impeller Ink Jet Printing Mechanism
IJ29US	6293653	Thermoelastic Bend Actuator Ink Jet Printing Mechanism
IJ30US	6312107	Thermoelastic Bend Actuator Using PTFE Corrugated Heater Ink Jet Printing Mechanism
IJ31US	6227653	Bend Actuator Direct Ink Supply Ink Jet Printing Mechanism
IJ32US	6234609	High Young's Modulus Thermoelastic Ink Jet Printing Mechanism
IJ33US	6238040	Thermally Actuated Slotted Chamber Wall Ink Jet Printing Mechanism

-continued

Docket No	Reference	Title
IJ34US	6188415	Ink Jet Printer having a Thermal Actuator Comprising an External Coil Spring
IJ35US	6227654	Trough Container Ink Jet Printing Mechanism with Paddle
IJ36US	6209989	Dual Chamber Single Actuator Ink Jet Printing Mechanism
IJ37US	6247791	Dual Nozzle Single Horizontal Fulcrum Actuator Ink Jet Printing Mechanism
IJ38US	6336710	Dual Nozzle Single Horizontal Actuator Ink Jet Printing Mechanism
IJ39US	6217153	Single Bend Actuator Cupped Paddle Ink Jet Printing Mechanism
IJ40US	6416167	Thermally Actuated Ink Jet Printing Mechanism having a Series of Thermal Actuator Units
IJ41US	6243113	Thermally Actuated Ink Jet Printing Mechanism including a Tapered Heater Element
IJ42US	6283581	Radial Back-Curling Thermoelastic Ink Jet Printing Mechanism
IJ43US	6247790	Inverted Radial Back-Curling Thermoelastic Ink Jet Printing Mechanism
IJ44US	6260953	Surface Bend Actuator Vented Ink Supply Ink Jet Printing Mechanism
IJ45US	6267469	A Solenoid Actuated Magnetic Plate Ink Jet Printing Mechanism

Tables of Drop-on-Demand Inkjets

[0062] Eleven important characteristics of the fundamental operation of individual inkjet nozzles have been identified. These characteristics are largely orthogonal, and so can be elucidated as an eleven dimensional matrix. Most of the eleven axes of this matrix include entries developed by the present assignee.

[0063] The following tables form the axes of an eleven dimensional table of inkjet types.

[0064] Actuator mechanism (18 types)

[0065] Basic operation mode (7 types)

[0066] Auxiliary mechanism (8 types)

[0067] Actuator amplification or modification method (17 types)

[0068] Actuator motion (19 types)

[0069] Nozzle refill method (4 types)

[0070] Method of restricting back-flow through inlet (10 types)

[0071] Nozzle clearing method (9 types)

[0072] Nozzle plate construction (9 types)

[0073] Drop ejection direction (5 types)

[0074] Ink type (7 types)

[0075] The complete eleven dimensional table represented by these axes contains 36.9 billion possible configurations of inkjet nozzle. While not all of the possible combinations result in a viable inkjet technology, many million configurations are viable. It is clearly impractical to elucidate all of the possible configurations. Instead, certain inkjet types have been investigated in detail. These are designated IJ01 to IJ45 above.

[0076] Other inkjet configurations can readily be derived from these 45 examples by substituting alternative configurations along one or more of the 11 axes. Most of the IJ01 to IJ45 examples can be made into inkjet print heads with characteristics superior to any currently available inkjet technology.

[0077] Where there are prior art examples known to the inventor, one or more of these examples are listed in the examples column of the tables below. The IJ01 to IJ45 series are also listed in the examples column. In some cases, a printer may be listed more than once in a table, where it shares characteristics with more than one entry.

[0078] Suitable applications include: Home printers, Office network printers, Short run digital printers, Commercial print systems, Fabric printers, Pocket printers, Internet WWW printers, Video printers, Medical imaging, Wide format printers, Notebook PC printers, Fax machines, Industrial printing systems, Photocopiers, Photographic minilabs etc.

[0079] The information associated with the aforementioned 11 dimensional matrix are set out in the following tables.

Actuator Mechanism (Applied Only to Selected Ink Drops)

[0080]

Actuator Mechanism	Description	Advantages	Disadvantages	Examples
Thermal bubble	An electrothermal heater heats the ink to above boiling point, transferring significant heat to the aqueous ink. A bubble nucleates and quickly forms, expelling the ink. The efficiency of the process is low, with typically less than 0.05% of the electrical energy being transformed into kinetic energy of the drop.	Large force generated Simple construction No moving parts Fast operation Small chip area required for actuator	High power Ink carrier limited to water Low efficiency High temperatures required High mechanical stress Unusual materials required Large drive transistors Cavitation causes actuator failure Kogation reduces bubble formation Large print heads are difficult to fabricate	Canon Bubblejet 1979 Endo et al GB patent 2,007,162 Xerox heater-in-pit 1990 Hawkins et al U.S. Pat. No. 4,899,181 Hewlett-Packard TII 1982 Vaught et al U.S. Pat. No. 4,490,728
Piezoelectric	A piezoelectric crystal such as lead lanthanum zirconate (PZT) is electrically activated, and either expands, shears, or bends to apply pressure to the ink, ejecting drops.	Low power consumption Many ink types can be used Fast operation High efficiency	Very large area required for actuator Difficult to integrate with electronics High voltage drive transistors required Full pagewidth print heads impractical due to actuator size Requires electrical poling in high field strengths during manufacture	Kyser et al U.S. Pat. No. 3,946,398 Zoltan U.S. Pat. No. 3,683,212 1973 Stemme U.S. Pat. No. 3,747,120 Epson Stylus Tektronix IJ04

-continued

Actuator Mechanism	Description	Advantages	Disadvantages	Examples
Electrostrictive	An electric field is used to activate electrostriction in relaxor materials such as lead lanthanum zirconate titanate (PLZT) or lead magnesium niobate (PMN).	Low power consumption Many ink types can be used Low thermal expansion Electric field strength required (approx. 3.5 V/ μm) can be generated without difficulty Does not require electrical poling	Low maximum strain (approx. 0.01%) Large area required for actuator due to low strain Response speed is marginal ($\sim 10 \mu\text{s}$) High voltage drive transistors required Full pagewidth print heads impractical due to actuator size	Seiko Epson, Usui et al JP 253401/96 IJ04
Ferroelectric	An electric field is used to induce a phase transition between the antiferroelectric (AFE) and ferroelectric (FE) phase. Perovskite materials such as tin modified lead lanthanum zirconate titanate (PLZSnT) exhibit large strains of up to 1% associated with the AFE to FE phase transition.	Low power consumption Many ink types can be used Fast operation ($<1 \mu\text{s}$) Relatively high longitudinal strain High efficiency Electric field strength of around 3 V/ μm can be readily provided	Difficult to integrate with electronics Unusual materials such as PLZSnT are required Actuators require a large area	IJ04
Electrostatic plates	Conductive plates are separated by a compressible or fluid dielectric (usually air). Upon application of a voltage, the plates attract each other and displace ink, causing drop ejection. The conductive plates may be in a comb or honeycomb structure, or stacked to increase the surface area and therefore the force.	Low power consumption Many ink types can be used Fast operation	Difficult to operate electrostatic devices in an aqueous environment The electrostatic actuator will normally need to be separated from the ink Very large area required to achieve high forces High voltage drive transistors may be required Full pagewidth print heads are not competitive due to actuator size	IJ02, IJ04
Electrostatic pull on ink	A strong electric field is applied to the ink, whereupon electrostatic attraction accelerates the ink towards the print medium.	Low current consumption Low temperature	High voltage required May be damaged by sparks due to air breakdown Required field strength increases as the drop size decreases High voltage drive transistors required Electrostatic field attracts dust	1989 Saito et al, U.S. Pat. No. 4,799,068 1989 Miura et al, U.S. Pat. No. 4,810,954 Tone-jet
Permanent magnet electro-magnetic	An electromagnet directly attracts a permanent magnet, displacing ink and causing drop ejection. Rare earth magnets with a field strength around 1 Tesla can be used. Examples are: Samarium Cobalt (SaCo) and magnetic materials in the neodymium iron boron family (NdFeB, NdDyFeBNb, NdDyFeB, etc)	Low power consumption Many ink types can be used Fast operation High efficiency Easy extension from single nozzles to pagewidth print heads	Complex fabrication Permanent magnetic material such as Neodymium Iron Boron (NdFeB) required. High local currents required Copper metalization should be used for long electromigration lifetime and low resistivity Pigmented inks are usually infeasible Operating temperature limited to the Curie temperature (around 540 K)	IJ07, IJ10
Soft magnetic core electro-magnetic	A solenoid induced a magnetic field in a soft magnetic core or yoke fabricated from a ferrous material such as electroplated iron alloys such as CoNiFe [1], CoFe, or NiFe alloys. Typically, the soft magnetic material is in two parts, which are normally held apart by a spring. When the solenoid is actuated, the two parts attract, displacing the ink.	Low power consumption Many ink types can be used Fast operation High efficiency Easy extension from single nozzles to pagewidth print heads	Complex fabrication Materials not usually present in a CMOS fab such as NiFe, CoNiFe, or CoFe are required High local currents required Copper metalization should be used for long electromigration lifetime and low resistivity Electroplating is required High saturation flux density is required (2.0-2.1 T is achievable with CoNiFe [1])	IJ01, IJ05, IJ08, IJ10 IJ12, IJ14, IJ15, IJ17
Magnetic Lorenz force	The Lorenz force acting on a current carrying wire in a magnetic field is utilized. This allows the magnetic field to be supplied externally to the print head, for example with rare earth permanent magnets. Only the current carrying wire need be fabricated on the print-head, simplifying materials requirements.	Low power consumption Many ink types can be used Fast operation High efficiency Easy extension from single nozzles to pagewidth print heads	Force acts as a twisting motion Typically, only a quarter of the solenoid length provides force in a useful direction High local currents required Copper metalization should be used for long electromigration lifetime and low resistivity Pigmented inks are usually infeasible	IJ06, IJ11, IJ13, IJ16

-continued

Actuator Mechanism	Description	Advantages	Disadvantages	Examples
Magnetostriction	The actuator uses the giant magnetostrictive effect of materials such as Terfenol-D (an alloy of terbium, dysprosium and iron developed at the Naval Ordnance Laboratory, hence Ter-Fe-NOL). For best efficiency, the actuator should be pre-stressed to approx. 8 MPa.	Many ink types can be used Fast operation Easy extension from single nozzles to pagewidth print heads High force is available	Force acts as a twisting motion Unusual materials such as Terfenol-D are required High local currents required Copper metalization should be used for long electromigration lifetime and low resistivity Pre-stressing may be required	Fischenbeck, U.S. Pat. No. 4,032,929 IJ25
Surface tension reduction	Ink under positive pressure is held in a nozzle by surface tension. The surface tension of the ink is reduced below the bubble threshold, causing the ink to egress from the nozzle.	Low power consumption Simple construction No unusual materials required in fabrication High efficiency Easy extension from single nozzles to pagewidth print heads	Requires supplementary force to effect drop separation Requires special ink surfactants Speed may be limited by surfactant properties	Silverbrook, EP 0771 658 A2 and related patent applications
Viscosity reduction	The ink viscosity is locally reduced to select which drops are to be ejected. A viscosity reduction can be achieved electrothermally with most inks, but special inks can be engineered for a 100:1 viscosity reduction.	Simple construction No unusual materials required in fabrication Easy extension from single nozzles to pagewidth print heads	Requires supplementary force to effect drop separation Requires special ink viscosity properties High speed is difficult to achieve Requires oscillating ink pressure A high temperature difference (typically 80 degrees) is required	Silverbrook, EP 0771 658 A2 and related patent applications
Acoustic	An acoustic wave is generated and focussed upon the drop ejection region.	Can operate without a nozzle plate	Complex drive circuitry Complex fabrication Low efficiency Poor control of drop position Poor control of drop volume	1993 Hadimioglu et al, EUP 550,192 1993 Elrod et al, EUP 572,220
Thermoelastic bend actuator	An actuator which relies upon differential thermal expansion upon Joule heating is used.	Low power consumption Many ink types can be used Simple planar fabrication Small chip area required for each actuator Fast operation High efficiency CMOS compatible voltages and currents Standard MEMS processes can be used Easy extension from single nozzles to pagewidth print heads	Efficient aqueous operation requires a thermal insulator on the hot side Corrosion prevention can be difficult Pigmented inks may be infeasible, as pigment particles may jam the bend actuator	IJ03, IJ09, IJ17, IJ18 IJ19, IJ20, IJ21, IJ22 IJ23, IJ24, IJ27, IJ28 IJ29, IJ30, IJ31, IJ32 IJ33, IJ34, IJ35, IJ36 IJ37, IJ38, IJ39, IJ40 IJ41
High CTE thermoelastic actuator	A material with a very high coefficient of thermal expansion (CTE) such as polytetrafluoroethylene (PTFE) is used. As high CTE materials are usually non-conductive, a heater fabricated from a conductive material is incorporated. A 50 μm long PTFE bend actuator with polysilicon heater and 15 mW power input can provide 180 μN force and 10 μm deflection. Actuator motions include: 1) Bend 2) Push 3) Buckle 4) Rotate	High force can be generated PTFE is a candidate for low dielectric constant insulation in ULSI Very low power consumption Many ink types can be used Simple planar fabrication Small chip area required for each actuator Fast operation High efficiency CMOS compatible voltages and currents Easy extension from single nozzles to pagewidth print heads	Requires special material (e.g. PTFE) Requires a PTFE deposition process, which is not yet standard in ULSI fabs PTFE deposition cannot be followed with high temperature (above 350° C.) processing Pigmented inks may be infeasible, as pigment particles may jam the bend actuator	IJ09, IJ17, IJ18, IJ20 IJ21, IJ22, IJ23, IJ24 IJ27, IJ28, IJ29, IJ30 IJ31, IJ42, IJ43, IJ44
Conductive polymer thermoelastic actuator	A polymer with a high coefficient of thermal expansion (such as PTFE) is doped with conducting substances to increase its conductivity to about 3 orders of magnitude below that of copper. The conducting polymer expands when resistively heated. Examples of conducting dopants include: 1) Carbon nanotubes 2) Metal fibers	High force can be generated Very low power consumption Many ink types can be used Simple planar fabrication Small chip area required for each actuator Fast operation High efficiency CMOS compatible voltages and currents Easy extension from single	Requires special materials development (High CTE conductive polymer) Requires a PTFE deposition process, which is not yet standard in ULSI fabs PTFE deposition cannot be followed with high temperature (above 350° C.) processing Evaporation and CVD deposition techniques cannot be used Pigmented inks may be infeasible, as	IJ24

-continued

Actuator Mechanism	Description	Advantages	Disadvantages	Examples
Shape memory alloy	3) Conductive polymers such as doped polythiophene 4) Carbon granules	nozzles to pagewidth print heads	pigment particles may jam the bend actuator	
	A shape memory alloy such as TiNi (also known as Nitinol - Nickel Titanium alloy developed at the Naval Ordnance Laboratory) is thermally switched between its weak martensitic state and its high stiffness austenitic state. The shape of the actuator in its martensitic state is deformed relative to the austenitic shape. The shape change causes ejection of a drop.	High force is available (stresses of hundreds of MPa) Large strain is available (more than 3%) High corrosion resistance Simple construction Easy extension from single nozzles to pagewidth print heads Low voltage operation	Fatigue limits maximum number of cycles Low strain (1%) is required to extend fatigue resistance Cycle rate limited by heat removal Requires unusual materials (TiNi) The latent heat of transformation must be provided High current operation Requires pre-stressing to distort the martensitic state	IJ26
Linear Magnetic Actuator	Linear magnetic actuators include the Linear Induction Actuator (LIA), Linear Permanent Magnet Synchronous Actuator (LPMSA), Linear Reluctance Synchronous Actuator (LRSA), Linear Switched Reluctance Actuator (LSRA), and the Linear Stepper Actuator (LSA).	Linear Magnetic actuators can be constructed with high thrust, long travel, and high efficiency using planar semiconductor fabrication techniques Long actuator travel is available Medium force is available Low voltage operation	Requires unusual semiconductor materials such as soft magnetic alloys (e.g. CoNiFe [1]) Some varieties also require permanent magnetic materials such as Neodymium iron boron (NdFeB) Requires complex multi-phase drive circuitry High current operation	IJ12

Basic Operation Mode

[0081]

Operational mode	Description	Advantages	Disadvantages	Examples
Actuator directly pushes ink	This is the simplest mode of operation: the actuator directly supplies sufficient kinetic energy to expel the drop. The drop must have a sufficient velocity to overcome the surface tension.	Simple operation No external fields required Satellite drops can be avoided if drop velocity is less than 4 m/s Can be efficient, depending upon the actuator used	Drop repetition rate is usually limited to less than 10 KHz. However, this is not fundamental to the method, but is related to the refill method normally used All of the drop kinetic energy must be provided by the actuator Satellite drops usually form if drop velocity is greater than 4.5 m/s	Thermal inkjet Piezoelectric inkjet IJ01, IJ02, IJ03, IJ04 IJ05, IJ06, IJ07, IJ09 IJ11, IJ12, IJ14, IJ16 IJ20, IJ22, IJ23, IJ24 IJ25, IJ26, IJ27, IJ28 IJ29, IJ30, IJ31, IJ32 IJ33, IJ34, IJ35, IJ36 IJ37, IJ38, IJ39, IJ40 IJ41, IJ42, IJ43, IJ44 Silverbrook, EP 0771 658 A2 and related patent applications
Proximity	The drops to be printed are selected by some manner (e.g. thermally induced surface tension reduction of pressurized ink). Selected drops are separated from the ink in the nozzle by contact with the print medium or a transfer roller.	Very simple print head fabrication can be used The drop selection means does not need to provide the energy required to separate the drop from the nozzle	Requires close proximity between the print head and the print media or transfer roller May require two print heads printing alternate rows of the image Monolithic color print heads are difficult	Silverbrook, EP 0771 658 A2 and related patent applications Tone-Jet
Electrostatic pull on ink	The drops to be printed are selected by some manner (e.g. thermally induced surface tension reduction of pressurized ink). Selected drops are separated from the ink in the nozzle by a strong electric field.	Very simple print head fabrication can be used The drop selection means does not need to provide the energy required to separate the drop from the nozzle	Requires very high electrostatic field Electrostatic field for small nozzle sizes is above air breakdown Electrostatic field may attract dust	Silverbrook, EP 0771 658 A2 and related patent applications Tone-Jet
Magnetic pull on ink	The drops to be printed are selected by some manner (e.g. thermally induced surface tension reduction of pressurized ink). Selected drops are separated from the ink in the nozzle by a strong magnetic field acting on the magnetic ink.	Very simple print head fabrication can be used The drop selection means does not need to provide the energy required to separate the drop from the nozzle	Requires magnetic ink Ink colors other than black are difficult Requires very high magnetic fields	Silverbrook, EP 0771 658 A2 and related patent applications
Shutter	The actuator moves a shutter to block ink flow to the nozzle. The	High speed (>50 KHz) operation can be achieved	Moving parts are required Requires ink pressure modulator	IJ13, IJ17, IJ21

-continued

Operational mode	Description	Advantages	Disadvantages	Examples
	ink pressure is pulsed at a multiple of the drop ejection frequency.	due to reduced refill time Drop timing can be very accurate The actuator energy can be very low	Friction and wear must be considered Stiction is possible	
Shuttered grill	The actuator moves a shutter to block ink flow through a grill to the nozzle. The shutter movement need only be equal to the width of the grill holes.	Actuators with small travel can be used Actuators with small force can be used High speed (>50 KHz) operation can be achieved	Moving parts are required Requires ink pressure modulator Friction and wear must be considered Stiction is possible	IJ08, IJ15, IJ18, IJ19
Pulsed magnetic pull on ink pusher	A pulsed magnetic field attracts an 'ink pusher' at the drop ejection frequency. An actuator controls a catch, which prevents the ink pusher from moving when a drop is not to be ejected.	Extremely low energy operation is possible No heat dissipation problems	Requires an external pulsed magnetic field Requires special materials for both the actuator and the ink pusher Complex construction	IJ10

Auxiliary Mechanism (Applied to all Nozzles)

[0082]

Auxiliary Mechanism	Description	Advantages	Disadvantages	Examples
None	The actuator directly fires the ink drop, and there is no external field or other mechanism required.	Simplicity of construction Simplicity of operation Small physical size	Drop ejection energy must be supplied by individual nozzle actuator	Most inkjets, including piezoelectric and thermal bubble. IJ01-IJ07, IJ09, IJ11 IJ12, IJ14, IJ20, IJ22 IJ23-IJ45
Oscillating ink pressure (including acoustic stimulation)	The ink pressure oscillates, providing much of the drop ejection energy. The actuator selects which drops are to be fired by selectively blocking or enabling nozzles. The ink pressure oscillation may be achieved by vibrating the print head, or preferably by an actuator in the ink supply.	Oscillating ink pressure can provide a refill pulse, allowing higher operating speed The actuators may operate with much lower energy Acoustic lenses can be used to focus the sound on the nozzles	Requires external ink pressure oscillator Ink pressure phase and amplitude must be carefully controlled Acoustic reflections in the ink chamber must be designed for	Silverbrook, EP 0771 658 A2 and related patent applications IJ08, IJ13, IJ15, IJ17 IJ18, IJ19, IJ21
Media proximity	The print head is placed in close proximity to the print medium. Selected drops protrude from the print head further than unselected drops, and contact the print medium. The drop soaks into the medium fast enough to cause drop separation.	Low power High accuracy Simple print head construction	Precision assembly required Paper fibers may cause problems Cannot print on rough substrates	Silverbrook, EP 0771 658 A2 and related patent applications
Transfer roller	Drops are printed to a transfer roller instead of straight to the print medium. A transfer roller can also be used for proximity drop separation.	High accuracy Wide range of print substrates can be used Ink can be dried on the transfer roller	Bulky Expensive Complex construction	Silverbrook, EP 0771 658 A2 and related patent applications Tektronix hot melt piezoelectric inkjet Any of the IJ series Silverbrook, EP 0771 658 A2 and related patent applications
Electrostatic	An electric field is used to accelerate selected drops towards the print medium.	Low power Simple print head construction	Field strength required for separation of small drops is near or above air breakdown	Tone-Jet Silverbrook, EP 0771 658 A2 and related patent applications
Direct magnetic field	A magnetic field is used to accelerate selected drops of magnetic ink towards the print medium.	Low power Simple print head construction	Requires magnetic ink Requires strong magnetic field	Silverbrook, EP 0771 658 A2 and related patent applications
Cross magnetic field	The print head is placed in a constant magnetic field. The Lorentz force in a current carrying wire is used to move the actuator.	Does not require magnetic materials to be integrated in the print head manufacturing process	Requires external magnet Current densities may be high, resulting in electromigration problems	IJ06, IJ16

-continued

Auxiliary Mechanism	Description	Advantages	Disadvantages	Examples
Pulsed magnetic field	A pulsed magnetic field is used to cyclically attract a paddle, which pushes on the ink. A small actuator moves a catch, which selectively prevents the paddle from moving.	Very low power operation is possible Small print head size	Complex print head construction Magnetic materials required in print head	IJ10

Actuator Amplification or Modification Method [0083]

Actuator amplification	Description	Advantages	Disadvantages	Examples
None	No actuator mechanical amplification is used. The actuator directly drives the drop ejection process.	Operational simplicity	Many actuator mechanisms have insufficient travel, or insufficient force, to efficiently drive the drop ejection process	Thermal Bubble Inkjet IJ01, IJ02, IJ06, IJ07 IJ16, IJ25, IJ26
Differential expansion bend actuator	An actuator material expands more on one side than on the other. The expansion may be thermal, piezoelectric, magnetostrictive, or other mechanism.	Provides greater travel in a reduced print head area The bend actuator converts a high force low travel actuator mechanism to high travel, lower force mechanism.	High stresses are involved Care must be taken that the materials do not delaminate Residual bend resulting from high temperature or high stress during formation	Piezoelectric IJ03, IJ09, IJ17-IJ24 IJ27, IJ29-IJ39, IJ42, IJ43, IJ44
Transient bend actuator	A trilayer bend actuator where the two outside layers are identical. This cancels bend due to ambient temperature and residual stress. The actuator only responds to transient heating of one side or the other.	Very good temperature stability High speed, as a new drop can be fired before heat dissipates Cancels residual stress of formation	High stresses are involved Care must be taken that the materials do not delaminate	IJ40, IJ41
Actuator stack	A series of thin actuators are stacked. This can be appropriate where actuators require high electric field strength, such as electrostatic and piezoelectric actuators.	Increased travel Reduced drive voltage	Increased fabrication complexity Increased possibility of short circuits due to pinholes	Some piezoelectric ink jets IJ04
Multiple actuators	Multiple smaller actuators are used simultaneously to move the ink. Each actuator need provide only a portion of the force required.	Increases the force available from an actuator Multiple actuators can be positioned to control ink flow accurately	Actuator forces may not add linearly, reducing efficiency	IJ12, IJ13, IJ18, IJ20 IJ22, IJ28, IJ42, IJ43
Linear Spring	A linear spring is used to transform a motion with small travel and high force into a longer travel, lower force motion.	Matches low travel actuator with higher travel requirements Non-contact method of motion transformation	Requires print head area for the spring	IJ15
Reverse spring	The actuator loads a spring. When the actuator is turned off, the spring releases. This can reverse the force/distance curve of the actuator to make it compatible with the force/time requirements of the drop ejection.	Better coupling to the ink	Fabrication complexity High stress in the spring	IJ05, IJ11
Coiled actuator	A bend actuator is coiled to provide greater travel in a reduced chip area.	Increases travel Reduces chip area Planar implementations are relatively easy to fabricate.	Generally restricted to planar implementations due to extreme fabrication difficulty in other orientations.	IJ17, IJ21, IJ34, IJ35
Flexure bend actuator	A bend actuator has a small region near the fixture point, which flexes much more readily than the remainder of the actuator. The actuator flexing is effectively converted from an even coiling to an angular bend, resulting in greater travel of the actuator tip.	Simple means of increasing travel of a bend actuator	Care must be taken not to exceed the elastic limit in the flexure area Stress distribution is very uneven Difficult to accurately model with finite element analysis	IJ10, IJ19, IJ33

-continued

Actuator amplification	Description	Advantages	Disadvantages	Examples
Gears	Gears can be used to increase travel at the expense of duration. Circular gears, rack and pinion, ratchets, and other gearing methods can be used.	Low force, low travel actuators can be used Can be fabricated using standard surface MEMS processes	Moving parts are required Several actuator cycles are required More complex drive electronics Complex construction Friction, friction, and wear are possible	IJ13
Catch	The actuator controls a small catch. The catch either enables or disables movement of an ink pusher that is controlled in a bulk manner.	Very low actuator energy Very small actuator size	Complex construction Requires external force Unsuitable for pigmented inks	IJ10
Buckle plate	A buckle plate can be used to change a slow actuator into a fast motion. It can also convert a high force, low travel actuator into a high travel, medium force motion.	Very fast movement achievable	Must stay within elastic limits of the materials for long device life High stresses involved Generally high power requirement	S. Hirata et al, "An Ink-jet Head . . .", Proc. IEEE MEMS, February 1996, pp 418-423. IJ18, IJ27
Tapered magnetic pole	A tapered magnetic pole can increase travel at the expense of force.	Linearizes the magnetic force/distance curve	Complex construction	IJ14
Lever	A lever and fulcrum is used to transform a motion with small travel and high force into a motion with longer travel and lower force. The lever can also reverse the direction of travel.	Matches low travel actuator with higher travel requirements Fulcrum area has no linear movement, and can be used for a fluid seal	High stress around the fulcrum	IJ32, IJ36, IJ37
Rotary impeller	The actuator is connected to a rotary impeller. A small angular deflection of the actuator results in a rotation of the impeller vanes, which push the ink against stationary vanes and out of the nozzle.	High mechanical advantage The ratio of force to travel of the actuator can be matched to the nozzle requirements by varying the number of impeller vanes	Complex construction Unsuitable for pigmented inks	IJ28
Acoustic lens	A refractive or diffractive (e.g. zone plate) acoustic lens is used to concentrate sound waves.	No moving parts	Large area required Only relevant for acoustic ink jets	1993 Hadimioglu et al, EUP 550,192 1993 Elrod et al, EUP 572,220
Sharp conductive point	A sharp point is used to concentrate an electrostatic field.	Simple construction	Difficult to fabricate using standard VLSI processes for a surface ejecting ink-jet Only relevant for electrostatic ink jets	Tone-jet

Actuator Motion

[0084]

Actuator motion	Description	Advantages	Disadvantages	Examples
Volume expansion	The volume of the actuator changes, pushing the ink in all directions.	Simple construction in the case of thermal ink jet	High energy is typically required to achieve volume expansion. This leads to thermal stress, cavitation, and kogation in thermal ink jet implementations	Hewlett-Packard Thermal Inkjet Canon Bubblejet
Linear, normal to chip surface	The actuator moves in a direction normal to the print head surface. The nozzle is typically in the line of movement.	Efficient coupling to ink drops ejected normal to the surface	High fabrication complexity may be required to achieve perpendicular motion	IJ01, IJ02, IJ04, IJ07 IJ11, IJ14
Linear, parallel to chip surface	The actuator moves parallel to the print head surface. Drop ejection may still be normal to the surface.	Suitable for planar fabrication	Fabrication complexity Friction Stiction	IJ12, IJ13, IJ15, IJ33, IJ34, IJ35, IJ36
Membrane push	An actuator with a high force but small area is used to push a stiff membrane that is in contact with the ink.	The effective area of the actuator becomes the membrane area	Fabrication complexity Actuator size Difficulty of integration in a VLSI process	1982 Howkins U.S. Pat. No. 4,459,601
Rotary	The actuator causes the rotation of some element, such a grill or impeller	Rotary levers may be used to increase travel Small chip area requirements	Device complexity May have friction at a pivot point	IJ05, IJ08, IJ13, IJ28

-continued

Actuator motion	Description	Advantages	Disadvantages	Examples
Bend	The actuator bends when energized. This may be due to differential thermal expansion, piezoelectric expansion, magnetostriction, or other form of relative dimensional change.	A very small change in dimensions can be converted to a large motion.	Requires the actuator to be made from at least two distinct layers, or to have a thermal difference across the actuator	1970 Kyser et al U.S. Pat. No. 3,946,398 1973 Stemme U.S. Pat. No. 3,747,120 IJ03, IJ09, IJ10, IJ19 IJ23, IJ24, IJ25, IJ29 IJ30, IJ31, IJ33, IJ34 IJ35 IJ06
Swivel	The actuator swivels around a central pivot. This motion is suitable where there are opposite forces applied to opposite sides of the paddle, e.g. Lorenz force.	Allows operation where the net linear force on the paddle is zero Small chip area requirements	Inefficient coupling to the ink motion	IJ06
Straighten	The actuator is normally bent, and straightens when energized.	Can be used with shape memory alloys where the austenitic phase is planar	Requires careful balance of stresses to ensure that the quiescent bend is accurate	IJ26, IJ32
Double bend	The actuator bends in one direction when one element is energized, and bends the other way when another element is energized.	One actuator can be used to power two nozzles. Reduced chip size. Not sensitive to ambient temperature	Difficult to make the drops ejected by both bend directions identical. A small efficiency loss compared to equivalent single bend actuators.	IJ36, IJ37, IJ38
Shear	Energizing the actuator causes a shear motion in the actuator material.	Can increase the effective travel of piezoelectric actuators	Not readily applicable to other actuator mechanisms	1985 Fishbeck U.S. Pat. No. 4,584,590
Radial constriction	The actuator squeezes an ink reservoir, forcing ink from a constricted nozzle.	Relatively easy to fabricate single nozzles from glass tubing as macroscopic structures	High force required Inefficient Difficult to integrate with VLSI processes	1970 Zoltan U.S. Pat. No. 3,683,212
Coil/uncoil	A coiled actuator uncoils or coils more tightly. The motion of the free end of the actuator ejects the ink.	Easy to fabricate as a planar VLSI process Small area required, therefore low cost	Difficult to fabricate for non-planar devices Poor out-of-plane stiffness	IJ17, IJ21, IJ34, IJ35
Bow	The actuator bows (or buckles) in the middle when energized.	Can increase the speed of travel Mechanically rigid	Maximum travel is constrained High force required	IJ16, IJ18, IJ27
Push-Pull	Two actuators control a shutter. One actuator pulls the shutter, and the other pushes it.	The structure is pinned at both ends, so has a high out-of-plane rigidity	Not readily suitable for inkjets which directly push the ink	IJ18
Curl inwards	A set of actuators curl inwards to reduce the volume of ink that they enclose.	Good fluid flow to the region behind the actuator increases efficiency	Design complexity	IJ20, IJ42
Curl outwards	A set of actuators curl outwards, pressurizing ink in a chamber surrounding the actuators, and expelling ink from a nozzle in the chamber.	Relatively simple construction	Relatively large chip area	IJ43
Iris	Multiple vanes enclose a volume of ink. These simultaneously rotate, reducing the volume between the vanes.	High efficiency Small chip area	High fabrication complexity Not suitable for pigmented inks	IJ22
Acoustic vibration	The actuator vibrates at a high frequency.	The actuator can be physically distant from the ink	Large area required for efficient operation at useful frequencies Acoustic coupling and crosstalk Complex drive circuitry Poor control of drop volume and position	1993 Hadimioglu et al, EUP 550,192 1993 Elrod et al, EUP 572,220
None	In various ink jet designs the actuator does not move.	No moving parts	Various other tradeoffs are required to eliminate moving parts	Silverbrook, EP 0771 658 A2 and related patent applications Tone-jet

Nozzle Refill Method [0085]

Nozzle refill method	Description	Advantages	Disadvantages	Examples
Surface tension	After the actuator is energized, it typically returns rapidly to its normal position. This rapid return sucks in air through the nozzle opening. The ink surface tension at the nozzle then exerts a small force restoring the meniscus to a minimum area.	Fabrication simplicity Operational simplicity	Low speed Surface tension force relatively small compared to actuator force Long refill time usually dominates the total repetition rate	Thermal inkjet Piezoelectric inkjet IJ01-IJ07, IJ10-IJ14 IJ16, IJ20, IJ22-IJ45
Shuttered oscillating ink pressure	Ink to the nozzle chamber is provided at a pressure that oscillates at twice the drop ejection frequency. When a drop is to be ejected, the shutter is opened for 3 half cycles: drop ejection, actuator return, and refill.	High speed Low actuator energy, as the actuator need only open or close the shutter, instead of ejecting the ink drop	Requires common ink pressure oscillator May not be suitable for pigmented inks	IJ08, IJ13, IJ15, IJ17 IJ18, IJ19, IJ21
Refill actuator	After the main actuator has ejected a drop a second (refill) actuator is energized. The refill actuator pushes ink into the nozzle chamber. The refill actuator returns slowly, to prevent its return from emptying the chamber again.	High speed, as the nozzle is actively refilled	Requires two independent actuators per nozzle	IJ09
Positive ink pressure	The ink is held a slight positive pressure. After the ink drop is ejected, the nozzle chamber fills quickly as surface tension and ink pressure both operate to refill the nozzle.	High refill rate, therefore a high drop repetition rate is possible	Surface spill must be prevented Highly hydrophobic print head surfaces are required	Silverbrook, EP 0771 658 A2 and related patent applications Alternative for: IJ01-IJ07, IJ10-IJ14 IJ16, IJ20, IJ22-IJ45

Method of Restricting Back-Flow Through Inlet [0086]

Inlet back-flow restriction method	Description	Advantages	Disadvantages	Examples
Long inlet channel	The ink inlet channel to the nozzle chamber is made long and relatively narrow, relying on viscous drag to reduce inlet back-flow.	Design simplicity Operational simplicity Reduces crosstalk	Restricts refill rate May result in a relatively large chip area Only partially effective	Thermal inkjet Piezoelectric inkjet IJ42, IJ43
Positive ink pressure	The ink is under a positive pressure, so that in the quiescent state some of the ink drop already protrudes from the nozzle. This reduces the pressure in the nozzle chamber which is required to eject a certain volume of ink. The reduction in chamber pressure results in a reduction in ink pushed out through the inlet.	Drop selection and separation forces can be reduced Fast refill time	Requires a method (such as a nozzle rim or effective hydrophobizing, or both) to prevent flooding of the ejection surface of the print head.	Silverbrook, EP 0771 658 A2 and related patent applications Possible operation of the following: IJ01-IJ07, IJ09-IJ12 IJ14, IJ16, IJ20, IJ22, IJ23-IJ34, IJ36-IJ41 IJ44
Baffle	One or more baffles are placed in the inlet ink flow. When the actuator is energized, the rapid ink movement creates eddies which restrict the flow through the inlet. The slower refill process is unrestricted, and does not result in eddies.	The refill rate is not as restricted as the long inlet method. Reduces crosstalk	Design complexity May increase fabrication complexity (e.g. Tektronix hot melt Piezoelectric print heads).	HP Thermal Ink Jet Tektronix piezoelectric ink jet

-continued

Inlet back-flow restriction method	Description	Advantages	Disadvantages	Examples
Flexible flap restricts inlet	In this method recently disclosed by Canon, the expanding actuator (bubble) pushes on a flexible flap that restricts the inlet.	Significantly reduces back-flow for edge-shooter thermal ink jet devices	Not applicable to most inkjet configurations Increased fabrication complexity Inelastic deformation of polymer flap results in creep over extended use	Canon
Inlet filter	A filter is located between the ink inlet and the nozzle chamber. The filter has a multitude of small holes or slots, restricting ink flow. The filter also removes particles which may block the nozzle.	Additional advantage of ink filtration Ink filter may be fabricated with no additional process steps	Restricts refill rate May result in complex construction	IJ04, IJ12, IJ24, IJ27 IJ29, IJ30
Small inlet compared to nozzle	The ink inlet channel to the nozzle chamber has a substantially smaller cross section than that of the nozzle, resulting in easier ink egress out of the nozzle than out of the inlet.	Design simplicity	Restricts refill rate May result in a relatively large chip area Only partially effective	IJ02, IJ37, IJ44
Inlet shutter	A secondary actuator controls the position of a shutter, closing off the ink inlet when the main actuator is energized.	Increases speed of the ink-jet print head operation	Requires separate refill actuator and drive circuit	IJ09
The inlet is located behind the ink-pushing surface	The method avoids the problem of inlet back-flow by arranging the ink-pushing surface of the actuator between the inlet and the nozzle.	Back-flow problem is eliminated	Requires careful design to minimize the negative pressure behind the paddle	IJ01, IJ03, IJ05, IJ06 IJ07, IJ10, IJ11, IJ14 IJ16, IJ22, IJ23, IJ25 IJ28, IJ31, IJ32, IJ33 IJ34, IJ35, IJ36, IJ39 IJ40, IJ41 IJ07, IJ20, IJ26, IJ38
Part of the actuator moves to shut off the inlet	The actuator and a wall of the ink chamber are arranged so that the motion of the actuator closes off the inlet.	Significant reductions in back-flow can be achieved Compact designs possible	Small increase in fabrication complexity	
Nozzle actuator does not result in ink back-flow	In some configurations of ink jet, there is no expansion or movement of an actuator which may cause ink back-flow through the inlet.	Ink back-flow problem is eliminated	None related to ink back-flow on actuation	Silverbrook, EP 0771 658 A2 and related patent applications Valve-jet Tone-jet IJ08, IJ13, IJ15, IJ17 IJ18, IJ19, IJ21

Nozzle Clearing Method

[0087]

Nozzle Clearing method	Description	Advantages	Disadvantages	Examples
Normal nozzle firing	All of the nozzles are fired periodically, before the ink has a chance to dry. When not in use the nozzles are sealed (capped) against air. The nozzle firing is usually performed during a special clearing cycle, after first moving the print head to a cleaning station.	No added complexity on the print head	May not be sufficient to displace dried ink	Most ink jet systems IJ01-IJ07, IJ09-IJ12 IJ14, IJ16, IJ20, IJ22 IJ23-IJ34, IJ36-IJ45
Extra power to ink heater	In systems which heat the ink, but do not boil it under normal situations, nozzle clearing can be achieved by over-powering the heater and boiling ink at the nozzle.	Can be highly effective if the heater is adjacent to the nozzle	Requires higher drive voltage for clearing May require larger drive transistors	Silverbrook, EP 0771 658 A2 and related patent applications

-continued

Nozzle Clearing method	Description	Advantages	Disadvantages	Examples
Rapid succession of actuator pulses	The actuator is fired in rapid succession. In some configurations, this may cause heat build-up at the nozzle which boils the ink, clearing the nozzle. In other situations, it may cause sufficient vibrations to dislodge clogged nozzles.	Does not require extra drive circuits on the print head Can be readily controlled and initiated by digital logic	Effectiveness depends substantially upon the configuration of the inkjet nozzle	May be used with: IJ01-IJ07, IJ09-IJ11 IJ14, IJ16, IJ20, IJ22 IJ23-IJ25, IJ27-IJ34 IJ36-IJ45
Extra power to ink pushing actuator	Where an actuator is not normally driven to the limit of its motion, nozzle clearing may be assisted by providing an enhanced drive signal to the actuator.	A simple solution where applicable	Not suitable where there is a hard limit to actuator movement	May be used with: IJ03, IJ09, IJ16, IJ20 IJ23, IJ24, IJ25, IJ27 IJ29, IJ30, IJ31, IJ32 IJ39, IJ40, IJ41, IJ42 IJ43, IJ44, IJ45
Acoustic resonance	An ultrasonic wave is applied to the ink chamber. This wave is of an appropriate amplitude and frequency to cause sufficient force at the nozzle to clear blockages. This is easiest to achieve if the ultrasonic wave is at a resonant frequency of the ink cavity.	A high nozzle clearing capability can be achieved May be implemented at very low cost in systems which already include acoustic actuators	High implementation cost if system does not already include an acoustic actuator	IJ08, IJ13, IJ15, IJ17 IJ18, IJ19, IJ21
Nozzle clearing plate	A microfabricated plate is pushed against the nozzles. The plate has a post for every nozzle. The array of posts	Can clear severely clogged nozzles	Accurate mechanical alignment is required Moving parts are required There is risk of damage to the nozzles Accurate fabrication is required	Silverbrook, EP 0771 658 A2 and related patent applications
Ink pressure pulse	The pressure of the ink is temporarily increased so that ink streams from all of the nozzles. This may be used in conjunction with actuator energizing.	May be effective where other methods cannot be used	Requires pressure pump or other pressure actuator Expensive Wasteful of ink	May be used with all IJ series ink jets
Print head wiper	A flexible 'blade' is wiped across the print head surface. The blade is usually fabricated from a flexible polymer, e.g. rubber or synthetic elastomer.	Effective for planar print head surfaces Low cost	Difficult to use if print head surface is non-planar or very fragile Requires mechanical parts Blade can wear out in high volume print systems Fabrication complexity	Many ink jet systems
Separate ink boiling heater	A separate heater is provided at the nozzle although the normal drop e-jection mechanism does not require it. The heaters do not require individual drive circuits, as many nozzles can be cleared simultaneously, and no imaging is required.	Can be effective where other nozzle clearing methods cannot be used Can be implemented at no additional cost in some inkjet configurations		Can be used with many IJ series ink jets

Nozzle Plate Construction

[0088]

Nozzle plate construction	Description	Advantages	Disadvantages	Examples
Electroformed nickel	A nozzle plate is separately fabricated from electroformed nickel, and bonded to the print head chip.	Fabrication simplicity	High temperatures and pressures are required to bond nozzle plate Minimum thickness constraints Differential thermal expansion	Hewlett Packard Thermal Inkjet
Laser ablated or drilled polymer	Individual nozzle holes are ablated by an intense UV laser in a nozzle plate, which is typically a polymer such as polyimide or polysulphone	No masks required Can be quite fast Some control over nozzle profile is possible Equipment required is relatively low cost	Each hole must be individually formed Special equipment required Slow where there are many thousands of nozzles per print head May produce thin burrs at exit holes	Canon Bubblejet 1988 Sercel et al., SPIE, Vol. 998 Excimer Beam Applications, pp. 76-83 1993 Watanabe et al., U.S. Pat. No. 5,208,604 K. Bean, IEEE Transactions on
Silicon micro-machined	A separate nozzle plate is micromachined from single	High accuracy is attainable	Two part construction High cost	

-continued

Nozzle plate construction	Description	Advantages	Disadvantages	Examples
	crystal silicon, and bonded to the print head wafer.		Requires precision alignment Nozzles may be clogged by adhesive	Electron Devices, Vol. ED-25, No. 10, 1978, pp 1185-1195 Xerox 1990 Hawkins et al., U.S. Pat. No. 4,899,181 1970 Zoltan U.S. Pat. No. 3,683,212
Glass capillaries	Fine glass capillaries are drawn from glass tubing. This method has been used for making individual nozzles, but is difficult to use for bulk manufacturing of print heads with thousands of nozzles.	No expensive equipment required Simple to make single nozzles	Very small nozzle sizes are difficult to form Not suited for mass production	1970 Zoltan U.S. Pat. No. 3,683,212
Monolithic, surface micro-machined using VLSI lithographic processes	The nozzle plate is deposited as a layer using standard VLSI deposition techniques. Nozzles are etched in the nozzle plate using VLSI lithography and etching.	High accuracy (<1 μm) Monolithic Low cost Existing processes can be used	Requires sacrificial layer under the nozzle plate to form the nozzle chamber Surface may be fragile to the touch	Silverbrook, EP 0771 658 A2 and related patent applications IJ01, IJ02, IJ04, IJ11 IJ12, IJ17, IJ18, IJ20 IJ22, IJ24, IJ27, IJ28 IJ29, IJ30, IJ31, IJ32 IJ33, IJ34, IJ36, IJ37 IJ38, IJ39, IJ40, IJ41 IJ42, IJ43, IJ44 IJ03, IJ05, IJ06, IJ07 IJ08, IJ09, IJ10, IJ13 IJ14, IJ15, IJ16, IJ19 IJ21, IJ23, IJ25, IJ26
Monolithic, etched through substrate	The nozzle plate is a buried etch stop in the wafer. Nozzle chambers are etched in the front of the wafer, and the wafer is thinned from the back side. Nozzles are then etched in the etch stop layer.	High accuracy (<1 μm) Monolithic Low cost No differential expansion	Requires long etch times Requires a support wafer	
No nozzle plate	Various methods have been tried to eliminate the nozzles entirely, to prevent nozzle clogging. These include thermal bubble mechanisms and acoustic lens mechanisms	No nozzles to become clogged	Difficult to control drop position accurately Crosstalk problems	Ricoh 1995 Sekiya et al U.S. Pat. No. 5,412,413 1993 Hadimioglu et al EUP 550,192 1993 Elrod et al EUP 572,220 IJ35
Trough	Each drop ejector has a trough through which a paddle moves. There is no nozzle plate.	Reduced manufacturing complexity Monolithic	Drop firing direction is sensitive to wicking.	
Nozzle slit instead of individual nozzles	The elimination of nozzle holes and replacement by a slit encompassing many actuator positions reduces nozzle clogging, but increases crosstalk due to ink surface waves	No nozzles to become clogged	Difficult to control drop position accurately Crosstalk problems	1989 Saito et al U.S. Pat. No. 4,799,068

Drop Ejection Direction [0089]

Ejection direction	Description	Advantages	Disadvantages	Examples
Edge ('edge shooter')	Ink flow is along the surface of the chip, and ink drops are ejected from the chip edge.	Simple construction No silicon etching required Good heat sinking via substrate Mechanically strong Ease of chip handling	Nozzles limited to edge High resolution is difficult Fast color printing requires one print head per color	Canon Bubblejet 1979 Endo et al GB patent 2,007,162 Xerox heater-in-pit 1990 Hawkins et al U.S. Pat. No. 4,899,181 Tone-jet Hewlett-Packard TIJ 1982 Vaught et al U.S. Pat. No. 4,490,728 IJ02, IJ11, IJ12, IJ20 IJ22
Surface ('roof shooter')	Ink flow is along the surface of the chip, and ink drops are ejected from the chip surface, normal to the plane of the chip.	No bulk silicon etching required Silicon can make an effective heat sink Mechanical strength	Maximum ink flow is severely restricted	
Through chip, forward ('up shooter')	Ink flow is through the chip, and ink drops are ejected from the front surface of the chip.	High ink flow Suitable for pagewidth print High nozzle packing density	Requires bulk silicon etching	Silverbrook, EP 0771 658 A2 and related patent applications

-continued

Ejection direction	Description	Advantages	Disadvantages	Examples
Through chip, reverse ('down shooter')	Ink flow is through the chip, and ink drops are ejected from the rear surface of the chip.	therefore low manufacturing cost High ink flow Suitable for pagewidth print High nozzle packing density therefore low manufacturing cost	Requires wafer thinning Requires special handling during manufacture	IJ04, IJ17, IJ18, IJ24 IJ27-IJ45 IJ01, IJ03, IJ05, IJ06 IJ07, IJ08, IJ09, IJ10 IJ13, IJ14, IJ15, IJ16 IJ19, IJ21, IJ23, IJ25 IJ26
Through actuator	Ink flow is through the actuator, which is not fabricated as part of the same substrate as the drive transistors.	Suitable for piezoelectric print heads	Pagewidth print heads require several thousand connections to drive circuits Cannot be manufactured in standard CMOS fabs Complex assembly required	Epson Stylus Tektronix hot melt piezoelectric ink jets

Ink Type [0090]

Ink type	Description	Advantages	Disadvantages	Examples
Aqueous, dye	Water based ink which typically contains: water, dye, surfactant, humectant, and biocide. Modern ink dyes have high water-fastness, light fastness	Environmentally friendly No odor	Slow drying Corrosive Bleeds on paper May strikethrough Cockles paper	Most existing inkjets All IJ series ink jets Silverbrook, EP 0771 658 A2 and related patent applications
Aqueous, pigment	Water based ink which typically contains: water, pigment, surfactant, humectant, and biocide. Pigments have an advantage in reduced bleed, wicking and strikethrough.	Environmentally friendly No odor Reduced bleed Reduced wicking Reduced strikethrough	Slow drying Corrosive Pigment may clog nozzles Pigment may clog actuator mechanisms Cockles paper	IJ02, IJ04, IJ21, IJ26 IJ27, IJ30 Silverbrook, EP 0771 658 A2 and related patent applications Piezoelectric ink-jets Thermal ink jets (with significant restrictions) All IJ series ink jets
Methyl Ethyl Ketone (MEK)	MEK is a highly volatile solvent used for industrial printing on difficult surfaces such as aluminum cans.	Very fast drying Prints on various substrates such as metals and plastics	Odorous Flammable	
Alcohol (ethanol, 2-butanol, and others)	Alcohol based inks can be used where the printer must operate at temperatures below the freezing point of water. An example of this is in-camera consumer photographic printing.	Fast drying Operates at sub-freezing temperatures Reduced paper cockle Low cost	Slight odor Flammable	All IJ series ink jets
Phase change (hot melt)	The ink is solid at room temperature, and is melted in the print head before jetting. Hot melt inks are usually wax based, with a melting point around 80° C. After jetting the ink freezes almost instantly upon contacting the print medium or a transfer roller.	No drying time-ink instantly freezes on the print medium Almost any print medium can be used No paper cockle occurs No wicking occurs No bleed occurs No strikethrough occurs	High viscosity Printed ink typically has a 'waxy' feel Printed pages may 'block' Ink temperature may be above the curie point of permanent magnets Ink heaters consume power Long warm-up time	Tektronix hot melt piezoelectric ink jets 1989 Nowak U.S. Pat. No. 4,820,346 All IJ series ink jets
Oil	Oil based inks are extensively used in offset printing. They have advantages in improved characteristics on paper (especially no wicking or cockle). Oil soluble dyes and pigments are required.	High solubility medium for some dyes Does not cockle paper Does not wick through paper	High viscosity: this is a significant limitation for use in inkjets, which usually require a low viscosity. Some short chain and multi-branched oils have a sufficiently low viscosity. Slow drying	All IJ series ink jets
Microemulsion	A microemulsion is a stable, self forming emulsion of oil, water, and surfactant. The characteristic drop size is less than 100 nm, and is determined by the preferred curvature of the surfactant.	Stops ink bleed High dye solubility Water, oil, and amphiphilic soluble dyes can be used Can stabilize pigment suspensions	Viscosity higher than water based ink Cost is slightly higher than water based ink High surfactant concentration required (around 5%)	All IJ series ink jets

Ink Jet Printing

[0091] A large number of new forms of ink jet printers have been developed to facilitate alternative ink jet technologies for the image processing and data distribution system. Various combinations of ink jet devices can be included in printer

devices incorporated as part of the present invention. Australian Provisional Patent Applications relating to these ink jets which are specifically incorporated by cross reference. The serial numbers of respective corresponding US patent applications are also provided for the sake of convenience.

Australian Provisional Number	Filing Date	Title	US Patent/Patent Application and Filing Date
PO8066	15-Jul-97	Image Creation Method and Apparatus (IJ01)	6,227,652 (Jul. 10, 1998)
PO8072	15-Jul-97	Image Creation Method and Apparatus (IJ02)	6,213,588 (Jul. 10, 1998)
PO8040	15-Jul-97	Image Creation Method and Apparatus (IJ03)	6,213,589 (Jul. 10, 1998)
PO8071	15-Jul-97	Image Creation Method and Apparatus (IJ04)	6,231,163 (Jul. 10, 1998)
PO8047	15-Jul-97	Image Creation Method and Apparatus (IJ05)	6,247,795 (Jul. 10, 1998)
PO8035	15-Jul-97	Image Creation Method and Apparatus (IJ06)	6,394,581 (Jul. 10, 1998)
PO8044	15-Jul-97	Image Creation Method and Apparatus (IJ07)	6,244,691 (Jul. 10, 1998)
PO8063	15-Jul-97	Image Creation Method and Apparatus (IJ08)	6,257,704 (Jul. 10, 1998)
PO8057	15-Jul-97	Image Creation Method and Apparatus (IJ09)	6,416,168 (Jul. 10, 1998)
PO8056	15-Jul-97	Image Creation Method and Apparatus (IJ10)	6,220,694 (Jul. 10, 1998)
PO8069	15-Jul-97	Image Creation Method and Apparatus (IJ11)	6,257,705 (Jul. 10, 1998)
PO8049	15-Jul-97	Image Creation Method and Apparatus (IJ12)	6,247,794 (Jul. 10, 1998)
PO8036	15-Jul-97	Image Creation Method and Apparatus (IJ13)	6,234,610 (Jul. 10, 1998)
PO8048	15-Jul-97	Image Creation Method and Apparatus (IJ14)	6,247,793 (Jul. 10, 1998)
PO8070	15-Jul-97	Image Creation Method and Apparatus (IJ15)	6,264,306 (Jul. 10, 1998)
PO8067	15-Jul-97	Image Creation Method and Apparatus (IJ16)	6,241,342 (Jul. 10, 1998)
PO8001	15-Jul-97	Image Creation Method and Apparatus (IJ17)	6,247,792 (Jul. 10, 1998)
PO8038	15-Jul-97	Image Creation Method and Apparatus (IJ18)	6,264,307 (Jul. 10, 1998)
PO8033	15-Jul-97	Image Creation Method and Apparatus (IJ19)	6,254,220 (Jul. 10, 1998)
PO8002	15-Jul-97	Image Creation Method and Apparatus (IJ20)	6,234,611 (Jul. 10, 1998)
PO8068	15-Jul-97	Image Creation Method and Apparatus (IJ21)	6,302,528 (Jul. 10, 1998)
PO8062	15-Jul-97	Image Creation Method and Apparatus (IJ22)	6,283,582 (Jul. 10, 1998)
PO8034	15-Jul-97	Image Creation Method and Apparatus (IJ23)	6,239,821 (Jul. 10, 1998)
PO8039	15-Jul-97	Image Creation Method and Apparatus (IJ24)	6,338,547 (Jul. 10, 1998)
PO8041	15-Jul-97	Image Creation Method and Apparatus (IJ25)	6,247,796 (Jul. 10, 1998)
PO8004	15-Jul-97	Image Creation Method and Apparatus (IJ26)	09/113,122 (Jul. 10, 1998)
PO8037	15-Jul-97	Image Creation Method and Apparatus (IJ27)	6,390,603 (Jul. 10, 1998)
PO8043	15-Jul-97	Image Creation Method and Apparatus (IJ28)	6,362,843 (Jul. 10, 1998)
PO8042	15-Jul-97	Image Creation Method and Apparatus (IJ29)	6,293,653 (Jul. 10, 1998)
PO8064	15-Jul-97	Image Creation Method and Apparatus (IJ30)	6,312,107 (Jul. 10, 1998)
PO9389	23-Sep-97	Image Creation Method and Apparatus (IJ31)	6,227,653 (Jul. 10, 1998)
PO9391	23-Sep-97	Image Creation Method and Apparatus (IJ32)	6,234,609 (Jul. 10, 1998)

-continued

Australian Provisional Number	Filing Date	Title	US Patent/Patent Application and Filing Date
PP0888	12-Dec-97	Image Creation Method and Apparatus (IJ33)	6,238,040 (Jul. 10, 1998)
PP0891	12-Dec-97	Image Creation Method and Apparatus (IJ34)	6,188,415 (Jul. 10, 1998)
PP0890	12-Dec-97	Image Creation Method and Apparatus (IJ35)	6,227,654 (Jul. 10, 1998)
PP0873	12-Dec-97	Image Creation Method and Apparatus (IJ36)	6,209,989 (Jul. 10, 1998)
PP0993	12-Dec-97	Image Creation Method and Apparatus (IJ37)	6,247,791 (Jul. 10, 1998)
PP0890	12-Dec-97	Image Creation Method and Apparatus (IJ38)	6,336,710 (Jul. 10, 1998)
PP1398	19-Jan-98	An Image Creation Method and Apparatus (IJ39)	6,217,153 (Jul. 10, 1998)
PP2592	25-Mar-98	An Image Creation Method and Apparatus (IJ40)	6,416,167 (Jul. 10, 1998)
PP2593	25-Mar-98	Image Creation Method and Apparatus (IJ41)	6,243,113 (Jul. 10, 1998)
PP3991	9-Jun-98	Image Creation Method and Apparatus (IJ42)	6,283,581 (Jul. 10, 1998)
PP3987	9-Jun-98	Image Creation Method and Apparatus (IJ43)	6,247,790 (Jul. 10, 1998)
PP3985	9-Jun-98	Image Creation Method and Apparatus (IJ44)	6,260,953 (Jul. 10, 1998)
PP3983	9-Jun-98	Image Creation Method and Apparatus (IJ45)	6,267,469 (Jul. 10, 1998)

Ink Jet Manufacturing

[0092] Further, the present application may utilize advanced semiconductor fabrication techniques in the construction of large arrays of ink jet printers. Suitable manufac-

turing techniques are described in the following Australian provisional patent specifications incorporated here by cross-reference. The serial numbers of respective corresponding US patent applications are also provided for the sake of convenience.

Australian Provisional Number	Filing Date	Title	US Patent/Patent Application and Filing Date
PO7935	15-Jul-97	A Method of Manufacture of an Image Creation Apparatus (IJM01)	6,224,780 (Jul. 10, 1998)
PO7936	15-Jul-97	A Method of Manufacture of an Image Creation Apparatus (IJM02)	6,235,212 (Jul. 10, 1998)
PO7937	15-Jul-97	A Method of Manufacture of an Image Creation Apparatus (IJM03)	6,280,643 (Jul. 10, 1998)
PO8061	15-Jul-97	A Method of Manufacture of an Image Creation Apparatus (IJM04)	6,284,147 (Jul. 10, 1998)
PO8054	15-Jul-97	A Method of Manufacture of an Image Creation Apparatus (IJM05)	6,214,244 (Jul. 10, 1998)
PO8065	15-Jul-97	A Method of Manufacture of an Image Creation Apparatus (IJM06)	6,071,750 (Jul. 10, 1998)
PO8055	15-Jul-97	A Method of Manufacture of an Image Creation Apparatus (IJM07)	6,267,905 (Jul. 10, 1998)
PO8053	15-Jul-97	A Method of Manufacture of an Image Creation Apparatus (IJM08)	6,251,298 (Jul. 10, 1998)
PO8078	15-Jul-97	A Method of Manufacture of an Image Creation Apparatus (IJM09)	6,258,285 (Jul. 10, 1998)
PO7933	15-Jul-97	A Method of Manufacture of an Image Creation Apparatus (IJM10)	6,225,138 (Jul. 10, 1998)
PO7950	15-Jul-97	A Method of Manufacture of an Image Creation Apparatus (IJM11)	6,241,904 (Jul. 10, 1998)
PO7949	15-Jul-97	A Method of Manufacture of an Image Creation Apparatus (IJM12)	6,299,786 (Jul. 10, 1998)
PO8060	15-Jul-97	A Method of Manufacture of an Image Creation Apparatus (IJM13)	09/113,124 (Jul. 10, 1998)
PO8059	15-Jul-97	A Method of Manufacture of an Image Creation Apparatus (IJM14)	6,231,773 (Jul. 10, 1998)

-continued

Australian Provisional Number	Filing Date	Title	US Patent/Patent Application and Filing Date
PO8073	15-Jul-97	A Method of Manufacture of an Image Creation Apparatus (IJM15)	6,190,931 (Jul. 10, 1998)
PO8076	15-Jul-97	A Method of Manufacture of an Image Creation Apparatus (IJM16)	6,248,249 (Jul. 10, 1998)
PO8075	15-Jul-97	A Method of Manufacture of an Image Creation Apparatus (IJM17)	6,290,862 (Jul. 10, 1998)
PO8079	15-Jul-97	A Method of Manufacture of an Image Creation Apparatus (IJM18)	6,241,906 (Jul. 10, 1998)
PO8050	15-Jul-97	A Method of Manufacture of an Image Creation Apparatus (IJM19)	09/113,116 (Jul. 10, 1998)
PO8052	15-Jul-97	A Method of Manufacture of an Image Creation Apparatus (IJM20)	6,241,905 (Jul. 10, 1998)
PO7948	15-Jul-97	A Method of Manufacture of an Image Creation Apparatus (IJM21)	6,451,216 (Jul. 10, 1998)
PO7951	15-Jul-97	A Method of Manufacture of an Image Creation Apparatus (IJM22)	6,231,772 (Jul. 10, 1998)
PO8074	15-Jul-97	A Method of Manufacture of an Image Creation Apparatus (IJM23)	6,274,056 (Jul. 10, 1998)
PO7941	15-Jul-97	A Method of Manufacture of an Image Creation Apparatus (IJM24)	6,290,861 (Jul. 10, 1998)
PO8077	15-Jul-97	A Method of Manufacture of an Image Creation Apparatus (IJM25)	6,248,248 (Jul. 10, 1998)
PO8058	15-Jul-97	A Method of Manufacture of an Image Creation Apparatus (IJM26)	6,306,671 (Jul. 10, 1998)
PO8051	15-Jul-97	A Method of Manufacture of an Image Creation Apparatus (IJM27)	6,331,258 (Jul. 10, 1998)
PO8045	15-Jul-97	A Method of Manufacture of an Image Creation Apparatus (IJM28)	6,110,754 (Jul. 10, 1998)
PO7952	15-Jul-97	A Method of Manufacture of an Image Creation Apparatus (IJM29)	6,294,101 (Jul. 10, 1998)
PO8046	15-Jul-97	A Method of Manufacture of an Image Creation Apparatus (IJM30)	6,416,679 (Jul. 10, 1998)
PO8503	11-Aug-97	A Method of Manufacture of an Image Creation Apparatus (IJM30a)	6,264,849 (Jul. 10, 1998)
PO9390	23-Sep-97	A Method of Manufacture of an Image Creation Apparatus (IJM31)	6,254,793 (Jul. 10, 1998)
PO9392	23-Sep-97	A Method of Manufacture of an Image Creation Apparatus (IJM32)	6,235,211 (Jul. 10, 1998)
PP0889	12-Dec-97	A Method of Manufacture of an Image Creation Apparatus (IJM35)	6,235,211 (Jul. 10, 1998)
PP0887	12-Dec-97	A Method of Manufacture of an Image Creation Apparatus (IJM36)	6,264,850 (Jul. 10, 1998)
PP0882	12-Dec-97	A Method of Manufacture of an Image Creation Apparatus (IJM37)	6,258,284 (Jul. 10, 1998)
PP0874	12-Dec-97	A Method of Manufacture of an Image Creation Apparatus (IJM38)	6,258,284 (Jul. 10, 1998)
PP1396	19-Jan-98	A Method of Manufacture of an Image Creation Apparatus (IJM39)	6,228,668 (Jul. 10, 1998)
PP2591	25-Mar-98	A Method of Manufacture of an Image Creation Apparatus (IJM41)	6,180,427 (Jul. 10, 1998)
PP3989	9-Jun-98	A Method of Manufacture of an Image Creation Apparatus (IJM40)	6,171,875 (Jul. 10, 1998)
PP3990	9-Jun-98	A Method of Manufacture of an Image Creation Apparatus (IJM42)	6,267,904 (Jul. 10, 1998)
PP3986	9-Jun-98	A Method of Manufacture of an Image Creation Apparatus (IJM43)	6,245,247 (Jul. 10, 1998)
PP3984	9-Jun-98	A Method of Manufacture of an Image Creation Apparatus (IJM44)	6,245,247 (Jul. 10, 1998)
PP3982	9-Jun-98	A Method of Manufacture of an Image Creation Apparatus (IJM45)	6,231,148 (Jul. 10, 1998)

Fluid Supply

[0093] Further, the present application may utilize an ink delivery system to the ink jet head. Delivery systems relating to the supply of ink to a series of ink jet nozzles are described

in the following Australian provisional patent specifications, the disclosure of which are hereby incorporated by cross-reference. The serial numbers of respective corresponding US patent applications are also provided for the sake of convenience.

-continued

Australian Provisional Number	Filing Date	Title	US Patent/Patent Application and Filing Date
PO8003	15-Jul-97	Supply Method and Apparatus (F1)	6,350,023 (Jul. 10, 1998)
PO8005	15-Jul-97	Supply Method and Apparatus (F2)	6,318,849 (Jul. 10, 1998)
PO9404	23-Sep-97	A Device and Method (F3)	09/113,101 (Jul. 10, 1998)

MEMS Technology

[0094] Further, the present application may utilize advanced semiconductor microelectromechanical techniques in the construction of large arrays of ink jet printers. Suitable microelectromechanical techniques are described in the following Australian provisional patent specifications incorporated here by cross-reference. The serial numbers of respective corresponding US patent applications are also provided for the sake of convenience.

Australian Provisional Number	Filing Date	Title	US Patent/Patent Application and Filing Date
PO7943	15-Jul-97	A device (MEMS01)	
PO8006	15-Jul-97	A device (MEMS02)	6,087,638 (Jul. 10, 1998)

Australian Provisional Number	Filing Date	Title	US Patent/Patent Application and Filing Date
PO8007	15-Jul-97	A device (MEMS03)	09/113,093 (Jul. 10, 1998)
PO8008	15-Jul-97	A device (MEMS04)	6,340,222 (Jul. 10, 1998)
PO8010	15-Jul-97	A device (MEMS05)	6,041,600 (Jul. 10, 1998)
PO8011	15-Jul-97	A device (MEMS06)	6,299,300 (Jul. 10, 1998)
PO7947	15-Jul-97	A device (MEMS07)	6,067,797 (Jul. 10, 1998)
PO7945	15-Jul-97	A device (MEMS08)	09/113,081 (Jul. 10, 1998)
PO7944	15-Jul-97	A device (MEMS09)	6,286,935 (Jul. 10, 1998)
PO7946	15-Jul-97	A device (MEMS10)	6,044,646 (Jul. 10, 1998)
PO9393	23-Sep-97	A Device and Method (MEMS11)	09/113,065 (Jul. 10, 1998)
PP0875	12-Dec-97	A Device (MEMS12)	09/113,078 (Jul. 10, 1998)
PP0894	12-Dec-97	A Device and Method (MEMS13)	09/113,075 (Jul. 10, 1998)

IR Technologies

[0095] Further, the present application may include the utilization of a disposable camera system such as those described in the following Australian provisional patent specifications incorporated here by cross-reference. The serial numbers of respective corresponding US patent applications are also provided for the sake of convenience.

Australian Provisional Number	Filing Date	Title	US Patent/Patent Application and Filing Date
PP0895	12-Dec-97	An Image Creation Method and Apparatus (IR01)	6,231,148 (Jul. 10, 1998)
PP0870	12-Dec-97	A Device and Method (IR02)	09/113,106 (Jul. 10, 1998)
PP0869	12-Dec-97	A Device and Method (IR04)	6,293,658 (Jul. 10, 1998)
PP0887	12-Dec-97	Image Creation Method and Apparatus (IR05)	09/113,104 (Jul. 10, 1998)
PP0885	12-Dec-97	An Image Production System (IR06)	6,238,033 (Jul. 10, 1998)
PP0884	12-Dec-97	Image Creation Method and Apparatus (IR10)	6,312,070 (Jul. 10, 1998)
PP0886	12-Dec-97	Image Creation Method and Apparatus (IR12)	6,238,111 (Jul. 10, 1998)
PP0871	12-Dec-97	A Device and Method (IR13)	09/113,086 (Jul. 10, 1998)
PP0876	12-Dec-97	An Image Processing Method and Apparatus (IR14)	09/113,094 (Jul. 10, 1998)
PP0877	12-Dec-97	A Device and Method (IR16)	6,378,970 (Jul. 10, 1998)
PP0878	12-Dec-97	A Device and Method (IR17)	6,196,739 (Jul. 10, 1998)
PP0879	12-Dec-97	A Device and Method (IR18)	09/112,774 (Jul. 10, 1998)
PP0883	12-Dec-97	A Device and Method (IR19)	6,270,182 (Jul. 10, 1998)
PP0880	12-Dec-97	A Device and Method (IR20)	6,152,619 (Jul. 10, 1998)
PP0881	12-Dec-97	A Device and Method (IR21)	09/113,092 (Jul. 10, 1998)

DotCard Technologies

[0096] Further, the present application may include the utilization of a data distribution system such as that described in the following Australian provisional patent specifications incorporated here by cross-reference. The serial numbers of respective corresponding US patent applications are also provided for the sake of convenience.

Australian Provisional Number	Filing Date	Title	US Patent/Patent Application and Filing Date
PP2370	16-Mar-98	Data Processing Method and Apparatus (Dot01)	09/112,781 (Jul. 10, 1998)

-continued

Australian Provisional Number	Filing Date	Title	US Patent/Patent Application and Filing Date
PP2371	16-Mar-98	Data Processing Method and Apparatus (Dot02)	09/113,052 (Jul. 10, 1998)

Artcam Technologies

[0097] Further, the present application may include the utilization of camera and data processing techniques such as an Artcam type device as described in the following Australian provisional patent specifications incorporated here by cross-reference. The serial numbers of respective corresponding US patent applications are also provided for the sake of convenience.

Australian Provisional Number	Filing Date	Title	US Patent/Patent Application and Filing Date
PO7991	15-Jul-97	Image Processing Method and Apparatus (ART01)	09/113,060 (Jul. 10, 1998)
PO7988	15-Jul-97	Image Processing Method and Apparatus (ART02)	6,476,863 (Jul. 10, 1998)
PO7993	15-Jul-97	Image Processing Method and Apparatus (ART03)	09/113,073 (Jul. 10, 1998)
PO9395	23-Sep-97	Data Processing Method and Apparatus (ART04)	6,322,181 (Jul. 10, 1998)
PO8017	15-Jul-97	Image Processing Method and Apparatus (ART06)	09/112,747 (Jul. 10, 1998)
PO8014	15-Jul-97	Media Device (ART07)	6,227,648 (Jul. 10, 1998)
PO8025	15-Jul-97	Image Processing Method and Apparatus (ART08)	09/112,750 (Jul. 10, 1998)
PO8032	15-Jul-97	Image Processing Method and Apparatus (ART09)	09/112,746 (Jul. 10, 1998)
PO7999	15-Jul-97	Image Processing Method and Apparatus (ART10)	09/112,743 (Jul. 10, 1998)
PO7998	15-Jul-97	Image Processing Method and Apparatus (ART11)	09/112,742 (Jul. 10, 1998)
PO8031	15-Jul-97	Image Processing Method and Apparatus (ART12)	09/112,741 (Jul. 10, 1998)
PO8030	15-Jul-97	Media Device (ART13)	6,196,541 (Jul. 10, 1998)
PO7997	15-Jul-97	Media Device (ART15)	6,195,150 (Jul. 10, 1998)
PO7979	15-Jul-97	Media Device (ART16)	6,362,868 (Jul. 10, 1998)
PO8015	15-Jul-97	Media Device (ART17)	09/112,738 (Jul. 10, 1998)
PO7978	15-Jul-97	Media Device (ART18)	09/113,067 (Jul. 10, 1998)
PO7982	15-Jul-97	Data Processing Method and Apparatus (ART19)	6,431,669 (Jul. 10, 1998)
PO7989	15-Jul-97	Data Processing Method and Apparatus (ART20)	6,362,869 (Jul. 10, 1998)
PO8019	15-Jul-97	Media Processing Method and Apparatus (ART21)	6,472,052 (Jul. 10, 1998)
PO7980	15-Jul-97	Image Processing Method and Apparatus (ART22)	6,356,715 (Jul. 10, 1998)
PO8018	15-Jul-97	Image Processing Method and Apparatus (ART24)	09/112,777 (Jul. 10, 1998)
PO7938	15-Jul-97	Image Processing Method and Apparatus (ART25)	09/113,224 (Jul. 10, 1998)
PO8016	15-Jul-97	Image Processing Method and Apparatus (ART26)	6,366,693 (Jul. 10, 1998)
PO8024	15-Jul-97	Image Processing Method and Apparatus (ART27)	6,329,990 (Jul. 10, 1998)

-continued

Australian Provisional Number	Filing Date	Title	US Patent/Patent Application and Filing Date
PO7940	15-Jul-97	Data Processing Method and Apparatus (ART28)	09/113,072 (Jul. 10, 1998)
PO7939	15-Jul-97	Data Processing Method and Apparatus (ART29)	09/112,785 (Jul. 10, 1998)
PO8501	11-Aug-97	Image Processing Method and Apparatus (ART30)	6,137,500 (Jul. 10, 1998)
PO8500	11-Aug-97	Image Processing Method and Apparatus (ART31)	09/112,796 (Jul. 10, 1998)
PO7987	15-Jul-97	Data Processing Method and Apparatus (ART32)	09/113,071 (Jul. 10, 1998)
PO8022	15-Jul-97	Image Processing Method and Apparatus (ART33)	6,398,328 (Jul. 10, 1998)
PO8497	11-Aug-97	Image Processing Method and Apparatus (ART34)	09/113,090 (Jul. 10, 1998)
PO8020	15-Jul-97	Data Processing Method and Apparatus (ART38)	6,431,704 (Jul. 10, 1998)
PO8023	15-Jul-97	Data Processing Method and Apparatus (ART39)	09/113,222 (Jul. 10, 1998)
PO8504	11-Aug-97	Image Processing Method and Apparatus (ART42)	09/112,786 (Jul. 10, 1998)
PO8000	15-Jul-97	Data Processing Method and Apparatus (ART43)	6,415,054 (Jul. 10, 1998)
PO7977	15-Jul-97	Data Processing Method and Apparatus (ART44)	09/112,782 (Jul. 10, 1998)
PO7934	15-Jul-97	Data Processing Method and Apparatus (ART45)	09/113,056 (Jul. 10, 1998)
PO7990	15-Jul-97	Data Processing Method and Apparatus (ART46)	09/113,059 (Jul. 10, 1998)
PO8499	11-Aug-97	Image Processing Method and Apparatus (ART47)	6,486,886 (Jul. 10, 1998)
PO8502	11-Aug-97	Image Processing Method and Apparatus (ART48)	6,381,361 (Jul. 10, 1998)
PO7981	15-Jul-97	Data Processing Method and Apparatus (ART50)	6,317,192 (Jul. 10, 1998)
PO7986	15-Jul-97	Data Processing Method and Apparatus (ART51)	09/113,057 (Jul. 10, 1998)
PO7983	15-Jul-97	Data Processing Method and Apparatus (ART52)	09/113,054 (Jul. 10, 1998)
PO8026	15-Jul-97	Image Processing Method and Apparatus (ART53)	09/112,752 (Jul. 10, 1998)
PO8027	15-Jul-97	Image Processing Method and Apparatus (ART54)	09/112,759 (Jul. 10, 1998)
PO8028	15-Jul-97	Image Processing Method and Apparatus (ART56)	09/112,757 (Jul. 10, 1998)
PO9394	23-Sep-97	Image Processing Method and Apparatus (ART57)	6,357,135 (Jul. 10, 1998)
PO9396	23-Sep-97	Data Processing Method and Apparatus (ART58)	09/113,107 (Jul. 10, 1998)
PO9397	23-Sep-97	Data Processing Method and Apparatus (ART59)	6,271,931 (Jul. 10, 1998)
PO9398	23-Sep-97	Data Processing Method and Apparatus (ART60)	6,353,772 (Jul. 10, 1998)
PO9399	23-Sep-97	Data Processing Method and Apparatus (ART61)	6,106,147 (Jul. 10, 1998)
PO9400	23-Sep-97	Data Processing Method and Apparatus (ART62)	09/112,790 (Jul. 10, 1998)
PO9401	23-Sep-97	Data Processing Method and Apparatus (ART63)	6,304,291 (Jul. 10, 1998)
PO9402	23-Sep-97	Data Processing Method and Apparatus (ART64)	09/112,788 (Jul. 10, 1998)
PO9403	23-Sep-97	Data Processing Method and Apparatus (ART65)	6,305,770 (Jul. 10, 1998)
PO9405	23-Sep-97	Data Processing Method and Apparatus (ART66)	6,289,262 (Jul. 10, 1998)
PP0959	16-Dec-97	A Data Processing Method and Apparatus (ART68)	6,315,200 (Jul. 10, 1998)
PP1397	19-Jan-98	A Media Device (ART69)	6,217,165 (Jul. 10, 1998)

I claim:

1. A digital camera comprising:
an image sensor for capturing an image;
an image processor for processing image data from the image sensor to produce print data;
a printhead for printing the print data; and
a cartridge interface for receiving a cartridge having a supply of media substrates pre-printed with postcard formatting and a memory storing information relating to the dimensions of the postcard formatting,
wherein the image processor produces the print data in accordance with the stored information accessed via the cartridge interface to produce personalised postcards.
2. A digital camera according to claim 1 wherein the cartridge further comprises the ink supply for the printhead and the memory is an authentication chip that allows the image processor to confirm that the media substrate and the ink supplies are suitable for use with the camera.
3. A digital camera according to claim 1 wherein:
the image sensor comprises a charge coupled device (CCD) and an auto exposure setting for adjusting the

image data captured by the CCD in response to the lighting conditions at image capture; and
the image processor uses the auto exposure setting when processing the image data from the CCD.

4. A digital camera according to claim 3 wherein the image processor uses the auto exposure setting to determine a re-mapping of colour data within the image data from the CCD such that the printhead prints an amended image that takes account of the light conditions at image capture.

5. A digital camera according to claim 4 wherein the re-mapping of the colour data produces deeper and richer colours in the amended image when the light conditions at image capture are dim.

6. A digital camera according to claim 4 wherein the re-mapping of the colour data produces brighter and more saturated colours in the amended image when the light conditions at image capture are bright.

7. A digital camera according to claim 3 wherein the image processor uses the auto exposure setting to add exposure specific graphics to the printed image.

* * * * *