



⑪ Publication number : **0 220 132 B1**

⑫

EUROPEAN PATENT SPECIFICATION

⑬ Date of publication of patent specification :
06.03.91 Bulletin 91/10

⑭ Int. Cl.⁵ : **B65D 83/14**

⑮ Application number : **86810452.2**

⑯ Date of filing : **14.10.86**

⑰ **Time delayed total-release aerosol dispensers.**

⑲ Priority : **24.10.85 US 790925**

⑳ Date of publication of application :
29.04.87 Bulletin 87/18

㉑ Publication of the grant of the patent :
06.03.91 Bulletin 91/10

㉒ Designated Contracting States :
AT BE CH DE ES FR GB GR IT LI NL SE

㉓ References cited :
US-A- 3 399 806
US-A- 4 426 025

㉔ Proprietor : **SANDOZ AG**
Lichtstrasse 35
CH-4002 Basel (CH)
BE CH ES FR GB GR IT LI NL SE
Proprietor : **SANDOZ-PATENT-GMBH**
Humboldtstrasse 3
W-7850 Lörrach (DE)
DE
Proprietor : **SANDOZ-ERFINDUNGEN**
Verwaltungsgesellschaft m.b.H.
Brunner Strasse 59
A-1235 Wien (AT)
AT

㉕ Inventor : **Pearce, Robert C.**
3704 Palomino Drive
Arlington Texas 76017 (US)

EP 0 220 132 B1

Note : Within nine months from the publication of the mention of the grant of the European patent, any person may give notice to the European Patent Office of opposition to the European patent granted. Notice of opposition shall be filed in a written reasoned statement. It shall not be deemed to have been filed until the opposition fee has been paid (Art. 99(1) European patent convention).

Description

Devices which allow for the total or partial release of an active agent from an aerosol dispenser, as defined in the preamble of claim 1, are known. Examples of these devices may be found in the Handbook of Aerosol Technology by P.S. Sanders, 2nd Ed., page 85, Editor Krieger, 1979).

The main disadvantage of the total-release aerosol dispensers is their immediate actuation which exposes the operator to the contents of the containers.

Some attempts for delayed release of the content of various containers were made previously to prevent direct contact of the operator with the content of the container. The resulting devices are mostly applicable and/or suitable for specific purpose only.

Dispensers with delayed opening of a water soluble seal which dissolves when coming in contact with water in the washing machine are described in USP 3,399,806. USP 3,800,878 describes a fire extinguisher utilizing an eutectic material in conjunction with an auxiliary seal that isolates the eutectic material from the pressurized fluid of the container. The eutectic material melts in response to an increase in ambient temperature. After complete melting of the eutectic material the auxiliary seal is opened by the pressure within the container thereby permitting release of the fluid. It is rather dangerous to employ together such actuation stimuli as heat and pressure because the heat increases the pressure in the container which may explode.

US-A- 2 759 768 discloses a seal that can be removed by the pressure of the container contents. The seal as defined in US-A 2,759,768 requires a solvent capable of dissolving the seal before the pressurized contents of the container can remove the seal. As depicted in Figures 1 and 2 of this patent, the seal is in constant contact with the contents of the container and is not removed until it is softened by a solvent which is kept external to the container contents. There is no "valve" separating the contents of the container from the seal in the embodiments described in US-A 2,759,768.

The present invention is defined by independent claim 1, which is directed to a continuous aerosol dispenser, and by independent claim 11, which is directed to a method for delaying the release at the contents of a continuous aerosol dispenser.

The present invention provides a simple, inexpensive, effective, practical and easy to handle means for delayed actuation. It is generally applicable and independent from external factors such as aqueous medium or heat. It provides a time delayed release for all kinds of total-release aerosol dispensers such as foggers, fumigators, insecticidal sprays and bombs, paint capsules, gas bombs, aerosols, oven cleaners, tear gas grenades, smoke grenades and explosives, and is particularly appropriate for distribution of pesticides, more particularly of insecticides.

The time delayed release of the aerosol dispenser of the invention is obtained with the aid of a material sealing the exit conduit of the dispenser and which material is susceptible to removal by the content of the dispenser's container. The sealing material is removed, with delay over a predeterminable period of time, by the contents of the container upon mechanical actuation of the valve.

The sealing material may be in removable association with the valve, valve stem or actuator of said dispenser. After removal of the sealing material the content of the container is released.

The removal of sealing material is obtained through the pressure executed by the contents of the dispenser on the sealing material after actuation of the valve. To facilitate removal, the sealing material may be optionally dissolved in, and/or disintegrated by the contents of the container after actuation of the valve.

A wide variety of valves, valve stems, actuators and containers of total-release aerosol dispensers are known. Essentially all such dispensers may be adapted in accordance with the present invention.

In a preferred embodiment of the invention, the actuator is in the form of a so-called "overcap". Overcaps have the dual function of protecting the valve of an aerosol dispenser during storage and of actuating said valve, when inverted and remounted onto the dispenser (see USP 4 426 025).

The sealing material can be any material which can be placed in the conduit or on the orifice of the valve, valve stem, the actuator or between them and can be removed after actuation of the valve under the influence of the container's content.

Suitable sealing material may be any material removable under the pressure of the container's content after actuation and may for example be in foil form or have a soft plastic consistency.

Examples of sealing materials suitable for use in the present invention are adhesive or insulation tapes, e.g. tapes known under the trade names Scotch® 810, Scotch® CW 715 44AAV 4152, R- Tape® (CP-PAN) and Silver Cloth® Tape, preferably Scotch® 810 or Silver Cloth® Tape; polyolefins and natural and synthetic resins such as polyvinylchloride, polypropylene, ethylene ethyl acrylates, ethylene vinyl acetate, polyvinyl acetate, polyvinyl alcohol, butyl acrylate, rubbers and elastomers, polyisoprene, polystyrene, polyvinyl acetal, polyvinyl ethyl ether, polyethylene and similar materials, e.g. low density polyethylene foils formulated with paraffin wax, such as the laboratory films available from American Can Corp. under the trade

name Parafilm®, preferably such films of 0.010 to 0.015 inches thickness ; sealants ; greases such as silicone grease ; waxes.

The natural and synthetic resins may either be used alone or may be, and preferably are, employed in combination with a plasticizer and optionally other formulating agents such as dyes.

5 Sealing materials particularly suitable for use in the present invention are selected from adhesive or insulation tapes, laboratory films such as those known as Parafilm®, and natural or synthetic resins (such as rubbers, polyisoprenes or other aliphatic hydrocarbon resins, wood resins and the like).

10 Examples of resins particularly suitable for use as sealing agent are wood resins, e.g. wood resins having a softening point of more than 85°C, e.g. in the range of 90 to 105°C, such as low molecular weight aliphatic hydrocarbon resins derived mainly from dienes and other reactive olefin monomers, e.g. those known under the trade name Piccopale® resins (particularly Piccopale® 100-SF, available from Hercules Inc., Wilmington) ; and ethylene vinyl acetate (EVA) based resins, such as the EVA-wax-resin compositions known as Nevtac® resins (available from Neville Chemical Company), e.g. Nevtac® 100 and Super Nevtac® 99.

15 Examples of plasticizers suitable for use in the resin combinations are phthalates and adipates, e.g. dibutyl phthalate, dicyclohexylphthalate, diethyl phthalate, dilauroylphthalate, dimethyl phthalate, diphenyl phthalate, dioctyl phthalate, dioctyl adipate, butyl benzyl phthalate, diundecyl phthalate, the dialkyl phthalate known under the trade name Santicizer® 711, the dialkyl adipate known under the trade name Santicizer® 97 and polymeric type plasticizers such as Santicizer® 261, 409, 411, 412, 429, 480, 481, 482, 20 334 F, 79TM-trimellitate type, particularly suitable plasticizers are dioctyl phthalate (DOP), butyl benzyl phthalate (Santicizer® 160 ; BBP) and dioctyl adipate (DOA).

The most appropriate sealing materials for use in this invention are laboratory films such as those known as Parafilm® and referred to herein above, particularly such films having a thickness of 0.005-0.015, more preferably of 0.01-0.015 inches, and resin/plasticizer combinations mixed in a weight ratio from 50 : 50 to 25 90 : 10, preferably from 70 : 30 to 90 : 10. Particularly suitable resin/plasticizer combinations comprise from 75-85% by weight of resin and 15 to 25% by weight of plasticizer. They may additionally comprise formulating agents, e.g. 1 part for 100 parts resin/plasticizer combination. A preferred example of formulation comprises from 79-82% by weight of resin, 17-22% by weight of plasticizer, the balance being formulating agents such as dyes, e.g. fluorescent dyes such as fluorescent orange, fluorescent yellow, fluorescent blue, fluorescent 30 red and fluorescent black.

The sealing material can be placed at any place of the exit conduit allowing sealing of the terminal orifice of the aerosol dispenser ; it may be placed in the conduit or on the orifice of the valve, valve stem or actuator and in some instances it may also cover the surroundings thereof. The valve, valve stem and actuator may have any size or shape ; it is only necessary to secure that the amount of sealing material employed is sufficient to completely block the terminal orifice of the aerosol dispenser.

35 The sealing material may be introduced at the desired place of the exit conduit (valve-, valve stem-, or actuator orifice or conduit) by known techniques, e.g. manually, by injection, hot molding, dip-coating, coating or other techniques well known in the art.

These and other features and objects of the present invention will become more apparent from the following description taken in conjunction with the accompanying drawings wherein :

40 Fig. 1 is a schematic drawing of sectional view, illustrating one preferred embodiment of this invention, i.e. a total release overcap wherein the sealing material is placed either "on" or "in" the orifice of the overcap (serving as actuator).

45 Fig. 2 is a schematic drawing of sectional view, illustrating an other preferred embodiment of this invention, i.e. an aerosol valve wherein the sealing material is placed either "on" or "in" the orifice of the valve stem. The actuator is not shown, nor are details drawn from the valve. For more details see for example, Handbook of Aerosol Technology, supra.

50 Fig. 3 is a schematic drawing of sectional view, illustrating another preferred embodiment of this invention, i.e. a button-lock actuator wherein the sealing material is placed either "on" or "in" the orifice of the button-lock actuator.

Referring to Fig. 1, the total release overcap is shown with the sealing material placed either "on" 1 or "in" 2 the orifice 3 of the overcap. Fig. 1A is a plan view of the top of the overcap ; Fig. 1B is a side sectional view of said overcap and Fig. 1C is enlarged view of the middle section of the overcap in a position in which it is used for delayed actuation.

55 In operation, the cap which normally serves as a cover for shipping or storing is inverted to actuate the valve of the can. Thereupon the content of the container interacts with the sealing material (by pressure or solvent effects) and begins to actuate such material until it is displaced. Only then the content of the can is released.

Referring now to Fig. 2, the aerosol valve (Handbook of Aerosol Technology, supra at 85) is shown with the material susceptible to the container's content placed either "on" 4 or "in" 5 the valve stem 6 of the aerosol valve assembly. Fig. 2 is a side sectional view of the aerosol valve assembly showing the stem 6, body of the valve 7, diptube 8 and mounting cup 9.

In operation, whenever the actuator (not shown) attached to the valve stem of the container is engaged, the content of the container interacts with the sealing material placed "in" or "on" the valve stem and begins to actuate such material until it is displaced. After removal of the sealing material the content of the can is released.

Referring now to Fig. 3, the button-lock actuator (Handbook of Aerosol Technology, supra at 111) is shown with the sealing material placed either "on" 10 or "in" 11 the orifice 12 of the actuator.

Fig. 3A is a side sectional view of the actuator and Fig. 3B is an enlarged view of the middle section thereof.

In operation, whenever the actuator attached to the valve stem of the container is engaged, the content of the container interacts with the sealing material placed "in" or "on" the orifice of the actuator and begins to affect such material until it is displaced. The content of the can is only released with time delay, i.e. after expiration of the time required for the removal of the sealing material.

The sealing materials are either placed between the valve and the actuator, or built "in" or "on" the actuator or the valve stem of the total-release container. The delayed actuation is triggered by engaging the actuator (i.e. by opening the valve). The container's content begins then to affect the sealing material, which results finally - after a predeterminable period of time - in the removal of such sealing material and allows thereupon the delayed total-release of the contents of the aerosol dispenser. The delay in time depends on the type and amount of sealing material used and on the contents of the container.

The sealing material can be placed either "in" or "on" the valve, preferably valve stem, into the stem orifice(s), if there are any, in the wall of the stem or in the stem seat (spring cap). The details describing the different types of valves, valve stems and various other parts thereof can be found in Handbook of Aerosol Technology, supra, pp. 85-111.

Similarly, the sealing material can be placed "in" or "on" the actuator or overcap of any size or shape. Actuators and their functions are generally described in Handbook of Aerosol Technology, supra, pp. 111-114.

The orifice can be of various shapes and sizes. Such orifices are made in conventional manner.

The current invention is useful for any kind of administration and total-release of harmful, hazardous, noxious or unpleasant contents of various containers and similar devices to the surrounding environment, which administration could be otherwise harmful, un-pleasant, impractical or risky to the operator of such device. In such situations, time is needed to get away from the container before it releases its contents.

The device of this application allows the application of various pesticides, fumigating agents, even hazardous materials which normally cannot be applied without safety hazards, without complicated health protections such as masks, respirators, special clothes, etc. Sometimes, such materials cannot be applied at all without substantial health risk to the operator.

Utilizing this invention, the operator of a device containing any kind of harmful substance installs the device in the appropriate place, engages the actuator, valve or other triggering unit and leaves. The sealing material now comes in contact with the contents of the container which slowly acts onto the sealing material which is susceptible to that content. In due time (controlled by choice of materials, thickness, formulation, dimensions and location), such material fatigues and is displaced thus opening the terminal orifice in the system and allows the content of the container to be released to the environment.

The device of this invention can be similarly used to activate fire extinguishers in a case of unattended fire, tranquilize wild animals or disturbed or violent people without endangering personnel, administer various detoxicants, disinfectants, anesthetic agents and other agents of a similar type. The uses such as a landing area marker or a rescue markersite is also possible.

The following examples are intended to illustrate the current invention. They are not to be interpreted as limiting the current invention to the material appearing in the examples.

Example 1 : Delayed Actuation-Unformulated Materials

This example illustrates a delayed actuation using containers with various contents and unformulated sealing materials susceptible to actuation.

I. Adhesive Tapes

An adhesive disk of the materials listed below was placed over/on an exit orifice of total release actuator of pressurized insecticide/ solvent containing room fogger. Then the actuator was engaged and the time delay measured in which the actual release from the container occurred.

| <u>Material</u> | <u>Delay Time</u> |
|-------------------------------------|-------------------|
| Scotch [®] 810 | 3.0 sec |
| Scotch [®] CW71544AAV 4152 | 1.5 sec |
| R-Tape [®] (Clean) | 2.5 sec |
| Silver Cloth [®] Tape | 3.0 sec |

Depending on the tape material, the solvent and/or pressure from the fogger was able to disintegrate the tape within 1.5 to 3 seconds.

II. Greases

Grease was placed in the valve stem of the aerosol container, the valve was opened and the time delay of the actuation was measured.

| <u>Material</u> | <u>Delay Time</u> |
|-----------------|-------------------|
| Silicone Grease | 1 sec |

The pressure of the aerosol was able to push through the orifice the grease in approximately 1 second. By changing the softness of the grease employed, it is possible to regulate the time delay on release.

III. Parafilm[®]

A piece of Parafilm[®] of various thicknesses was placed at the interface of a valve stem and actuator of the generally available insecticidal total-release bomb fogger and the delayed actuation was measured.

| <u>Material</u> | <u>Delay Time</u> |
|-----------------------|-------------------|
| Parafilm [®] | - |
| Thickness .005" | 8.0 sec |
| Thickness .010" | 25-80 sec |
| Thickness .015" | 5 min |

By changing the thickness of the material, it is possible to regulate the time delay on release.

IV. Polyethylene

High density polyethylene film (3/1000 inches) was installed at the interface of the valve and actuator of room fogger and the time delay measured.

MaterialDelay Time

Polyethylene

No actuation in 60 min

Polyethylene material did not rupture, dissolve or disintegrate for at least 60 minutes of the experiment.

V. Other Materials

Using the procedure of sections I-IV of this example, the time delay of other types of containers and other materials are determined.

Example 2 : Delayed Actuation-Formulated Materials

This example illustrates a delayed actuation using various containers, actuating agents and formulated materials susceptible to actuation.

i. Polymer Resins/Plasticizers

Combinations of polymer resins/plasticizers (Formulation) have been prepared in the formulations listed below :

| Formulation | 1 | 2 | 3 | 4 |
|-------------------------------|--------------|--------------|--------------|--------------|
| <u>Raw Materials</u> | <u>Batch</u> | <u>Batch</u> | <u>Batch</u> | <u>Batch</u> |
| Piccopale [®] 100-SF | 10 | 8.0 | 7.6 | 8.3 |
| D.O.A. | - | 2.0 | 3.4 | 1.7 |
| FD&C Blue | - | 0.1 | - | - |
| FD&C Red | - | - | 0.1 | - |
| FD&C Black | - | - | - | 0.1 |
| | 10 | 10.1 | 11.1 | 10.1 |

D.O.A. means dioctyl adipate ;

FD&C means Food, Drugs & Cosmetics.

All formulations prepared according to the above schedule were heated until molten, then placed on and over the orifice at the underside of the fogger actuators (20 of each formula). The formulations were allowed to cool to an ambient temperature. Then the actuator was engaged and time delay measured in which the actual release from the container occurred.

Fogger actuators used in this example were a standard button-lock type (total release # 01-3686) obtained from Precision Valve Corp., Yonkers, N.Y., an overcap (total release overcap # C82-0118-00) obtained from Seaquist, Division of Pittway Corp., Cary, N.C., and a fogger actuator cap from Seaquist. (# means catalogue number.)

| <u>Formulation</u> | <u>Delay Times</u> | <u>No. of Trials</u> |
|--------------------|-----------------------------|----------------------|
| 1 | more than 6 hours | 5 |
| 2 | from 1:44 min to 2:04 min | 5 |
| 3 | from 25 sec to 34 sec | 5 |
| 4 | from 13:27 min to 15:12 min | 5 |

The above formulations produced a small resin worm which passed through the fogger actuator until all of the resin/plasticizer formulation which blocked the orifice was expelled. Due to solvent and/or pressure effects on the resin/plasticizer formulation, the formulation ruptured and allowed for total-release of the contents of the fogger.

II. Polymer Resins/Plasticizers

a. In these formulations the ratio of plasticizer v. polymer resin were as follows :

| <u>Formulations</u> | <u>5</u> | <u>6</u> |
|------------------------------|----------------|----------------|
| <u>Raw Materials</u> | <u>Batch</u> | <u>Batch</u> |
| | <u>(wt/%)</u> | <u>(wt/%)</u> |
| Piccopale [®] 100SF | 80.20% | 81.20% |
| D.O.A. | 18.80% | 17.80% |
| Fluorescent Orange | 1.00% | - |
| Fluorescent Yellow | - | 1.00% |
| | <u>100.00%</u> | <u>100.00%</u> |

These formulations were inserted in an amount from 0.010-0.002 g, into the bottom side orifice of a button-lock actuator and in Seaquist cap actuators. The time delay of total-release was measured after the actuator was engaged.

Button-Lock Actuator

| <u>Formulation</u> | <u>Delay Time</u> | <u>No. of Trials</u> |
|--------------------|---------------------------|----------------------|
| 5 | from 1:48 min to 2:30 min | 6 |
| 6 | from 12 min to 16:04 min | 6 |

Seaquist Cap Actuator

| <u>Formulation</u> | <u>Delay Time</u> | <u>No. of Trials</u> |
|--------------------|-----------------------------|----------------------|
| 5 | from 1:44 min to 2:11 | 6 |
| 6 | from 13:41 min to 16:10 min | 6 |

b. Other formulations in amount 0.001-0.100 g are inserted into an orifice of any actuator depending on formula ratio.

III. Other Formulations

Following the above procedure, the other combination formulations are prepared and tested for time delayed actuation of total-release containers of various types.

Example 3 : Formulations Process

Formulations useful for delayed actuation were prepared by mixing the D.O.A. with fluorescent dye, for example fluorescent orange or fluorescent yellow or with blue, red, black or other dye pigments. The mixture was heated up to 100°C. Then, the polymer resin was added and the whole mixture was heated up to 100°C again until it was molten and homogenous. In the molten stage it was applied to the actuator, valve stem, valve or orifice therein.

Claims

1. A continuous aerosol dispenser comprising a container, an exit conduit concluding at a terminal orifice, a valve stem, a valve, a continuous valve actuator for discharging the container contents through the terminal orifice, characterized in that a sealing material is placed between the valve and the actuator or built in or on the actuator or on the valve stem and in that the valve separates the container contents from the sealing material, whereby upon mechanical actuation of the valve, the sealing material is susceptible to removal after a predeterminable period of time through the pressure executed by the container contents, thereby delaying the release of the container contents for such predeterminable period of time.

2. The device of Claim 1 wherein the sealing material is selected from the group consisting of polyethylene, laboratory foil and a formulated combination of resin and plasticizer.

3. The device of Claim 2, wherein the laboratory foil is low density polyethylene foil formulated with paraffin wax.

4. The device of Claim 2, wherein the sealing material is a formulated combination of polymer resin and plasticizer, such formulation comprising the resin and plasticizer in a weight ratio of from 50 : 50 to 90 : 10.

5. The device of Claim 4, wherein the sealing material is a formulation comprising from 79 to 82% by weight of resin, from 17% to 20% by weight of plasticizer, the balance being formulating agents.

6. The device of Claims 4 or 5, wherein the plasticizer is a phthalate or adipate.

7. The device of any one of Claims 1 to 6, wherein the sealing material is at the interface of the valve and valve actuator.

8. The device of any one of Claims 1 to 6, wherein the sealing material is in removable association with the valve stem.

9. The device of any one of Claims 1 to 6, wherein the sealing material is in removable association with the valve actuator.

10. The device of Claim 9, wherein the actuator is in the form of an overcap.

11. A method for delaying the release of the contents of a continuous aerosol dispenser, said dispenser comprising a container, an exit conduit concluding at a terminal orifice, a valve stem, a valve, and a continuous valve actuator for discharging the container contents through the terminal orifice, said method comprising placing a sealing material susceptible to removal after a predeterminable period of time through the pressure executed by the container contents between the valve and the actuator, or building said sealing material in or on the actuator or on the valve stem so that the valve separates the container contents from the sealing material, whereby upon mechanical actuation of the valve, the sealing material is removed after a predeterminable period of time, thereby delaying the release of the container contents.

Ansprüche

1. Kontinuierlicher Aerosolzerstäuber, umfassend einen Behälter, eine Auslaßleitung, die mit einem Endmundstück, einem Ventilschaft, einem Ventil, einem kontinuierlichen Ventilsprühkopf zum Austragen des Behälterinhalts durch das Endmundstück endet, dadurch gekennzeichnet, daß ein Dichtungsmaterial zwischen dem Ventil und dem Sprühkopf angeordnet ist oder in oder auf dem Sprühkopf oder auf dem Ven-

tilschafft gebildet ist, und daß das Ventil den Behälterinhalt von dem Dichtungsmaterial trennt, wobei bei mechanischer Betätigung des Ventils das Dichtungsmaterial nach einem vorbestimmbaren Zeitraum durch den Druck, der durch den Behälterinhalt ausgeübt wird, entfernt werden kann, wodurch die Freisetzung des Behälterinhalts über einen solchen vorbestimmbaren Zeitraum verzögert wird.

5 2. Vorrichtung nach Anspruch 1, wobei das Dichtungsmaterial ausgewählt ist aus der Gruppe bestehend aus Polyethylen, Laborfolie und einer eingestellten Zusammensetzung von Harz und Weichmacher.

3. Vorrichtung nach Anspruch 2, wobei die Laborfolie eine Polyethylenfolie niedriger Dichte ist, die mit Paraffinwache formuliert ist.

10 4. Vorrichtung nach Anspruch 2, wobei das Dichtungsmaterial eine eingestellte Zusammensetzung von Polymerharz und Weichmacher ist, so daß die Formulierung das Harz und den Weichmacher in einem Gewichtsverhältnis von 50 : 50 bis 90 : 10 umfaßt.

5. Vorrichtung nach Anspruch 4, wobei das Dichtungsmaterial eine Formulierung ist, die 79 bis 82 Gew.-% Harz, 17 bis 20 Gew.-% Weichmacher umfaßt, wobei der Gewichtsausgleich Formulierungsmittel sind.

6. Vorrichtung nach Anspruch 4 oder 5, worin der Weichmacher ein Phthalat oder Adipat ist.

15 7. Vorrichtung nach einem der Ansprüche 1 bis 6, worin das Dichtungsmaterial sich an der Grenzfläche zwischen Ventil und Ventilsprühkopf befindet.

8. Vorrichtung nach einem der Ansprüche 1 bis 6, wobei das Dichtungsmaterial mit dem Ventilschaft entfernbar verbunden ist.

20 9. Vorrichtung nach einem der Ansprüche 1 bis 6, wobei das Dichtungsmaterial mit dem Ventilsprühkopf entfernbar verbunden ist.

10. Vorrichtung nach Anspruch 9, wobei der Sprühkopf als Abschlußkappe ausgebildet ist.

11. Verfahren zum Verzögern der Freisetzung des Inhalts eines kontinuierlichen Aerosolzerstäubers, wobei der Zerstäuber einen Behälter, eine Auslaßleitung, die mit einem Endmundstück, einem Ventilschaft, einem Ventil und einem kontinuierlichen Ventilsprühkopf zum Austragen des Behälterinhalts durch das Endmundstück endet, umfaßt, wobei das Verfahren daraus besteht, daß man ein Dichtungsmaterial, das nach einem vorbestimmbaren Zeitraum durch den Druck, den der Behälterinhalt ausübt, entfernt werden kann, zwischen Ventil und Sprühkopf anordnet oder das Dichtungsmaterial in oder auf dem Sprühkopf oder auf dem Ventilschaft ausbildet, so, daß das Ventil den Behälterinhalt von dem Dichtungsmaterial trennt, wodurch bei mechanischer Betätigung des Ventils das Dichtungsmaterial nach einem vorbestimmbaren Zeitraum entfernt wird und dadurch die Freisetzung des Behälterinhalts verzögert wird.

Revendications

35 1. Diffuseur en continu d'aérosol comprenant un récipient, un conduit de sortie se terminant par un orifice terminal, une tubulure de valve, une valve, un bouton d'actionnement de valve en continu pour décharger le contenu du récipient à travers l'orifice terminal, caractérisé en ce qu'une matière d'étanchéité est placée entre la valve et le bouton d'actionnement ou intégrée dans ou sur le bouton d'actionnement ou sur la tubulure de valve et en ce que la valve sépare le contenu du récipient de la matière d'étanchéité, la matière d'étanchéité étant susceptible, par actionnement mécanique de la valve, d'être expulsée après une période de temps déterminable au préalable sous l'action de la pression exercée par le contenu du récipient, diffé-

40 rant ainsi la libération du contenu du récipient pendant cette période de temps déterminable au préalable.

2. Dispositif selon la revendication 1, dans lequel la matière d'étanchéité est choisie dans le groupe constitué par le polyéthylène, un film de laboratoire et une combinaison formulée de résine et de plastifiant.

45 3. Dispositif selon la revendication 2, dans lequel le film de laboratoire est un film de polyéthylène basse densité formulé avec de la cire de paraffine.

4. Dispositif selon la revendication 2, dans lequel la matière d'étanchéité est une combinaison formulée de résine polymère et de plastifiant, une telle formulation comprenant la résine et le plastifiant dans un rapport pondéral de 50 : 50 à 90 : 10.

50 5. Dispositif selon la revendication 4, dans lequel la matière d'étanchéité est une formulation comprenant de 79 à 82% en poids de résine, de 17% à 20% en poids de plastifiant, le reste étant des agents de formulation.

6. Dispositif selon la revendication 4 ou 5, dans lequel le plastifiant est une phtalate ou adipate.

55 7. Dispositif selon l'une quelconque des revendications 1 à 6, dans lequel la matière d'étanchéité est à l'interface de la valve et du bouton d'actionnement de la valve.

8. Dispositif selon l'une quelconque des revendications 1 à 6, dans lequel la matière d'étanchéité est en association démontable avec la tubulure de valve.

9. Dispositif selon l'une quelconque des revendications 1 à 6, dans lequel la matière d'étanchéité est

en association démontable avec le bouton d'actionnement de la valve.

10. Dispositif selon la revendication 9, dans lequel le bouton d'actionnement est sous forme d'un bouchon recouvrant.

5 11. Procédé pour différer la libération du contenu d'un diffuseur en continu d'aérosol, ledit diffuseur comprenant un récipient, un conduit de sortie se terminant par un orifice terminal, une tubulure de valve, une valve et un bouton d'actionnement de valve en continu pour décharger le contenu du récipient à travers l'orifice terminal, ledit procédé consistant à placer, entre la valve et le bouton d'actionnement, une matière d'étanchéité susceptible d'être expulsée après une période de temps déterminable au préalable sous l'action de la pression exercée par le contenu du récipient ou à intégrer ladite matière d'étanchéité dans
10 ou sur le bouton d'actionnement ou sur la tubulure de valve, de manière que la valve sépare le contenu du récipient de la matière d'étanchéité, la matière d'étanchéité étant expulsée, par actionnement mécanique de la valve, après une période de temps déterminable au préalable, différant ainsi la libération du contenu du récipient.

15

20

25

30

35

40

45

50

55

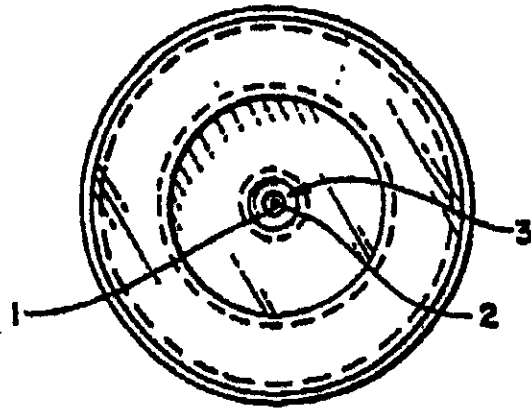

FIG. 1a

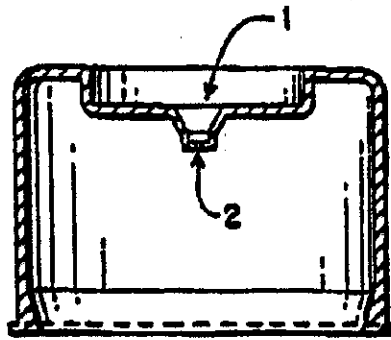

FIG. 1b

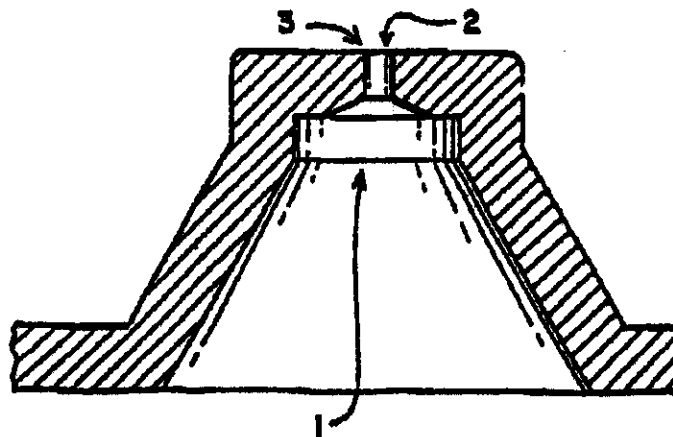

FIG. 1c

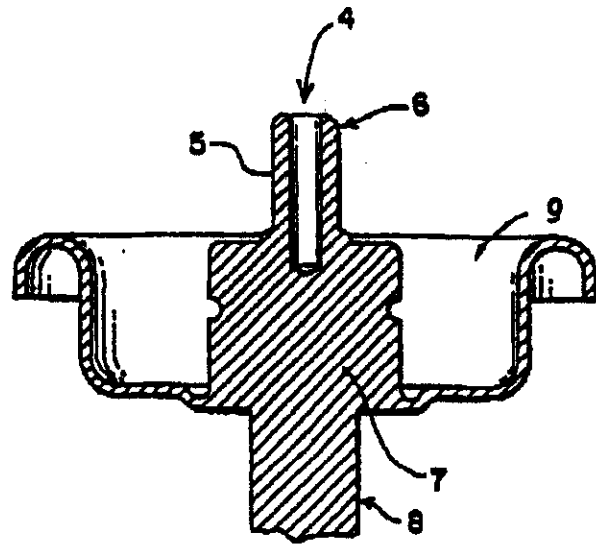

FIG. 2

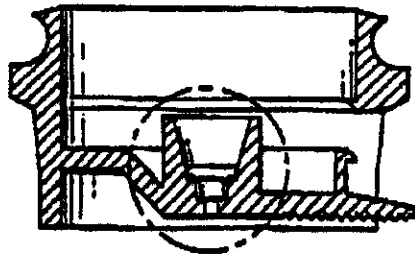

FIG. 3a

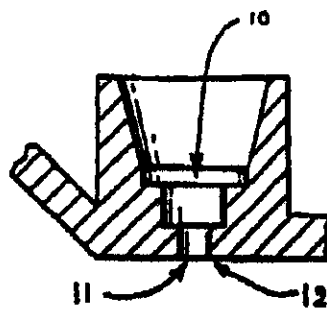

FIG. 3b

REGISTER ENTRY FOR EP0220132

European Application No EP86810452.2 filing date 14.10.1986

Priority claimed:

24.10.1985 in United States of America - doc: 790925

Designated States BE CH DE ES FR GB GR IT LI NL SE AT

Title TIME DELAYED TOTAL-RELEASE AEROSOL DISPENSERS

Applicant/Proprietor

SANDOZ AG, Lichtstrasse 35, CH-4002 Basel, Switzerland

[ADP No. 50573864001]

Inventor

ROBERT C. PEARCE, 3704 Palomino Drive, Arlington Texas 76017, United
States of America

[ADP No. 54774807001]

Classified to

F1R
B65D

Address for Service

B A YORKE & CO, Coomb House, 7 St John's Road, Isleworth, Middlesex, TW7
6NH, United Kingdom

[ADP No. 00001800001]

Publication No EP0220132 dated 29.04.1987

Publication in English

Examination requested 14.10.1986

Patent Granted with effect from 06.03.1991 (Section 25(1)) with title TIME
DELAYED TOTAL-RELEASE AEROSOL DISPENSERS.

26.02.1988 EPO: Search report published on 02.03.1988

Entry Type 25.11 Staff ID.

Auth ID. EPT

04.02.1991 Notification from EPO of change of Applicant/Proprietor details
from

SANDOZ AG, Lichtstrasse 35, CH-4002 Basel, Switzerland

[ADP No. 50573864001]

to

SANDOZ AG, Lichtstrasse 35, CH-4002 Basel, Switzerland

[ADP No. 50573864001]

Entry Type 25.14 Staff ID. RD06 Auth ID. EPT

11.04.1991 B A YORKE & CO, Coomb House, 7 St John's Road, Isleworth,
Middlesex, TW7 6NH, United Kingdom

[ADP No. 00001800001]

registered as address for service

Entry Type 8.11 Staff ID. AW1 Auth ID. AA

**** END OF REGISTER ENTRY ****

OA80-01
EP

OPTICS - PATENTS

13/12/93 11:52:35
PAGE: 1

RENEWAL DETAILS

PUBLICATION NUMBER EP0220132

PROPRIETOR(S)
SANDOZ AG, Lichtstrasse 35, CH-4002 Basel, Switzerland

DATE FILED 14.10.1986

DATE GRANTED 06.03.1991

DATE NEXT RENEWAL DUE 14.10.1994

DATE NOT IN FORCE

DATE OF LAST RENEWAL 23.09.1993

YEAR OF LAST RENEWAL 08

STATUS PATENT IN FORCE