

(No Model.)

F. JOHNSON.  
CLAMPING MECHANISM.

No. 509,129.

Patented Nov. 21, 1893.

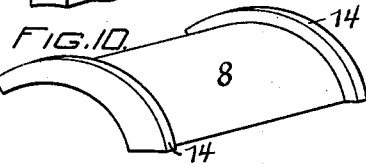
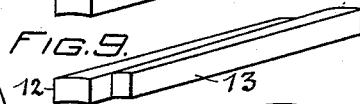
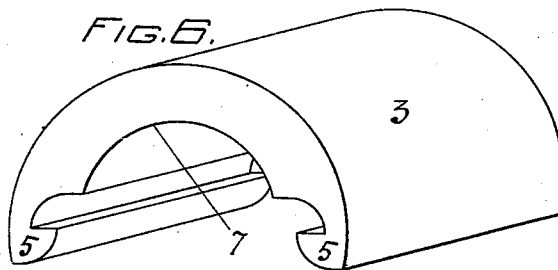
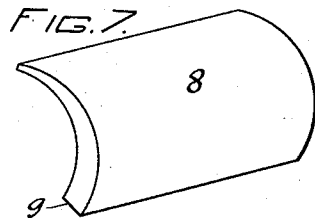
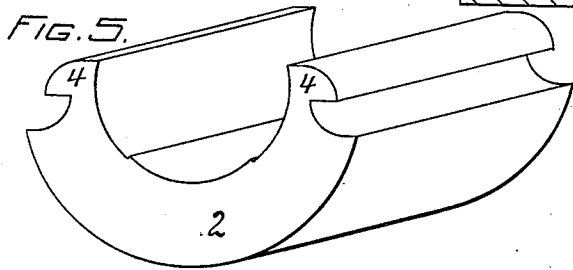
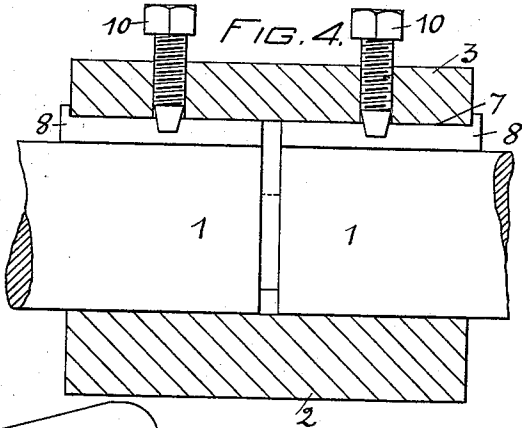
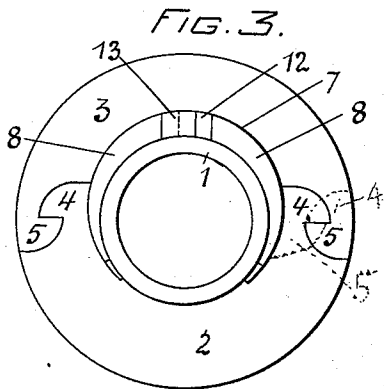
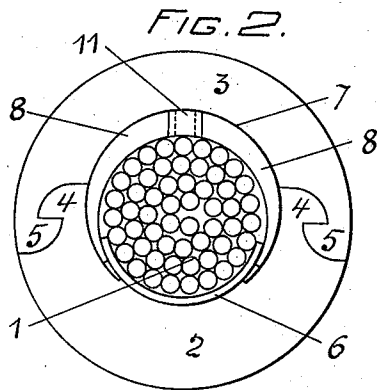
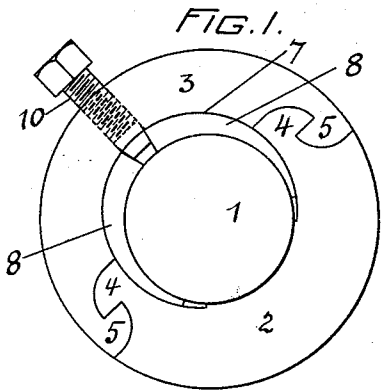

WITNESSES:  
*John W. Achard*  
*J. C. Prindle*

INVENTOR:  
*Ferdinand Johnson*  
BY *Sheldon Meigs*  
ATT'Y.

# UNITED STATES PATENT OFFICE.

FERDINAND JOHNSON, OF NEW LONDON, PENNSYLVANIA.

## CLAMPING MECHANISM.

**SPECIFICATION** forming part of Letters Patent No. 509,129, dated November 21, 1893.

Application filed March 18, 1893. Serial No. 466,624. (No model.)

*To all whom it may concern:*

Be it known that I, FERDINAND JOHNSON, a citizen of the United States, residing in New London township, in the county of Chester and State of Pennsylvania, have invented certain new and useful Improvements in Clamping Mechanisms; and I do hereby declare the following to be a sufficiently full, clear, and exact description thereof as to enable others skilled in the art to make and use the said invention.

This invention relates to clamps for fastening upon objects having parallel sides or nearly parallel sides such as bars, shafts, tubes, ropes and cables and has for its objects to receive motion therefrom, impart motion thereto, or to support, or procure support from such objects.

To secure these desiderata this invention consists of a clamp formed of two interlocking parts, which, when assembled, embrace the object to which they are applied and two or more eccentric wedges, and means of forcing said wedges into converging spaces, in a direction transverse to the length of the object to which the clamp is applied. Such clamps are useful in making connections or attachments to shafts, ropes and cables, and pump rods for the transmission of power, and in constructing scaffolds and in permanent structures of metal work.

The construction and operation of this invention are hereinafter fully described and illustrated in the accompanying drawings.

Referring to the drawings, Figure 1 shows an end view of a clamp embodying this invention, as applied to a cylindrical shaft; Fig. 2 a like view, as applied to a wire cable; Fig. 3 a like view, as applied to a tube. Fig. 4 shows a lengthwise section of a duplex form of the invention, applicable to the union of revolving shafts as a coupling for power transmission. Figs. 5, 6, 7, and 8 are detached views of parts of the invention. Figs. 9 and 10 are modified forms of the part of the device for operating and securing the eccentric wedges.

1 represents the bar or other object to which the clamp is applied.

2 and 3 are grooved shells having interlocking hooks 4 and 5 by which they engage each

other. The groove in the clamp 2 is of such size and form as to fit on the object 1, or if not of such size, a bushing or liner may be applied to adapt it to fit as indicated at 6 in Fig. 2. The groove 7, in the clamp 3, is made eccentric to that in the clamp 2; in the eccentric groove there are introduced eccentric segmental wedges 8, the inner sides of which are an approximate fit to the body 1, and the outer sides to the groove 7. When the eccentric segmental wedges are introduced their thicker edges 9 should be close to each other. The wedges 8 are tightened by forcing them apart, into the converging part of the crescent shaped space, in the grooves between the body 1 and clamp 3. The forcing of the wedges 8 apart to tighten the clamp is accomplished by means of a tapering pointed screw 10, screwed through the clamp 3 as shown in Fig. 1, or by means of a tapering key 11, as shown in Fig. 2; the edges of the key 11, and the thicker edges of the wedges 8, opposed to the key 11 being helical in form.

As shown in Fig. 3 two keys 12 and 13 are used, the parallel sides of which press against the thick edges of the wedges 8, and the helical sides of the keys 12 and 13 fit against each other; the effect of forcing the wedges 8 into the converging spaces between the object 1 and the clamps 3, is the same although the substitution of screws and wedges changes the form of this part.

The form in Fig. 4, in lengthwise section, is simply two pairs of wedges 8, in the opposite ends of clamps 2 and 3 so that each pair of wedges can be tightened independently of the other, to adapt them to shafts of differing diametral dimensions.

The clamps may have formed on them projections, or other parts adapted to mechanical use, as for instance brackets to support scaffolds or frame work, pulleys or gear wheels to transmit rotative motion and power, or they may be fitted to engage sprocket wheels, or to propel loads as in elevators, or cable transmission of power, or as collars to restrict endwise motion of shafts or arbors in machinery. The clamping action is the same in all cases.

The wedges 8, 8, may have lips 14 formed on the ends as shown in Fig. 10, which pre-

vent any endwise motion after they are tightened and the keys 11, 12, and 13 may be of ductile metal, and bent or left as shown at 15 in Fig. 8 and expanded after tightening to prevent working loose.

5 Having described my invention, what I claim is—

10 A clamp formed of two separable parts having lengthwise interlocking grooves and hooked tongues adapted when assembled to inclose an object and leave a transversely con-

verging space between such object and the interior of the clamp, in combination with wedges adapted to fit and be guided in such space, and means for forcing said wedges apart and thereby compressing and clamping the inclosed object, substantially as set forth.

FERDINAND JOHNSON.

Witnesses:

A. McCORMICK,  
ED. E. RUTTE.