

No. 882,811.

PATENTED MAR. 24, 1908.

A. R. BAILEY.  
WATER STILL.

APPLICATION FILED SEPT. 17, 1902.

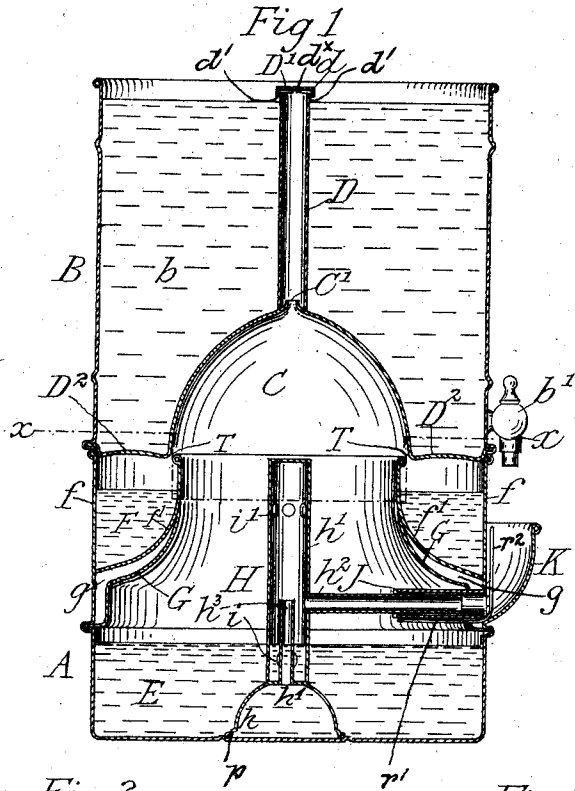

Fig. 2

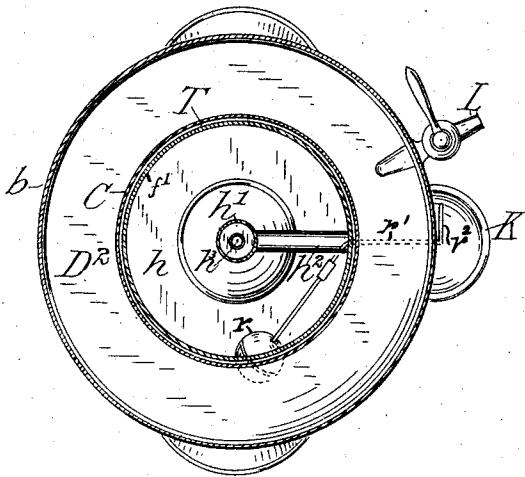
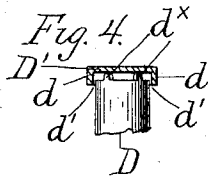
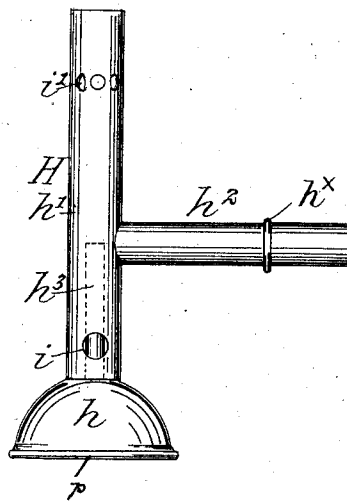

Fig. 3



Witnesses:  
Edward J. Murphy.  
Samuel W. Balch

Inventor:  
Arthur R. Bailey  
by G. L. Wheelock  
Attorney.

# UNITED STATES PATENT OFFICE.

ARTHUR R. BAILEY, OF NEW YORK, N. Y., ASSIGNOR TO THE SANITARY WATER-STILL COMPANY, OF BROOKLYN, NEW YORK.

## WATER-STILL.

No. 882,811.

Specification of Letters Patent.

Patented March 24, 1908.

Application filed September 17, 1902. Serial No. 123,724.

*To all whom it may concern:*

Be it known that I, ARTHUR R. BAILEY, a citizen of the United States of America, and a resident of New York, borough of Brooklyn, and State of New York, have invented certain new and useful Improvements in Water-Stills, of which the following is a specification.

My invention relates to improvements on that class of water still for which United States Letters Patent No. 650,501, dated May 29, 1900, were granted to me, and its general objects are to provide an extremely simple, effective and practicable water still for household and other purposes. Its specific objects are, first, to provide a nearly closed pure water reservoir, in which the water is received and stored as fast as it is condensed, constructed to obviate the bitter, unpleasant, insipid taste which is often present in distilled water; second, to provide improved means for forcing aeration by causing a current of sterilized air to pass through the still which carries with it those volatile impurities which always exist in water having vegetable or organic matter therein, and which are liberated by the boiling process; and, third, to provide improved means for shielding or protecting the upper end of the ventilating flue, through which the volatile impurities escape so as to prevent a careless user from pouring water into the ventilating flue while filling the water supply reservoir.

My invention consists in certain features of construction and combination of parts as hereinafter described and claimed.

In order that my invention may be fully understood, I will proceed to describe it with reference to the accompanying drawings, in which:

Figure 1 is a vertical central section of my improved water still. Fig. 2 is a transverse section thereof taken on the line  $x-x$ , Fig. 1. Fig. 3 is a detail side elevation of the aerating device. Fig. 4 is a detail view of the upper end of the ventilating tube and cap or hood.

As shown in my former patent hereinbefore referred to, the water-still comprises a lower part A and an upper part B. The upper part B is of any suitable shape and provides a water supply reservoir  $b$  having a discharge faucet  $b'$ . The lower end of the upper part B is suitably formed so as to remov-

ably rest upon the upper end or rim of the lower part A and is provided over the lower part A with a condensing dome C, the apex of which is connected by means of a small jet orifice  $C'$  with a vertical cylindrical ventilating flue D surrounding the jet orifice  $C'$ , supported upon the dome C and having projections  $d^x$  at its upper end where it is surmounted and partly closed by a shielding or protecting cap or hood  $D'$  having a depending flange or rim  $d$  and supported by suitable means such as the projections  $d^x$  over the upper end of the ventilating flue D so as to leave a space, or openings  $d'$  therearound for the escape of the volatile impurities from the condensing dome C, while at the same time, the cap, or hood,  $D'$  precludes the accidental pouring of water into the ventilating flue D instead of into the water supply reservoir  $b$ .

The lower part A of the still has to withstand the action of direct heat, and is therefore made, preferably, of copper, while the other parts of the still may be made of any suitable material. The base of the lower part A provides a retort or boiler E. Above this retort E, the lower part A is provided, on the inner circumference of its cylindrical wall, with a trough-shaped distilled or pure water reservoir F, which is formed by the upper part  $f$  of the said wall and by an approximately frusto-conical inner wall  $f'$ . The upper end of the inner wall  $f'$  forms a mouth, or passage, connecting the retort E with the condensing dome C and is located concentric with the axis of the same. The greatest diameter of the condensing dome C, which is at its lower end, is only slightly greater than the upper end of the inner wall  $f'$  which it surrounds, being separated therefrom by a narrow or contracted annular passage, or space, T through which the water condensed from the steam trickles into the pure water reservoir F. The lower end of the condensing dome C is connected with the wall of the upper part B by an annular bottom plate  $D^2$ , which, with the condensing dome C, forms the bottom of the water supply reservoir  $b$ . The annular bottom plate  $D^2$ , being only slightly less in width than the width of the pure water reservoir, provides a top, or cover, forming an almost complete closure to the latter, so that the pure water reservoir F is closed, with the

exception of the contracted annular passage T. In a still constructed on a scale about three times that of Fig. 1 the said annular passage T is best made of a width of approximately one-eighth of an inch.

The width of the annular bottom plate D<sup>2</sup> and hence the width of the contracted passage T referred to, must be such, that the entrance of the impure vapors, or undensified steam, into the pure water reservoir F through the contracted passage T is precluded by the upward draft through the condensing dome C, as the passing of any vapors, or steam, into the pure water reservoir F impairs the quality of the distilled water, as well as its purity, and renders it objectionable to the taste of the user.

Located over the retort E under the inner wall *f'* of the pure water reservoir F is an approximately frusto-conical protecting wall G for the inner wall *f'* of the pure water reservoir F, separated from the inner wall *f'* so as to provide a dead air space *g* between the protecting wall C and the inner wall *f'* and thus prevent the lower part of the latter from being exposed to the direct heat of the steam in the retort E, and diminishing to a large extent the conduction of heat to the pure water reservoir F and the adjacent part of the wall of the lower part A of the still, thereby reducing the temperature of the distilled water as compared with that of the water in the retort E. It will be understood that if this protecting wall G was omitted, the temperature of the distilled water would more closely approximate to that of the water in the retort E. Also, the presence of the wall G and the dead air space around it prevents such a lowering of the temperature of the exposed surface of said wall by the lower temperature of the water in the distilled water reservoir as to prevent a condensation of steam on said surface.

Another and most important feature of the present invention will now be described. This consists of the means for aerating and eliminating volatile impurities in the water so that a palatable and thoroughly pure water can be obtained.

H is an aerating device of fountain form, seated loosely upon the bottom of the retort E, within an annular bead *p*. It is constructed with a dome-shaped hollow base, or inverted cup *h*, an aerating flue *h'* having a closed bottom and top, and which extends upwardly from the top of the hollow base *h*, a branch or lateral inlet air-tube *h<sup>2</sup>* having an annular bead *h<sup>x</sup>* and extending outwardly from one side of the aerating flue *h'*, and an ejecting tube *h<sup>3</sup>* located within the aerating tube *h'*, connected with a central orifice *h<sup>4</sup>* in the top of the hollow base *h*. The lower part of the aerating flue *h'* is provided at a distance above the hollow base *h*, with a feed

orifice *i* leading into the retort E and at its upper end, below its closed top, with outlet ports *i'*. The branch tube *h<sup>2</sup>* is removably inserted up to its annular bead *h<sup>x</sup>* into a sleeve, or tube, J, which extends inwardly from the wall of the lower part A of the still, preferably through the protecting wall G.

K is a feed cup, with which the sleeve communicates, located on the outside of the lower part A with its open upper end located beneath the discharge faucet *b'* of the water supply reservoir B.

As shown in my patent hereinbefore referred to, I provide a ball-float *r*, which is hung upon an oscillating wire shaft *r'*, journaled beneath the sleeve J, at the base of and within the feed cup K. The wire carries an indicator arm *r<sup>2</sup>* adapted to oscillate within the feed-cup K to show the level, or height, of the water in the retort E.

L is the discharge faucet of the distilled water reservoir F.

The operation of my improved water still is as follows: The water to be distilled is poured into the water supply reservoir *b* until it reaches the desired height therein without overflowing the ventilating flue D, the cap D' of the ventilating flue D precluding any water being poured directly down the same into the retort E. The retort E is filled to the desired height, preferably discharging from the faucet *b'* of the reservoir *b* a suitable quantity of water into the feed-cup K, which enters the retort E through the sleeve J, the branch air tube *h<sup>2</sup>*, aerating flue *h'*, and feed orifice *i*. The still having been placed over a suitable source of heat, the operation of distilling the water in the retort E commences. The heat brings the water to boiling point, produces steam and releases the volatile impurities from the water in the form of vapor, the steam and vapor ascending into the condensing dome C. Within the condensing dome C, the steam condenses upon the exposed surface thereof and the water trickles down the wall thereof through the almost closed contracted annular passage T into the distilled or pure water reservoir F, the annular passage being of such a narrow width as to preclude the entrance of undensified steam, owing, of course, to the natural tendency of the steam to rise and find an exit through the jet orifice C' of the condensing dome C, but as this jet orifice C' is so small and the ventilating flue D is cooled by the water in the reservoir *b* and thereby provides a steam condensing surface, the emitting of the steam from the ventilating flue D is precluded almost entirely while there is no obstacle to the free outlet of the impure vapors from the ventilating flue D. The heating of the retort E is maintained until a sufficient quantity of water has been converted into steam and distilled to fill the pure

water reservoir F, (which is known by the position of the indicator-arm  $r^2$ ) within the feed-cup K. Obviously an overflow may be provided for this purpose. The aeration of the boiling water is accomplished by the aerating device H in the following manner. The free entrance of water from the retort E into the hollow base  $h$  of the aerator H, is somewhat precluded owing to the seating of the hollow base  $h$  within the annular bead  $p$  upon the bottom of the retort E, consequently steam is quickly generated in the hollow base  $h$ , tending to exhaust the water therein and thus draw in a further supply of water under the hollow base  $h$ . The drawing in of the water is assisted by gravity, the steam produced tending to emit the water in the hollow base  $h$  in the form of a steam and water jet which squirts from the ejecting tube  $h^3$ , up into the upper part of the aerating flue  $h'$ , the water flowing back and finding an outlet through the feed orifice  $i$ , while the steam and the freely entering air within the aerating flue  $h'$  pass out through the outlet ports  $i'$  of the latter. The jet of steam and water forces the air out of the upper end of the aerating flue  $h'$ , into the condensing dome C, and through the ventilating tube D, and simultaneously draws in an additional supply of air through the feed-cup K, sleeve J and branch tube  $h^3$ . The object of this forced draft is to produce a continuous current of air through the still, carrying off the impurities from the vapor and supplying it with sterilized air. It will be observed that by the described aeration, the air is drawn into the still by the mechanical action of the boiling water, is washed and sterilized by a spray of superheated steam and water, and is then, by this mechanical action, forced upward into the condensing dome C, where it is required for use, being, during this process, separated from dust and other particles, which are precipitated into the retort.

Among the advantages of my improved water still may be enumerated the following: That the operation of the still is so simple, a child can place the still on a stove or range and fill the reservoir  $b$  and the retort E from the reservoir and let the still do the rest, its working being entirely automatic, except the drawing off of the distilled water every hour or two, and adding a fresh supply to the reservoir  $b$  and retort E when required; that a thorough cleansing and sterilizing of the air is accomplished even when the still is being operated over a slow fire; that forced aeration, which drives off the volatile impurities, is attained, thereby preventing their re-absorption by the condensed steam, and that the entire aerating device H may be quickly removed for the purpose of cleaning it, by simply first removing the upper

part B and then disconnecting the branch tube  $h^2$  from the sleeve J projecting inwardly from the feed-cup K, as the aerating device merely rests upon the bottom of the retort E within the annular bead  $p$  in line with the axis of the still. A further and an important feature in the present invention is that the empyreumatic gases are driven off immediately, so that they are not re-absorbed by the water to render it bitter, unpleasant or insipid to the taste of the user, all this being accomplished by driving or forcing these gases through the ventilating flue D by the medium of the aerating tube  $h$ .

It is evident that some features of the invention may be used without others and the parts shown may be used in varying forms, and I therefore do not limit myself to the exact construction shown.

Having thus described my invention; the following is what I claim as new therein and desire to secure by Letters Patent:

1. A water-still comprising a lower part having a retort, and a distilled water reservoir thereover, formed with an inner wall providing a mouth leading upwardly from the retort, and an upper part having a water supply reservoir, and a condensing dome, whose lower end surrounds the upper end of the mouth, and from which the water trickles into the said reservoir, the said dome having a jet orifice in its apex, a vertical ventilating flue surrounding the jet orifice and a cap supported over the upper end of the ventilating flue and having a depending flange surrounding the upper end of the ventilating flue and spaced therefrom to provide outlet openings.

2. A water-still comprising a lower part having a retort, a distilled water reservoir thereover formed with an inner wall providing a mouth leading upwardly from the retort, a feed cup, a horizontal sleeve projecting inwardly from the feed-cup between the retort and the distilled water reservoir, for conducting water and air into the retort of the still, a condensing dome whose lower end surrounds the upper end of the said mouth and means leading from the dome for conducting off the impure gases.

3. A water still having an aerating device comprising a hollow base, having a central orifice, a vertical jet tube connected with the central orifice, a vertical flue having a closed bottom and a closed top and surrounding the jet tube, an inlet-branch tube, an outlet orifice beneath the branch tube, and outlet ports above the branch-tube.

4. A water-still comprising a lower part having a retort, a distilled water reservoir thereover, formed with an inner wall providing a mouth leading upwardly from the retort, a sleeve for conducting water and air into the still, and an aerating device com-

prising a hollow base having a central orifice,  
a vertical jet tube connected with the cen-  
tral orifice, a vertical flue having a closed  
bottom and a closed top and surrounding the  
5 jet tube, an inlet branch tube fitted to the  
sleeve, an outlet orifice beneath the branch-  
tube, and outlet ports above the branch-tube.

Signed at New York, N. Y. this 13th day of  
Sept., 1902.

ARTHUR R. BAILEY.

Witnesses:

GEO. L. WHEELOCK,  
A. SEBRING.