



US 20060066034A1

(19) **United States**

(12) **Patent Application Publication**  
**Terao et al.**

(10) **Pub. No.: US 2006/0066034 A1**

(43) **Pub. Date: Mar. 30, 2006**

(54) **SHEET POST-PROCESS APPARATUS**

(30) **Foreign Application Priority Data**

(75) Inventors: **Yasunobu Terao**, Shizuoka-ken (JP);  
**Tokihiko Ise**, Shizuoka-ken (JP);  
**Hajime Yamamoto**, Shizuoka-ken (JP);  
**Reiji Murakami**, Kanagawa-ken (JP);  
**Hiroyuki Taki**, Shizuoka-ken (JP)

Sep. 29, 2004 (JP) ..... 2004-285348  
Jan. 14, 2005 (JP) ..... 2005-008119

**Publication Classification**

(51) **Int. Cl.**  
**B65H 33/04** (2006.01)  
(52) **U.S. Cl.** ..... **270/58.11**

Correspondence Address:  
**FOLEY AND LARDNER LLP**  
**SUITE 500**  
**3000 K STREET NW**  
**WASHINGTON, DC 20007 (US)**

(57) **ABSTRACT**

A sheet post-process apparatus of the present invention has a standby tray for stably dropping sheets of paper onto a processing tray, so that a pair of tray members for loading ejected sheets of paper is formed so as to project from the wall face of the standby tray and the loading face of sheets of paper is narrowed from the front end side of the sheets of paper toward the rear end side thereof.

(73) Assignee: **TOSHIBA TEC KABUSHIKI KAISHA**

(21) Appl. No.: **11/085,226**

(22) Filed: **Mar. 22, 2005**

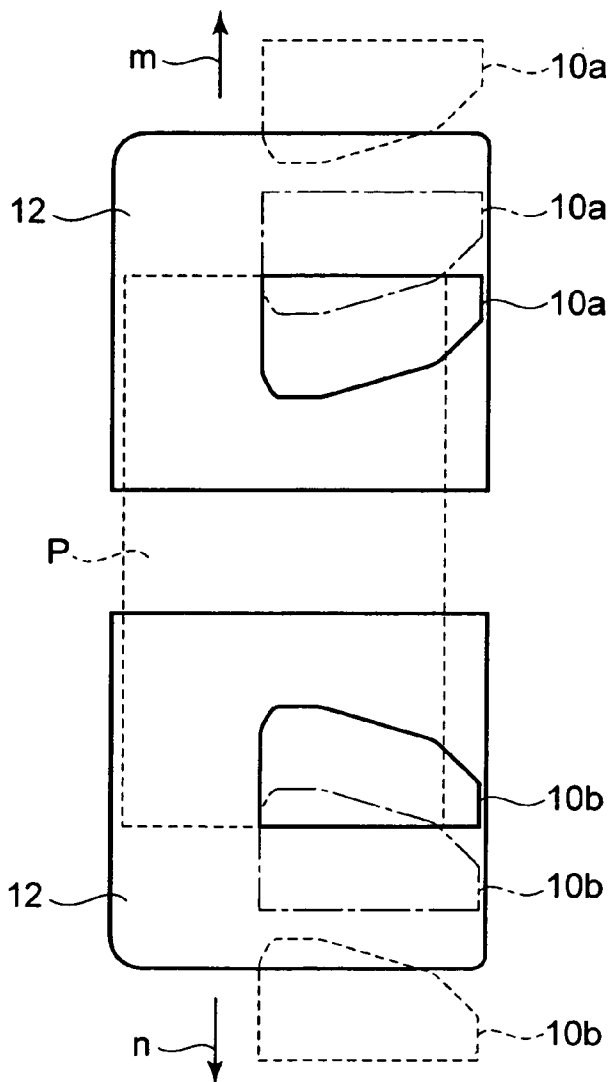

Fig. 1

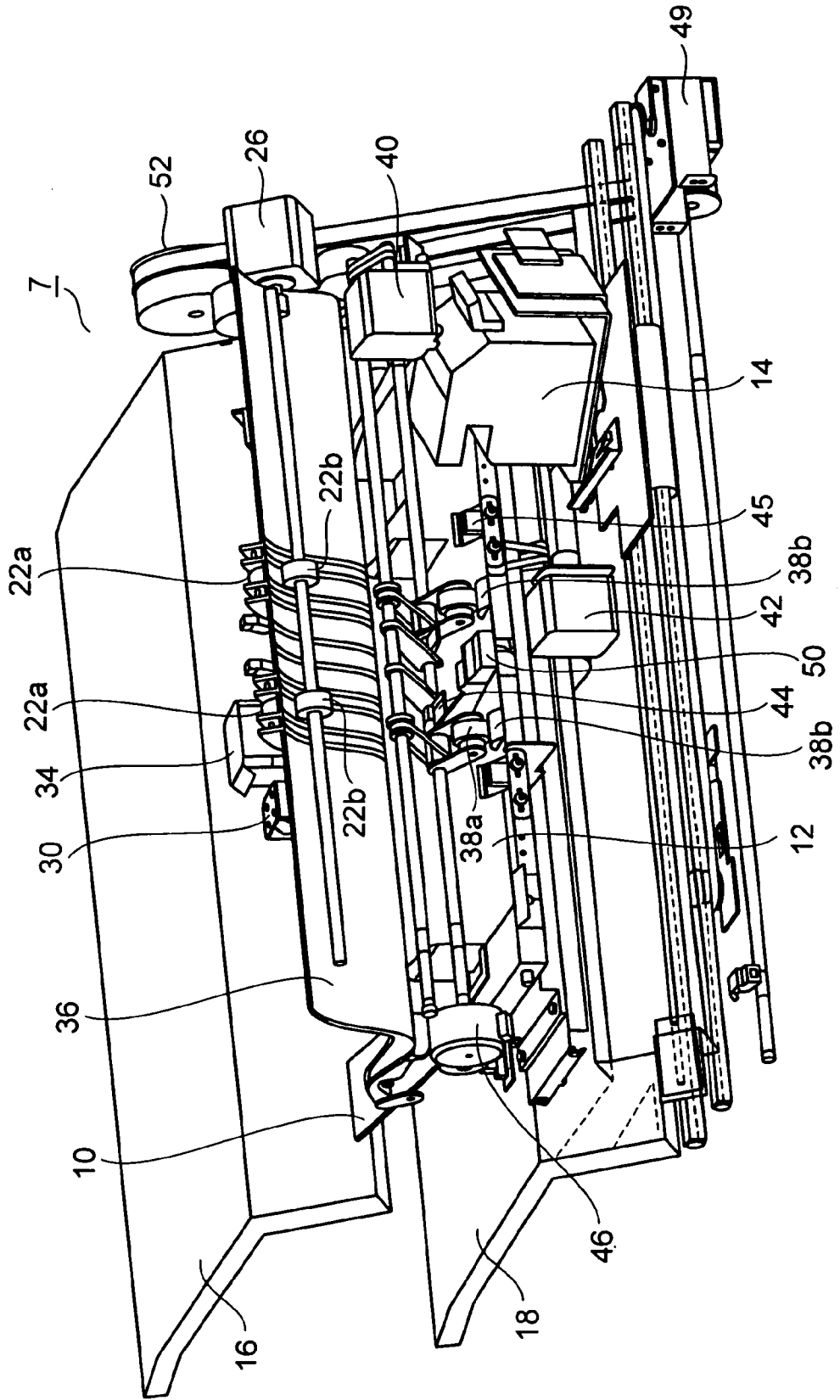

Fig. 2

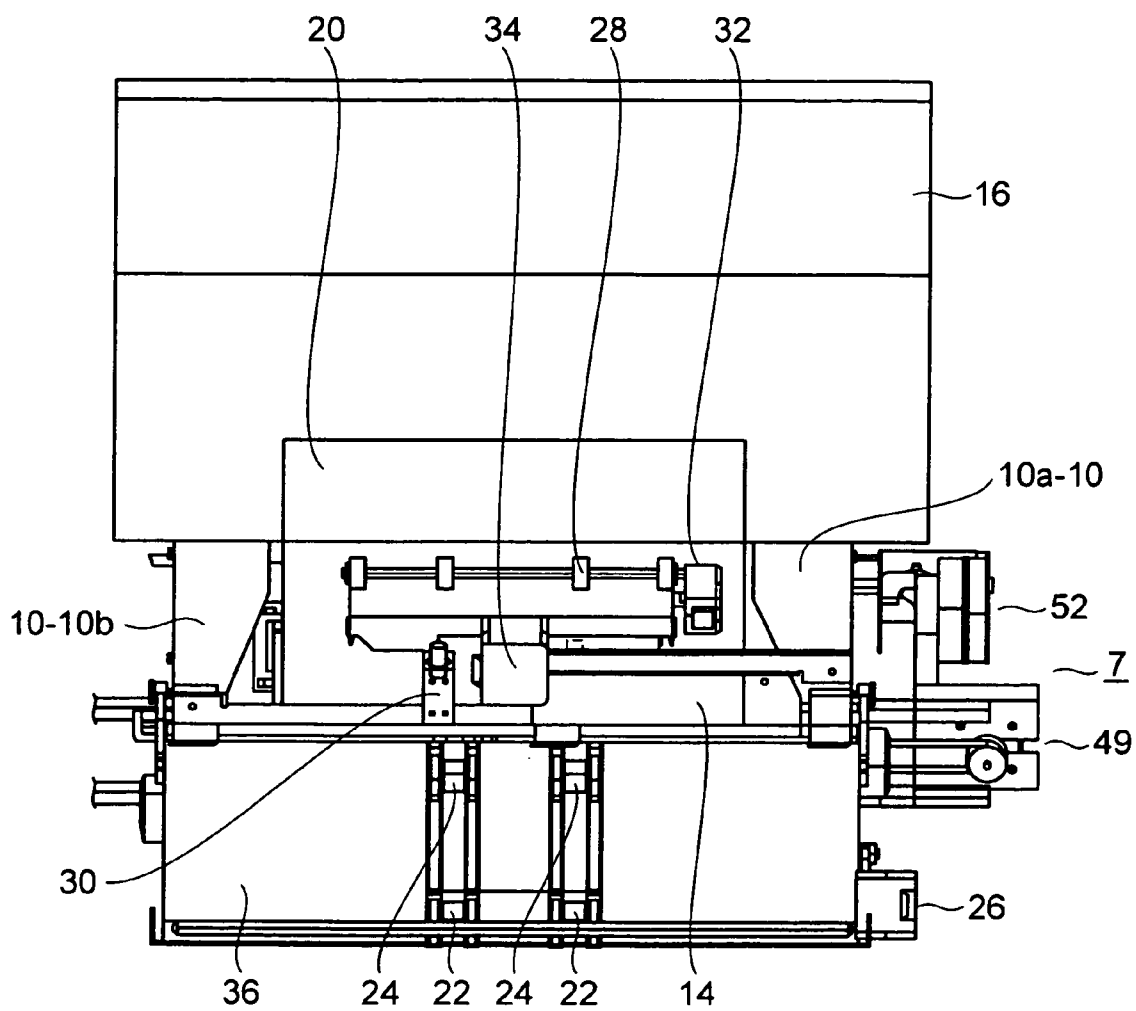



Fig. 4

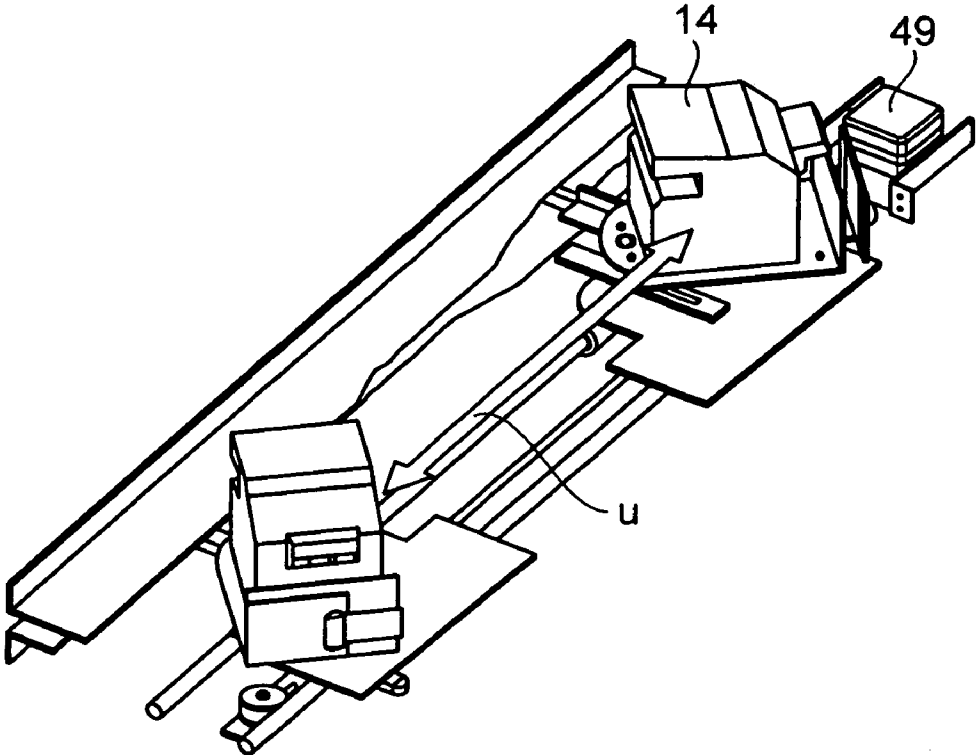
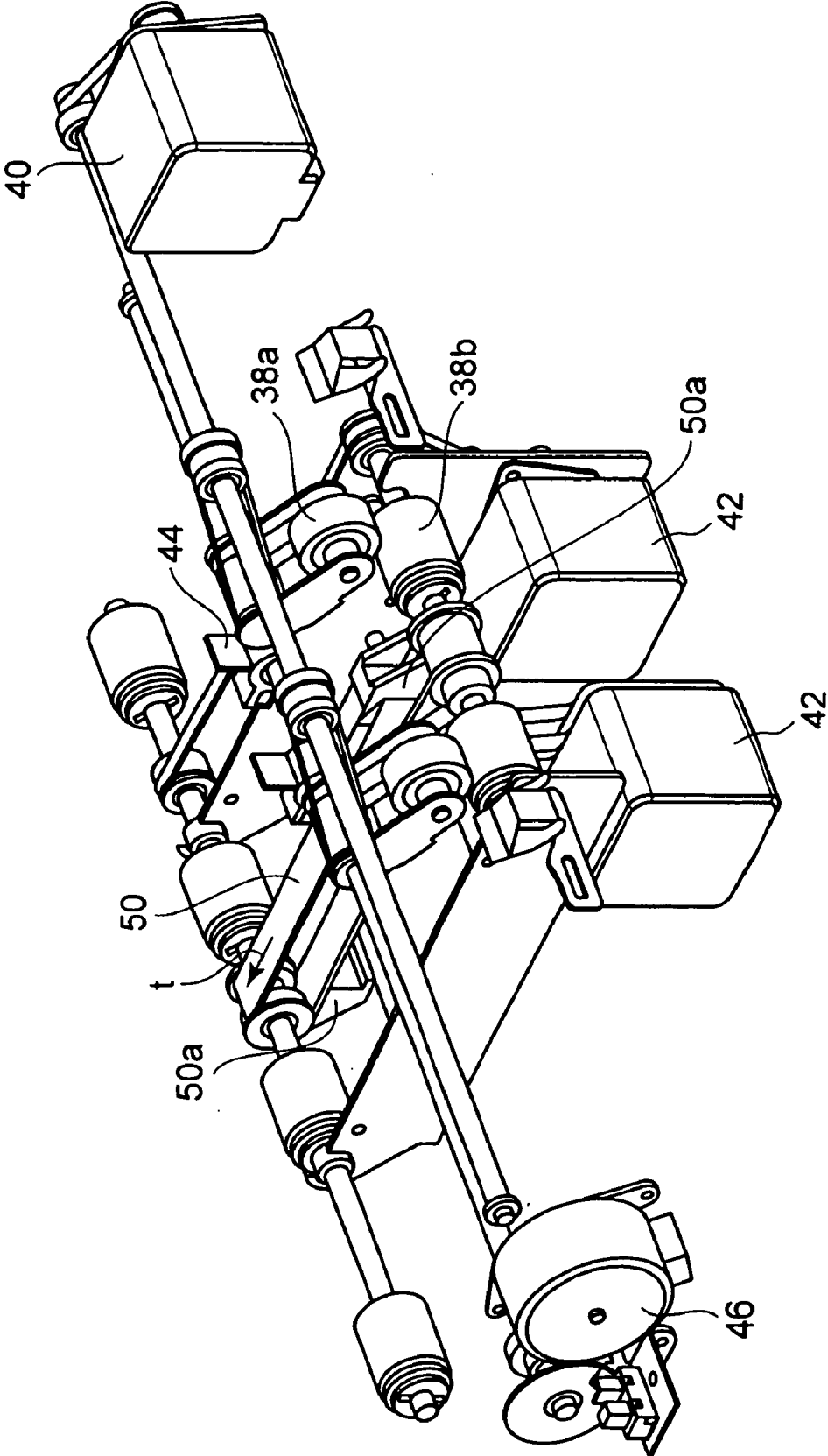

Fig. 5



# Fig. 6

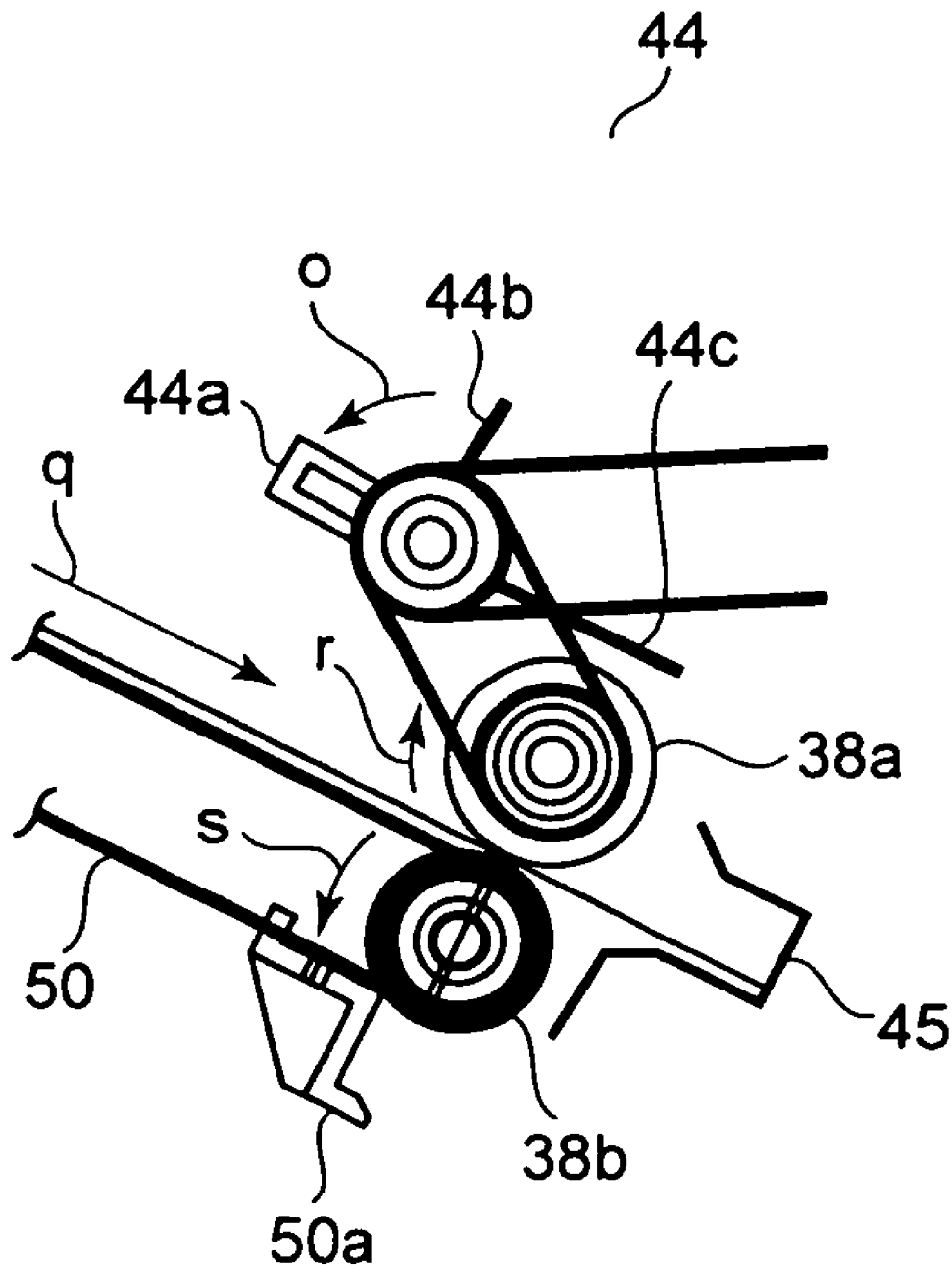
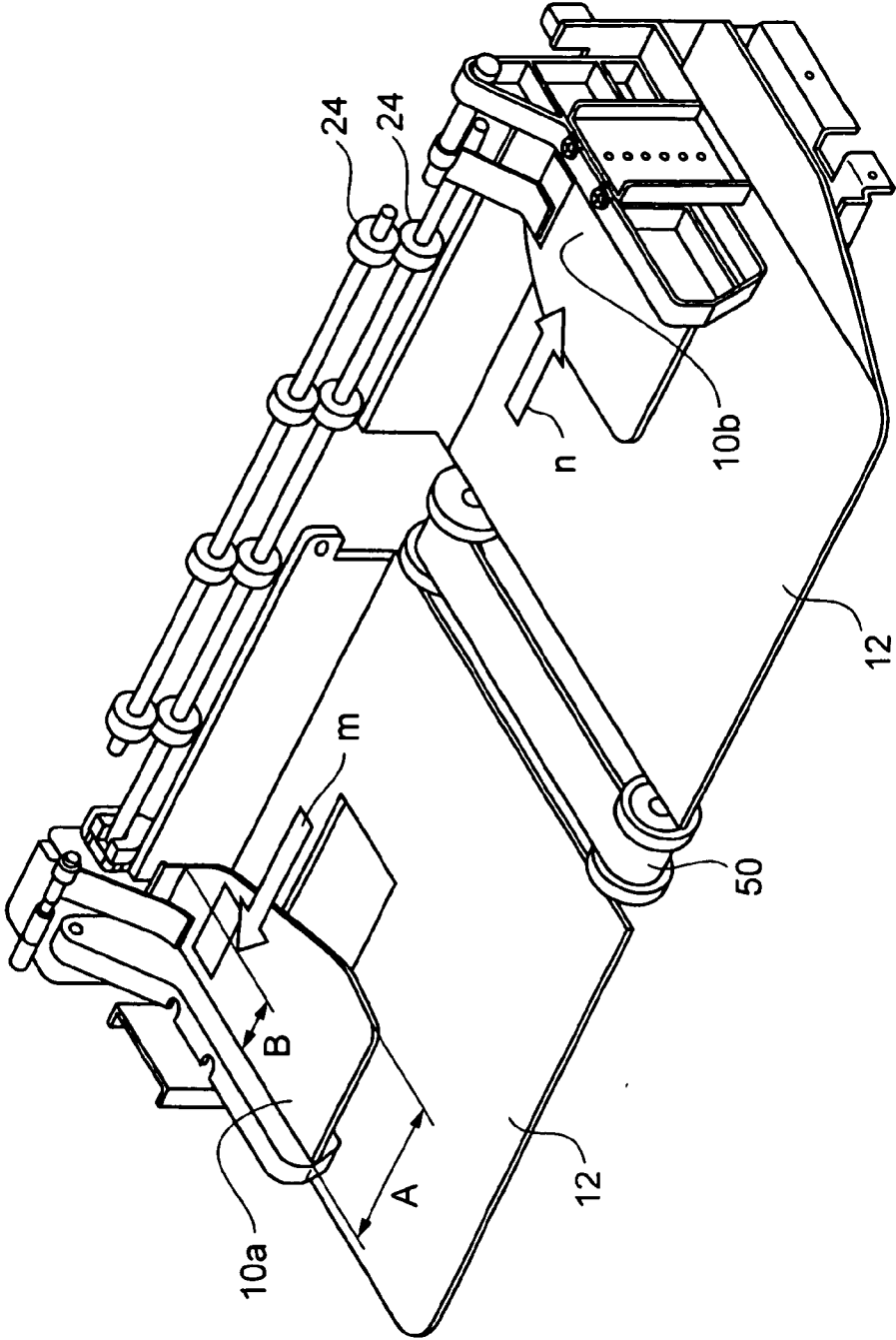

FIG. 7





# Fig. 8

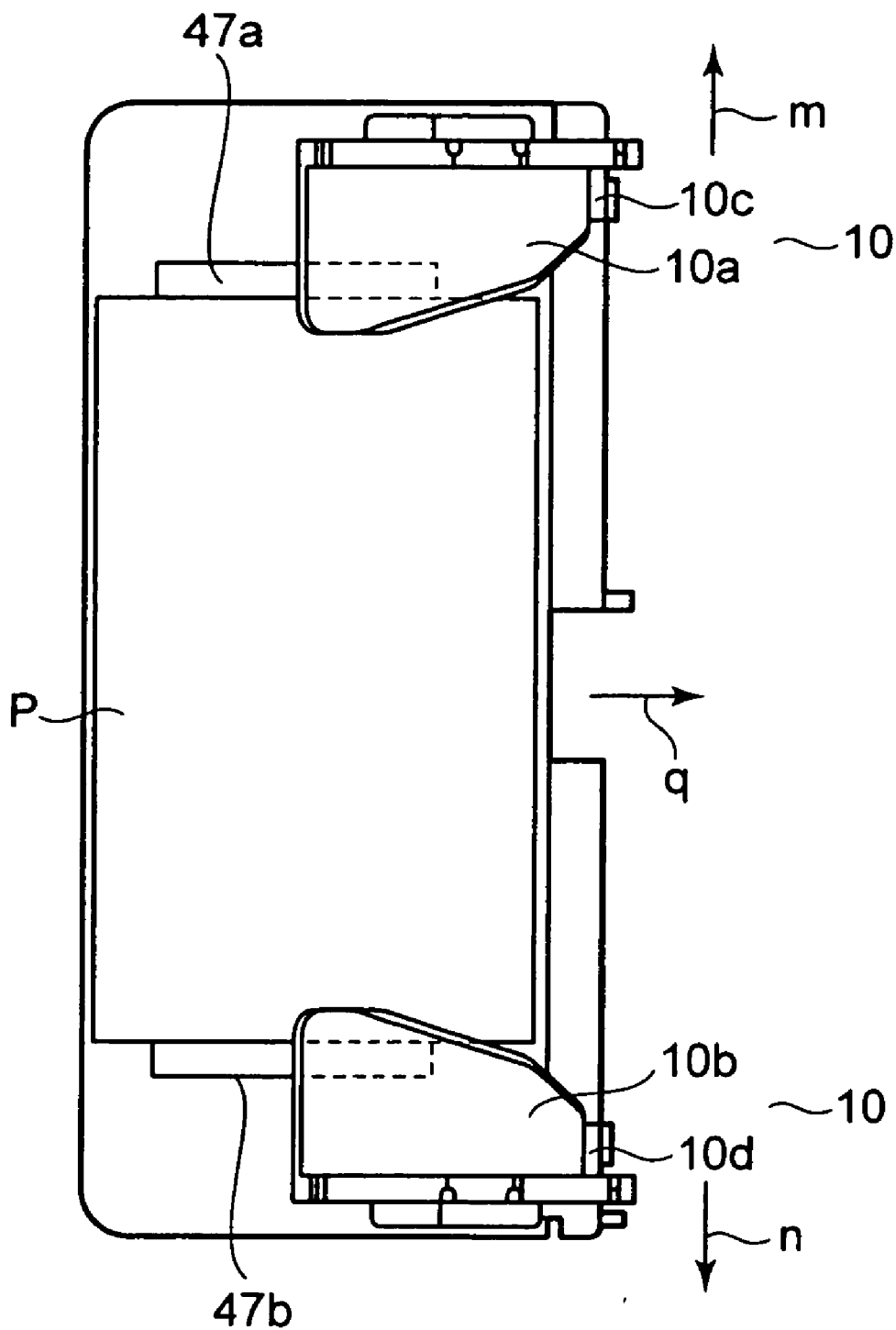

Fig. 9

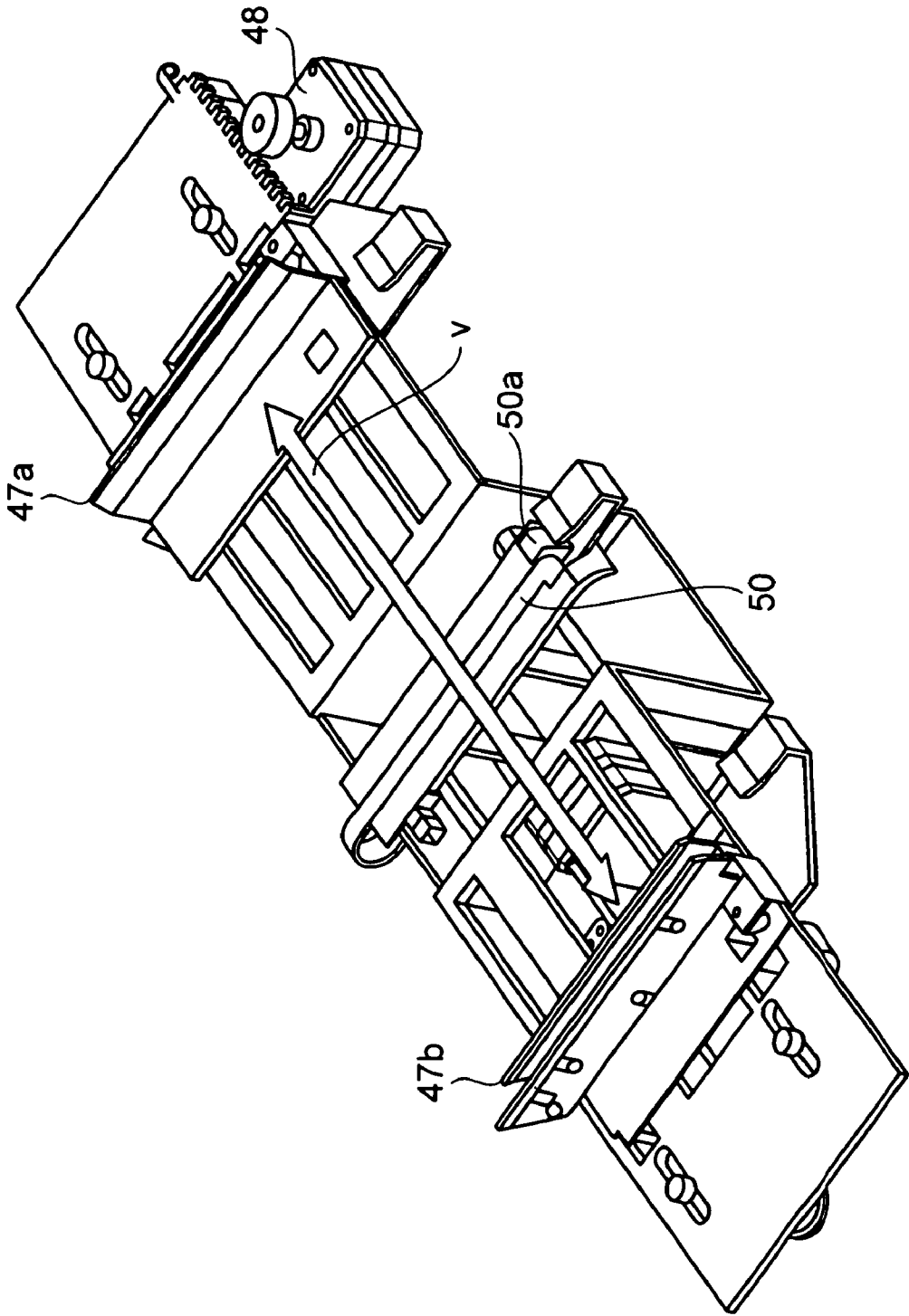
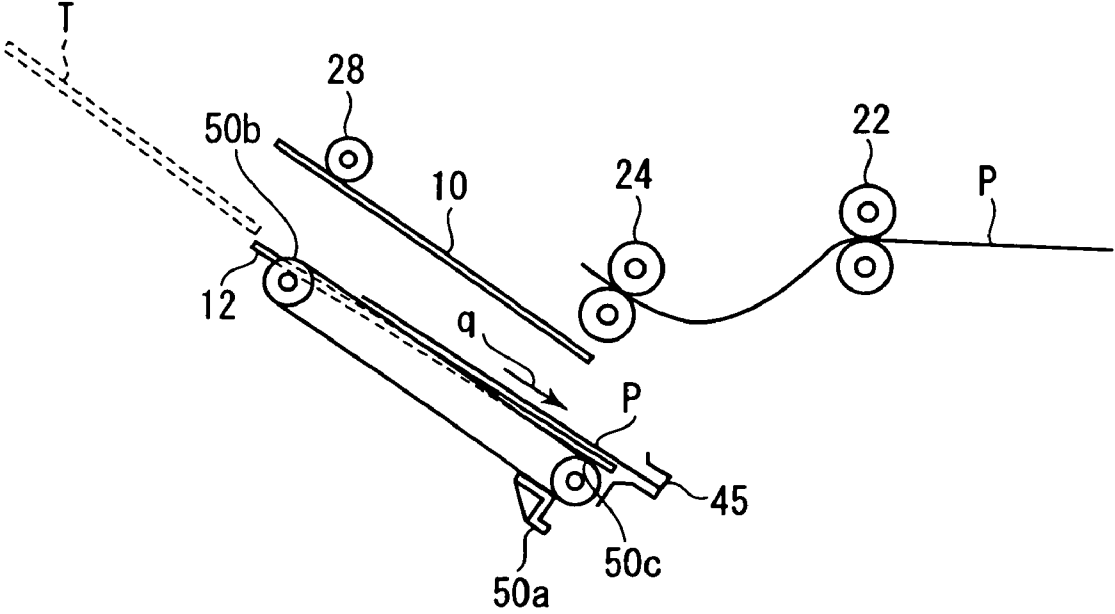
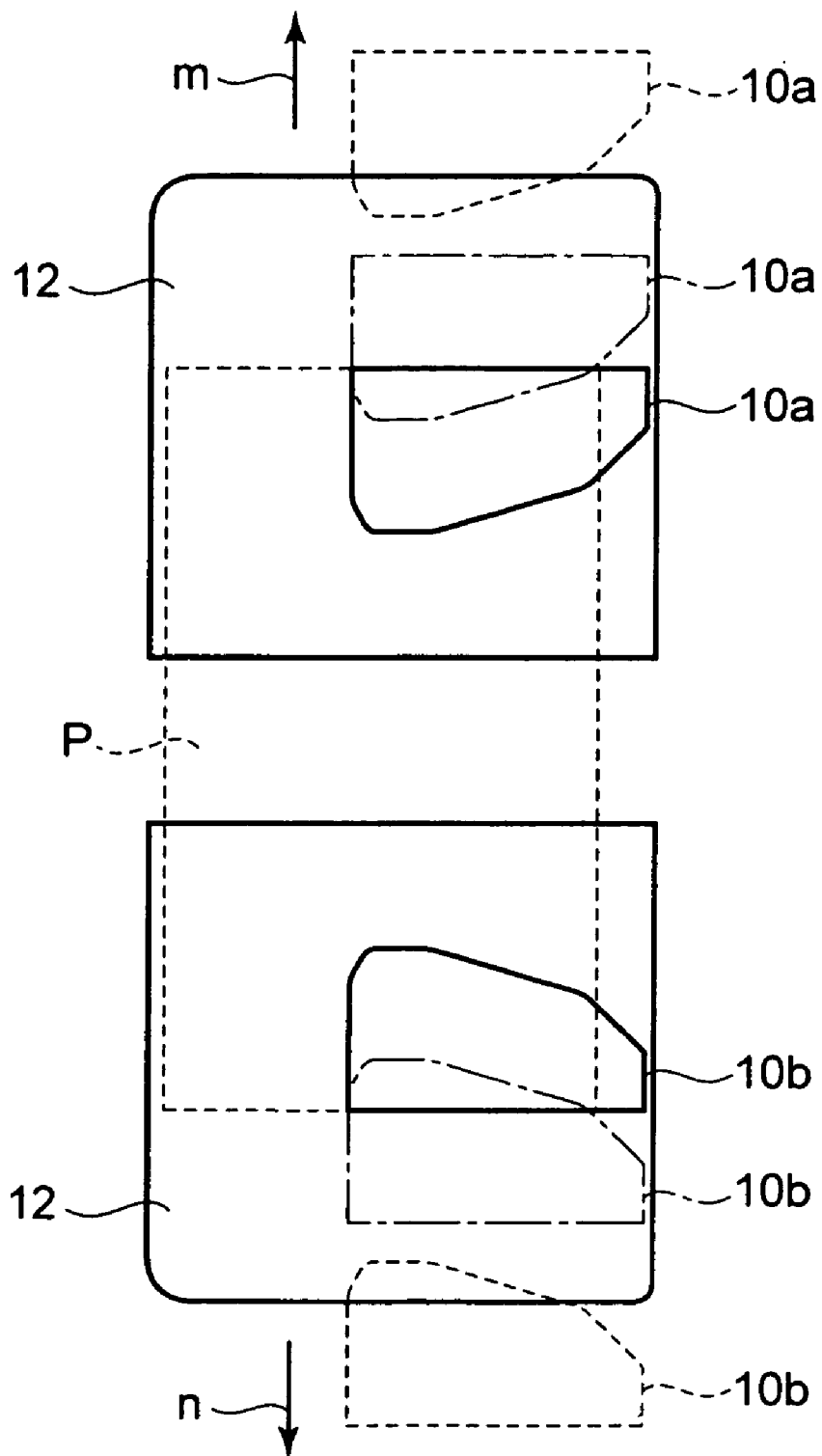

Fig. 10



# Fig. 11



## SHEET POST-PROCESS APPARATUS

### CROSS-REFERENCE TO RELATED APPLICATIONS

[0001] This application is based upon and claims the benefit of priority from the prior Japanese Patent Applications No. 2004-285348, filed on 29th Sep. 2004 and No. 2005-008119, filed on 14th Jan. 2005, the entire contents of which are incorporated herein by reference.

### BACKGROUND OF THE INVENTION

[0002] 1. Field of the Invention

[0003] The present invention relates to a sheet post-process apparatus for post-processing sheets of paper ejected from an image forming apparatus such as a copier, a printer, or a composite device.

[0004] 2. Description of the Related Art

[0005] In recent years, in an image forming apparatus, to post-process sheets of paper after image forming such as sorting or stapling sheets of paper, a sheet post-process apparatus may be installed in the neighborhood of the paper ejection unit of the image forming apparatus body. In such a sheet post-process apparatus, after waiting for ending of the sheet post-process of preceding sheets, the post-process of succeeding sheets is performed. To make the succeeding sheets ejected from the image forming apparatus body stand by like this, conventionally, a shifting path such as a standby tray may be installed halfway the path toward the stapling unit (For example, Japanese Patent Application No. 2004-142868).

[0006] However, in the conventional standby tray, sheets of paper are freely dropped onto the processing tray, though the dropping tendency of sheets of paper is not stable.

### DESCRIPTION OF THE DRAWINGS

[0007] **FIG. 1** is a perspective view showing the essential section of the sheet post-process apparatus relating to an embodiment of the present invention.

[0008] **FIG. 2** is a top view showing the essential section of the sheet post-process apparatus relating to an embodiment of the present invention.

[0009] **FIG. 3** is a schematic block diagram showing the sheet post-process apparatus relating to an embodiment of the present invention.

[0010] **FIG. 4** is a perspective view showing the stapler of the sheet post-process apparatus relating to an embodiment of the present invention.

[0011] **FIG. 5** is a perspective view showing the vertical matching roller relating to an embodiment of the present invention.

[0012] **FIG. 6** is an illustration showing the paddle relating to an embodiment of the present invention.

[0013] **FIG. 7** is a schematic perspective view showing the standby tray and processing tray relating to an embodiment of the present invention.

[0014] **FIG. 8** is a top view showing the standby tray and processing tray relating to an embodiment of the present invention.

[0015] **FIG. 9** is a schematic perspective view showing the horizontal matching plate and conveyor belt relating to an embodiment of the present invention.

[0016] **FIG. 10** is an illustration showing the state of pressed-out sheets on the standby tray or paper ejection tray relating to an embodiment of the present invention.

[0017] **FIG. 11** is an illustration showing movement of the standby tray relating to an embodiment of the present invention.

### DETAILED DESCRIPTION OF THE INVENTION

[0018] Throughout this description, the embodiments and examples shown should be considered as exemplars, rather than limitations on the apparatus and methods of the present invention.

[0019] Hereinafter, the embodiment of the present invention will be explained in detail with reference to the accompanying drawings.

[0020] Further, to the same parts shown in the drawings, the same numerals are assigned and duplicated explanation will be omitted. **FIG. 1** is a perspective view showing the essential section of a sheet post-process apparatus 7 relating to an embodiment of the present invention, and **FIG. 2** is a top view of the essential section of the sheet post-process apparatus relating to an embodiment of the present invention, and **FIG. 3** is a schematic block diagram showing the sheet post-process apparatus 7 arranged in the neighborhood of an image forming apparatus 5 such as a copier.

[0021] The sheet post-process apparatus 7 is basically composed of a standby tray 10, a processing tray 12, a stapler 14, a first paper ejection tray 16, and a second paper ejection tray 18.

[0022] A sheet of paper P on which an image is formed by the image forming apparatus 5 such as a copier and which is ejected by a pair of paper ejection rollers 6 is received by a pair of entrance rollers 22, is fed to a pair of paper feed rollers 24, and is sent to the standby tray 10 from the paper feed rollers 24. The entrance rollers 22 are driven by an entrance roller motor 26. Between the entrance rollers 22 and the standby tray 10, a paper path ceiling 36 for leading the paper P to the paper feed rollers 24 is installed. The entrance rollers 22 are composed of an upper entrance roller 22a and a lower entrance roller 22b. The paper feed rollers 24 are also composed of an upper paper feed roller and a lower paper feed roller.

[0023] Under the standby tray 10, the processing tray 12 for loading the sheets of paper P dropped and fed from the standby tray 10 is arranged.

[0024] The processing tray 12, while the sheets of paper P are stapled by the stapler 14 which is a processing mechanism for performing the post-process, matches and supports the sheets of paper P to be loaded.

[0025] As shown in **FIG. 7**, when a predetermined number of sheets of paper is accumulated on the standby tray 10, standby tray parts 10a and 10b are opened left and right on the drawing by a standby tray motor 34 and the sheets of paper P are dropped by their own weight on the processing tray 12.

[0026] As shown in FIG. 4, the stapler 14 is positioned by a stapler driving unit 49 and the stapling process is controlled. The processing tray 12 has a pair of upper vertical matching roller 38a and lower vertical roller 38b for matching a plurality of sheets of paper P dropped and fed from the standby tray 10 in the vertical direction which is a conveying direction (refer to FIG. 5). The upper and lower vertical matching rollers 38a and 38b serve as bundle conveying rollers for holding a paper bundle T after stapled and taking out it from the stapler 14. The upper vertical matching roller 38a is driven by a vertical matching upper roller motor 40. The lower vertical matching roller 38b is driven by a vertical matching lower roller motor 42.

[0027] When the sheets of paper P are dropped and fed on the processing tray 12, at the position where the rear end of each of the sheets of paper P is dropped, a rotatable paddle 44 for matching vertically the uppermost sheet of paper P loaded on the processing tray 12 is arranged. The paddle 44, as shown in FIG. 6, has a receiving portion 44a of the sheets of paper P dropped and fed onto the processing tray 12, a beating portion 44b for beating down the sheets of paper P on the processing tray 12, and a feeding portion 44c for matching the sheets of paper P on the processing tray 12 and it is driven by a paddle motor 46. The paddle 44 is composed of an elastic rubber material.

[0028] At the end of the processing tray 12 on the side of the stapler 14, a stopper 45 for making contact with the rear end of each of the sheets of paper P and controlling the rear end position. Almost at the center of the processing tray 12, a conveyor belt 50 for conveying the paper bundle T, which is stapled and taken out from the stapler 14 by the upper and lower vertical matching rollers 38a and 38b, up to the first or second paper ejection tray 16 or 18 is installed. To the conveyor belt 50, a feed pawl 50a for hooking the rear end of the paper bundle T is attached.

[0029] The standby tray 10 can drop and feed the sheets of paper P onto the processing tray 12 and also can convey the sheets of paper P toward the first or second paper ejection tray 16 or 18. When conveying the sheets of paper P toward the paper ejection trays 16 and 18, a standby tray roller 28 for matching the sheets of paper P makes contact with the sheets of paper P on the standby tray 10. The standby tray roller 28 is controlled in the vertical movement by a standby tray roller driving source 30 and is driven to rotate by a standby tray roller motor 32.

[0030] The standby tray 10 supports the sheets of paper P so as to position the front ends thereof higher than the rear ends thereof, so that it is arranged at a tilt angle of  $\theta 1$ . The first or second paper ejection tray 16 or 18 is moved up and down by a paper ejection tray driving unit 52 and either of them is selected. The first or second paper ejection tray 16 or 18 is moved up and down up to almost the same height as that of the standby tray 10 or the processing tray 12 when loading the sheets of paper P to improve the consistency of the sheets of paper P to be ejected. The first or second paper ejection tray 16 or 18 supports the sheets of paper P so as to position the front ends thereof higher than the rear ends thereof, so that they are arranged at a tilt angle of  $\theta 2$ .

[0031] As shown in FIGS. 7 and 8, the standby tray 10 has a pair of tray members 10a and 10b formed so as to project from the wall face thereof, receives the sheets in a state that it slides in the width of the paper P and supports

both sides of the paper P. On the tray members 10a and 10b, standby stoppers 10c and 10d for controlling the rear ends of the sheets of paper P are installed.

[0032] When the sheets of paper P have poor posture on the standby tray 10, the standby tray 10 cannot feed the sheets of paper P to the processing tray 12 or cannot process them.

[0033] Therefore, to keep the sheets of paper P in a stable posture on the standby tray 10, the tray members 10a and 10b may rotate upward and downward at the fulcrums of the joined parts with the standby tray 10.

[0034] The tray members 10a and 10b of the standby tray 10 slide and move horizontally and the sheets of paper P are freely dropped onto the processing tray. However, when the supporting width of sheets of paper by the tray members 10a and 10b is almost uniform in the vertical direction (the conveying direction), the dropping tendency of sheets of paper is not stable and the direction is varied. The sheets of paper P sent to the processing tray are matched, though when they are dropped variably, it takes time for the sheets of paper to be lined up. Furthermore, it takes time to eject the sheets of paper after processing them.

[0035] Therefore, as shown in FIG. 7, in the tray members 10a and 10b, the loading width of sheets of paper is not uniform and is narrowed on the rear end side of sheets of paper. For example, the support width of the tray members 10a and 10b on the rearmost side of sheets of paper is almost equal to the width of the standby stoppers 10c and 10d at most.

[0036] When the tray members 10a and 10b slide and start to open, since the support range on the rear end side of sheets of paper is narrow, the sheets of paper P are dropped starting from the rear end side.  $A > B$ , so that the sheets of paper P are dropped onto the processing tray from the rear end side.

[0037] Since the sheets of paper P are dropped from the rear end side, the sheets of paper can be easily lined up to perform the stapling process.

[0038] The standby tray 10 slides and moves by the standby tray motor 34. Between the standby tray 10 and the processing tray 12 where it reaches, when dropping and feeding the sheets of paper P from the standby tray 10 onto the processing tray 12, horizontal matching plates 47a and 47b shown in FIG. 9 for preventing the sheets of paper P from turning away in the horizontal direction perpendicular to the conveying direction and matching them horizontally are installed. The horizontal matching plates 47a and 47b are formed slidably so as to fit to the width of the sheets of paper P by a horizontal matching motor 48.

[0039] Next, the operation of the invention will be described. When an image is formed by the image forming apparatus 5 and a sheet of paper P is fed from the paper ejection rollers 6, the sheet post-process apparatus 7, depending on a case of performing the post-process of the sheet of paper P or a case of performing no post-process, or while the preceding sheet of paper P is in execution of the post-process or the post-process is finished, performs a different operation.

[0040] When the post-process is not to be performed, for example, the first paper ejection tray 16 slides and moves to the position indicated by a dotted line shown in FIG. 3 and

can load the sheets of paper P ejected from the standby tray 10 in good consistency. When the post-process is not to be performed, the sheet of paper 10 conveyed from the entrance rollers 22 to the paper feed rollers 24 via the paper path ceiling 36 is fed to the standby tray 10 by the paper feed rollers 24. Then, the sheet of paper P is moved down onto the standby tray 10, is conveyed by the standby tray 28 rotating in the direction of an arrow f, and is fed to the first paper ejection tray 16.

[0041] In this way, on the first paper ejection tray 16, sheets of paper are sequentially loaded. The first paper ejection tray 16 is arranged at a tilt angle of  $\theta_2$  and the front end of the sheet of paper is positioned higher than the rear end thereof, so that for example, even if the sheet of paper P is fed to the first paper ejection tray 16 in a state that it is curled convexly as shown by a dotted line in FIG. 10, the preceding sheet of paper P loaded on the first paper ejection tray 16 is not pressed out by making contact with the front end of the succeeding sheet of paper P. Namely, the ejected sheet of paper P is sequentially loaded on the first paper ejection tray 16 unless the order is disturbed. Even if the preceding sheet of paper P is pressed by the succeeding sheet of paper P and is slightly displaced, since the tilt angle is  $\theta_2$ , the sheet of paper P drops by its own weight and is loaded on the first paper ejection tray 16 with the rear end matched, and the ejection process of the sheet of paper is completed.

[0042] Next, a case that the stapling process which is a post-process is to be performed and no preceding sheet of paper P in execution of the stapling process exists on the processing tray 12 will be described. At this time, the standby tray 10 slides and moves the tray members 10a and 10b respectively up to the positions indicated by the dotted lines in FIG. 11 in the directions of arrows m and n and opens the dropping and feeding path of the sheet of paper P. The horizontal matching plates 47a and 47b, to match the sheet of paper P dropping from the paper feed rollers 24 in the horizontal direction, are arranged so that the gap between the horizontal matching plates 47a and 47b is made almost equal to the width of the sheet of paper P. By doing this, the sheet of paper P fed by the paper feed rollers 24, without the conveying being obstructed by the standby tray 10, is dropped and fed directly onto the processing tray 12.

[0043] At the time of dropping and feeding, the upper vertical matching roller 38a is shifted upward and the receiving portion 44a of the paddle 44 receives the rear end of the sheet of paper P. Both sides of the sheet of paper P drop in contact with the horizontal matching plates 47a and 47b and are matched in the horizontal direction. Then, the paddle 44 rotates in the direction of an arrow o, drops the rear end of the sheet of paper P from the receiving portion 44a, and beats down it onto the processing tray 12 by the beating portion 44b. Furthermore, the paddle 44 feeds the sheet of paper P in the direction of an arrow q by the feeding portion 44c, and the rear end of the sheet of paper P makes contact with the stopper 45, and the vertical matching of the sheet of paper P is completed. Further, the vertical matching of the sheet of paper P on the processing tray 12 may be executed by the upper vertical matching roller 38a by moving up and down each time.

[0044] In this way, the sheet of paper P on which an image is formed is loaded directly on the processing tray 12 from the paper feed rollers 24 while sequentially matching it in

the horizontal direction and vertically direction. When the sheets of paper P reach a predetermined number, the stapler 14 staples the sheets of paper P on the processing tray 12 at a desired position and bundles them to form the paper bundle T. [page 8] Hereafter, the upper vertical matching roller 38a is moved down onto the paper bundle and the paper bundle T is held between the upper vertical matching roller 38a rotating in the direction of the arrow r and the lower vertical matching roller 38b rotating in the direction of the arrow s and is conveyed toward the first paper ejection tray 16. When the rear end of the paper bundle T passes the upper and lower vertical matching rollers 38a and 38b, it is hooked by the feed pawl 50a of the conveyor belt 50 rotating in the direction of the arrow t and is sent onto the first paper ejection tray 16.

[0045] At this time, the first paper ejection tray 16 slides and moves from the position indicated by the dashed line in FIG. 3 to the position indicated by the solid line. The first paper ejection tray 16 is arranged at a tilt angle of  $\theta_2$  and the front end of the sheet of paper is positioned higher than the rear end thereof, so that the preceding sheet of paper P sent onto the first paper ejection tray 16 is not pressed out by making contact with the front end of the succeeding paper bundle T. Further, even if the preceding paper bundle T is slightly displaced by the succeeding sheet of paper P, since the tilt angle is  $\theta_2$ , the paper bundle T drops by its own weight and is loaded on the first paper ejection tray 16 with the rear end matched, and the stapling process of the sheets of paper P is completed.

[0046] Next, a case that the stapling process which is a post-process is to be performed and preceding sheets of paper P in execution of the stapling process remain on the processing tray 12 will be described. At this time, the standby tray 10 slides and moves the tray members 10a and 10b from the position indicated by the dashed line in FIG. 11 respectively in the opposite direction of the direction of the arrow m or in the opposite direction of the direction of the arrow n, and is moved to the position indicated by the solid line shown in FIG. 11, and can support the sheet of paper P. The standby tray roller 28 is shifted above the standby tray not to disturb the sheets of paper P. The sheets of paper P ejected from the image forming apparatus 5 and fed by the paper feed rollers 24 are loaded once on the standby tray 10 to wait for the processing tray 12 to be free.

[0047] The sheets of paper P loaded on the standby tray 10 are moved down onto the standby tray 10, are sent toward the standby stoppers 10c and 10d by the standby tray roller 28 rotating in the opposite direction of the direction of the arrow f, and are vertically matched with the rear end of the sheets of paper P in contact with the standby stoppers 10c and 10d. Furthermore, the first paper ejection tray 16 is arranged at a tilt angle of  $\theta_1$  and the front end of the sheets of paper is positioned higher than the rear end thereof, so that the sheets of paper P are vertically matched by the own weight with the rear end thereof in contact with the standby stoppers 10c and 10d.

[0048] The standby tray 10 is arranged at a tilt angle of  $\theta_1$ , so that for example, even if the sheet of paper P is fed from the paper feed rollers 24 in a state that it is curled convexly and is fed to the standby tray 10, the preceding sheet of paper P loaded on the standby tray 10 is not pressed out by making contact with the front end of the succeeding sheet of paper

P. Namely, the fed sheet of paper P is sequentially loaded on the standby tray 10 unless the order is disturbed. Further, even if the preceding sheet of paper P is pressed by the succeeding sheet of paper P and is slightly displaced, since the tilt angle is  $\theta_1$ , the sheet of paper P drops by its own weight down to the position where the rear end thereof makes contact with the standby stoppers 10c and 10d and is loaded on the standby tray 10 with the rear end matched.

[0049] During this period, when the preceding sheet of paper P on the processing tray 12 is ejected on the side of the paper ejection tray 16 and the processing tray 12 becomes free, the standby tray 10 slides and moves the tray members 10a and 10b respectively up to the positions indicated by the dotted lines in FIG. 11 in the directions of the arrows m and n from the position indicated by the solid line in FIG. 11 via the position indicated by the alternate long and short dash line in FIG. 11. By doing this, for example, two sheets of paper P standing by on the standby tray 10, when the tray members 10a and 10b reach the position indicated by the alternate long and short dash line in FIG. 11, are dropped and fed onto the processing tray 12 from between the tray members 10a and 10b. At this time, the horizontal matching plates 47a and 47b are arranged so as to make the interval between them almost equal to the width of the sheets of paper P. Therefore, the sheets of paper P dropped from the standby tray 10 are controlled on both sides by the horizontal matching plates 47a and 47b and are matched horizontally.

[0050] The lower side sheet of paper P of the two sheets of paper P dropped onto the processing tray 12 is sent in the direction of the arrow q by the lower vertical matching roller 38b rotating in the opposite direction of the direction of the arrow s, and the rear end of the sheet of paper P makes contact with the stopper 45, and the vertical matching of the sheet of paper P is completed. The upper side sheet of paper P of the two sheets of paper P dropped onto the processing tray 12 is sent in the direction of the arrow q by the upper vertical matching roller 38a rotating in the opposite direction of the direction of the arrow r, and the rear end of the sheet of paper P makes contact with the stopper 45, and the vertical matching of the sheet of paper P is completed, and thereafter, the upper vertical matching roller 38a is shifted upward.

[0051] The third and subsequent sheets of paper P ejected from the image forming apparatus 5 are directly dropped and fed onto the processing tray 12 from between the tray members 10a and 10b without standing by on the standby tray 10. Hereafter, the third and subsequent sheets of paper P are sequentially matched on the sheets of paper P loaded earlier on the processing tray 12 by the paddle 44.

[0052] When the sheets of paper P loaded on the processing tray 12 reach a predetermined number, the sheets are stapled by the stapler 14 to form a paper bundle T. Hereafter, the paper bundle T is conveyed toward the first paper ejection tray 16 by the upper and lower vertical matching rollers 38a and 38b, and furthermore the rear end thereof is hooked by the feed pawl 50a of the conveyor belt 50, and the paper bundle is sent to the first paper ejection tray 16, and the stapling process of the sheets of paper P is completed.

[0053] In this embodiment having such a constitution, when the stapling process is to be performed after image forming and the preceding stapling process is not finished on the processing tray 12, the standby tray 10 is installed above

the processing tray 12 and waits for the succeeding sheets of paper P. And, waiting for the processing tray 12 to become free, the sheets of paper P standing by on the standby tray 10 are dropped and fed and then are moved to the processing tray 16. Therefore, the practical conveying path from the standby tray 10 in the sheet post-process apparatus 7 to the processing tray 12 can be shortened and the sheet post-process apparatus can be miniaturized.

[0054] Further, the standby tray 10 is given a tilt angle of  $\theta_1$ , thus the sheets of paper P can be matched by the own weight on the standby tray 10. There is no fear that the sheet of paper P loaded earlier is pressed out by the succeeding sheet of paper P, and the consistency of the sheets of paper P on the standby tray 10 can be improved, and the sheets of paper P can be prevented from jamming, and the loading order of the sheets of paper P on the standby tray 10 can be prevented from disturbance. Similarly, the first or second paper ejection tray 16 or 18 is given a tilt angle of  $\theta_2$ , thus there is no fear that the sheets of paper P or the paper bundle T earlier loaded on the first or second paper ejection tray 16 or 18 is pressed out by the succeeding sheets of paper P or paper bundle T, and the consistency of the sheets of paper P on the first or second paper ejection tray 16 or 18 can be improved, and the sheets of paper P can be prevented from jamming, and furthermore the loading order of sheets of paper P or the paper bundle T on the first or second paper ejection tray 16 or 18 can be prevented from disturbance.

[0055] Further, in the present invention, as a post-process to be performed for sheets of paper loaded on the processing tray, the stapling process is described. However, the post-process is not limited to a case of stapling sheets of paper and for example, a post-process such as a hole-punching process in sheets of paper is not questionable. In this case, with respect to sheets of paper loaded on the processing tray, loading of one sheet instead of a plurality of sheets of paper provides no trouble. Needless to say, for a post-process apparatus having such a post-processing mechanism, the present invention produces an effect.

[0056] Although exemplary embodiments of the present invention have been shown and described, it will be apparent to those having ordinary skill in the art that a number of changes, modifications, or alterations to the invention as described herein may be made, none of which depart from the spirit of the present invention. All such changes, modifications, and alterations should therefore be seen as within the scope of the present invention.

What is claimed is:

1. Sheet post-process apparatus comprising:

- a standby tray for making sheets ejected from an image forming apparatus stand by,
- a processing tray arranged under said standby tray for loading said sheets dropped and fed from said standby tray and/or said sheets ejected from said image forming apparatus not via said standby tray,
- a processing mechanism for post-processing said sheets loaded on said processing tray, and
- a paper ejection tray for loading said sheets ejected from said processing tray after ending of said post process, wherein:



said standby tray is formed so that a pair of tray members for loading said ejected sheets are projected from a wall face of said standby tray and a sheet loading face is narrowed from a front side of said sheets toward a rear side thereof.

2. The sheet post-process apparatus of claim 1, wherein:

said pair of tray members can rotate upward and downward at a fulcrum of a joined part with said standby tray.

3. The sheet post-process apparatus of claim 1, wherein:

said standby tray has a standby stopper for controlling said rear end side of said sheets.

4. The sheet post-process apparatus of claim 3, wherein:

in said pair of tray members, a support width of said sheets on a farthest rear end side is almost equal to a width of said standby stopper.

5. The sheet post-process apparatus of claim 3, wherein:

said standby tray and said standby stopper are formed integrally with each other.

6. The sheet post-process apparatus of claim 1, wherein:

said pair of tray members have round corners.

7. The sheet post-process apparatus of claim 1, wherein:

in said pair of tray members, a part equivalent to about  $\frac{1}{3}$  of a length thereof from said front end side of said sheets has an almost same width and a residual about  $\frac{2}{3}$  is narrowed gradually toward said rear end side of said sheets.

\* \* \* \* \*