

G. B. ANDERSON.
PNEUMATIC MOTOR.

(Application filed Aug. 2, 1901.)

(No Model.)

3 Sheets—Sheet 1.

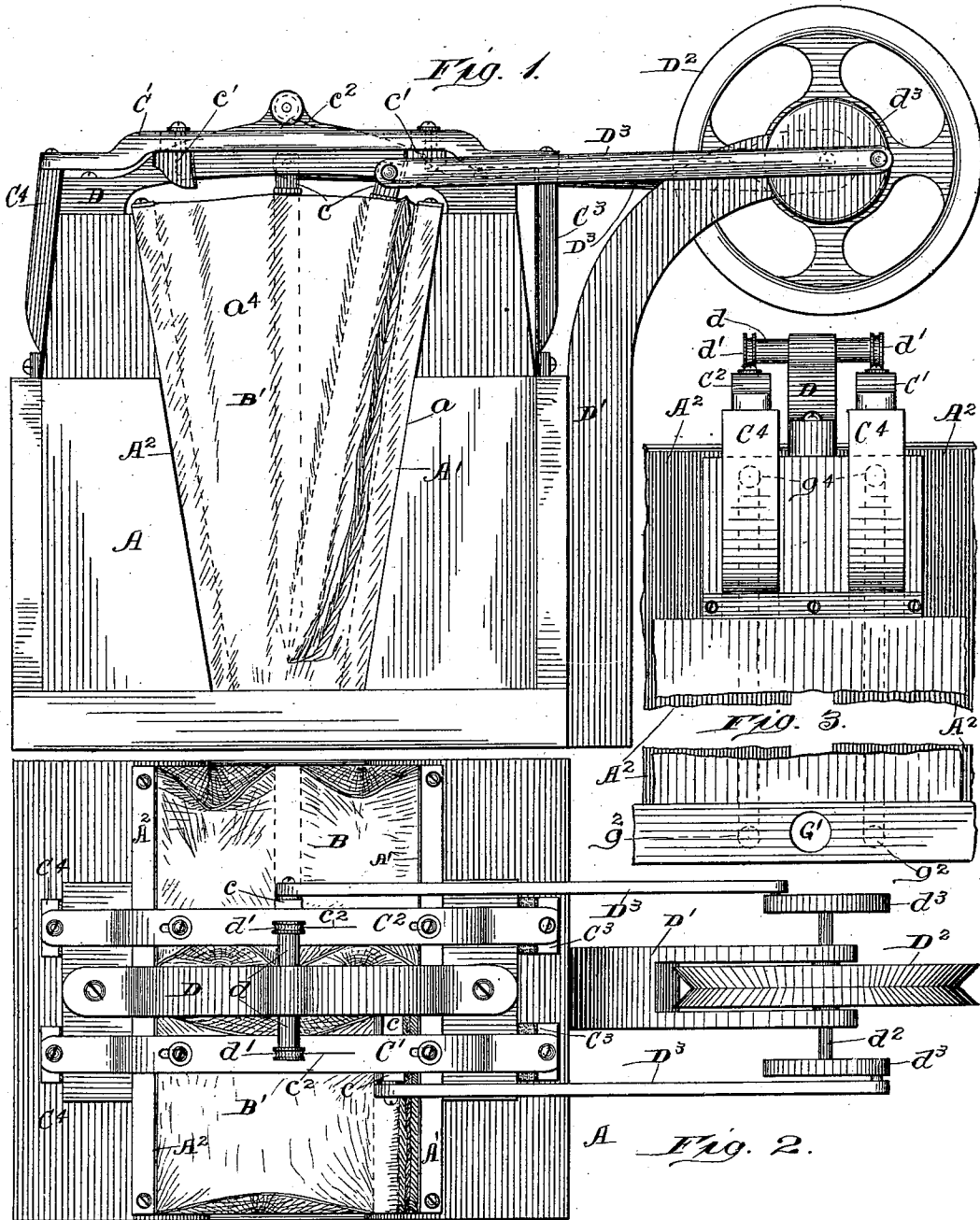

Witnesses:
 Chas. E. Gordon,
 H. A. Thomas.

Inventor:
 Gustaf B. Anderson
 By Chas. C. Fillman, Att'y.

G. B. ANDERSON.
PNEUMATIC MOTOR.

(Application filed Aug. 2, 1901.)

(No Model.)

3 Sheets—Sheet 2.

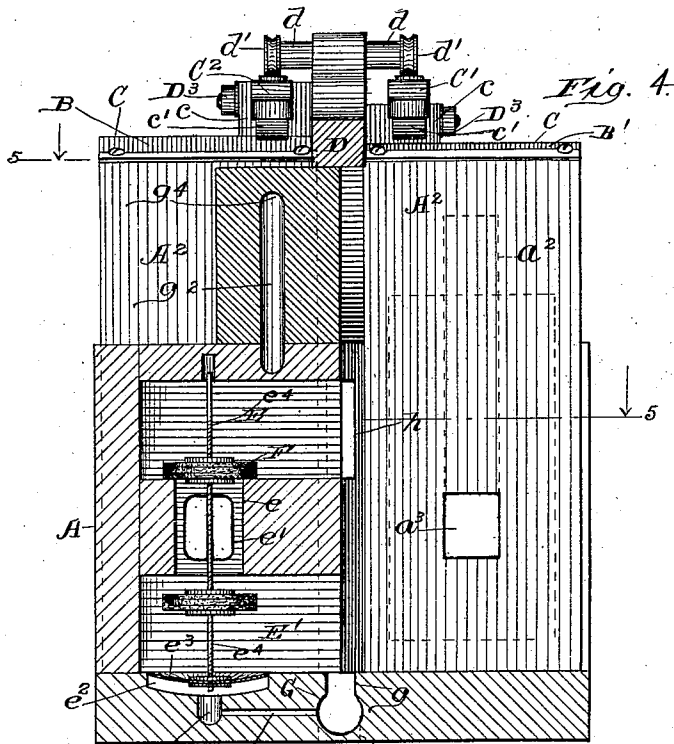

Fig. 4.

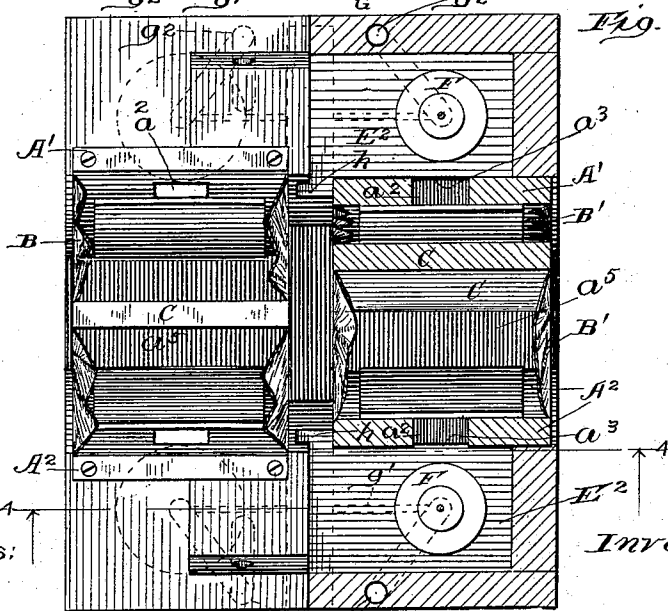

Fig. 5.

Witnesses:

Inventor:

Chas. E. Gordon,
H. A. Thomas,

Gustaf B. Anderson
BY *Chas. C. Tillman* Attor.

G. B. ANDERSON.
PNEUMATIC MOTOR.

(Application filed Aug. 2, 1901.)

(No Model.)

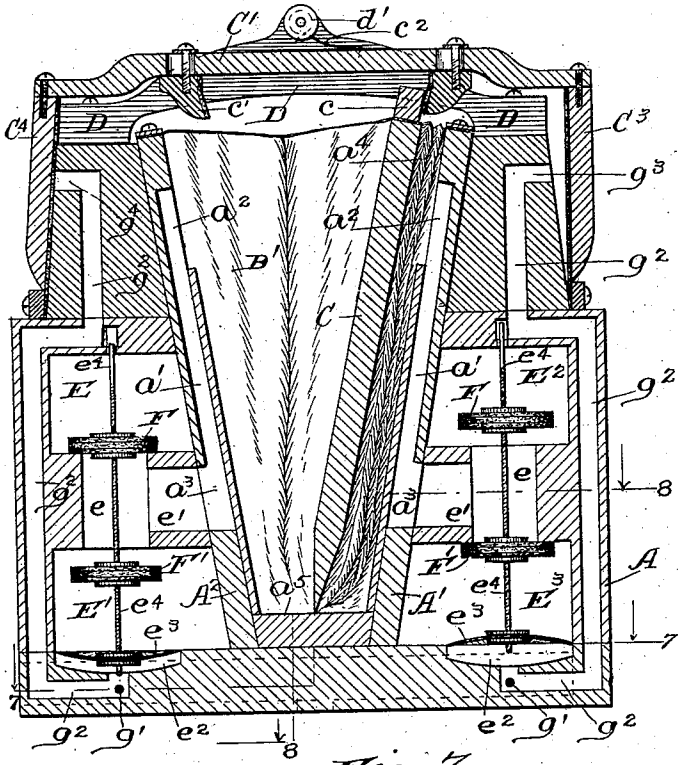
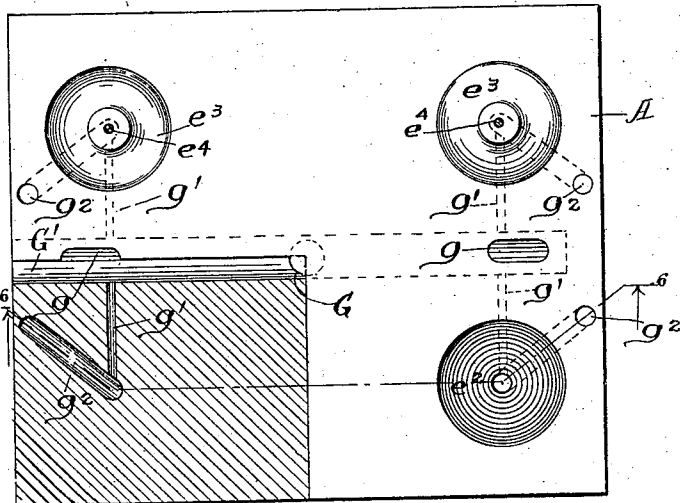
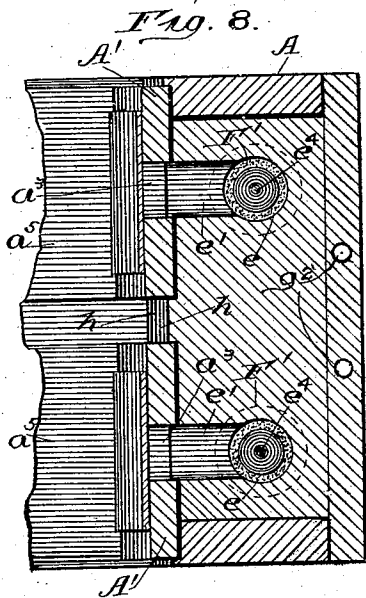

Fig. 7.

Fig. 6.



Witnesses:

Cas. E. Gorton.
H. A. Thomas.

Inventor:

Gustaf B. Anderson
By *Chas. C. Tillman* Atty.

UNITED STATES PATENT OFFICE.

GUSTAF B. ANDERSON, OF CHICAGO, ILLINOIS.

PNEUMATIC MOTOR.

SPECIFICATION forming part of Letters Patent No. 706,004, dated August 5, 1902.

Application filed August 2, 1901. Serial No. 70,607. (No model.)

To all whom it may concern:

Be it known that I, GUSTAF B. ANDERSON, a subject of the King of Sweden and Norway, residing at Chicago, in the county of Cook and State of Illinois, have invented certain new and useful Improvements in Pneumatic Motors, of which the following is a specification.

This invention relates to improvements in air or wind motors, and is more especially intended to be used for operating the music-sheets of self-playing musical instruments, but is applicable for other purposes; and it consists in certain peculiarities of the construction, novel arrangement, and operation of the various parts thereof, as will be hereinafter more fully set forth and specifically claimed.

The objects of my invention are to provide a motor of the above-described character which shall be simple and inexpensive in construction, strong, durable, and effective in operation, and which may be employed for driving a shaft in either direction.

In order to enable others skilled in the art to which my invention pertains to make and use the same, I will now proceed to describe it, referring to the accompanying drawings, in which—

Figure 1 is a view in side elevation of the motor embodying my invention, showing the parts in position ready for operation. Fig. 2 is a plan view thereof. Fig. 3 is a rear end view shortened for the convenience of illustration. Fig. 4 is a vertical sectional view taken on line 4 4 of Fig. 5. Fig. 5 is a view, partly in section and partly in elevation, taken on line 5 5 of Fig. 4. Fig. 6 is a vertical sectional view taken on line 6 6 of Fig. 7. Fig. 7 is a plan view, partly in section and partly in elevation, taken on line 7 7 of Fig. 6; and Fig. 8 is a fragmental plan sectional view taken on line 8 8 of Fig. 6 looking in the direction indicated by the arrows.

Similar letters refer to like parts throughout the different views of the drawings.

A represents the main frame or casing of the motor, which may be made of any suitable size, form, and material and is provided with a central opening a , flaring from its top and tapering toward its bottom. Within the opening a of the casing and secured trans-

versely to the walls thereof are located in pairs pieces A^1 and A^2 , each of which is formed with a channel a^1 , having near its upper end an internal opening a^2 and near its lower end an external opening a^3 for the purposes presently to be explained. The pieces A^1 and A^2 are united together in pairs at their edges and upper portions by means of membranes of leather or other suitable flexible material, thus forming two bellows B and B' or power-pneumatics, located side by side, as is clearly shown in Figs. 2 and 5 of the drawings. Within each of the bellows and secured at its edges to the middle portion of the membrane a thereof is a movable piece C, which rests at its lower end on the bottom of the opening a in the casing and has on its upper end a projection c , which contacts with suitable downwardly-extending projections c^1 on each of the valve-bars C^1 and C^2 , located transversely on the upper portion of the casing and secured at their ends to the valves C^3 and C^4 , located in pairs at the ends of the casing to close ports therein. Extending longitudinally with the casing and secured to its upper portion is a bar D, having a transverse shaft d at its middle, on each end of which is mounted a roller d^1 to contact with springs on the valve-bars C^1 and C^2 , and which springs and rollers are for the purpose of regulating the movements of the said valve-bars. Journalled on a suitable bracket D^1 , secured to the casing A, is a pulley or sheave D^2 , to which a belt may be applied for transmitting power from the motor to the part to be actuated or driven. The shaft d^2 of the pulley D^2 is provided at each of its ends with crank-wheels d^3 , to which are connected at one of their ends pitman-rods D^3 , which rods are pivotally connected at their other ends to the projections c on the upper ends of the movable pieces C in the bellows B and B', respectively.

The front end of the casing A is provided with upper and lower air-chambers E and E', respectively, which communicate with one another by means of channels e and which chambers communicate with the channels a^1 through the openings a^3 and channels e^1 , leading from said openings to the channels e . The rear portion of the casing is formed with an upper and lower air-chamber E² and E³, respectively, which communicate through chan-

nels e and e' with the passages a' adjacent thereto. The bottom of each of the air-chambers E' and E^3 are provided with a number of recesses e^2 , over which are secured diaphragms e^3 , which support the lower ends of the valve-stems e^4 , which stems pass through the channels e and carry valves F and F' to open and close the upper and lower ends, respectively, of said channels. The bottom of the casing A is provided with an opening G , which may be connected to the main bellows or wind-producing device of the instrument. Extending longitudinally through the bottom of the casing A is a channel G' , which communicates with the opening G and also communicates through ports g with the air-chambers E' and E^3 in the front and rear portions, respectively, of the casing. Leading from the channel G' to the recesses e^2 in the air-chambers E' and E^3 are passages g' , and also leading from said recesses are passages g^2 , which extend upwardly through the front and rear portions of the casing and have external openings or ports g^3 and g^4 , which are opened and closed by means of the hinged valves C^3 and C^4 , respectively. The central portion of the inner walls of the upper air-chambers E and E^2 have openings h , which are constantly open to the outer air, and which openings are located between the two bellows B' and B' .

From the foregoing and by reference to the drawings it will be seen and readily understood that by forcing air through the opening or passage G it will pass through the channel G' , port g , into the air-chamber E' , through the channels e , e' , and a' , into the front portion of the bellows B' , thus inflating said part of said bellows and deflating the rear portion thereof or causing the movable piece C to move toward the pulley D^2 , thus causing it through the pitman to rotate. The air from the deflated portion of the bellows B' will pass through the channels a' e' e into the upper air-chamber E^2 in the rear portion of the casing and exhaust through the opening h therein. While the above-named operation is taking place, the rear portions of the bellows B will be inflated, thus causing its movable piece C to move toward the front portion of the casing and through its connection with the pulley cause the same to further rotate. When the parts are in said positions, it is apparent that one of the ports g^3 at the rear end of the casing and one of the ports g^4 at the front of the casing will be opened, thus allowing the air to escape through the channels g^2 from the recesses e^2 and permitting the valve-stems to drop, so as to close the upper ends of one of the channels e at the front of the casing and one of said channels at the rear thereof. As the wheel or pulley D^2 continues to rotate, the movable pieces C in the bellows B and B' will move back and forth, thus causing the projections c thereon to impinge the projections c' on the valve-bars C' and C^2 , and thereby

open and close the ports g^3 and g^4 at the proper times. It is apparent that the motor will operate by blow-pressure or exhaust-pressure.

Having thus fully described my invention, what I claim as new, and desire to secure by Letters Patent, is—

1. The combination with a casing having a central opening and air passages and chambers communicating therewith, of valves to open and close said passages, two bellows located in said opening, means to inflate and deflate a portion of each of the bellows alternately, a power wheel or pulley journaled near the casing and means connecting the pulley and bellows whereby the pulley is rotated, substantially as described.

2. The combination with a casing having a central opening and air chambers and passages communicating therewith, of valves to open and close said passages, two bellows located in said opening, a movable piece in each of the bellows, means to inflate and deflate a portion of each of the bellows alternately, a power wheel or pulley journaled near the casing, pitman-rods connecting the movable pieces of the bellows and the power-wheel, substantially as described.

3. The combination with the casing having a central opening and air chambers and passages communicating therewith, of valves to open and close said passages, two bellows located in said opening, a movable piece in each of the bellows, means to inflate and deflate a portion of the bellows alternately, a power wheel or pulley journaled near the casing, pitman-rods connecting the movable pieces of the bellows and the power-wheel, a bar located above each of the bellows and connected at its ends to valves for closing the external openings of the casing, means on each of said bars to engage the upper portion of the movable pieces of the bellows, substantially as described.

4. The combination with a casing having a central opening and air passages and chambers communicating therewith, of valves to open and close said openings, two bellows located in said opening, a movable piece in each of the bellows and having on its upper end an outward extension, means to inflate and deflate the bellows alternately, a power wheel or pulley journaled near the casing, pitman-rods connecting the movable pieces of the bellows and the power-wheel, a bar extending over each of the bellows and having on its lower surface downward projections, valves at each end of each of said bars to close the external openings in the upper part of the casing, a pulley journaled above each of said bars, a spring on each of said bars and in contact with the pulleys, substantially as described.

GUSTAF B. ANDERSON.

Witnesses:

KNUTE A. RUETHIN,
CHAS. C. TILLMANN.