



INTERNATIONAL APPLICATION PUBLISHED UNDER THE PATENT COOPERATION TREATY (PCT)

(51) International Patent Classification ⁷ : A61F 2/06	A1	(11) International Publication Number: WO 00/57818 (43) International Publication Date: 5 October 2000 (05.10.00)
<p>(21) International Application Number: PCT/US00/08757</p> <p>(22) International Filing Date: 29 March 2000 (29.03.00)</p> <p>(30) Priority Data: 09/280,161 29 March 1999 (29.03.99) US</p> <p>(71) Applicant (for all designated States except US): CARDIO SYNOPSIS INC. [US/US]; Suite 4, 524 Weddell Avenue, Sunnyvale, CA 94086 (US).</p> <p>(71)(72) Applicants and Inventors: HNOJEWYJ, Olexander [-/US]; 13925 Trinity Avenue, Saratoga, CA 95070 (US). CRUISE, Gregory, M. [-/US]; 3444 Ellery Common, Fremont, CA 94538 (US). EDWARDS, Stuart, D. [-/US]; 658 Westridge Drive, Portola Valley, CA 94028 (US).</p> <p>(74) Agents: RYAN, Daniel, D. et al.; P.O. Box 26618, Milwaukee, WI 53226 (US).</p>	<p>(81) Designated States: AE, AL, AM, AT, AU, AZ, BA, BB, BG, BR, BY, CA, CH, CN, CR, CU, CZ, DE, DK, DM, EE, ES, FI, GB, GD, GE, GH, GM, HR, HU, ID, IL, IN, IS, JP, KE, KG, KP, KR, KZ, LC, LK, LR, LS, LT, LU, LV, MA, MD, MG, MK, MN, MW, MX, NO, NZ, PL, PT, RO, RU, SD, SE, SG, SI, SK, SL, TJ, TM, TR, TT, TZ, UA, UG, US, UZ, VN, YU, ZA, ZW, ARIPO patent (GH, GM, KE, LS, MW, SD, SL, SZ, TZ, UG, ZW), Eurasian patent (AM, AZ, BY, KG, KZ, MD, RU, TJ, TM), European patent (AT, BE, CH, CY, DE, DK, ES, FI, FR, GB, GR, IE, IT, LU, MC, NL, PT, SE), OAPI patent (BF, BJ, CF, CG, CI, CM, GA, GN, GW, ML, MR, NE, SN, TD, TG).</p> <p>Published <i>With international search report.</i></p>	
(54) Title: STENT WITH AN INTEGRATED FILM COATING FOR DEPLOYMENT THROUGHOUT THE BODY		
(57) Abstract		
<p>An expandable stent (10) for deployment in the body comprises a tubular body (12) having an interior (14), an exterior (16) and a lattice structure (17) with open interstices. The stent carries a bio-compatible coating (18), which is applied to the tubular body as a flowing polymer. The coating comprises a continuous film (20) that envelops the entire lattice structure, and spans the interstices of the lattice structure. The film extends continuously between the interior, and exterior of the stent, and is free of an interior boundary layer.</p>	<p>The diagram shows a perspective view of a cylindrical stent. It consists of a tubular body with a lattice structure. The interior of the tubular body is labeled 14, the exterior is labeled 16, and the lattice structure is labeled 17. The stent is shown in a slightly expanded state.</p>	

FOR THE PURPOSES OF INFORMATION ONLY

Codes used to identify States party to the PCT on the front pages of pamphlets publishing international applications under the PCT.

AL	Albania	ES	Spain	LS	Lesotho	SI	Slovenia
AM	Armenia	FI	Finland	LT	Lithuania	SK	Slovakia
AT	Austria	FR	France	LU	Luxembourg	SN	Senegal
AU	Australia	GA	Gabon	LV	Latvia	SZ	Swaziland
AZ	Azerbaijan	GB	United Kingdom	MC	Monaco	TD	Chad
BA	Bosnia and Herzegovina	GE	Georgia	MD	Republic of Moldova	TG	Togo
BB	Barbados	GH	Ghana	MG	Madagascar	TJ	Tajikistan
BE	Belgium	GN	Guinea	MK	The former Yugoslav Republic of Macedonia	TM	Turkmenistan
BF	Burkina Faso	GR	Greece			TR	Turkey
BG	Bulgaria	HU	Hungary	ML	Mali	TT	Trinidad and Tobago
BJ	Benin	IE	Ireland	MN	Mongolia	UA	Ukraine
BR	Brazil	IL	Israel	MR	Mauritania	UG	Uganda
BY	Belarus	IS	Iceland	MW	Malawi	US	United States of America
CA	Canada	IT	Italy	MX	Mexico	UZ	Uzbekistan
CF	Central African Republic	JP	Japan	NE	Niger	VN	Viet Nam
CG	Congo	KE	Kenya	NL	Netherlands	YU	Yugoslavia
CH	Switzerland	KG	Kyrgyzstan	NO	Norway	ZW	Zimbabwe
CI	Côte d'Ivoire	KP	Democratic People's Republic of Korea	NZ	New Zealand		
CM	Cameroon		Republic of Korea	PL	Poland		
CN	China	KR	Republic of Korea	PT	Portugal		
CU	Cuba	KZ	Kazakstan	RO	Romania		
CZ	Czech Republic	LC	Saint Lucia	RU	Russian Federation		
DE	Germany	LI	Liechtenstein	SD	Sudan		
DK	Denmark	LK	Sri Lanka	SE	Sweden		
EE	Estonia	LR	Liberia	SG	Singapore		

**STENT WITH AN INTEGRATED FILM COATING FOR
DEPLOYMENT THROUGHOUT THE BODY**

RELATED APPLICATION

5 This application is a continuation-in-part
of copending United States Patent Application Serial
No. 09/195,071, filed November 18, 1998, and
entitled "Segmented Polyurethane Coating for Stents
and Vascular Grafts."

10 **FIELD OF THE INVENTION**

The invention relates to coatings for
stents or grafts deployed in vessels or other lumens
in the body.

BACKGROUND OF THE INVENTION

15 Expandable stents are widely used
throughout the body, e.g., in the heart, in the
circulatory systems, in the gastro-intestinal tract,
or in the urological tract.

20 Stents are used to hold open a segment of
a blood vessel, an artery, or other body lumen. For
example, expandable stents are commonly used to
support and hold open a coronary artery after an
angioplasty procedure.

25 Generally speaking, expandable stents are
made from a metal alloy, e.g., stainless steel. The

- 2 -

stents have a hollow tubular shape with a coiled, wound, or braided outer wall presenting an open lattice configuration. The open lattice configuration imparts flexibility and the ability to expand *in situ* within a blood vessel or other body lumen.

For example, when used in the coronary artery, the outer wall is forced to expand *in situ* by an interior balloon into an enlarged shape. These stents are called balloon-expandable stents.

Or, when used in larger peripheral blood vessels, the outer wall is biased or coiled toward a normally expanded condition, which can be compressed within a catheter tube to a smaller diameter for introduction. These stents self expand into a larger diameter *in situ* within a blood vessel. These stents are called self-expanding stents.

Most commercially available stents possess an open mesh structure, which imparts flexibility and expansion capabilities. However, the open mesh structure provides pathways for intimal hyperplasia into the interior of the stent. Cellular ingrowth can, in time, contribute to a narrowing of the lumen diameter.

The use of polymeric or biologic materials to coat or cover a stent, and thereby impede the cellular ingrowth phenomenon, is known. However, the coefficient of expansion of the coating material is often not well matched to the coefficient of expansion of the stent itself. Upon expansion of the stent in the intended way, the coating material can tear, rendering the coating useless for its intended purpose. Applying a thicker coating to overcome tearing can itself deter the intended expansion

- 3 -

characteristics of the stent.

Therefore, there remains a need for materials and methods for coating a stent that prevents the infiltration or ingrowth of cells after implantation, yet does not impede the physical properties of the stent to flex or expand.

SUMMARY OF THE INVENTION

One aspect of the invention provides a coated expandable stent. The stent comprises a tubular body having a lattice structure with open interstices. The body includes an interior and an exterior. The stent includes a biocompatible coating, which is applied to the tubular body as a flowable polymer. The coating comprises a continuous film that envelops the entire lattice structure and spans the interstices of the lattice structure. The film extends continuously between the interior and exterior of the stent and is free of an interior boundary layer.

The continuous polymeric film blocks or impedes cellular ingrowth. The continuous polymeric film also possesses flexible and durable mechanical properties, which resist tearing or adhesion failure during normal flexure, expansion, or contraction of the enveloped tubular body. The continuous polymeric film comprises an integral skin, which continuously conforms to the shape of tubular body, without failure or rupture.

In one embodiment, the polymer of the coating comprises an elastomer material. In a preferred embodiment, the polymer of the coating comprises a polyurethane material, and, most preferably, a polyether urethane urea material.

In one embodiment, the coating carries a therapeutic agent.

- 4 -

In one embodiment, the tubular body carries a microporous material that carries a therapeutic agent.

5 Features and advantages of the inventions are set forth in the following Description and Drawings, as well as in the appended Claims.

BRIEF DESCRIPTION OF THE DRAWINGS

10 Fig. 1 is a perspective view of an expandable stent having a tubular body with open interstices;

Fig. 2 is a perspective view of the stent shown in Fig. 1 after application of a biocompatible coating in accordance with the invention, which was applied to the tubular body as a flowable polymer;

15 Fig. 3 is an enlarged view of the coating applied to the stent shown in Fig. 2, showing the coating comprising a continuous film that envelops the entire lattice structure and spans the interstices of the lattice structure, extending continuously between the interior and exterior of the stent and being free of an interior boundary layer;

20 Fig. 4 is a side view of a mandrel usable to form the coating on the stent shown in Fig. 2, the mandrel being shown as a three part assembly in a disassembled condition;

Fig. 5 is a side view of the mandrel shown in Fig. 4 in a fully assembled condition;

30 Fig. 6 is a side view of the mandrel shown in Fig. 4, partially assembled and receiving a stent for coating;

Fig. 7 is a side view of the mandrel shown in Fig. 4, fully assembled and holding a stent for coating;

35 Fig. 8 is an elevation view of the fully

- 5 -

assembled mandrel shown in Fig. 7, being dipped into a solution of polymer material to apply the material to the stent;

5 Fig. 9 is an elevation view of the fully assembled mandrel shown in Fig. 7, placed in an oven for curing;

Fig. 10 is a side view of the mandrel shown in Fig. 7, disassembled to allow soaking of the coating to swell the polymer;

10 Fig. 11 is a side view of the mandrel shown in Fig. 7 during the removal of the stent after the polymer has been swelled;

Fig. 12 is a side view of another seamless mandrel usable to form the coating on the stent shown in Fig. 2;

Fig. 13 is a perspective view of the stent shown in Fig. 2 after the incorporation of a drug or therapeutic agent in the biocompatible coating; and

20 Fig. 14 is a perspective view of the stent shown in Fig. 2 with a microporous material having a drug or therapeutic agent wrapped about the biocompatible coating.

The invention may be embodied in several forms without departing from its spirit or essential characteristics. The scope of the invention is defined in the appended claims, rather than in the specific description preceding them. All embodiments that fall within the meaning and range of equivalency of the claims are therefore intended to be embraced by the claims.

DETAILED DESCRIPTION OF THE PREFERRED EMBODIMENTS

I. Coated Stents

35 Fig. 2 shows an expandable stent 10 that embodies features of the invention. The stent 10 may be either temporarily or permanently deployed in a

- 6 -

body lumen, such as a coronary artery, carotid artery, vessels in the brain, aorta, peripheral arteries and veins, and the like. The stent 10 can also be deployed in the urethra, esophagus, and other lumens throughout the body. The stent 10 is used primarily to support the interior of the body lumen so that it remains patent and permits the uninterrupted flow of blood or other fluids through it.

10 **A. Stent Body**

The stent 10 includes a tubular body 12 (see Fig. 1). The tubular body 12 is made, e.g., from plastic or metal or metal alloys such as stainless steel, tantalum, nickel-titanium, platinum/iridium, and a cobalt alloy. The stent 10 includes an interior 14 and an exterior 16.

By design, the tubular body 12 possesses an open lattice structure 17 of interwoven or braided wires, or struts, or coils. The tubular body 12 is made this way by known etching processes or by laser cutting a metal tube, or by winding or weaving or braiding metal wires. The open lattice structure imparts to the body 12 flexibility and the ability to expand from a small diameter and an enlarged diameter.

The tubular body 12 can be expanded *in situ* in various ways. The body 12 can, e.g., be normally contacted and mounted in conventional fashion in a normally contracted state about a balloon dilation catheter. Expansion of the balloon expands the tubular body 12 for use within a lumen. These stents, called balloon-expandable stents, are commercially available from, e.g., Guidant Corporation (Santa Clara, California); Palmaz-Schatz (Johnson and Johnson), and Gianturco (Cook

- 7 -

Incorporated). Typically, these stents present a constricted diameter of about 2 mm and an enlarged diameter of about 5 mm.

5 Alternatively, the tubular body 12 can be
braded or coiled to normally possess an expanded
condition. These stents are forced to a contracted
state within a catheter tube for introduction. When
released from the catheter tube, the stents self
expand within the vessel or lumen. These stents,
10 called self-expanding stents, are available from,
e.g., Schneider (sold under the trade name
WALLSTENT™), InStent (sold under the trade name
CARDIOCOIL™), and Cordis Corporation (sold under the
trade name SmartStent™). Typically, these stents
15 present a constricted diameter of about 2 mm and an
enlarged diameter of about 8 mm.

B. The Stent Coating

Fig. 2 shows the stent 10 shown in Fig. 1
after having been encapsulated within an inert,
20 biocompatible coating 18 in accordance with the
invention. The coating 18 comprises a film 20 (see
Fig. 3) that is applied to the tubular body 12 as a
flowable polymer, as will be described in greater
detail later. The polymer undergoes a phase change
25 to form the film 20.

As Fig. 3 shows, the film 20 envelops the
entire lattice structure 17, spanning the
interstices of the lattice structure 17. The film 20
extends continuously between the interior 14 and
30 exterior 16 of the stent 10 and is free of an
interior boundary layer.

The tubular body 12 and continuous,
boundary-free film 20 form an integrated structure
along both interior 14 and exterior 16. The film 20
35 possesses superior mechanical properties. During

- 8 -

normal flexure, expansion, or contraction of the underlying tubular body 12, the film 20 continuously conforms to the shape of tubular body 12, without rupture and without adhesion failure.

5 Encapsulated in the film 20, the tubular body 12 takes on enhanced physical properties in terms of its biocompatibility, flexure, and durability. The film 20 provides a uninterrupted, integral skin, which encapsulates the tubular body 10 12 within an inert, biocompatible envelope. The film 20 shields the tubular body 12 from contact with body fluids or tissue. Physiologic reactions or degradation or corrosion of the tubular body 12 that can result from direct contact between the material 15 of the tubular body 12 and tissue or body fluids are avoided. The film 20 also serves to block or impede ingress of cells, restenosis, or the progression of an occlusive disease through the exterior 16 and into the interior 14 of the tubular body 12.

20 In a preferred embodiment, the coating 18 comprises a segmented polyurethane polymer material having a theoretical (i.e., calculated) molecular weight of about 70,000 g/mole to about 85,000 g/mole. The polymer material possesses a linear 25 structure imparting flexibility and durability. As will be described in greater detail later, the polymer material of the coating 18 is applied to the body 12 as a solution, e.g., by dipping or spraying.

30 The material of the coating 18 is most preferably formed from an aromatic polyether urethane urea, with a soft segment of polytetramethylene ether glycol (PTMEG) and a hard segment of diphenylmethane diisocyanate (MDI) and mixed diamines. The material preferably possesses a 35 theoretical molecular weight between about 65,000

- 9 -

g/mole and about 100,000 g/mole, more preferably between 65,000 and 85,000 g/mole, and most preferably between 70,000 g/mole and 80,000 g/mole.

5 The material of the coating 18 also includes a stabilizing additive package consisting of an antioxidant and a surface modifying agent.

The material of the coating 18 has been demonstrated to be biocompatible and non-toxic in a variety of physiological applications.

10 In the preferred embodiment, the coating material is made in solution form in a three step reaction process. First, PTMEG and MDI are reacted under controlled conditions within a reactor to form an isocyanate prepolymer. The isocyanate prepolymer is
15 next reacted with an amine package, which includes at least one agent to expand the prepolymer chain and at least one agent to stop the expansion of the prepolymer chain when a desired theoretical molecular weight is approached. A stabilizer
20 package is then added to the expanded polymer chain.

Solvent is added at each step of the process to maintain a desired viscosity to aid mixing and processing.

25 The result is a solution, which can be applied by dip coating, or roller coating, or spray coating to the stent, and which, when heat cured, forms the coating 18 having the desirable properties mentioned.

(i) The Prepolymer

30 In the preferred embodiment, the prepolymer material includes between about 83 to 85 about percent (by solids weight) of a polytetramethylene ether glycol material (PTMEG) having a theoretical molecular weight of between about 1950 and 2050.
35 The PTMEG is generally expressed as compounds of the

formula:

5

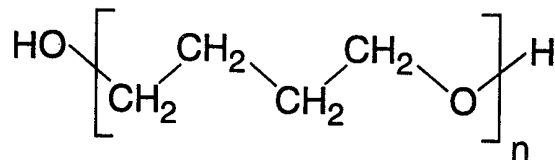

10

The prepolymer also includes from about 14 to about 17 percent (by solids weight) of a 4,4'-Methylene bis(phenyl isocyanate) material (MDI). MDI is generally expressed as compounds of the formula:

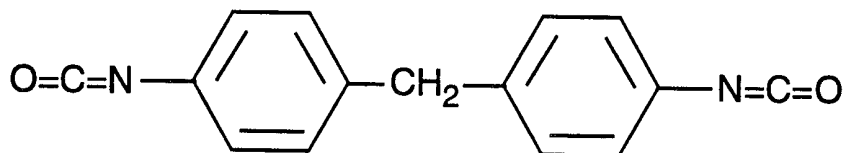

15

The reaction of PTMEG and MDI is achieved by mixing in a heated reaction chamber, e.g., in a five gallon reactor, such as PflaudlerJ, Pflaudler RXJ, BNKOJ, or equivalent.

20

The mixing of PTMEG and MDI occurs in the presence of a solvent N,N-dimethylacetamide (DMAC), which is added to achieve a desired solids weight percent to prevent gelation and aid processing. Preferably a solids weight percent of between 15% and 30%, and most preferably 20%, is achieved by addition of DMAC. The solvent DMAC is generally expressed as compounds of the formula:

25

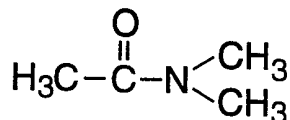

30

The mixing yields a solution comprising a linear, isocyanate-terminated prepolymer. The

resulting linear, isocyanate-terminated prepolymer solution possesses an active N=C=O group at opposite ends of the polymer. The reaction and resulting polymer can be expressed as compounds of the formula:

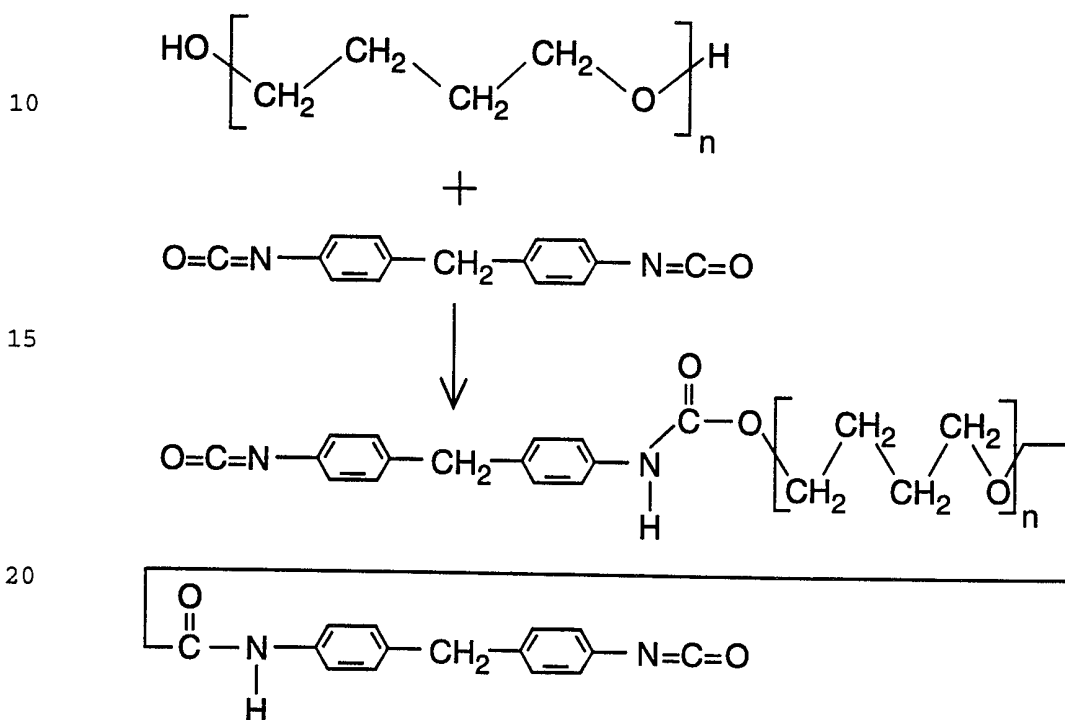

25

In the preferred embodiment, by total weight (solids and solvent) percent, the linear, isocyanate-terminated prepolymer solution preferably contains about 17% PTMEG, about 3% MDI, and about 80% DMAC.

30 **(ii) Chain Expansion**

The isocyanate-terminated prepolymer in the solution is next expanded by reaction with an amine package.

35 In the preferred embodiment, the amine package includes difunctional chain extenders, to cause

expansion of the prepolymer chain. In the preferred embodiment, the amine package also includes a chain stopper, to prevent the chain expansion beyond a desired magnitude, which would interfere with the physical properties desired for the coating.

In particular, the magnitude of expansion is selected to yield a desired theoretical molecular weight for the coating material, at which the desired durability and flexibility characteristics are achieved. The magnitude of expansion is empirically determined, based upon the polymer materials used and other processing variables. In the preferred embodiment, the magnitude of expansion is about fifteen fold.

In the illustrated embodiment, the amine package includes ethylene diamine (ETD) having a theoretical molecular weight of about 60. ETD is a difunctional chain extender, which can be generally expressed as compounds of the formula:

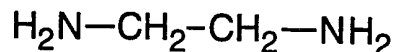

The amine package also includes 1,3 diaminocyclohexane (DCH) having a theoretical molecular weight of about 114. DCH is also a difunctional chain extender, which can be expressed as compounds of the formula:

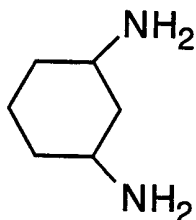

The amine package further includes diethylamine (DEA) having a theoretical molecular weight of about 73. DEA is a chain stopper, which

can be expressed as compounds of the formula:



5 The amine package is mixed with the linear, isocyanate-terminated prepolymer solution under heat in the reactor. Solvent DMAC is also added to maintain desired processing viscosity.

10 In a preferred embodiment, a fifteen fold chain extension of the prepolymer is targeted. With this magnitude of chain extension, the chain extension mixture (by solids weight percent) is prepolymer (98.1%); ETD (.57%); DCH (1.1%); and DEA (0.2%). For each 2000 grams of prepolymer mixed with the amine package, about 600 grams of DMAC is added during mixing.

15 The mixing yields a solution of linear polyether urethane urea polymer, with center polyurethane chains and urea groups at opposite ends. This reaction and the resulting polymer can be generally expressed as compounds of the formula:

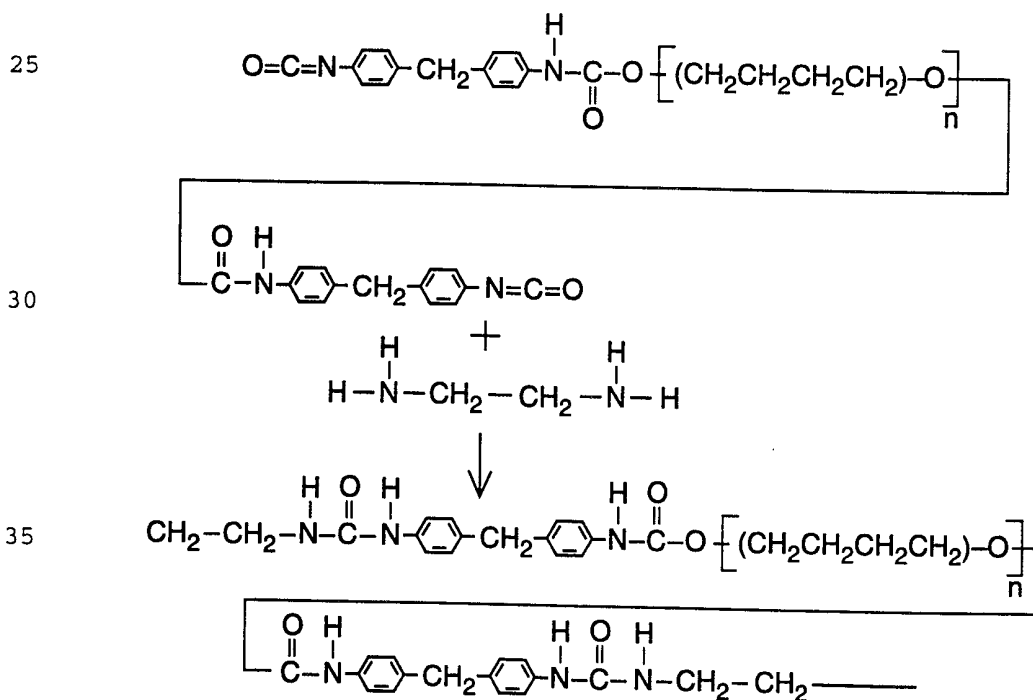

(iii) Stabilization

The coating material includes a stabilizer package.

In the preferred embodiment, the stabilizer package includes an antioxidant 4, 4'-butylidene bis (6-tert-butyl-m-cresol), which can be expressed as compounds of the formula:

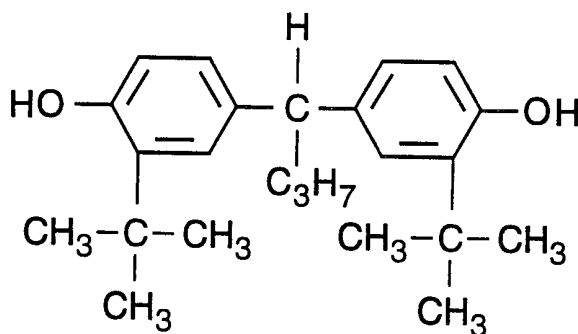

In the preferred embodiment, the stabilizer package also includes a surface modifying (acrylic resin dispersion used as antisnag and bodying agents) additive co-diisopropylamino-ethylmethacrylate/decyl methacrylate, which can be expressed as compounds of the formula:

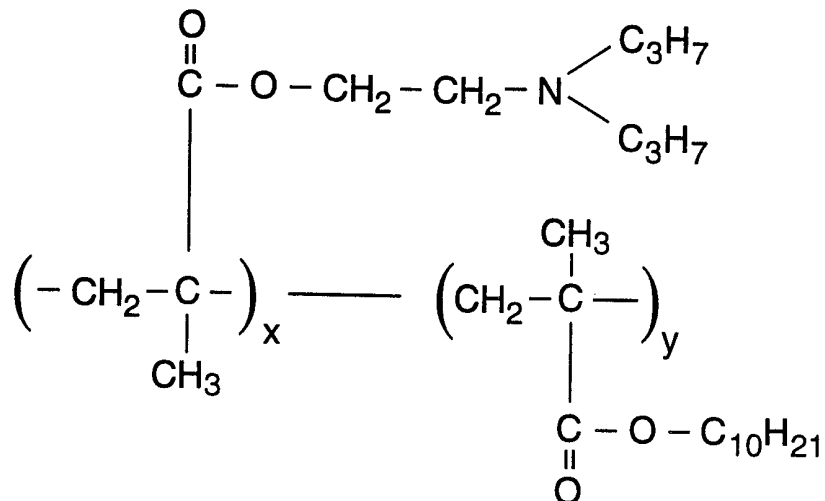

- 15 -

The stabilizer package is mixed with the extended prepolymer-amine solution under heat in the reactor. Solvent DMAC is also added to maintain desired processing viscosity.

5 In the preferred embodiment, the coating material includes about 1% by solids weight of 4, 4'-butylidene bis (6-tert-butyl-m-cresol) and about 5% by solids weight of co-diisopropylamino-ethylmethacrylate/decyl methacrylate. In the preferred
10 embodiment, about 60 grams of DMAC is added for every 2042 grams of total solids.

The following presents an illustrative example of the details of the making of the preferred coating material.

15

Example 1

Making the Polymer Material

The following describes the steps of making a solution of the polymer material, in accordance with the invention, for use as a coating for a stent, using
20 a five gallon reactor vessel.

I. Preparation of the Prepolymer

1. Select to react three moles of MDI (250 g/mole theoretical molecular weight) with two moles of PTMEG (2000 g/mole theoretical molecular weight), to
25 maintain a desired theoretical molecular weight of 4750 for the resulting prepolymer.

2. Based upon the selected moles, calculate the weight amount of MDI and PTMEG
30 required for the prepolymer, as follows:

Material	Moles	g/mole	g	% wt
PTMEG	2	2000	4000	84.21
MDI	3	250	750	15.79

Total			4750	100.00
--------------	--	--	------	--------

- 5 3. Reduce the prepolymer to 20% solids by weight by use of 80% by weight solvent DMAC.

Material	% wt	% Solids	% By Weight
PTMEG	84.2	20	16.84
MDI	15.8	20	3.16
DMAC		80	80
Total			100

- 10 4. Calculate the weight amounts of PTMEG, MDI, and DMAC to be added, taking into account the capacity of the five gallon reactor (10,000 grams), based upon the % by weight calculated in step 3. This yields 2000 grams of the prepolymer in 8000 grams of DMAC, as follows:

Material	Grams
PTMEG	1684
MDI	316
DMAC	8000
Total	10,000

- 25 5. Preheat 1684 grams of PTMEG to 50°C outside the reactor in an oven to get the polymer flowable.
6. Transfer the heated PTMEG into the reactor, and heat to 60°C while mixing at 25 RPM (for good mixing).
- 30 7. Preheat 316 grams of MDI to 50°C outside the reactor in an oven to get the polymer flowable.

- 17 -

- 5
8. Add the heated MDI through a drip funnel to the reactor containing the PTMEG while stirring at 35 RPM (for good vortex mixing, without splashing), for a period of 30 minutes.
9. Increase the temperature to the reaction temperature of 80°C for a period of two hours.
- 10
10. Reduce temperature to 60°C.
11. Add 8000 grams of the solvent DMAC through a drip funnel over a period of ten minutes.
12. Mix for thirty additional minutes, at a temperature of 50°C.
- 15
- II. Preparation of Amine Package (Chain Extending Step)**
1. Select the magnitude of extension of the prepolymer. In this example, based upon empirical data, a 15-fold increase is selected.
- 20
2. Based upon the selected magnitude of extension, calculate the units of prepolymer and amine package. The following model graphically expresses the methodology of this calculation:
- 25

Z-□-X-□-Y-□-X-□-Y-□-X-□-Y-□-X-□-Y-□-X-□-Y-□-X-□-Y-□-X-□-Y-□-X-□-Y-□-Z

where:

- 30
- is composed of 3 moles of MDI and 2 moles of PTMEG = 15 units.
- X is DCH = 7 units.
- Y is ETD = 7 units.
- Z is DEA = 2 units.
- 35
3. Convert to the units of preceding Step

2 to grams for the 2000 gram batch of the prepolymer (from Step 4 of the preceding Preparation of the Prepolymer).

5

Material	Units	Molecular Weight	Molecular Weight Units	Wt %	Batch Grams
Prepolymer	15	4750	71,250	98.1	2000 gr
DCH	7	114.19	799.33	1.10	22.45 gr
ETD	7	60	420	0.57	11.62 gr
DEA	2	73.14	146.28	0.2	4.01 gr

10

Empirical experience indicates that under the processing conditions of the Example, the calculated 4.01 batch grams for the DEA chain stopper is not sufficient to stop the chain expansion at 15 fold. Based upon this empirical experience, the batch amount of DEA is doubled to 8.02 grams to provide a processing margin of error.

15

20

4. To the amine package, 600 grams of solvent DMAC is added to obtain a solids percent weight less than about 30%, to maintain a desired mixing viscosity.

25

5. The amine package added to the 2000 grams of prepolymer is therefore composed of the following:

DCH: 22.45 gr

ETD: 11.62 gr

DEA: 8.02 gr

30

Solvent (DMAC): 600 gr

6. The amine package is added by drip funnel at 60°C over a period of 15

- 19 -

minutes.

5. The prepolymer-amine mixture is stirred at 30 RPM's for 30 minutes at 60°C.
6. The temperature is lowered to 50°C, the speed of mixing is reduced to 20 RPM's, and mixing under these conditions proceeds for an additional 30 minutes.

III. Stabilization

1. Based upon empirical experience, 1% by solids weight of 4, 4'-butylidene bis (6-tert-butyl-m-cresol) (20.42 grams) (in shorthand BB) and about 5% by solids weight of co-diisopropylaminoethyl methacrylate / decyl methacrylate (102.10) (in shorthand DM) is added in 60 grams of DMAC over a period of 15 minutes to the expanded polymer mixture (which constitutes 2042 grams of total solids).
2. Mixing is continued for 2 hours at 50°C at a speed of 25 RPM's.
3. The stabilized polymer material solution is discharged through a filter from the reactor and stored in an inert nitrogen atmosphere.

IV. Final Composition Summary

1. Prepolymer Package

PTMEG:	1684 gr
MDI:	<u>316 gr</u>
Total Solids	2000 gr
DMAC (Solvent)	8000 gr

2. Amine Package

DCH:	22.45 gr
ETD:	11.62 gr

- 20 -

DEA: 8.02 gr
 Total 42.09 gr
 DMAC (Solvent) 600 gr

5 3. Stabilizer Package
 BB 20.42 gr
 DM 102.10 gr
 Total Solids 122.52 gr
 DMAC (Solvent) 60 gr

10 3. Finished polyether urethane urea
 solution
 Total solids 2164.61 gr
 Total composition 10,824.61 gr
 15 Percent Solids 20%

C. Application of the Stent Coating

The polyether urethane urea material of the coating prepared according to the preceding Example (in shorthand called PEUU) can be applied while in a flowable solution state to a balloon-expandable stent or a self-expanding stent, to form the continuous film 20.

A seamless mandrel 22 (see Figs. 4 and 5) holds the stent while the material is applied. The mandrel 22 is made, e.g., from stainless steel. The mandrel 22 can be variously constructed.

In the embodiment shown in Figs. 4 and 5, the mandrel 22 comprises three separable pieces; namely, a front piece 24, a handle piece 26, and an intermediate stent mount 28.

The front piece 24 includes an enlarged grip having a diameter D2 greater than the diameter D1 of the stent mount 28. The front piece 24 includes a tapered neck 30. The front piece 24 progressively diminishes in diameter along the neck 30 from the grip

- 21 -

diameter D2 to a stem 32. The stem 32 extends a short distance beyond the tapered neck 30. The stem 32 has a diameter equal to the mount diameter D1. A circumferential groove 34 is formed on the tapered neck 30 in advance of the stem 32.

A centered, stepped bore 36 passes through the front piece 24 to accommodate insertion of a shoulder bolt 38. The externally threaded end 40 of the shoulder bolt 38 extends beyond the stem 32 to engage an internally threaded, centered, stepped bore 42 in the stent mount 28. The shoulder bolt 38 threads into the bore 42 to connect the front piece 24 to the stent mount 28.

A witness line 44 marks the abutment of the stem 32 and an end of the stent mount 28. Due to the stem 32, the witness line 44 is spaced inward of the tapered neck 30 and groove 34. The witness line 44 is machined smooth, to present a seamless junction.

The handle piece 26 is longer than the front piece 24, to provide more gripping area for manipulating the mandrel 22 during use. The handle piece 26 includes an enlarged grip having a diameter D3 greater than the diameter D1 of the stent mount 28. The handle piece 26 also includes a tapered neck 46, along which the handle piece 26 progressively diminishes in diameter from the grip diameter D2 to a stem 48. The stem 48 also extends a short distance beyond the tapered neck 46. The stem 48 has a diameter equal to the mount diameter D1. Another circumferential groove 50 is formed on the tapered neck 46 in advance of the stem 48.

A centered, stepped bore 52 passes through the handle piece 26 to accommodate insertion of a second shoulder bolt 54. The externally threaded end 56 of the second shoulder bolt 54 extends beyond the stem 48

- 22 -

to engage the internally threaded, centered stepped bore 58 in the stent mount 28. The shoulder bolt 54 threads into the bore 58 to connects the handle piece 26 to the stent mount 28.

5 A second witness line 60 marks the abutment of the stem 48 and the stent mount 28. Like the first witness line 44, the second witness line is spaced inward of the tapered neck 46 and groove 50. The witness line 44 is likewise machined smooth, to
10 present another seamless junction.

In use (see Fig. 6), the technician connects the handle piece 26 to the stent mount 28. Holding the handle piece 26, the technician slides the stent S to be coated onto the stent mount 28.

15 The technician slides a balloon-expandable stent onto the mount 28 in its normal constricted condition. The technician slides a self-expanding stent on to the mount 28 in its fully expanded condition.

20 The difference in diameter between D1 and the interior diameter of the stent S, when placed on the mount 28, defines the thickness of the film 20 along the interior of the stent S. It should be appreciated that the exterior surface of the mount 28 can be
25 uniform or tapered or flouted to create non iso-radial or otherwise nonuniform regions. The mount 28 could also be curved along its length to impart a bias.

In a preferred embodiment, the diameter D1 of the mount 28 exceeds the interior diameter of the
30 stent S, when mounted for coating, by about 0.314 inches \pm 0.001 inches. This diameter difference provides a sufficient film thickness, while preventing "floating" of the stent S on the stent mount 28. Given this diameter difference, the stent stays in position
35 and does not shift side-to-side along the stent mount

- 23 -

28 during coating.

With the stent S positioned on the mount 28, the technician secures the front piece 24 to the mount 28 (see Fig. 7). The length of the mount 28 is selected to allow the ends of the stent S to extend a distance beyond the stems 32 and 48 and onto the tapered necks 30 and 46, but short of the grooves 34 and 50. The front piece 24 and the handle 26 hold the stent S in slight compression on the stent mount 28, to assure that the interstices are held open during the coating process.

The mandrel 22 and stent S are dipped into a bath 62 containing a flowable solution 64 of PEUU (see Fig. 8). The bath 62 preferably includes a recirculation loop 66, to maintain mixing within the bath 62. The recirculation loop 66 also preferably includes an in line filter 68 to remove congealed particles from the PEUU solution. The recirculation loop 66 also preferably includes a viscosity sensor 70, to assure that solvent loss during processing does not lower the viscosity below a desired level.

After dipping, the mandrel 22 and stent S are removed from the bath 62. The excess PEUU solution 64 is allowed to drain off the stent S. The mandrel 22 may be held by the handle piece 26 and rotated about its axis to aid in the drainage of PEUU solution 64.

A phase change is induced in the flowable polymer solution 64 by placing the stent S and mandrel 22 in an oven 72 (see Fig. 9). The heat in the oven 72 flashes the remaining solvent, forming the solid film 20. A through hole 74 in the handle piece 26 accommodates a hanger 76, so that the mandrel 22 can be suspended in a vertical position inside the oven 72. It should be appreciated that the mount 28 itself can be internally heated to flash the solvent.

- 24 -

After heat curing, the film 20 formed beyond the ends of the stent S are scored, using grooves 34 and 50 to guide the cutting. The edges of the film 20 are teased back to break surface contact about the stems 32 and 48. The shoulder bolts 38 and 54 are screwed loose, and the handle piece 26 and front pieces 24 are removed.

The coated stent S, still carried by the mount 28, is placed in a dish of polymer swelling agent 106, e.g., isopropyl alcohol (10%) (see Fig. 10). The agent 106 causes the film 20 to swell sufficient to slide the coated stent S from the mount 28 (see Fig. 11).

A typical stent has a wall thickness of about 0.081 inches. A representative thickness for the coating is about 0.001 inches.

In an alternative embodiment (see Fig. 12), the seamless mandrel 22 comprises a two piece assembly, comprising a handle end 78 and the front end 80. The handle end 78 includes a neck 82 which tapers to an elongated stem 84 having a stepped threaded end 86. Similarly, the front end 80 includes a neck 88 which tapers to an elongated stem 90 having an interior threaded bore 92. The end 86 threads into the bore 92 to join the handle end 78 and front end 80. The witness line 94 is machined smooth to create a seamless junction. Together, the elongated stems 84 and 90 form a stent mount 96. Score grooves 98 and 100 are formed in the tapered necks 82 and 88, respectively.

In use, the stent S is placed on the handle piece 78, and the front piece 80 is threaded to the handle piece 78 to form the mandrel 22. The coating process proceeds in the manner previously described

The process using a seamless mandrel 22

- 25 -

applies a biocompatible coating as a flowable polymer to the tubular body of the stent. Once applied, the flowable polymer undergoes a phase change to form a solid film that envelops the interior and exterior surfaces and occludes the interstices of the tubular body. The film is continuous and free of boundary between the interior and exterior. The continuous coating affects recoil either stent by no more than 5%.

A stent coated according to the invention can be used deployed throughout the body, e.g., in the nervous system, in the heart, in the circulatory systems, in the gastro-intestinal tract, or in the urological tract.

D. Drug Delivery

The presence of the film 20 on the stent 10 also allows for the retention of a drug 102 and the dispensement of the drug 102 by the polymer of the film 20 (see Fig. 13). Alternatively, or in combination, a microporous material 104 carrying the same or a different drug 102 can be further applied over the film 20 (see Fig. 14).

For example, an anticoagulant such as heparin or the like can be bound to the polymer and dispensed from the film 20 and/or the microporous material 104 in a time-released fashion after deployment, e.g., to reduce thrombosis. Alternatively, other drugs, such as anti-inflammatory agents, steroids, antimitotic drugs like chemo- or radio-therapeutic drugs, or vascular endothelial growth factor (VEGF) or fibroblast growth factor (FGF) or other angiogenesis agents (promoting blood vessel growth) can be bound to the polymer of the film 20 and/or the microporous material 104 for release after deployment. Genetically engineered drugs or growth factors can also be bound to the polymer

- 26 -

film 20 and /or the microporous material 104 for *in situ* dispensement.

5 A stent coated according to the invention can be used as a drug delivery mechanism throughout the body, e.g., in the nervous system, in the heart, in the circulatory systems, in the gastro-intestinal tract, or in the urological tract.

10 As a specific example, the coated stents can incorporate angiogenesis agents, available, e.g., VEGF from Genetech or FGF from Chiron. The coated stents can be deployed in one or more coronary arteries. The coated stents release the angiogenesis agents over time. The angiogenesis agents promote the growth of new capillaries in the heart. The new capillaries
15 restore the link between the arteries and veins residing in previously blood starved regions of heart muscle, thereby obviating the need for tradition bypass surgery or angioplasty.

The features of the invention are set forth in the following claims.

We Claim:

1. An expandable stent for deployment in the body comprising
a tubular body having an interior and an exterior and a lattice structure with open
5 interstices, and
a biocompatible coating, which is applied to the tubular body as a flowable polymer, the coating comprising a continuous film that envelops the entire
10 lattice structure and spans the interstices of the lattice structure, the film extending continuously between the interior and exterior of the stent and being free of an interior boundary layer.
2. An expandable stent according to claim 1 wherein the polymer comprises an elastomer material.
- 15 3. An expandable stent according to claim 1 wherein the polymer comprises a polyurethane material.
4. An expandable stent according to claim 1 wherein the polymer comprises a polyether urethane urea material.
5. An expandable stent according to claim 1 wherein the coating is applied in solution by dipping the stent carried by a mandrel in the solution.
6. An expandable stent according to claim 1 wherein the coating carries a therapeutic agent.
7. An expandable stent according to claim 1 wherein the tubular body carries a microporous material.
8. An expandable stent according to claim 7 wherein the microporous material carries a therapeutic agent.

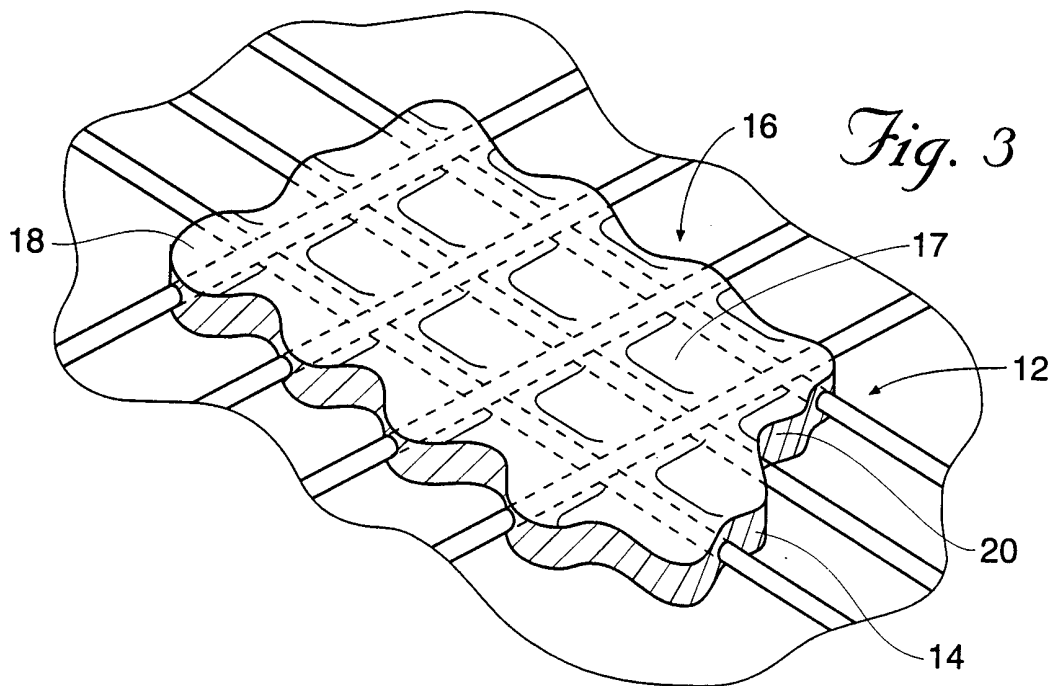
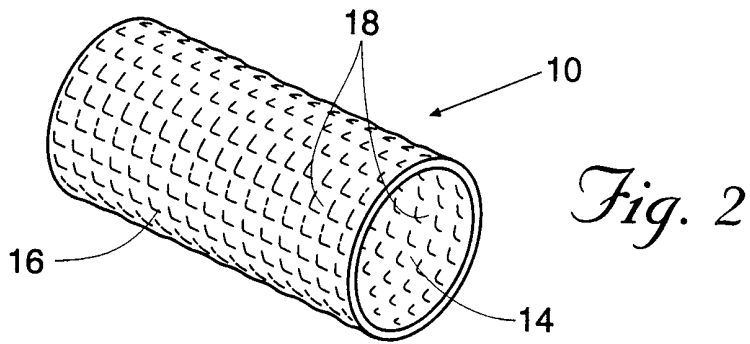
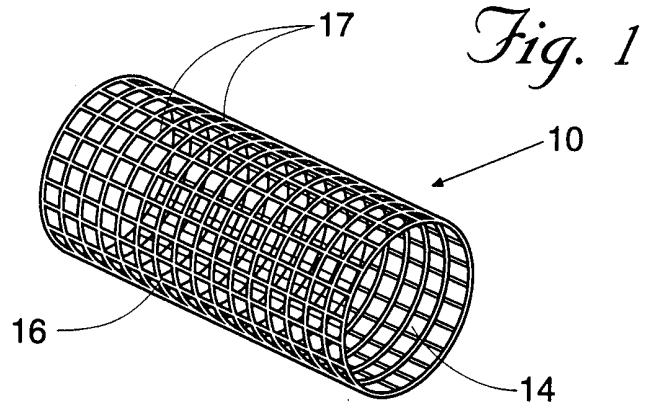

Fig. 4

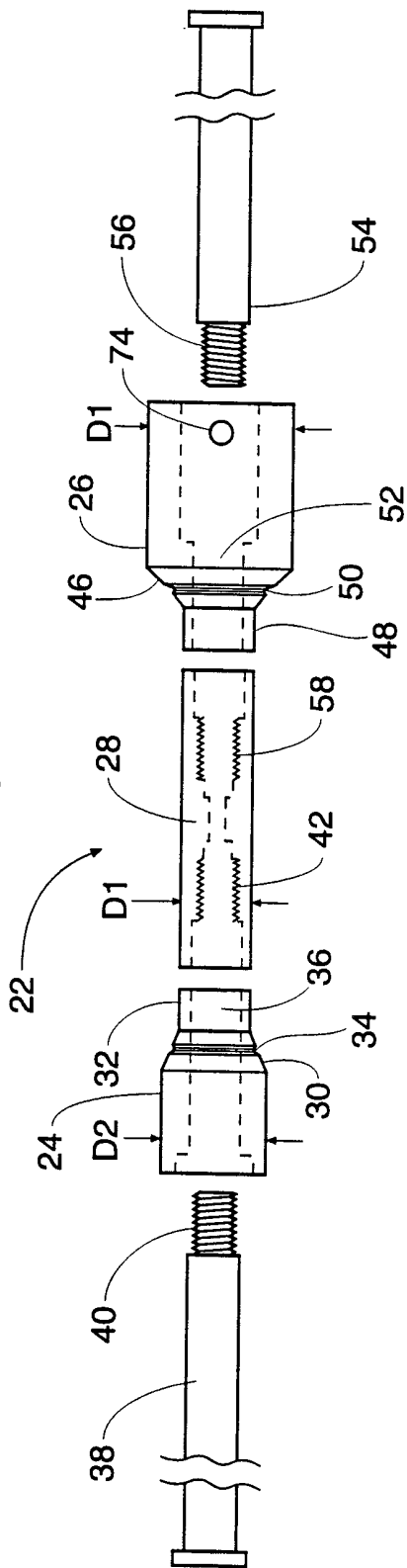
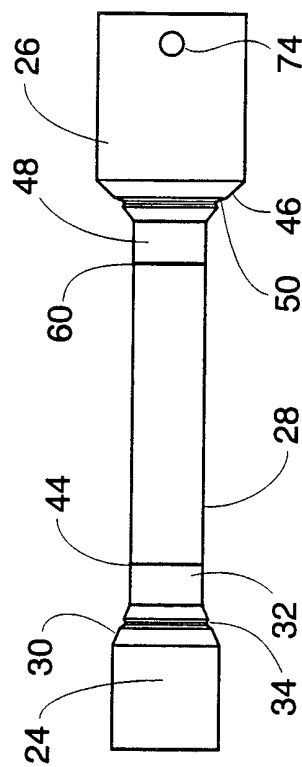

Fig. 5



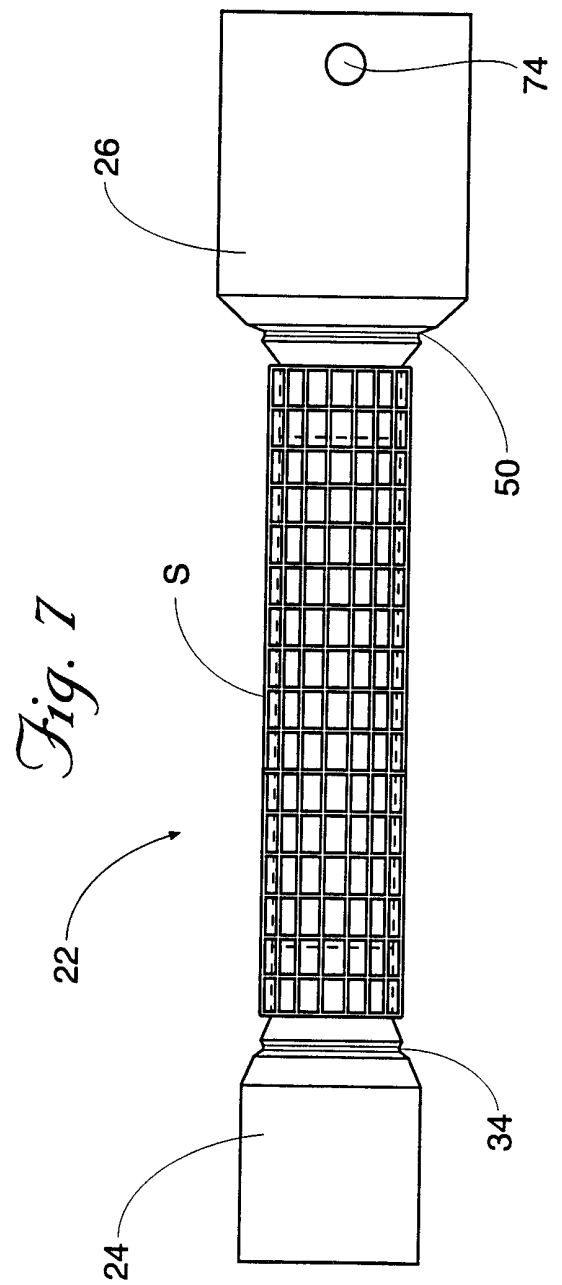
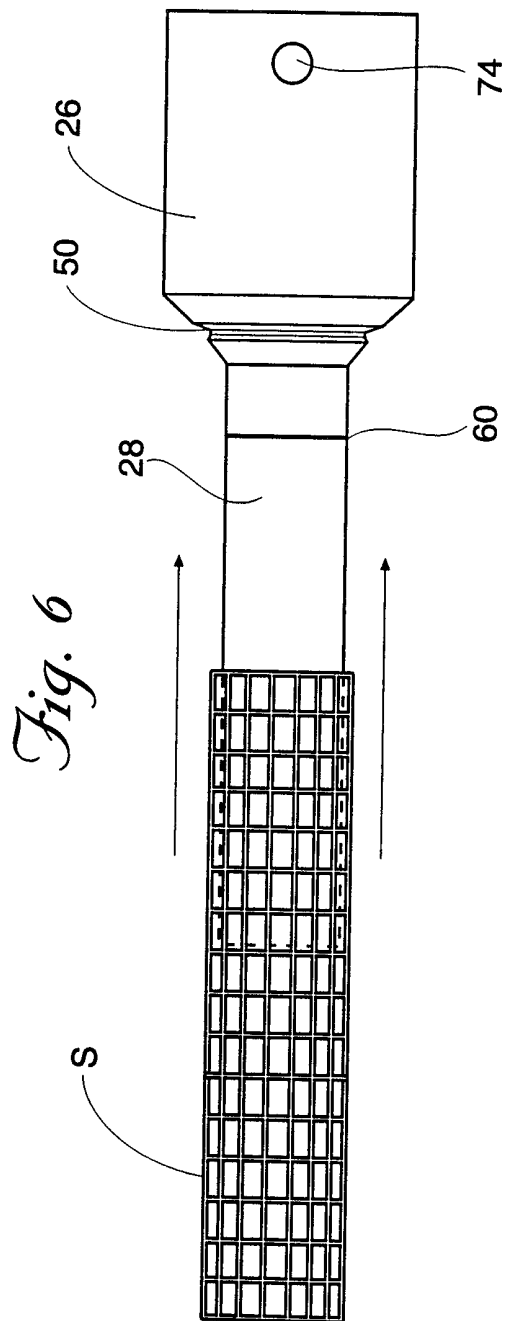

Fig. 8

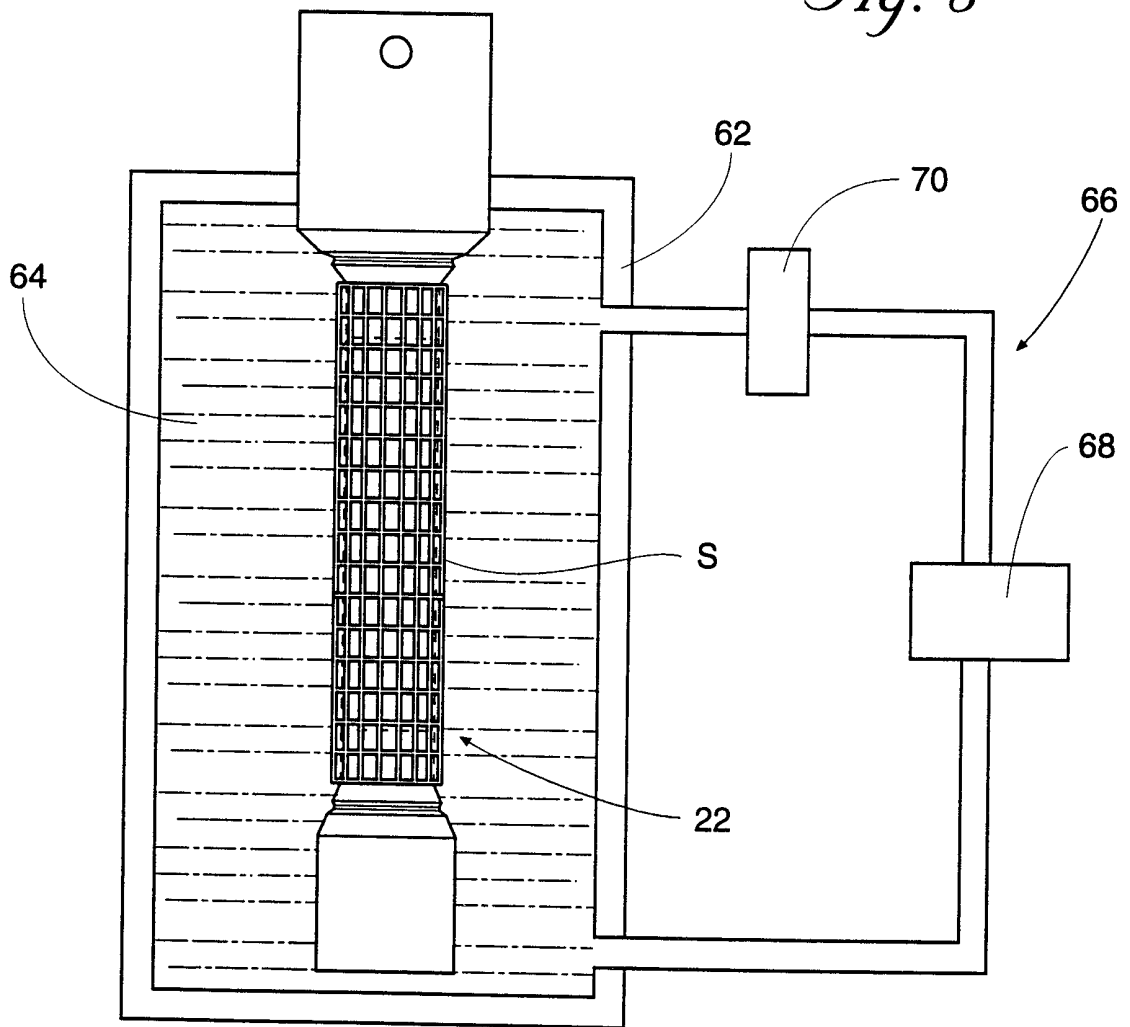

Fig. 9

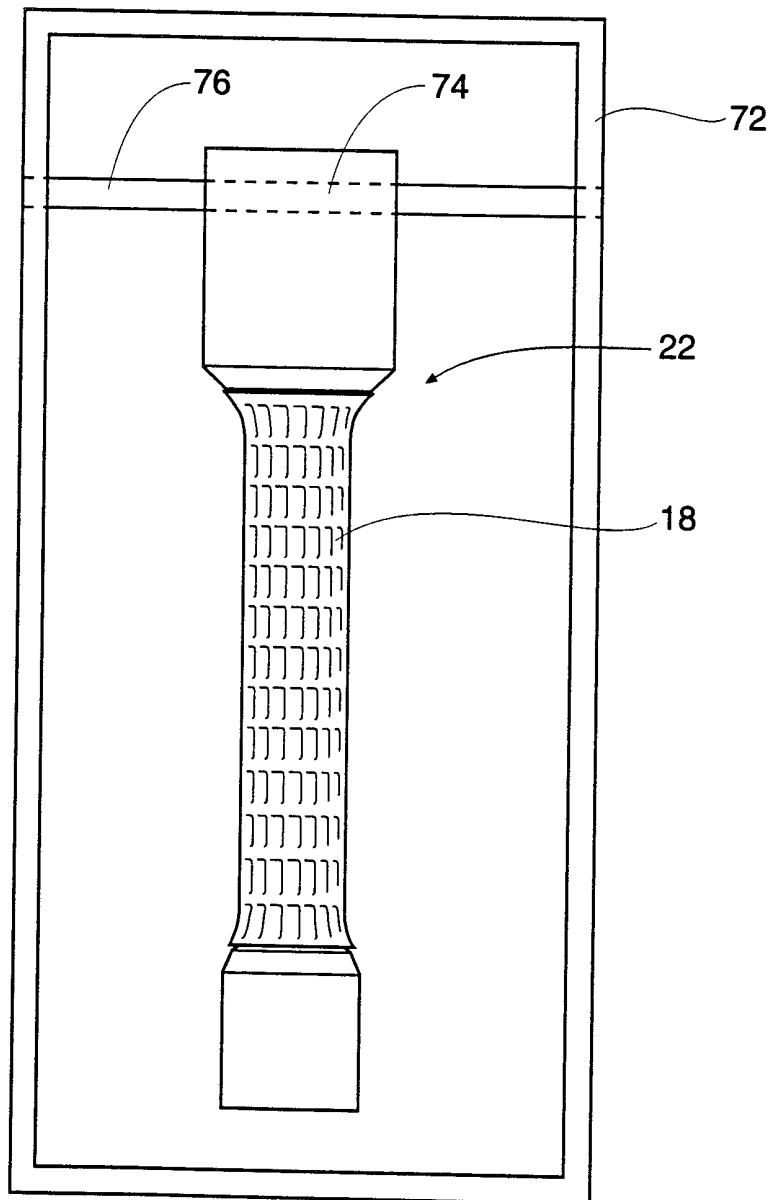

Fig. 1

Fig. 10

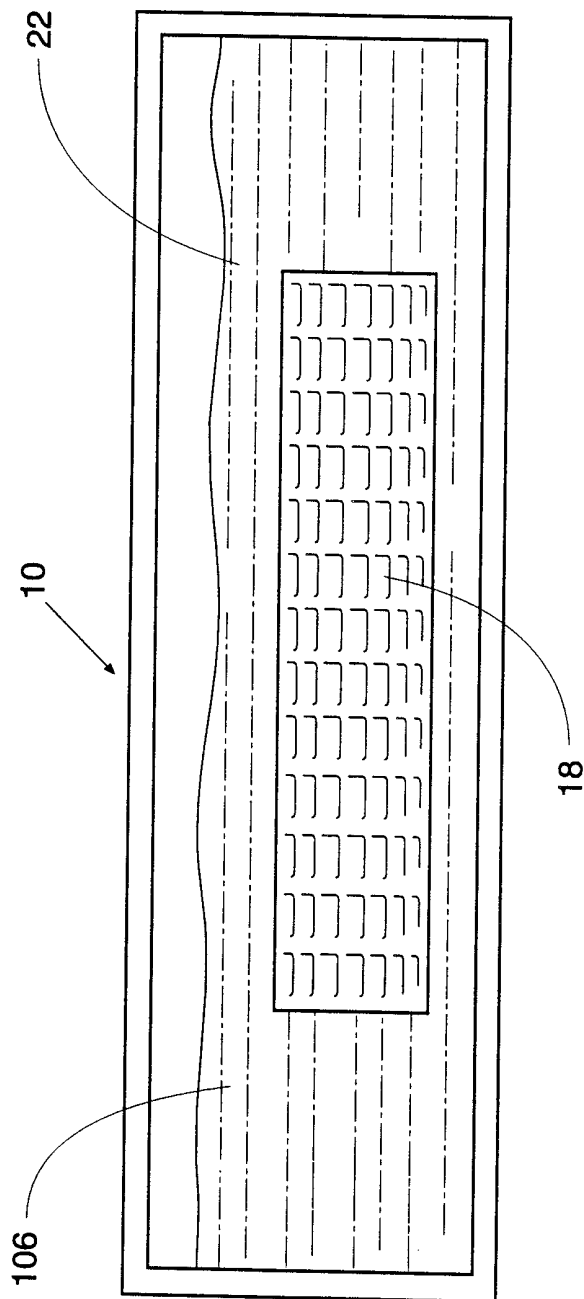
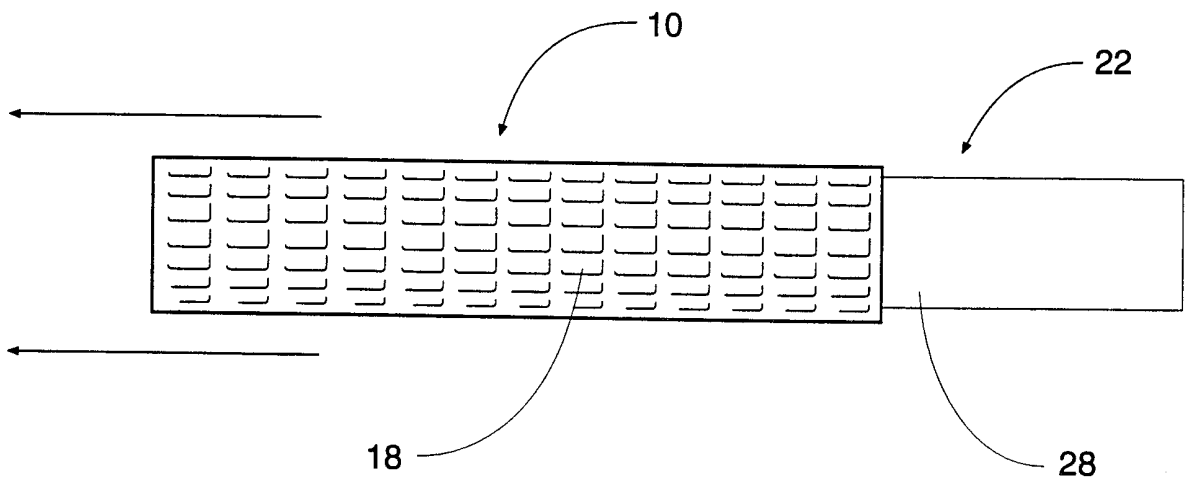
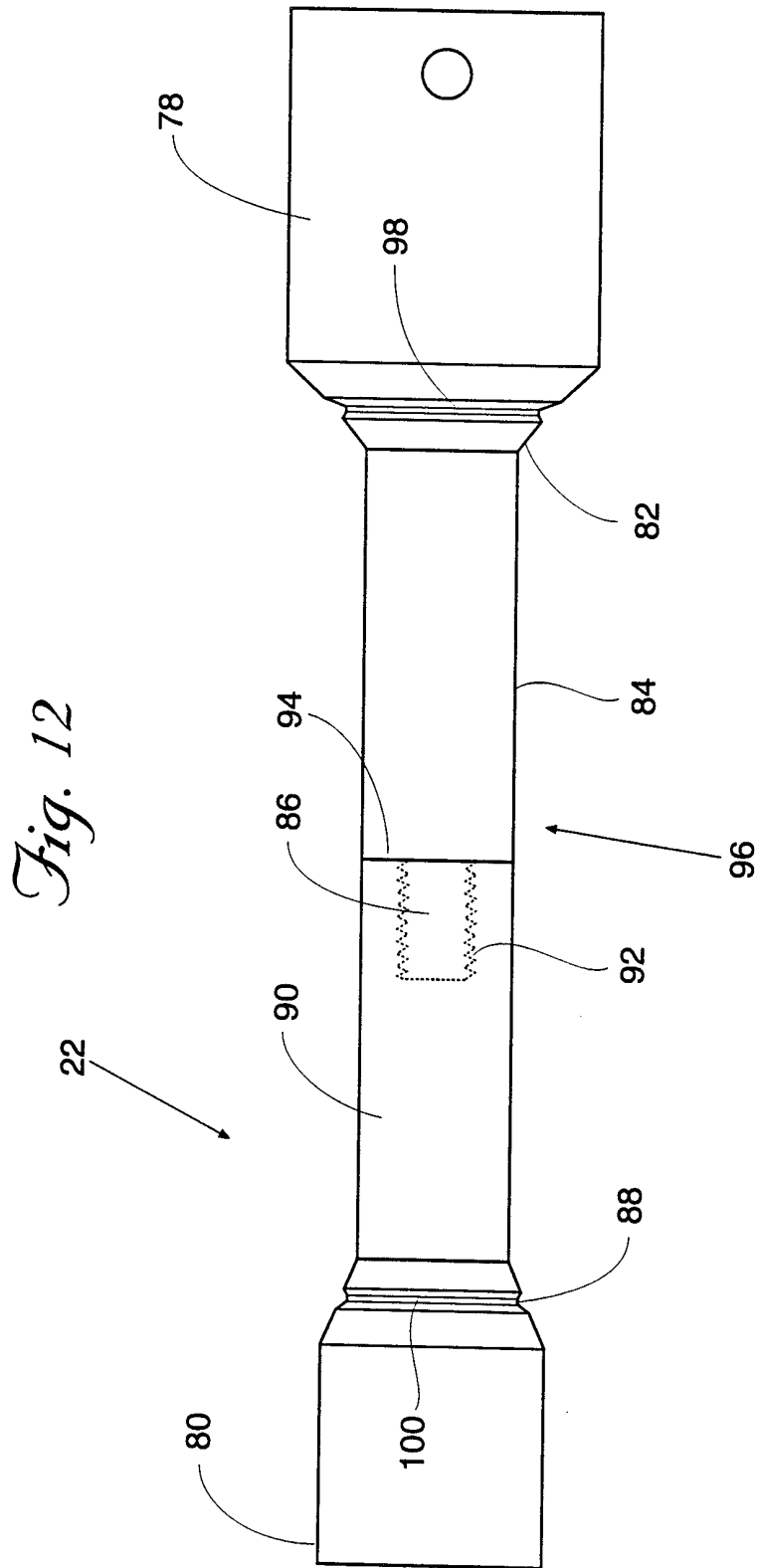

Fig. 11





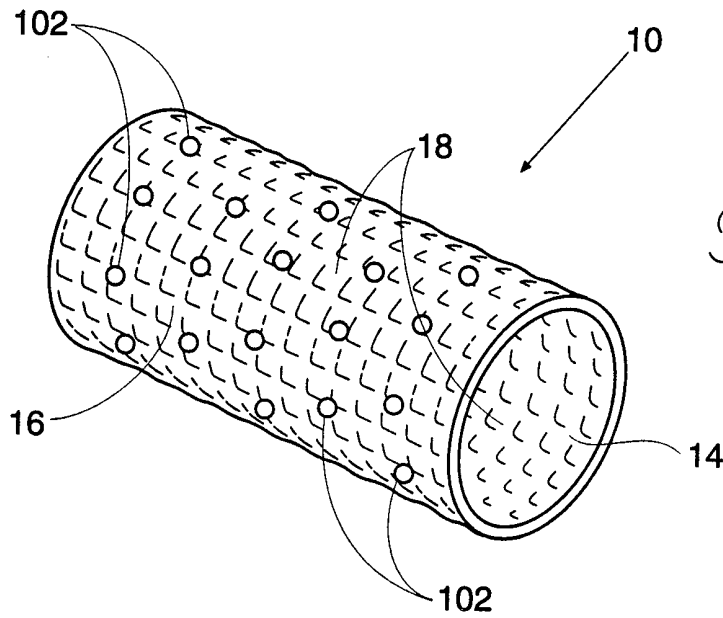

Fig. 13

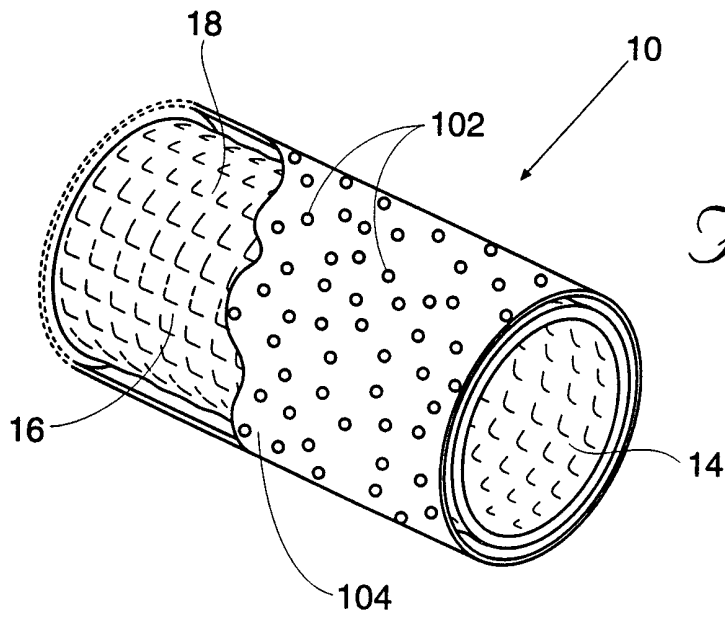

Fig. 14

INTERNATIONAL SEARCH REPORT

International application No.
PCT/US00/08757

A. CLASSIFICATION OF SUBJECT MATTER
 IPC(7) :A61F 2/06
 US CL :623/1.42
 According to International Patent Classification (IPC) or to both national classification and IPC

B. FIELDS SEARCHED
 Minimum documentation searched (classification system followed by classification symbols)
 U.S. : 128/343, 344; 600/36; 623/1, 1.42

Documentation searched other than minimum documentation to the extent that such documents are included in the fields searched

Electronic data base consulted during the international search (name of data base and, where practicable, search terms used)
 EAST

C. DOCUMENTS CONSIDERED TO BE RELEVANT

Category*	Citation of document, with indication, where appropriate, of the relevant passages	Relevant to claim No.
A	US 4,776,337 A (PALMAZ) 11 October 1988.	1-8

Further documents are listed in the continuation of Box C. See patent family annex.

* Special categories of cited documents:	"T" later document published after the international filing date or priority date and not in conflict with the application but cited to understand the principle or theory underlying the invention
"A" document defining the general state of the art which is not considered to be of particular relevance	"X" document of particular relevance; the claimed invention cannot be considered novel or cannot be considered to involve an inventive step when the document is taken alone
"E" earlier document published on or after the international filing date	"Y" document of particular relevance; the claimed invention cannot be considered to involve an inventive step when the document is combined with one or more other such documents, such combination being obvious to a person skilled in the art
"L" document which may throw doubts on priority claim(s) or which is cited to establish the publication date of another citation or other special reason (as specified)	"&" document member of the same patent family
"O" document referring to an oral disclosure, use, exhibition or other means	
"P" document published prior to the international filing date but later than the priority date claimed	

Date of the actual completion of the international search 23 MAY 2000	Date of mailing of the international search report 15 JUN 2000
--	--

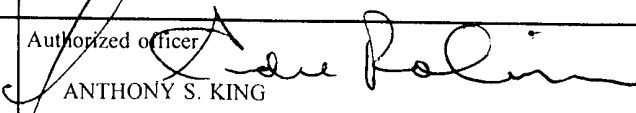
Name and mailing address of the ISA/US Commissioner of Patents and Trademarks Box PCT Washington, D.C. 20231 Facsimile No. (703) 305-3230	Authorized officer  ANTHONY S. KING Telephone No. (703) 306-5962
---	---