

Nov. 5, 1963

R. REINARTZ

3,109,644

CHAIN STACKER GRIPPER CONTROL

Filed June 12, 1961

2 Sheets-Sheet 1

Fig. 1.

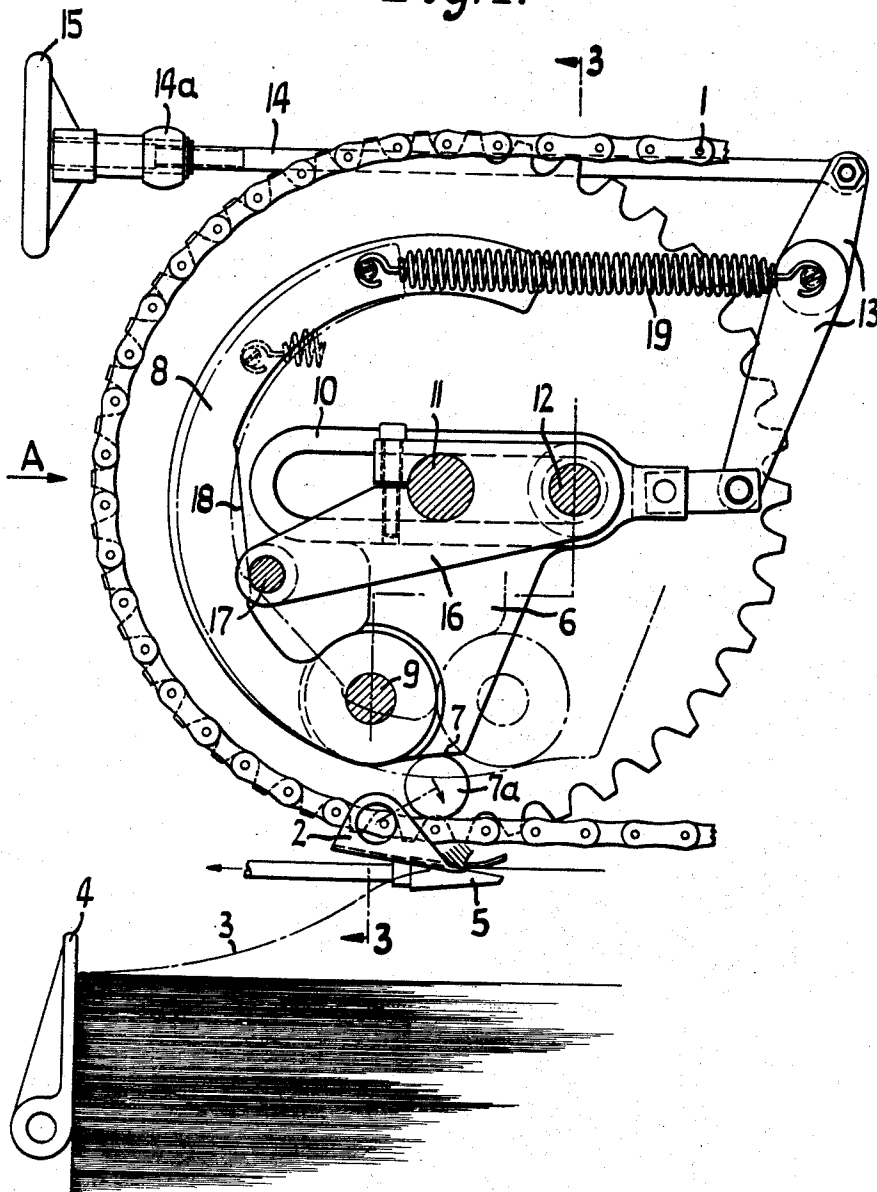

INVENTOR:

Robert Reinartz

By

Bailey, Stephens & Huetig
ATTORNEYS

Nov. 5, 1963

R. REINARTZ

3,109,644

CHAIN STACKER GRIPPER CONTROL

Filed June 12, 1961

2 Sheets-Sheet 2

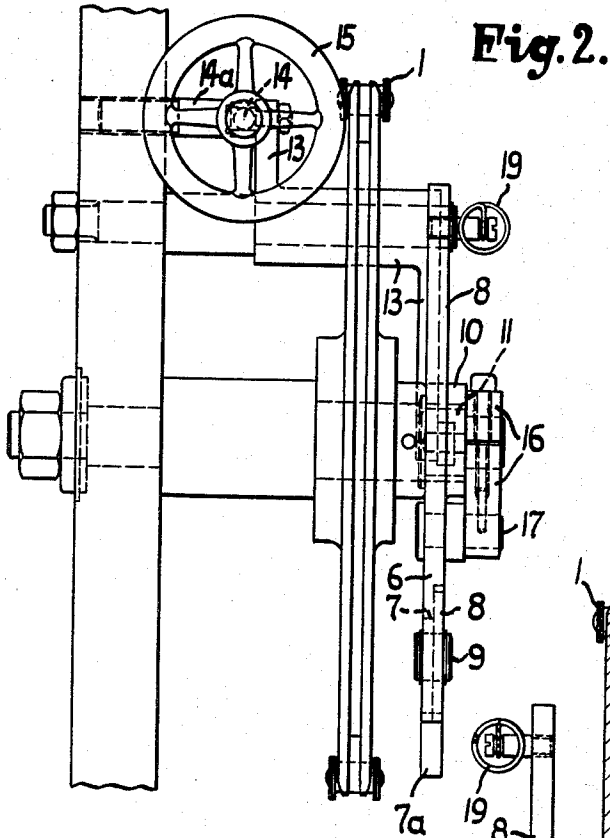

Fig. 2.

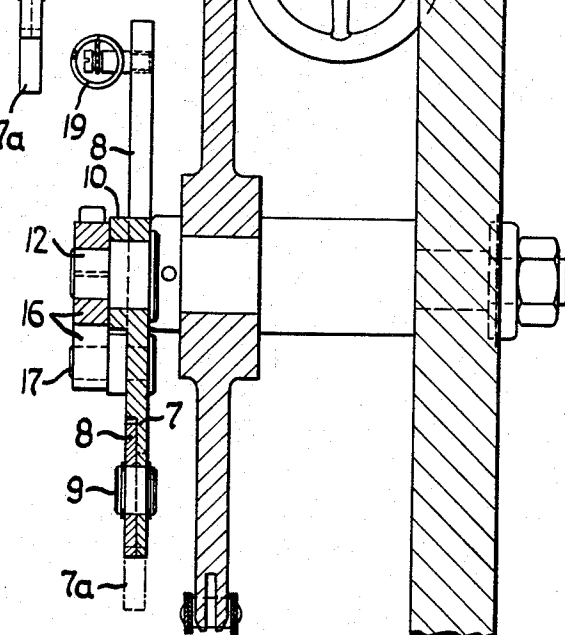

Fig. 3.

INVENTOR:
Robert Reinartz

by
Bailey, Stephens + Huettig
ATTORNEYS

1

3,109,644

CHAIN STACKER GRIPPER CONTROL

Robert Reinartz, Augsburg, Germany, assignor to Maschinenfabrik Augsburg-Nurnberg A.G., Augsburg, Germany

Filed June 12, 1961, Ser. No. 116,386

Claims priority, application Germany July 22, 1960

1 Claim. (Cl. 271-68)

This invention relates to a chain stacker for a printing press and, in particular, is directed to a gripper chain stacker.

More particularly, the invention is directed to means for controlling the grippers in chain stackers which have horizontally movable opening cams and which work in cooperation with a so-called following or after-gripper.

In numerous conventional stackers, the control cams are so arranged that the gripper travelling with the gripper chain opens before the sheet is dropped onto the stack and passes the sheet to a pneumatic after-gripper which, in turn, takes the sheet and brings it with a lessened velocity to the stacking plate of the stacking table. However, the suction of the after-gripper is not enough to grasp and hold a sheet of heavy paper or cardboard. Consequently, it has been the practice to remove and not use the after-grippers when handling heavy sheets or cardboard. The result has been that the heavy sheets or cardboard strike the stacking plate without being reduced in velocity and thereby damage the front edge of the sheet and produces a sloppy stack.

Attempts have been made to remedy this difficulty by moving the opening cam surface for the gripper around the axis of the chain sprocket. This has not produced a sufficient delay in the time of the opening of the gripper unless the knocking of the gripper roller against the cam surface is accepted.

It has also been the practice in the stacking of sheets in a printing press to displace the cam opening surface of the gripper in a horizontal direction. Such cam surfaces are positioned adjacent the horizontal reach of the stacker chains and used in machines in combination with after-grippers where great emphasis is placed on compact construction. This arrangement is not serviceable because it is necessary that the two gripper systems operate together.

The above disadvantages in the control of the grippers in a chain stacker for a printing press and in which the grippers operate in conjunction with after grippers are avoided by this invention in that the horizontally movable opening cam is flexibly connected to the curved cam arm which remains substantially in the line of its curve while being displaced as the gripper opening cam is moved with respect to a fixed point. By this construction, the delay of the opening of the gripper is given a greater range of time despite the fact that the after-gripper is not in use and without running the risk that the grippers will be closed prematurely and again grasp the sheet. This invention also permits a compact construction in that the outer chain sprocket can be mounted over the stack; while at the same time, a violent impact of the heavy sheets against the stacking plate is prevented.

The means by which the objects of the invention are obtained are described more fully with reference to the accompanying drawings, in which:

FIGURE 1 is a front elevational view of the invention; FIGURE 2 is a side view of FIGURE 1 taken in the direction of the arrow A; and

2

FIGURE 3 is a cross-sectional view taken on the line 3-3 of FIGURE 1.

As shown in the drawings, the gripper chain 1 carries sheet grippers 2 which grasp the sheets 3. The leading edge of the sheets 3 strike the stacking plate 4 as they are deposited upon the stack. During normal use of the machine, when handling lightweight sheets, the after-gripper 5 takes each sheet as it is released by the grippers 2 and moves the sheet with reduced velocity toward stacking plate 4. In normal light sheet operation, the opening cam 6 has the position as shown in full lines in FIGURE 1. The cam surface 7 bears upon the cam follower 7a to open grippers 2 at this position.

When heavy paper or cardboard is being handled, the construction is modified by extending the cam surface 7 by means of a curved cam arm 8 which is pivotally joined to cam 6 by pin 9.

Cam 6 is joined to a guide 10 in the form of an elongated slot which is slidably and turnably mounted on the axle 11 of the chain sprocket and a fixed stationary bearing 12. Guide 10 is movable by a lever 13 connected at one end to guide 10 and at the other end to shaft 14 which is displaceable by a gearing 14a actuated by hand-wheel 15. By pulling on shaft 14, the guide 10 and cam surface 7 are displaceable substantially parallel to the surface of the stack of sheets to a position indicated by the dash-dot line.

A stationary bracket 16 is clamped to axle 11 and bearing 12 for holding in a fixed position a stationary member 17 which bears against the flat surface 18 of the curved cam extension arm 8. The free end of arm 8 is connected to lever 13 by a spring 19.

In operation, when the opening cam surface 7 is displaced from the full line position shown to the dash-dot line position, the surface 18 slides along the stationary member 17 and is held thereagainst by means of spring 19 so that the curved extension arm 8 remains substantially in the line of its curve as shown by the dash-dot line. As the extension arm has not had its cam surface displaced essentially from its original position, the closing of gripper 2 does not occur until the gripper has passed beyond the leading edge of the sheet whereby the gripper cannot grasp the sheet again once it has been released. Although the invention has been described for a single gripper with its opening cam and after-gripper, it is to be understood that a plurality of grippers are arranged across the entire breadth of the machine.

Having now described the means by which the objects of the invention are obtained, I claim:

In a chain stacker for a printing press, said stacker having a horizontally displaceable opening cam for sheet grippers operating in conjunction with after-grippers, the improvement comprising a curved cam extension arm pivotally joined to said opening cam and having a surface forming a continuation of the surface of said opening cam, a stationary member bearing against said arm, and means for moving said opening cam into different positions while keeping said arm substantially in the line of its curve and bearing against said stationary member to change the opening point of the sheet gripper while maintaining an unchanged closing point for said sheet gripper.

References Cited in the file of this patent

UNITED STATES PATENTS

730,857	Annand	June 16, 1903
2,813,483	Keil	Nov. 19, 1957
2,969,980	Claybourn	Jan. 31, 1961