

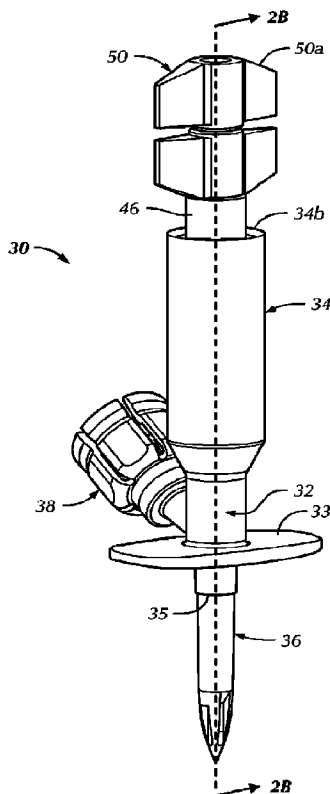

(86) Date de dépôt PCT/PCT Filing Date: 2020/01/13
 (87) Date publication PCT/PCT Publication Date: 2020/11/05
 (45) Date de délivrance/Issue Date: 2024/01/02
 (85) Entrée phase nationale/National Entry: 2021/10/26
 (86) N° demande PCT/PCT Application No.: IL 2020/050048
 (87) N° publication PCT/PCT Publication No.: 2020/222220
 (30) Priorité/Priority: 2019/04/30 (US62/840,620)

(51) Cl.Int./Int.Cl. *A61J 1/20* (2006.01),
A61M 5/162 (2006.01)
 (72) Inventeurs/Inventors:
BAR-EL, YOSSI, IL;
FABRIKANT, ELISHEVA, IL;
BEN SHALOM, NIV, IL
 (73) Propriétaire/Owner:
WEST PHARMA. SERVICES IL, LTD., IL
 (74) Agent: ROBIC

(54) Titre : DISPOSITIF DE TRANSFERT DE LIQUIDE AVEC POINTE IV A DOUBLE LUMIERE
 (54) Title: LIQUID TRANSFER DEVICE WITH DUAL LUMEN IV SPIKE



(57) **Abrégé/Abstract:**

A liquid transfer device includes a monolithic trifurcated connector body defining a barrel at a first end thereof, a single IV spike at a second end thereof and a vial adapter lumen at a third end thereof. An IV port is connected to the barrel. The single IV spike has a first IV spike lumen fluidly connected at a proximal end thereof with only the vial adapter lumen via the trifurcated connector body and a second IV spike lumen fluidly connected at a proximal end thereof with only the IV port via the trifurcated connector body, thereby separating fluid communication between the vial adapter and the single IV spike from fluid communication between the IV port and the single IV spike.

Date de soumission / Date Submitted: 2021/10/26

No de la demande can. / CA App. No.: 3135248

Abrégé:

Un dispositif de transfert de liquide comprend un corps de connecteur trifurqué définissant un cylindre à une première extrémité de celui-ci, une pointe IV unique à une seconde extrémité de celui-ci et une lumière d'adaptateur de flacon à une troisième extrémité de celui-ci. Un orifice IV est relié au corps. La pointe IV unique a une première lumière de pointe IV reliée de manière fluïdique à une extrémité proximale de celle-ci avec uniquement la lumière d'adaptateur de flacon par l'intermédiaire du corps de connecteur trifurqué et une seconde lumière de pointe IV reliée de manière fluïdique à une extrémité proximale de celle-ci avec uniquement l'orifice IV par l'intermédiaire du corps de connecteur trifurqué, séparant ainsi la communication fluïdique entre l'adaptateur de flacon et la pointe IV unique d'une communication fluïdique entre l'orifice IV et la pointe IV unique.

Abstract:

A liquid transfer device includes a monolithic trifurcated connector body defining a barrel at a first end thereof, a single IV spike at a second end thereof and a vial adapter lumen at a third end thereof. An IV port is connected to the barrel. The single IV spike has a first IV spike lumen fluidly connected at a proximal end thereof with only the vial adapter lumen via the trifurcated connector body and a second IV spike lumen fluidly connected at a proximal end thereof with only the IV port via the trifurcated connector body, thereby separating fluid communication between the vial adapter and the single IV spike from fluid communication between the IV port and the single IV spike.

LIQUID TRANSFER DEVICE WITH DUAL LUMEN IV SPIKE

CROSS-REFERENCE TO RELATED APPLICATIONS

[0001] Deleted.

BACKGROUND OF THE DISCLOSURE

[0002] The present disclosure is generally directed to liquid transfer devices.

[0003] Conventional infusion liquid containers containing an infusion liquid to be delivered to a patient generally take the form of an infusion liquid bag, an infusion liquid bottle, and the like. A pre-filled syringe or vial is generally utilized to add a high concentration of a drug to the infusion liquid contents, via a liquid transfer device, to form a diluted, medicated infusion liquid. Thereafter, an infusion set including an IV spike may be inserted into an IV port of the liquid transfer device for infusion of medicated infusion liquid contents to a patient. Minimizing the risk of a patient receiving a portion of the drug in a highly concentrated, undiluted form is important for patient safety.

BRIEF SUMMARY OF THE DISCLOSURE

[0004] The present disclosure realizes the advantageous manufacture of a liquid transfer device having separate lumens: one for mixing the high concentration of drug with the infusion liquid, and one for transferring the diluted, medicated infusion liquid to the infusion set, as an added measure to prevent the patient from receiving a portion of the drug in an undiluted, high concentration form. The present disclosure additionally or alternatively realizes the advantageous manufacture of a liquid transfer device capable of mixing the fluid within the lumen between the IV port and the port connected to the medicated infusion liquid contents prior to administering the medicated infusion liquid contents to a patient.

Briefly stated, one aspect of the present disclosure is directed to a liquid transfer device configured for use with each of an infusion liquid container containing an infusion liquid and having an intravenous (IV) port for administering the infusion liquid, a vial containing a medicament additive sealed by a vial stopper, and an infusion set including an IV spike for sealing insertion into an IV port and a connector, such as an infusion set, for administration purposes to a patient. The liquid transfer device includes a monolithic trifurcated connector

body defining a barrel at a first end thereof, a single IV spike at a second end thereof and a vial adapter lumen at a third end thereof. An IV port is connected to the barrel and configured to sealingly receive the IV spike of the infusion set. A vial adapter is permanently secured to the vial adapter lumen and configured to telescopically mount onto the vial. The vial adapter includes a vial spike fluidly connected with the vial adapter lumen and configured to puncture the vial stopper upon mounting of the vial adapter onto the vial for flow communication therewith. The single IV spike is configured to sealingly insert into the IV port of the infusion liquid container. The single IV spike has a first IV spike lumen fluidly connected at a proximal end thereof with only the vial adapter lumen via the trifurcated connector body and a second IV spike lumen fluidly connected at a proximal end thereof with only the IV port via the trifurcated connector body, thereby separating fluid communication between the vial adapter and the single IV spike from fluid communication between the IV port and the single IV spike while enabling initial introduction of the medicament additive from the vial to the infusion liquid container through the vial adapter and the first IV spike lumen for mixing with the infusion liquid to form a medicated infusion liquid, and enabling subsequent administration of the medicated infusion liquid to a patient from the infusion liquid container through the second IV spike lumen and the IV port to the infusion set. The first IV spike lumen has a first peripherally disposed distal aperture and the second IV spike lumen has a second peripherally disposed distal aperture.

[0006] Briefly stated, another aspect of the present disclosure is directed to a method of using a liquid transfer device having a monolithic trifurcated connector body defining a barrel at a first end thereof, a single intravenous (IV) spike at a second end thereof and a vial adapter lumen at a third end thereof. The method includes the steps of mounting a vial adapter permanently secured to the vial adapter lumen onto a vial containing a medicament additive, and, in turn, piercing a stopper of the vial with a vial spike of the vial adapter fluidly connected with the vial adapter lumen; piercing an IV port of an infusion liquid container containing an infusion liquid with the single IV spike; and adding the medicament additive within the vial to the infusion liquid within the infusion liquid container (i.e. mixing the medicament with the infusion liquid) to obtain a medicated infusion liquid via the vial adapter lumen and a first IV spike lumen of the single IV spike. The first IV spike lumen is fluidly connected at a proximal end thereof with only the vial adapter lumen via the trifurcated connector body and has a first peripherally disposed distal aperture proximate a distal end of the single IV spike. The method also includes the step of inserting an IV spike of an infusion set into an IV port of the liquid transfer device, the IV port of the liquid transfer device being fluidly connected to a second IV

spike lumen of the single IV spike. The second IV spike lumen is fluidly connected at a proximal end thereof with only the IV port and has a second peripherally disposed distal aperture proximate the distal end of the single IV spike, thereby fluidly connecting the infusion set with the infusion liquid container for administration of the medicated infusion liquid to a patient.

[0006a] Briefly stated, another aspect of the present disclosure is directed to a liquid transfer device configured for use with each of an infusion liquid container containing an infusion liquid and having an intravenous administration port for administering the infusion liquid, a vial containing a medicament additive sealed by a vial stopper, and an infusion set including an IV port spike and a connector for administration purposes to a patient, the liquid transfer device comprising a monolithic trifurcated connector body defining a barrel at a first end thereof, a single IV spike at a second end thereof and a vial adapter lumen at a third end thereof; an IV port connected to the barrel and configured to sealingly receive the IV port spike of the infusion set; a vial adapter comprising the vial adapter lumen and configured to telescopically mount onto the vial, the vial adapter including a vial spike fluidly connected with the vial adapter lumen and configured to puncture the vial stopper upon mounting of the vial adapter onto the vial for flow communication therewith, and the single IV spike being configured to sealingly insert into the intravenous administration port of the infusion liquid container, and the single IV spike having a first IV spike lumen fluidly connected at a proximal end thereof with only the vial adapter lumen via the trifurcated connector body, the first IV spike lumen having a first peripherally disposed distal aperture; and a second IV spike lumen fluidly connected at a proximal end thereof with only the IV port via the trifurcated connector body, the second IV spike lumen having a second peripherally disposed distal aperture; thereby separating fluid communication between the vial adapter and the single IV spike from fluid communication between the IV port and the single IV spike while enabling initial introduction of the medicament additive from the vial to the infusion liquid container through the vial adapter and the first IV spike lumen for mixing with the infusion liquid to form a medicated infusion liquid, and enabling subsequent administration of the medicated infusion liquid to a patient from the infusion liquid container through the second IV spike lumen and the IV port to the infusion set.

[0006b] Briefly stated, another aspect of the present disclosure is directed to a method of using a liquid transfer device having a monolithic trifurcated connector body defining a barrel at a first end thereof, a single intravenous (IV) spike at a second end thereof and a vial adapter lumen at a third end thereof, the method comprising: mounting a vial adapter comprising the vial adapter lumen onto a vial containing a medicament additive, and, in turn,

piercing a stopper of the vial with a vial spike of the vial adapter fluidly connected with the vial adapter lumen; piercing an administration port of an infusion liquid container containing an infusion liquid with the single IV spike; adding the medicament additive within the vial to the infusion liquid within the infusion liquid container to obtain a medicated infusion liquid via the vial adapter lumen and a first IV spike lumen of the single IV spike, the first IV spike lumen being fluidly connected at a proximal end thereof with only the vial adapter lumen via the trifurcated connector body and having a first peripherally disposed distal aperture proximate a distal end of the single IV spike; and inserting an IV port spike of an infusion set into an IV port of the liquid transfer device, the IV port of the liquid transfer device being fluidly connected to a second IV spike lumen of the single IV spike, wherein the second IV spike lumen is fluidly connected at a proximal end thereof with only the IV port and having a second peripherally disposed distal aperture proximate the distal end of the single IV spike, thereby fluidly connecting the infusion set with the infusion liquid container for administration of the medicated infusion liquid to a patient.

[0006c] Briefly stated, another aspect of the present disclosure is directed to a liquid transfer device configured for use with each of an infusion liquid container containing an infusion liquid and having an intravenous administration port for administering the infusion liquid, a vial containing a medicament additive sealed by a vial stopper, and an infusion set including an IV port spike and a connector for administration purposes to a patient, the liquid transfer device comprising: a monolithic trifurcated connector body defining a barrel at a first end thereof, a single IV spike at a second end thereof and a vial adapter lumen at a third end thereof; an IV port connected to the barrel and configured to sealingly receive the IV port spike of the infusion set; a vial adapter comprising the vial adapter lumen and configured to telescopically mount onto the vial, the vial adapter including a vial spike fluidly connected with the vial adapter lumen and configured to puncture the vial stopper upon mounting of the vial adapter onto the vial for flow communication therewith, the single IV spike comprising an IV spike lumen and being configured to sealingly insert into the intravenous administration port of the infusion liquid container, and a plunger including a plunger tube defining a plunger tube lumen therein, wherein the barrel defines an internal chamber fluidly connected with the IV spike lumen and sealingly and slidably receiving the plunger tube, wherein plunger tube is fluidly connected with the IV port via a proximal end thereof and the plunger tube includes a check valve at a distal end thereof, whereby the IV port is fluidly connected with the second IV spike lumen in an open position of the check valve and fluidly disconnected from the second IV spike lumen in a closed position of the check valve.

[0006d] Briefly stated, another aspect of the present disclosure is directed to a liquid transfer device comprising a vial adapter configured to receive a vial and including a vial spike, the vial spike being configured to puncture a vial stopper of the vial and defining a vial spike lumen; an intravenous (IV) port configured to receive a port spike of an infusion set; and a connector body including a vial adapter lumen in fluid communication with the vial spike lumen, a barrel connected to the IV port, and an IV spike including a central wall and defining a first IV spike lumen in fluid communication with the vial adapter lumen and having a distal-facing aperture, and a second IV spike lumen in fluid communication with the IV port and having a side-facing aperture, wherein the first IV spike lumen and the second IV spike lumen are separated by the central wall.**[0006f]**

Briefly stated, another aspect of the present disclosure is directed to a liquid transfer device comprising a vial adapter configured to receive a vial and including a vial spike, the vial spike being configured to puncture a vial stopper of the vial and defining a vial spike lumen; an intravenous (IV) port configured to receive a port spike of an infusion set; and a connector body including: a vial adapter lumen in fluid communication with the vial spike lumen, a barrel connected to the IV port, and an IV spike including a central wall and defining: a first IV spike lumen being straight and in fluid communication with the vial adapter lumen and, and a second IV spike lumen being L-shaped and in fluid communication with the IV port, wherein the first IV spike lumen and the second IV spike lumen are separated by the central wall, and the central wall has a transverse protrusion forming a distal surface of the second IV spike lumen.

[0006g] Briefly stated, another aspect of the present disclosure is directed to a medicinal vial reconstitution and dispensing apparatus, comprising a receptacle including an apron and a vial spike configured to engage a medicinal vial, the vial spike being configured to penetrate a cap on the medicinal vial; an intravenous (IV) connector configured for inline connection to a patient IV line; and a bifurcated body extending from the IV connector and having an IV bag spike with a tapered end, the bifurcated body enclosing a first channel and a second channel, wherein the first channel is configured for fluid communication from the receptacle to an IV bag via a first orifice on the IV bag spike, the second channel is configured for transferring liquids from the IV bag to the IV connector via a second orifice on the IV bag spike, at least one of the first orifice and the second orifice is on a side of the IV bag spike, and the first orifice and the second orifice define respective fluidic connections to the receptacle and the patient IV line.

[0006h] Briefly stated, another aspect of the present disclosure is directed to a liquid transfer device comprising a vial adapter configured to receive a vial and including a vial spike,

the vial spike being configured to puncture a vial stopper of the vial and defining a vial spike lumen; an intravenous (IV) port configured to receive a port spike of an infusion set; and a connector body including: a vial adapter lumen in fluid communication with the vial spike lumen, a barrel connected to the IV port, and an IV spike including a central wall and defining: a first IV spike lumen in fluid communication with the vial adapter lumen and having a first aperture, and a second IV spike lumen in fluid communication with the IV port and having a second aperture lateral of a longitudinal axis of the second IV spike lumen, wherein the first IV spike lumen and the second IV spike lumen are separated by the central wall.

[0006i] Briefly stated, another aspect of the present disclosure is directed to a liquid transfer device comprising a vial adapter configured to receive a vial and including a vial spike, the vial spike being configured to puncture a vial stopper of the vial and defining a vial spike lumen; an intravenous (IV) port configured to receive a port spike of an infusion set; and a connector body including a vial adapter lumen in fluid communication with the vial spike lumen, a barrel connected to the IV port, and an IV spike including a central wall and defining: a first IV spike lumen in fluid communication with the vial adapter lumen, and a second IV spike lumen fluidly connected with the IV port, wherein the first IV spike lumen and the second IV spike lumen are separated by the central wall, and the central wall has a transverse protrusion forming a distal surface of the second IV spike lumen.

[0006j] Briefly stated, another aspect of the present disclosure is directed to a liquid transfer device comprising a vial adapter configured to receive a vial, the vial adapter including a skirt and a vial spike, the skirt being configured to telescopically receive the vial, and the vial spike being configured to puncture a vial stopper of the vial and defining a vial spike lumen; an intravenous (IV) port configured to receive a port spike of an infusion set, the IV port having an internal lumen and a septum configured to be punctured by the port spike of the infusion set; and a connector body including: a vial adapter lumen in fluid communication with the vial spike lumen, a barrel connected to the IV port, and an IV spike including a central wall and defining: a first IV spike lumen in fluid communication with the vial adapter lumen and having a distal-facing aperture aligned with a longitudinal axis of the first IV spike lumen, and a second IV spike lumen in fluid communication with the IV port and having a side-facing aperture lateral of a longitudinal axis of the second IV spike lumen, wherein the first IV spike lumen and the second IV spike lumen are separated by the central wall, the central wall has a transverse protrusion forming a distal surface of the second IV spike lumen, the barrel is aligned with a longitudinal axis of the IV spike, and the vial adapter lumen is angularly disposed from the longitudinal axis of the IV spike.

[0006k] Briefly stated, another aspect of the present disclosure is directed to a medicinal vial reconstitution and dispensing apparatus comprising a receptacle including an apron and a spike, the spike adapted to engage a medicinal vial and adapted for penetration of a resilient portion in a cap on the medicinal vial; an intravenous (IV) connector adapted for inline connection to a patient IV line, the IV connector adapted for transport of medicinal fluids to a patient via the patient IV line; and a bifurcated junction body having a transfer channel adapted for fluid communication between the receptacle and the IV connector, the bifurcated junction body having: a flow control element for ensuring a controlled flow path from the transfer channel to a fluid reservoir of an IV fluid bag before passing to the patient IV line through the IV connector, and an IV bag spike having a tapered end for engaging the IV fluid bag to establish fluid communication between the IV connector and the fluid reservoir, the IV bag spike having at least one of a first orifice and a second orifice on a side of the IV bag spike, the first orifice and the second orifice defining respective fluidic connections to the transfer channel and the patient IV line.

[0006l] Briefly stated, another aspect of the present disclosure is directed to a liquid transfer device configured for use with each of an infusion liquid container containing an infusion liquid and having an intravenous administration port for administering the infusion liquid, a vial containing a medicament additive sealed by a vial stopper, and an infusion set including an IV port spike and a connector for administration purposes to a patient, the liquid transfer device comprising: a monolithic trifurcated connector body defining a barrel at a first end thereof, an IV spike at a second end thereof and a vial adapter lumen at a third end thereof; an IV port connected to the barrel and configured to sealingly receive the IV port spike of the infusion set; and a vial adapter configured to telescopically mount onto the vial, the vial adapter including a vial spike fluidly connected with the vial adapter lumen and configured to puncture the vial stopper upon mounting of the vial adapter onto the vial for flow communication therewith, the IV spike being configured to sealingly insert into the intravenous administration port of the infusion liquid container, and the IV spike having: a first IV spike lumen fluidly connected at a proximal end thereof with the vial adapter lumen via the monolithic trifurcated connector body, the first IV spike lumen having a first peripherally disposed distal aperture; and a second IV spike lumen fluidly connected at a proximal end thereof with the IV port via the monolithic trifurcated connector body, the second IV spike lumen having a second peripherally disposed distal aperture, thereby separating fluid communication between the vial adapter and the IV spike from fluid communication between the IV port and the IV spike while enabling initial introduction of the medicament additive from the vial to the infusion liquid

container through the vial adapter and the first IV spike lumen for mixing with the infusion liquid to form a medicated infusion liquid, and enabling subsequent administration of the medicated infusion liquid to the patient from the infusion liquid container through the second IV spike lumen and the IV port to the infusion set, wherein the first IV spike lumen extends further distally than the second IV spike lumen, the first peripherally disposed distal aperture and the second peripherally disposed distal aperture are non-overlapping longitudinally, and the first peripherally disposed distal aperture is distally separated from the second peripherally disposed distal aperture by at least about 1.0 mm.

[0006m] Briefly stated, another aspect of the present disclosure is directed to a method of using a liquid transfer device having a monolithic trifurcated connector body defining a barrel at a first end thereof, a single intravenous (IV) spike at a second end thereof and a vial adapter lumen at a third end thereof, the method comprising: mounting a vial adapter comprising the vial adapter lumen onto a vial containing a medicament additive, and piercing a stopper of the vial with a vial spike of the vial adapter fluidly connected with the vial adapter lumen; piercing an administration port of an infusion liquid container containing an infusion liquid with the IV spike; adding the medicament additive within the vial to the infusion liquid within the infusion liquid container to obtain a medicated infusion liquid via the vial adapter lumen and a first IV spike lumen of the IV spike, the first IV spike lumen being fluidly connected at a proximal end thereof with the vial adapter lumen and having a first peripherally disposed distal aperture proximate a distal end of the IV spike; and inserting an IV port spike of an infusion set into an IV port of the liquid transfer device, the IV port of the liquid transfer device being fluidly connected to a second IV spike lumen of the IV spike, wherein the second IV spike lumen is fluidly connected at a proximal end thereof with the IV port and having a second peripherally disposed distal aperture proximate the distal end of the IV spike, thereby fluidly connecting the infusion set with the infusion liquid container for administration of the medicated infusion liquid to a patient, and wherein the first IV spike lumen extends further distally than the second IV spike lumen, the first peripherally disposed distal aperture and the second peripherally disposed distal aperture are non-overlapping longitudinally, and the first peripherally disposed distal aperture is distally separated from the second peripherally disposed distal aperture by at least about 1.0 mm.

[0006n] Briefly stated, another aspect of the present disclosure is directed to a liquid transfer device configured for use with each of an infusion liquid container containing an infusion liquid and having an intravenous administration port for administering the infusion liquid, a vial containing a medicament additive sealed by a vial stopper, and an infusion set

including an IV port spike and a connector for administration purposes to a patient, the liquid transfer device comprising: a monolithic trifurcated connector body defining a barrel at a first end thereof, an IV spike at a second end thereof and a vial adapter lumen at a third end thereof; an IV port connected to the barrel and configured to sealingly receive the IV port spike of the infusion set; a vial adapter comprising the vial adapter lumen and configured to telescopically mount onto the vial, the vial adapter including a vial spike fluidly connected with the vial adapter lumen and configured to puncture the vial stopper upon mounting of the vial adapter onto the vial for flow communication therewith, the IV spike comprising an IV spike lumen and being configured to sealingly insert into the intravenous administration port of the infusion liquid container; and a plunger including a plunger tube defining a plunger tube lumen therein, wherein the barrel defines an internal chamber fluidly connected with the IV spike lumen and sealingly and slidably receiving the plunger tube, wherein the plunger tube is fluidly connected with the IV port via a proximal end thereof, and the plunger tube includes a check valve at a distal end thereof, whereby the IV port is fluidly connected with the IV spike lumen in an open position of the check valve and fluidly disconnected from the IV spike lumen in a closed position of the check valve.

[0006o] Briefly stated, another aspect of the present disclosure is directed to a liquid transfer device configured for use with each of an infusion liquid container containing an infusion liquid and having an intravenous administration port for administering the infusion liquid, a vial containing a medicament additive sealed by a vial stopper, and an infusion set including an IV port spike and a connector for administration purposes to a patient, the liquid transfer device comprising: a monolithic trifurcated connector body defining a barrel at a first end thereof, an IV spike at a second end thereof and a vial adapter lumen at a third end thereof; an IV port connected to the barrel and configured to sealingly receive the IV port spike of the infusion set; a vial adapter configured to telescopically mount onto the vial, the vial adapter including a vial spike fluidly connected with the vial adapter lumen and configured to puncture the vial stopper upon mounting of the vial adapter onto the vial for flow communication therewith, the IV spike being configured to sealingly insert into the intravenous administration port of the infusion liquid container, and the IV spike having: a first IV spike lumen fluidly connected at a proximal end thereof with the vial adapter lumen via the monolithic trifurcated connector body, the first IV spike lumen having a first peripherally disposed distal aperture; and a second IV spike lumen fluidly connected at a proximal end thereof with the IV port via the monolithic trifurcated connector body, the second IV spike lumen having a second peripherally disposed distal aperture, thereby separating fluid communication between the vial

adapter and the IV spike from fluid communication between the IV port and the IV spike while enabling initial introduction of the medicament additive from the vial to the infusion liquid container through the vial adapter and the first IV spike lumen for mixing with the infusion liquid to form a medicated infusion liquid, and enabling subsequent administration of the medicated infusion liquid to the patient from the infusion liquid container through the second IV spike lumen and the IV port to the infusion set; and a plunger including a plunger tube defining a plunger tube lumen therein, wherein the barrel defines an internal chamber fluidly connected with the second IV spike lumen and sealingly and slidably receiving the plunger tube.

[0006p] Briefly stated, another aspect of the present disclosure is directed to a liquid transfer device comprising: a barrel configured to fluidly connect to an infusion set; a vial adapter in communication with a vial adapter lumen and having a vial spike, the vial spike being configured to puncture a stopper of a vial containing a medicament, and the vial adapter being configured to receive the vial; and an intravenous (IV) spike configured to be sealingly inserted into an intravenous administration port of a container of an infusion liquid, the IV spike having a first IV spike lumen fluidly connected to the vial adapter lumen, and a second IV spike lumen fluidly connected to the infusion set, wherein the liquid transfer device defines a first fluid path and a second fluid path, the first fluid path is through the vial adapter lumen and the first IV spike lumen to introduce medicament from the vial to the container for mixing with the infusion liquid to form a medicated infusion liquid, and the second fluid path is through the second IV spike lumen to pass the medicated infusion liquid from the container to the infusion set.

BRIEF DESCRIPTION OF THE DRAWINGS

[0007] The following detailed description of aspects of the disclosure will be better understood when read in conjunction with the appended drawings. It should be understood, however, that the disclosure is not limited to the precise arrangements and instrumentalities shown. In the drawings:

[0008] Fig. 1A is a front elevational view of an infusion liquid container in the form of a bag usable with a liquid transfer device according to the present disclosure;

[0009] Fig. 1B is a front elevational view of an infusion liquid container in the form of a flexible bottle usable with a liquid transfer device according to the present disclosure;

[0010] Fig. 1C is a front elevational view of a pre-filled needleless syringe and a vial usable with the liquid transfer device according to the present disclosure;

[0011] Fig. 1D is a front elevational view of an infusion set usable with the liquid transfer device according to the present disclosure;

[0012] Fig. 2A is a perspective view of the liquid transfer device, in accordance with a first embodiment of the present disclosure, in a depressed plunger configuration;

[0013] Fig. 2B is a cross-sectional elevational view of the liquid transfer device of Fig. 2A, taken along sectional line 2B-2B of Fig. 2A;

[0014] Fig. 3 is a perspective view of the syringe plunger and an IV port of the liquid transfer device of Fig. 2A;

[0015] Fig. 4A is a perspective view of the liquid transfer device according to the present disclosure, in a withdrawn plunger configuration;

[0016] Fig. 4B is a cross-sectional elevational view of the liquid transfer device of Fig. 4A, taken along sectional line 4B-4B of Fig. 4A;

[0017] Fig. 5 is a cross-sectional elevational view of another embodiment of a liquid transfer device having an alternatively configured IV spike;

[0018] Fig. 6 is a cross-sectional elevational view of the liquid transfer device of Fig. 2A, taken along sectional line 2B-2B of Fig. 2A, having another alternatively configured IV spike;

[0019] Fig. 7A is an enlarged cross-sectional elevational view of one configuration of a vial adapter of the liquid transfer device of Fig. 2A;

[0020] Fig. 7B is an enlarged cross-sectional elevational view of another configuration of a vial adapter of the liquid transfer device of Fig. 2A;

[0021] Fig. 8 is a perspective view of a liquid transfer device, in accordance with a second embodiment of the present disclosure;

[0022] Fig. 9 is a cross-sectional elevational view of the liquid transfer device of Fig. 8, taken along sectional line 9-9 of Fig. 8; and

[0023] Fig. 10 is an enlarged partial, exploded, perspective view of an alternative attachment between a trifurcated connector body and an elongate connecting member, such as an IV port, of the liquid transfer device of Fig. 8.

[0024] Figs. 11A and 11B are cross-sectional elevational views of another embodiment of the liquid transfer device of Fig. 6 having an internal valve.

DETAILED DESCRIPTION OF THE DISCLOSURE

[0025] Certain terminology is used in the following description for convenience only and is not limiting. The words “lower,” “bottom,” “upper” and “top” designate directions in the drawings to which reference is made. The words “inwardly,” “outwardly,” “upwardly” and “downwardly” refer to directions toward and away from, respectively, the geometric center of the liquid transfer device, and designated parts thereof, in accordance with the present disclosure. Unless specifically set forth herein, the terms “a,” “an” and “the” are not limited to one element, but instead should be read as meaning “at least one.” The terminology includes the words noted above, derivatives thereof and words of similar import.

[0026] It should also be understood that the terms “about,” “approximately,” “generally,” “substantially” and like terms, used herein when referring to a dimension or characteristic of a component of the disclosure, indicate that the described dimension/characteristic is not a strict boundary or parameter and does not exclude minor variations therefrom that are functionally similar. At a minimum, such references that include a numerical parameter would include variations that, using mathematical and industrial principles accepted in the art (e.g., rounding, measurement or other systematic errors, manufacturing tolerances, etc.), would not vary the least significant digit.

[0027] Referring to the drawings in detail, wherein like numerals indicate like elements throughout, there is shown in Figs. 2A-6 a liquid transfer device 30, in accordance with a first embodiment of the present disclosure, intended for use with the combination of infusion liquid

containers containing an infusion liquid and additive transfer devices. In the illustrated embodiment, the liquid transfer device 30 is intended for use with an infusion liquid container in the form of an infusion liquid bag 10 (Fig. 1A). As should be understood by those of ordinary skill in the art, a conventional infusion liquid bag 10 includes a reservoir 12 containing infusion liquid, in fluid communication with an intravenous administration port 14 and an additive port 16. The infusion liquid bag 10 is collapsible upon administration of the infusion liquid therefrom. The liquid transfer device 30 may also be used with an infusion liquid container in the form of a flexible infusion liquid bottle 18 (Fig. 1B) or the like. The liquid transfer device 30 of the illustrated embodiment is also intended for use with an additive transfer device in the form of a sealed vial 20 (Fig. 1C). The vial 20 generally contains a highly concentrated medicament liquid additive or a lyophilized powder drug requiring reconstitution prior to administration to a patient, i.e., requiring mixing with the infusion liquid in the bag 10 to form a medicated infusion liquid administered to a patient. The contents of the vial 20 are, therefore, introduced into the infusion liquid bag 10 via the liquid transfer device 30 (as will be described in further detail below). The liquid transfer device 30 may also, however, take a different configuration intended for use with a syringe 22 (Fig. 1C) containing a medicament liquid additive.

[0028] The liquid transfer device 30 includes a trifurcated connector body 32. In the illustrated embodiment of Figs. 2A-6, the trifurcated connector body 32 is a monolithic body defining a barrel 34 at a first end thereof, a single IV spike 36 at a second end thereof, and a vial adapter 38 at a third end thereof, but the disclosure is not so limited (as described further below). As shown best in Figs. 2B, 4B and 5, the barrel 34 defines an internal chamber 34a having an open proximal end 34b for slidably receiving a plunger 40 (as will be described further below). The IV spike 36 defining the second end of the trifurcated body 32 enables use of the liquid transfer device 30 with infusion liquid bags 10, i.e., for sealingly inserting the IV spike 36 into the administration port 14 of the bag 10. The IV spike 36 may be constructed from a suitable rigid metal, polymeric or plastic material, such as, for example, polycarbonate and the like. A flange 33 extends laterally from the IV spike 36 proximate a proximal end thereof to provide a gripping or bearing surface to enable a user to more easily insert the IV spike 36 into a liquid container, such as bag 10. The IV spike may optionally include a feature, such as raised step 35 around the circumferential surface of the IV spike 36, for restricting insertion depth into the administration port 14 of the bag 10. In one embodiment, the flange 33 may also be formed as an injection molded monolithic structure with the connector body

32, but the disclosure is not so limited. A spike cap (not shown) may removably cover the IV spike 36 when not in use.

[0029] As shown, the IV spike 36 is co-directional and/or coaxial with the barrel 34 and includes two internal lumens 36a, 36b. In the illustrated configurations, the lumens 36a, 36b extend generally parallel to one another. The first IV spike lumen 36a is continuously and directly fluidly connected at a proximal end with only a vial adapter lumen 37 located within the vial adapter 38 angularly bifurcating from, i.e., branching off of, the IV spike 36. The first IV spike lumen 36a includes a first peripherally disposed distal aperture 36c. As shown best in Figs. 2B, 4B and 5, the first IV spike lumen 36a is not fluidly connected at the proximal end thereof with the barrel chamber 34a. The second IV spike lumen 36b is directly fluidly connectable at a proximal end with only the barrel chamber 34a and includes a second peripherally disposed distal aperture 36d, separate from the first distal aperture 36c of the first IV spike lumen 36a. The second IV spike lumen 36b is not fluidly connected at the proximal end thereof with the vial adapter lumen 37 or at any point along the length of the IV spike 36. In other words, IV spike 36 includes two separate lumens 36a, 36b that extend through the IV spike 36 to provide discrete fluid paths that are not connected within the IV spike 36. Thus, fluid communication between the vial adapter 38 and the IV spike 36 is separate from fluid communication between the barrel chamber 34a and the IV spike 36.

[0030] The vial adapter 38 is configured to mount onto a vial 20 to enable usage of the device 30 with an additive transfer device in the form of a vial 20. In one configuration, the vial adapter 38 may be integrally formed at the third end of the connector body 32, i.e., monolithically formed with the terminal end of the vial adapter lumen 37 or otherwise permanently secured and sealed to the terminal end of the vial adapter lumen 37, but the disclosure is not so limited. As used herein through the specification and the claims, “permanently secured” means not disconnectable/removable without causing damage to the device or portion thereof. As one non-limiting example, the vial adapter 38 may be ultrasonically welded to the vial adapter lumen 37.

[0031] Referring to Fig. 7A, the vial adapter 38 includes a top wall 38d, a flexible and/or flared skirt 38a depending therefrom for telescopic snap fit mounting onto a vial 20 (in a standard manner) and a vial spike 38b for puncturing the vial 20, e.g., through a stopper thereof, to fluidly communicate with the interior of the vial 20. The puncturing vial spike 38b includes a lumen 38c in fluid communication with the vial adapter lumen 37, and, in turn with the first IV spike lumen 36a. As should be understood by those of ordinary skill in the art, the inner

diameter of the vial spike 38b, i.e., the diameter of the lumen 38c, and/or the outer diameter of the vial spike 38b may be dimensioned as appropriate for the intended use.

[0032] In the configuration of Fig. 7A, the vial spike 38b includes a base section 39 that is generally concave with respect to the axis of the vial spike 38b. The vial adapter 38 may alternatively be configured to minimize/protect against leakage resulting from the tear that forms in the stopper of a vial 20 as the vial adapter 38 is pushed down onto the vial 20 and the vial spike 38b advances through the stopper. As illustrated in the configuration of Fig. 7B, the direction of extension of the base section 39' is generally convex with respect to the axis of the vial spike 38b such that the base section 39' has a generally bulbous configuration. When the vial adapter 38 is pushed down onto the vial 20 and the spike 38b advances through the vial stopper, the base section 39' is compressed against an upper surface of the vial stopper and the compressed material of the vial stopper surrounds tears formed in the vial stopper for sealing thereof. Puncturing of the vial stopper by the vial spike 38b is generally accompanied by the formation of a depression in the upper surface of the vial stopper. The convex base section 39' is configured to fill in the depression, thereby minimizing/protecting against leakage. As should be understood by those of ordinary skill in the art, however, different sealing base sections/means, currently known, or that later become known, may be employed to minimize leakage between the vial spike 38b and the elastic stopper of vial 20. As also should be understood, other vial adapter configurations, currently known, or that later become known, may alternatively be employed.

[0033] Turning to the plunger 40, as shown best in Figs. 2B, 3, 4B and 5, the plunger 40 includes an upright plunger tube 46, defining a plunger tube lumen 46a therein. The plunger tube 46 is slidably engaged with the barrel 34 via a peripheral sealing member 42 (constructed, for example, of an elastomeric material or the like) interposed therebetween in a manner well understood by those of ordinary skill in the art, permitting sliding within the barrel 34 while creating a substantially air-tight seal between the plunger tube 46 and the interior sidewall of the barrel 34. The plunger tube 46 and the sealing member 42, in combination with the barrel 34, define a sealed proximal end of the barrel chamber 34a. The plunger tube 46 includes a distal, elongate neck portion 44 terminating in a check valve 48. In the illustrated embodiment, the check valve 48 takes the form of a duckbill valve, constructed of an elastomeric material or the like, but the disclosure is not so limited. For example, without limitation, the check valve 48 may take the form of several other types of one-way valves, such as, for example, a ball valve, a silicone flapper valve, a diaphragm-type valve, an in-line valve, a stop-check

valve, a lift-check valve, or the like, capable of performing the functions of the check valve 48 described herein.

[0034] As shown, an IV port 50 is fluidly connected with a proximal end of the plunger tube 46. The IV port 50 includes a twist-off member 50a proximate a peripheral, free proximal end of the port 50, and an elongate connecting member 52 projecting distally therefrom, having an internal lumen 52a extending therethrough and terminating in an open end (opposite end from the twist-off member 50a). The internal lumen 52a of the IV port 50 extends co-directionally and/or coaxially with the plunger lumen 46a. In one embodiment, the IV port 50 may be constructed from a suitable flexible polymeric or plastic material, such as, for example, PVC, and the like. In the illustrated embodiment, the elongate connecting member 52 is adhered, i.e., adhesively bonded, with the plunger tube 46, but the disclosure is not so limited. For example, without limitation, the elongate connecting member 52 may be permanently secured and rotationally fixedly attached to the plunger tube 46 (for example, as described in further detail below with respect to Figs. 8 to 10).

[0035] The IV port 50 includes a septum 50b positioned within the elongate connecting member 52, sealing across the internal lumen 52a. Accordingly, the twist-off member 50a may be removed without leading to flow communication beyond the septum 50b. Flow communication beyond the septum 50b, i.e., with the plunger lumen 46a and beyond, is only achieved upon puncturing the septum 50b (as described in further detail below). The twist off member 50a keeps the IV port 50, and particularly the septum 50b, sterile until use.

[0036] In use, the liquid transfer device 30 may be coupled to an infusion liquid bag 10 via the IV spike 36 (as previously described). Thereafter, the user withdraws the plunger 40 in a proximal direction, i.e. in a direction away from the IV spike 36 (Figs. 4A, 4B). Alternatively, a dedicated handle may be employed and attached to the plunger 40 for translation thereof. Withdrawal of the plunger 40, with the distal aperture 36d immersed in the infusion liquid within the bag 10, pulls fluid from the bag 10, through the distal aperture 36d, through the second IV spike lumen 36b and into the barrel chamber 34a. The duckbill valve 48 is configured to prevent fluid flow into the plunger tube lumen 46a during plunger 40 withdrawal. As should be understood by those of ordinary skill in the art, withdrawal of the plunger 40 creates a vacuum in the barrel chamber 34a, resulting in a pressure difference relative to the infusion liquid bag 10, thereby pulling the fluid into the barrel chamber 34a. As also should be understood, the infusion liquid remains within the barrel chamber 34a and the second IV spike lumen 36b until manually ejected, in a manner well understood by those of ordinary skill in the art, as will be described below.

[0037] Prior or subsequent to withdrawing infusion liquid from the infusion liquid bag 10 into the barrel chamber 34a, the liquid transfer device 30 may be coupled to a vial 20 via the vial adapter 38 (as previously described). A user may mix/combine the contents within the vial 20 with the contents within the infusion liquid bag 10 via the vial adapter lumen 37 and the first IV spike lumen 36a by inverting the infusion liquid bag 10 and device 30, i.e. positioning the vial 20 above the bag 10, so that the contents of the vial 20 drain into the infusion liquid bag 10. Where the vial 20 contains a lyophilized powder drug, the drug can be reconstituted in a similar fashion. After coupling the vial 20 to the liquid transfer device 30, the liquid bag 10 is held above the vial 20, so that liquid from the liquid bag 10 drains into the vial 20 and reconstitutes the contents of the vial 20. The infusion liquid bag 10 and device 30 may then be inverted, as previously described, to drain the reconstituted contents of the vial 20 into the bag 10.

[0038] After mixing/combining the contents within the infusion liquid bag 10 and the vial 20 and orienting the liquid transfer device 30 such that the combined liquid flows into the infusion liquid bag 10, the plunger 40 is depressed until at least portion of the duckbill valve 48 engages the proximal end/rim of the second IV spike lumen 36b. In the illustrated embodiment, at least one of the elastomeric lips/flaps of the duckbill valve 48 abuts, and is displaced/compressed by, the proximal end 41 of the second IV spike lumen 36b, thereby opening the duckbill valve 48 for fluid-flow therethrough. That is, sustained pressure applied onto at least one of the elastomeric lips/flaps of the duckbill valve 48, resulting from the depression of the plunger 40 to a position engaging the valve 48 with the proximal end/rim 41 of the second IV spike lumen 36b, displaces the elastomeric lips/flaps of the valve 48 from one another, thereby breaking the seal therebetween and permitting fluid flow therethrough. Thereafter, the twist-off member 50a is removed (in a manner well understood) to provide access to the internal lumen 52a. An IV port spike 96 of an infusion set 95 (Fig. 1D) is sealingly inserted into the internal lumen 52a and fully penetrates the septum 50b, thereby fluidly connecting the IV port spike 96 with any remainder of the internal lumen 52a beyond the septum 50b, and, in turn, with the plunger lumen 46a and the second IV spike lumen 36b (via the open duckbill valve 48) for administration of the medicated infusion liquid to a patient. The IV port spike 96 typically extends from an end of a drip chamber 97a of the infusion set 95. Conventionally, an infusion set 95 additionally includes a roller clamp 97c for controlling fluid administration to a patient, a male Luer connector 97d, and tubing 97b to fluidly connect the roller clamp 97c to the drip chamber 97a.

[0039] Advantageously, the medicated infusion liquid is fluidly connected to the infusion set 95 via the second IV spike lumen 36b rather than the first IV spike lumen 36a, which is utilized only to admix the highly concentrated drug additive within the vial 20 with the infusion liquid within the bag 10. Thus, the possibility of administering a portion of the drug additive in an undiluted, high concentration form to a patient is minimized. Moreover, as the plunger 40 is depressed (as previously described), infusion liquid within the barrel chamber 34a is ejected through the second IV spike lumen 36b and out the distal aperture 36d. Therefore, after utilizing the liquid transfer device 30 to admix the contents within the infusion liquid bag 10 and the vial 20, the second IV spike lumen 36b and the distal aperture 36d thereof, though not utilized for mixing, are nevertheless flushed out prior to use thereof for transferring the medicated infusion liquid from the bag 10 to the infusion set 95, to further minimize the possibility of administering a portion of the drug additive in an undiluted, high concentration form to a patient.

[0040] In an alternative configuration, as shown in Fig. 5, a distal end of the IV spike 36' is configured such that the first IV spike lumen 36a' extends further distally than the second IV spike lumen 36b'. Advantageously, therefore, the first distal aperture 36c' is separated by a distance "d" from the distal aperture 36d', thereby further minimizing the opportunity for a portion of the drug in an undiluted, high concentration form from exiting the first distal aperture 36c' and entering the distal aperture 36d'. The distance "d" is preferably greater than or equal to about 1.0 mm, more preferably greater than or equal to about 2.5 mm, and most preferably greater than or equal to about 4.0 mm.

[0041] In another alternative configuration, as shown in Fig. 6, the IV spike 36'' may include a single lumen 36a'' with a single distal aperture 36c''. This configuration operates in a similar manner as with the configuration shown in Figs. 2-4B, except that withdrawing/ejecting fluid from or into the barrel chamber 34a and mixing the drug with fluid occurs in part through a common portion of the single lumen 36a''. Flushing of the lumen 36a'', as previously described, is performed between the steps of mixing/combining the contents within the infusion liquid bag 10 and the vial 20, and removing the twist-off member 50a for connection of the infusion set 95.

[0042] In a preferred embodiment illustrated in Figures 11A and 11B, a flow control valve 43 may be incorporated in the device, such that rotation of the flow control valve 43 allows a user to selectively fluidly connect either the vial adapter lumen 37 or the barrel chamber 34a with the single lumen 36a''. The valve 43 may prevent any highly concentrated drug additive within the vial 20 from being drawn into the barrel chamber 34a when the plunger tube 46 is

withdrawn, as illustrated in Fig. 11A. Prior to mixing the contents of the vial 20 into the bag 10, the valve 43 may be rotated in order to provide a fluid connection between the vial adapter lumen 37 and the single lumen 36a", as well as seal off the barrel chamber 34a, as illustrated in Fig. 11B. In order to flush the volume of liquid within the single lumen 36a", the valve 43 may be rotated back to its original position in Fig. 11A prior to depressing the plunger tube 46.

[0043] In another alternative embodiment, the vial adapter 38 may be detachable. For example, the device may be provided with a valve, such as the needleless additive control valve disclosed in U.S. Patent No. 8,551,067. The valve would allow the vial adapter 38 to be detached prior to withdrawing the plunger tube 46. The vial adapter 38 and vial 20 would then be connected via the valve to empty the highly concentrated contents of the vial 20 into the bag 20 followed by depression of the plunger tube 46 to flush the single lumen 36a".

[0044] Figs. 8-10 illustrate a second embodiment of the liquid transfer device 130. The reference numerals of the second embodiment are distinguishable from those of the above-described first embodiment configurations (Figs. 2A-7B) by a factor of one-hundred (100), but otherwise indicate the same elements as indicated above, except as otherwise specified. The liquid transfer device 130 of the present embodiment is similar to that of the first embodiment configurations. Therefore, the description of certain similarities and modes of operation between the embodiments may be omitted herein for the sake of brevity and convenience, and, therefore, is not limiting.

[0045] One difference of the liquid transfer device 130 over the liquid transfer device 30 pertains to the configuration of the first end of connector body 132. As shown in Figs. 8 and 9, the plunger 40 is removed and the IV port 150 is directly and permanently secured and sealed to the barrel 134, i.e., not disconnectable/removable without causing damage to at least one of the IV port 150 or the barrel 134 or otherwise to the device 130. Accordingly, the second IV spike lumen 136b of the single IV spike 136 is in direct and continuous fluid communication at a proximal end with only the internal lumen 152a of the elongate connecting member 152 of the IV port 150, while remaining not fluidly connected at the proximal end thereof with the vial adapter lumen 137. The first IV spike lumen 136a of the single IV spike 136 also remains continuously and directly fluidly connected at a proximal end with only the vial adapter lumen 137 and not fluidly connected at the proximal end thereof with the internal lumen 152a of the elongate connecting member 152.

[0046] In the illustrated embodiment of Figs. 8 and 9, the elongate connecting member 152 is adhered, i.e., adhesively bonded, with the barrel 134. As previously noted, the elongate

connecting member 152 may be permanently secured attached to the barrel 134. For example, as shown in Fig. 10, the barrel 134 may terminate in a barbed fitting member 154 having an open end 154a. The barbed fitting member 154 may be configured, i.e., size, dimension, material, relative to the internal diameter and material of the elongate connecting member 152 to advance into the internal lumen 152a and form a barbed, friction, i.e., interference, fit therebetween. As should be understood by those of ordinary skill in the art, the orientation of the barbed fitting member 154 permits advancement thereof into the internal lumen 152a to sealingly and securely mount the IV port 150 co-directionally upon the barrel 134 of the connector body 132, and also substantially prevent withdrawal of the barbed fitting member 154 without damaging at least one of the elongate connecting member 152 and the barbed fitting member 154.

[0047] As shown, the barbed fitting member 154 is frustoconically shaped, having a progressively increasing diameter in a direction away from the open end 154a. An opposing end of the barbed fitting member 154 defines a greater diameter from the underlying portion of the barrel 134, resulting in an annular rib 156 that provides an interference fit with the interior sidewall of the elongate connecting member 152, upon attempted withdrawal of the barbed fitting member 154 out of the elongate connecting member 152. Accordingly, the barbed fitting member 154 is advanceable into the internal lumen 152a of the elongate connecting member 152 during assembly, and, thereafter, is not readily able to be withdrawn without causing damage.

[0048] Additionally, the rim of the elongate connecting member 152 defining an open end 152b thereof includes at least one cutout 158a, and the barrel 134 includes a corresponding at least one radial tab 158b protruding from the barrel 134 and configured to mate with the at least one cutout 158a. In the illustrated embodiment, the elongate connecting member 152 includes a plurality of angularly spaced cutouts 158a, and the barrel 134 includes a corresponding plurality of angularly spaced tabs 158b. The tab(s) 158b mates with the cutout(s) 158a during mounting of the IV port 150 upon the barbed fitting member 154 of the barrel 134, to rotationally fix the IV port 150 relative to the remainder of the liquid transfer device 130. The tab(s) 158b also prevent relative rotation between the barrel 134 and the elongate connecting member 152 and enable a twist-off member 150a to be removed, as noted below, prior to connection to the infusion set 95.

[0049] In use, the liquid transfer device 130 may be coupled to a vial 20 via the vial adapter 138 and the user may mix/combine the contents within the vial 20 with the contents within the infusion liquid bag 10, via the vial adapter lumen 137 and the first IV spike lumen 136a. After

mixing/combining the contents within the infusion liquid bag 10 and the vial 20 and orienting the liquid transfer device 130 such that the combined liquid flows into the infusion liquid bag 10, the twist-off member 150a is removed (in a manner well understood) to provide access to the internal lumen 152a and the IV port spike 96 of an infusion set 95 (Fig. 1D) is sealingly inserted into the internal lumen 152a and fully penetrates the septum 150b, thereby fluidly connecting the IV port spike 96 with any remainder of the internal lumen 152a beyond the septum 150b, and, in turn, with the second IV spike lumen 136b for administration of the medicated infusion liquid to a patient.

[0050] It will be appreciated by those skilled in the art that changes could be made to the embodiments described above without departing from the broad inventive concepts thereof. For example instead of a vial adapter, the trifurcated connector body 32, 134 may include a normally closed (NC) needleless additive port (not shown) at the third end thereof (enabling selection of use with a syringe 22 or with a vial 20). As another example, the vial adapter 38, 138 can be replaced by a manually operated stop cock, and the like. As yet another example, the liquid transfer device 30 may include a locking mechanism to stabilize and/or lock the plunger 40 in the different positions thereof. It is understood, therefore, that this invention is not limited to the particular embodiments disclosed, but it is intended to cover modifications within the spirit and scope of the present disclosure, as set forth in the appended claims.

CLAIMS

We claim:

1. A liquid transfer device configured for use with each of an infusion liquid container containing an infusion liquid and having an intravenous administration port for administering the infusion liquid, a vial containing a medicament additive sealed by a vial stopper, and an infusion set including an IV port spike and a connector for administration purposes to a patient, the liquid transfer device comprising:

a monolithic trifurcated connector body defining a barrel at a first end thereof, a single IV spike at a second end thereof and a vial adapter lumen at a third end thereof;

an IV port connected to the barrel and configured to sealingly receive the IV port spike of the infusion set;

a vial adapter comprising the vial adapter lumen and configured to telescopically mount onto the vial, the vial adapter including a vial spike fluidly connected with the vial adapter lumen and configured to puncture the vial stopper upon mounting of the vial adapter onto the vial for flow communication therewith, and

the single IV spike being configured to sealingly insert into the intravenous administration port of the infusion liquid container, and the single IV spike having:

a first IV spike lumen fluidly connected at a proximal end thereof with only the vial adapter lumen via the trifurcated connector body, the first IV spike lumen having a first peripherally disposed distal aperture; and

a second IV spike lumen fluidly connected at a proximal end thereof with only the IV port via the trifurcated connector body, the second IV spike lumen having a second peripherally disposed distal aperture;

thereby separating fluid communication between the vial adapter and the single IV spike from fluid communication between the IV port and the single IV spike while enabling initial introduction of the medicament additive from the vial to the infusion liquid container through the vial adapter and the first IV spike lumen for mixing with the infusion liquid to form a medicated infusion liquid, and enabling subsequent administration of the medicated infusion liquid to a patient from the infusion liquid container through the second IV spike lumen and the IV port to the infusion set.

2. The liquid transfer device of claim 1,
wherein the first IV spike lumen is directly and continuously fluidly connected with only the vial adapter lumen.
3. The liquid transfer device of claim 2,
wherein the second IV spike lumen is directly and continuously fluidly connected with only the IV port.
4. The liquid transfer device of any one of claims 1 to 3,
wherein the IV port is permanently secured to the barrel.
5. The liquid transfer device of any one of claims 1 to 4,
wherein the first IV spike lumen extends further distally than the second IV spike lumen,
whereby the first peripherally disposed distal aperture is distally spaced from the second peripherally disposed distal aperture along the single IV spike.
6. The liquid transfer device of any one of claim 1 to 5s,
further comprising a plunger including a plunger tube defining a plunger tube lumen therein,
wherein the barrel defines an internal chamber fluidly connected with the second IV spike lumen and sealingly and slidably receiving the plunger tube.
7. The liquid transfer device of claim 6,
wherein the plunger tube is fluidly connected with the IV port via a proximal end thereof and the plunger tube includes a check valve at a distal end thereof, whereby the IV port is fluidly connected with the second IV spike lumen in an open position of the check valve and fluidly disconnected from the second IV spike lumen in a closed position of the check valve.
8. The liquid transfer device of any one of claims 1 to 7,
wherein the first IV spike lumen and the second IV spike lumen extend parallel to one another.

9. A method of using a liquid transfer device having a monolithic trifurcated connector body defining a barrel at a first end thereof, a single intravenous (IV) spike at a second end thereof and a vial adapter lumen at a third end thereof,

the method comprising:

mounting a vial adapter comprising the vial adapter lumen onto a vial containing a medicament additive, and, in turn, piercing a stopper of the vial with a vial spike of the vial adapter fluidly connected with the vial adapter lumen;

piercing an administration port of an infusion liquid container containing an infusion liquid with the single IV spike;

adding the medicament additive within the vial to the infusion liquid within the infusion liquid container to obtain a medicated infusion liquid via the vial adapter lumen and a first IV spike lumen of the single IV spike, the first IV spike lumen being fluidly connected at a proximal end thereof with only the vial adapter lumen via the trifurcated connector body and having a first peripherally disposed distal aperture proximate a distal end of the single IV spike; and

inserting an IV port spike of an infusion set into an IV port of the liquid transfer device, the IV port of the liquid transfer device being fluidly connected to a second IV spike lumen of the single IV spike, wherein the second IV spike lumen is fluidly connected at a proximal end thereof with only the IV port and having a second peripherally disposed distal aperture proximate the distal end of the single IV spike, thereby fluidly connecting the infusion set with the infusion liquid container for administration of the medicated infusion liquid to a patient.

10. The method of claim 9,

wherein the first IV spike lumen extends further distally than the second IV spike lumen, whereby the first peripherally disposed distal aperture is distally spaced from the second peripherally disposed distal aperture along the single IV spike.

11. A liquid transfer device configured for use with each of an infusion liquid container containing an infusion liquid and having an intravenous administration port for administering the infusion liquid, a vial containing a medicament additive sealed by a vial stopper, and an infusion set including an IV port spike and a connector for administration purposes to a patient,

the liquid transfer device comprising:

a monolithic trifurcated connector body defining a barrel at a first end thereof, a single IV spike at a second end thereof and a vial adapter lumen at a third end thereof;

an IV port connected to the barrel and configured to sealingly receive the IV port spike of the infusion set;

a vial adapter comprising the vial adapter lumen and configured to telescopically mount onto the vial, the vial adapter including a vial spike fluidly connected with the vial adapter lumen and configured to puncture the vial stopper upon mounting of the vial adapter onto the vial for flow communication therewith,

the single IV spike comprising an IV spike lumen and being configured to sealingly insert into the intravenous administration port of the infusion liquid container, and

a plunger including a plunger tube defining a plunger tube lumen therein, wherein the barrel defines an internal chamber fluidly connected with the IV spike lumen and sealingly and slidably receiving the plunger tube,

wherein plunger tube is fluidly connected with the IV port via a proximal end thereof and the plunger tube includes a check valve at a distal end thereof, whereby the IV port is fluidly connected with the second IV spike lumen in an open position of the check valve and fluidly disconnected from the second IV spike lumen in a closed position of the check valve.

12. The liquid transfer device of claim 11,

further comprising a flow control valve configured to selectively fluidly connect the IV spike lumen to the vial adapter lumen or the barrel.

13. The liquid transfer device of claim 11,

wherein the vial adapter is detachable.

14. A liquid transfer device comprising:

a vial adapter configured to receive a vial and including a vial spike, the vial spike being configured to puncture a vial stopper of the vial and defining a vial spike lumen;

an intravenous (IV) port configured to receive a port spike of an infusion set; and

a connector body including:

a vial adapter lumen in fluid communication with the vial spike lumen,
a barrel connected to the IV port, and
an IV spike including a central wall and defining:
 a first IV spike lumen in fluid communication with the vial adapter lumen
and having a distal-facing aperture, and
 a second IV spike lumen in fluid communication with the IV port and
having a side-facing aperture,
 wherein the first IV spike lumen and the second IV spike lumen are
separated by the central wall.

15. The liquid transfer device of claim 14, wherein the distal-facing aperture is aligned with a longitudinal axis of the first IV spike lumen.

16. The liquid transfer device of claim 14, wherein the IV spike has a tapered distal tip, and the distal-facing aperture extends through the tapered distal tip.

17. The liquid transfer device of claim 14, wherein the side-facing aperture is lateral of a longitudinal axis of the second IV spike lumen.

18. The liquid transfer device of claim 14, wherein the central wall has a transverse protrusion forming a distal surface of the second IV spike lumen.

19. The liquid transfer device of claim 14, wherein the vial adapter includes a skirt configured to telescopically receive the vial, and the skirt includes at least two inwardly directed protrusions for snap-fitting under a flange of the vial.

20. The liquid transfer device of claim 14, wherein the IV port includes:
 a connecting member having an internal lumen and a septum configured to be punctured by the port spike of the infusion set; and
 a twist-off member frangibly attached to the connecting member and configured to be removed from the connecting member without leading to flow communication beyond the septum.

21. The liquid transfer device of claim 14, wherein the barrel is aligned with a longitudinal axis of the IV spike, and the vial adapter lumen is angularly disposed relative to the longitudinal axis of the IV spike.

22. The liquid transfer device of claim 14, wherein the connector body has a flange at a proximal end of the IV spike.

23. A liquid transfer device comprising:

a vial adapter configured to receive a vial and including a vial spike, the vial spike being configured to puncture a vial stopper of the vial and defining a vial spike lumen;

an intravenous (IV) port configured to receive a port spike of an infusion set; and
a connector body including:

a vial adapter lumen in fluid communication with the vial spike lumen,

a barrel connected to the IV port, and

an IV spike including a central wall and defining:

a first IV spike lumen in fluid communication with the vial adapter lumen and having a first aperture aligned with a longitudinal axis of the first IV spike lumen, and

a second IV spike lumen in fluid communication with the IV port and having a second aperture lateral of a longitudinal axis of the second IV spike lumen,

wherein the first IV spike lumen and the second IV spike lumen are separated by the central wall.

24. The liquid transfer device of claim 23, wherein the first aperture is distal-facing and the second aperture is side-facing.

25. The liquid transfer device of claim 23, wherein the IV spike has a tapered distal tip, and the second aperture extends through the tapered distal tip.

26. The liquid transfer device of claim 23, wherein the central wall has a transverse protrusion forming a distal surface of the second IV spike lumen.

27. The liquid transfer device of claim 23, wherein the vial adapter includes a skirt configured to telescopically receive the vial, and the skirt includes at least two inwardly directed protrusions for snap-fitting under a flange of the vial.

28. The liquid transfer device of claim 23, wherein the IV port includes:
a connecting member having an internal lumen and a septum configured to be punctured by the port spike of the infusion set; and
a twist-off member frangibly attached to the connecting member and configured to be removed from the connecting member without leading to flow communication beyond the septum.

29. The liquid transfer device of claim 23, wherein the barrel is aligned with a longitudinal axis of the IV spike, and the vial adapter lumen is angularly disposed relative to the longitudinal axis of the IV spike.

30. The liquid transfer device of claim 23, wherein the connector body has a flange at a proximal end of the IV spike.

31. A liquid transfer device comprising:
a vial adapter configured to receive a vial and including a vial spike, the vial spike being configured to puncture a vial stopper of the vial and defining a vial spike lumen;
an intravenous (IV) port configured to receive a port spike of an infusion set; and
a connector body including:
a vial adapter lumen in fluid communication with the vial spike lumen,
a barrel connected to the IV port, and
an IV spike including a central wall and defining:
a first IV spike lumen being straight and in fluid communication with the vial adapter lumen and, and
a second IV spike lumen being L-shaped and in fluid communication with the IV port,
wherein the first IV spike lumen and the second IV spike lumen are separated by the central wall, and the central wall has a transverse protrusion forming a distal surface of the second IV spike lumen.

32. The liquid transfer device of claim 31, wherein the first IV spike lumen includes a distal-facing aperture aligned with a longitudinal axis of the first IV spike lumen.

33. The liquid transfer device of claim 31, wherein the second IV spike lumen includes a side-facing aperture lateral of a longitudinal axis of the second IV spike lumen.

34. The liquid transfer device of claim 31, wherein the vial adapter includes a skirt configured to telescopically receive the vial, and the skirt includes at least two inwardly directed protrusions for snap-fitting under a flange of the vial.

35. The liquid transfer device of claim 31, wherein the IV port includes:
a connecting member having an internal lumen and a septum configured to be punctured by the port spike of the infusion set; and
a twist-off member frangibly attached to the connecting member and configured to be removed from the connecting member without leading to flow communication beyond the septum.

36. The liquid transfer device of claim 31, wherein the barrel is aligned with a longitudinal axis of the IV spike, and the vial adapter lumen is angularly disposed relative to the longitudinal axis of the IV spike.

37. The liquid transfer device of claim 31, wherein the connector body has a flange at a proximal end of the IV spike.

38. A medicinal vial reconstitution and dispensing apparatus, comprising:
a receptacle including an apron and a vial spike configured to engage a medicinal vial, the vial spike being configured to penetrate a cap on the medicinal vial;
an intravenous (IV) connector configured for inline connection to a patient IV line; and
a bifurcated body extending from the IV connector and having an IV bag spike with a tapered end, the bifurcated body enclosing a first channel and a second channel,
wherein the first channel is configured for fluid communication from the receptacle to an IV bag via a first orifice on the IV bag spike, the second channel is configured for transferring liquids from the IV bag to the IV connector via a second orifice on the IV bag spike, at least one

of the first orifice and the second orifice is on a side of the IV bag spike, and the first orifice and the second orifice define respective fluidic connections to the receptacle and the patient IV line.

39. The apparatus of claim 38, wherein the first orifice extends through the tapered end, and the second orifice is on the side of the IV bag spike.

40. The apparatus of claim 38, wherein the first orifice is aligned with a longitudinal axis of the first channel.

41. The apparatus of claim 38, wherein the second orifice is lateral of a longitudinal axis of the second channel.

42. The apparatus of claim 38, wherein the IV connector includes:
a connecting member having an internal lumen and a septum configured to be punctured by a port spike of the patient IV line; and
a twist-off member frangibly attached to the connecting member and configured to be removed from the connecting member without leading to flow communication beyond the septum.

43. The apparatus of claim 38, wherein the bifurcated body has a flange at a proximal end of the IV bag spike.

44. A liquid transfer device comprising:
a vial adapter configured to receive a vial and including a vial spike, the vial spike being configured to puncture a vial stopper of the vial and defining a vial spike lumen;
an intravenous (IV) port configured to receive a port spike of an infusion set; and
a connector body including:
a vial adapter lumen in fluid communication with the vial spike lumen,
a barrel connected to the IV port, and
an IV spike including a central wall and defining:
a first IV spike lumen in fluid communication with the vial adapter lumen
and having a first aperture, and

a second IV spike lumen in fluid communication with the IV port and having a second aperture lateral of a longitudinal axis of the second IV spike lumen,

wherein the first IV spike lumen and the second IV spike lumen are separated by the central wall.

45. The liquid transfer device of claim 44, wherein the first aperture is aligned with a longitudinal axis of the first IV spike lumen.

46. The liquid transfer device of claim 44, wherein the first aperture is distal-facing and the second aperture is side-facing.

47. The liquid transfer device of claim 44, wherein the IV spike has a tapered distal tip, and the second aperture extends through the tapered distal tip.

48. The liquid transfer device of claim 44, wherein the central wall has a transverse protrusion forming a distal surface of the second IV spike lumen.

49. The liquid transfer device of claim 44, wherein the vial adapter includes a skirt configured to telescopically receive the vial, and the skirt includes at least two inwardly directed protrusions for snap-fitting under a flange of the vial.

50. The liquid transfer device of claim 44, wherein the IV port includes:
a connecting member having an internal lumen and a septum configured to be punctured by the port spike of the infusion set; and
a twist-off member frangibly attached to the connecting member and configured to be removed from the connecting member without leading to flow communication beyond the septum.

51. The liquid transfer device of claim 44, wherein the barrel is aligned with a longitudinal axis of the IV spike, and the vial adapter lumen is angularly disposed relative to the longitudinal axis of the IV spike.

52. The liquid transfer device of claim 44, wherein the connector body has a flange at a proximal end of the IV spike.

53. A liquid transfer device comprising:
a vial adapter configured to receive a vial and including a vial spike, the vial spike being configured to puncture a vial stopper of the vial and defining a vial spike lumen;
an intravenous (IV) port configured to receive a port spike of an infusion set; and
a connector body including:
a vial adapter lumen in fluid communication with the vial spike lumen,
a barrel connected to the IV port, and
an IV spike including a central wall and defining:
a first IV spike lumen in fluid communication with the vial adapter lumen,
and
a second IV spike lumen fluidly connected with the IV port,
wherein the first IV spike lumen and the second IV spike lumen are separated by the central wall, and the central wall has a transverse protrusion forming a distal surface of the second IV spike lumen.
54. The liquid transfer device of claim 53, wherein the first IV spike lumen includes a distal-facing aperture aligned with a longitudinal axis of the first IV spike lumen.
55. The liquid transfer device of claim 53, wherein the second IV spike lumen includes a side-facing aperture lateral of a longitudinal axis of the second IV spike lumen.
56. The liquid transfer device of claim 53, wherein the vial adapter includes a skirt configured to telescopically receive the vial, and the skirt includes at least two inwardly directed protrusions for snap-fitting under a flange of the vial.
57. The liquid transfer device of claim 53, wherein the IV port includes:
a connecting member having an internal lumen and a septum configured to be punctured by the port spike of the infusion set; and
a twist-off member frangibly attached to the connecting member and configured to be removed from the connecting member without leading to flow communication beyond the septum.

58. The liquid transfer device of claim 53, wherein the barrel is aligned with a longitudinal axis of the IV spike, and the vial adapter lumen is angularly disposed relative to the longitudinal axis of the IV spike.

59. The liquid transfer device of claim 53, wherein the connector body has a flange at a proximal end of the IV spike.

60. A liquid transfer device comprising:

a vial adapter configured to receive a vial, the vial adapter including a skirt and a vial spike, the skirt being configured to telescopically receive the vial, and the vial spike being configured to puncture a vial stopper of the vial and defining a vial spike lumen;

an intravenous (IV) port configured to receive a port spike of an infusion set, the IV port having an internal lumen and a septum configured to be punctured by the port spike of the infusion set; and

a connector body including:

a vial adapter lumen in fluid communication with the vial spike lumen,

a barrel connected to the IV port, and

an IV spike including a central wall and defining:

a first IV spike lumen in fluid communication with the vial adapter lumen and having a distal-facing aperture aligned with a longitudinal axis of the first IV spike lumen, and

a second IV spike lumen in fluid communication with the IV port and having a side-facing aperture lateral of a longitudinal axis of the second IV spike lumen,

wherein the first IV spike lumen and the second IV spike lumen are separated by the central wall, the central wall has a transverse protrusion forming a distal surface of the second IV spike lumen, the barrel is aligned with a longitudinal axis of the IV spike, and the vial adapter lumen is angularly disposed from the longitudinal axis of the IV spike.

61. The liquid transfer device of claim 60, wherein the IV spike has a tapered distal tip, and the distal-facing aperture extends through the tapered distal tip.

62. The liquid transfer device of claim 60, wherein the skirt includes at least two inwardly directed protrusions for snap-fitting under a flange of the vial.
63. The liquid transfer device of claim 60, wherein the IV port includes:
a connecting member having an internal lumen and a septum configured to be punctured by the port spike of the infusion set; and
a twist-off member frangibly attached to the connecting member and configured to be removed from the connecting member without leading to flow communication beyond the septum.
64. The liquid transfer device of claim 60, wherein the barrel is aligned with a longitudinal axis of the IV spike, and the vial adapter lumen is angularly disposed relative to the longitudinal axis of the IV spike.
65. The liquid transfer device of claim 60, wherein the connector body has a flange at a proximal end of the IV spike.
66. A medicinal vial reconstitution and dispensing apparatus, comprising:
a receptacle including an apron and a spike, the spike adapted to engage a medicinal vial and adapted for penetration of a resilient portion in a cap on the medicinal vial;
an intravenous (IV) connector adapted for inline connection to a patient IV line, the IV connector adapted for transport of medicinal fluids to a patient via the patient IV line; and
a bifurcated junction body having a transfer channel adapted for fluid communication between the receptacle and the IV connector, the bifurcated junction body having:
a flow control element for ensuring a controlled flow path from the transfer channel to a fluid reservoir of an IV fluid bag before passing to the patient IV line through the IV connector, and
an IV bag spike having a tapered end for engaging the IV fluid bag to establish fluid communication between the IV connector and the fluid reservoir, the IV bag spike having at least one of a first orifice and a second orifice on a side of the IV bag spike, the first orifice and the second orifice defining respective fluidic connections to the transfer channel and the patient IV line.

67. The apparatus of claim 66, wherein the first orifice extends through the tapered end, and the second orifice is on the side of the IV bag spike.

68. The apparatus of claim 66, wherein the first orifice is aligned with a longitudinal axis of the first channel.

69. The apparatus of claim 66, wherein the second orifice is lateral of a longitudinal axis of the second channel.

70. The apparatus of claim 66, wherein the IV connector includes:
a connecting member having an internal lumen and a septum configured to be punctured by a port spike of the patient IV line; and
a twist-off member frangibly attached to the connecting member and configured to be removed from the connecting member without leading to flow communication beyond the septum.

71. The apparatus of claim 66, wherein the bifurcated body has a flange at a proximal end of the IV bag spike.

fluid communication between the vial adapter and the IV spike from fluid communication between the IV port and the IV spike while enabling initial introduction of the medicament additive from the vial to the infusion liquid container through the vial adapter and the first IV spike lumen for mixing with the infusion liquid to form a medicated infusion liquid, and enabling subsequent administration of the medicated infusion liquid to the patient from the infusion liquid container through the second IV spike lumen and the IV port to the infusion set,
wherein the first IV spike lumen extends further distally than the second IV spike lumen, the first peripherally disposed distal aperture and the second peripherally disposed distal aperture are non-overlapping longitudinally, and the first peripherally disposed distal aperture is distally separated from the second peripherally disposed distal aperture by at least about 1.0 mm.

72. A liquid transfer device configured for use with each of an infusion liquid container containing an infusion liquid and having an intravenous administration port for administering the infusion liquid, a vial containing a medicament additive sealed by a vial stopper, and an infusion

set including an IV port spike and a connector for administration purposes to a patient, the liquid transfer device comprising:

a monolithic trifurcated connector body defining a barrel at a first end thereof, an IV spike at a second end thereof and a vial adapter lumen at a third end thereof;

an IV port connected to the barrel and configured to sealingly receive the IV port spike of the infusion set; and

a vial adapter configured to telescopically mount onto the vial, the vial adapter including a vial spike fluidly connected with the vial adapter lumen and configured to puncture the vial stopper upon mounting of the vial adapter onto the vial for flow communication therewith,

the IV spike being configured to sealingly insert into the intravenous administration port of the infusion liquid container, and the IV spike having:

a first IV spike lumen fluidly connected at a proximal end thereof with the vial adapter lumen via the monolithic trifurcated connector body, the first IV spike lumen having a first peripherally disposed distal aperture; and

a second IV spike lumen fluidly connected at a proximal end thereof with the IV port via the monolithic trifurcated connector body, the second IV spike lumen having a second peripherally disposed distal aperture,

thereby separating fluid communication between the vial adapter and the IV spike from fluid communication between the IV port and the IV spike while enabling initial introduction of the medicament additive from the vial to the infusion liquid container through the vial adapter and the first IV spike lumen for mixing with the infusion liquid to form a medicated infusion liquid, and enabling subsequent administration of the medicated infusion liquid to the patient from the infusion liquid container through the second IV spike lumen and the IV port to the infusion set,

wherein the first IV spike lumen extends further distally than the second IV spike lumen, the first peripherally disposed distal aperture and the second peripherally disposed distal aperture are non-overlapping longitudinally, and the first peripherally disposed distal aperture is distally separated from the second peripherally disposed distal aperture by at least about 1.0 mm.

73. The liquid transfer device of claim 72, wherein the first IV spike lumen is directly and continuously fluidly connected with the vial adapter lumen and the infusion liquid container.

74. The liquid transfer device of claim 73, wherein the second IV spike lumen is directly and continuously fluidly connected with the IV port and the infusion liquid container.

75. The liquid transfer device of claim 72, wherein the IV port is permanently secured to the barrel.

76. The liquid transfer device of claim 72, further comprising a plunger including a plunger tube defining a plunger tube lumen therein,

wherein the barrel defines an internal chamber fluidly connected with the second IV spike lumen and sealingly and slidably receiving the plunger tube.

77. The liquid transfer device of claim 76, wherein the plunger tube is fluidly connected with the IV port via a proximal end thereof and the plunger tube includes a check valve at a distal end thereof, whereby the IV port is fluidly connected with the second IV spike lumen in an open position of the check valve and fluidly disconnected from the second IV spike lumen in a closed position of the check valve.

78. The liquid transfer device of claim 76, wherein the first IV spike lumen and the second IV spike lumen extend parallel to one another.

79. The liquid transfer device of claim 72, wherein the IV spike has a flat surface distal of the second peripherally disposed distal aperture.

80. A method of using a liquid transfer device having a monolithic trifurcated connector body defining a barrel at a first end thereof, a single intravenous (IV) spike at a second end thereof and a vial adapter lumen at a third end thereof, the method comprising:

mounting a vial adapter comprising the vial adapter lumen onto a vial containing a medicament additive, and piercing a stopper of the vial with a vial spike of the vial adapter fluidly connected with the vial adapter lumen;

piercing an administration port of an infusion liquid container containing an infusion liquid with the IV spike;

adding the medicament additive within the vial to the infusion liquid within the infusion liquid container to obtain a medicated infusion liquid via the vial adapter lumen and a first IV spike lumen of the IV spike, the first IV spike lumen being fluidly connected at a proximal end

thereof with the vial adapter lumen and having a first peripherally disposed distal aperture proximate a distal end of the IV spike; and

inserting an IV port spike of an infusion set into an IV port of the liquid transfer device, the IV port of the liquid transfer device being fluidly connected to a second IV spike lumen of the IV spike, wherein the second IV spike lumen is fluidly connected at a proximal end thereof with the IV port and having a second peripherally disposed distal aperture proximate the distal end of the IV spike, thereby fluidly connecting the infusion set with the infusion liquid container for administration of the medicated infusion liquid to a patient, and wherein the first IV spike lumen extends further distally than the second IV spike lumen, the first peripherally disposed distal aperture and the second peripherally disposed distal aperture are non-overlapping longitudinally, and the first peripherally disposed distal aperture is distally separated from the second peripherally disposed distal aperture by at least about 1.0 mm.

81. The method of claim 80, wherein the first IV spike lumen extends further distally than the second IV spike lumen, whereby the first peripherally disposed distal aperture is distally spaced from the second peripherally disposed distal aperture along the IV spike.

82. A liquid transfer device configured for use with each of an infusion liquid container containing an infusion liquid and having an intravenous administration port for administering the infusion liquid, a vial containing a medicament additive sealed by a vial stopper, and an infusion set including an IV port spike and a connector for administration purposes to a patient,

the liquid transfer device comprising:

a monolithic trifurcated connector body defining a barrel at a first end thereof, an IV spike at a second end thereof and a vial adapter lumen at a third end thereof;

an IV port connected to the barrel and configured to sealingly receive the IV port spike of the infusion set;

a vial adapter comprising the vial adapter lumen and configured to telescopically mount onto the vial, the vial adapter including a vial spike fluidly connected with the vial adapter lumen and configured to puncture the vial stopper upon mounting of the vial adapter onto the vial for flow communication therewith,

the IV spike comprising an IV spike lumen and being configured to sealingly insert into the intravenous administration port of the infusion liquid container; and

a plunger including a plunger tube defining a plunger tube lumen therein, wherein the barrel defines an internal chamber fluidly connected with the IV spike lumen and sealingly and slidably receiving the plunger tube,

wherein the plunger tube is fluidly connected with the IV port via a proximal end thereof, and the plunger tube includes a check valve at a distal end thereof, whereby the IV port is fluidly connected with the IV spike lumen in an open position of the check valve and fluidly disconnected from the IV spike lumen in a closed position of the check valve.

83. The liquid transfer device of claim 82, further comprising a flow control valve configured to selectively fluidly connect the IV spike lumen to the vial adapter lumen or the barrel.

84. The liquid transfer device of claim 82, wherein the valve is a check valve.

85. The liquid transfer device of claim 82, wherein the vial adapter is detachable.

86. A liquid transfer device configured for use with each of an infusion liquid container containing an infusion liquid and having an intravenous administration port for administering the infusion liquid, a vial containing a medicament additive sealed by a vial stopper, and an infusion set including an IV port spike and a connector for administration purposes to a patient, the liquid transfer device comprising:

a monolithic trifurcated connector body defining a barrel at a first end thereof, an IV spike at a second end thereof and a vial adapter lumen at a third end thereof;

an IV port connected to the barrel and configured to sealingly receive the IV port spike of the infusion set;

a vial adapter configured to telescopically mount onto the vial, the vial adapter including a vial spike fluidly connected with the vial adapter lumen and configured to puncture the vial stopper upon mounting of the vial adapter onto the vial for flow communication therewith,

the IV spike being configured to sealingly insert into the intravenous administration port of the infusion liquid container, and the IV spike having:

a first IV spike lumen fluidly connected at a proximal end thereof with the vial adapter lumen via the monolithic trifurcated connector body, the first IV spike lumen having a first peripherally disposed distal aperture; and

a second IV spike lumen fluidly connected at a proximal end thereof with the IV port via the monolithic trifurcated connector body, the second IV spike lumen having a second peripherally disposed distal aperture,

thereby separating fluid communication between the vial adapter and the IV spike from fluid communication between the IV port and the IV spike while enabling initial introduction of the medicament additive from the vial to the infusion liquid container through the vial adapter and the first IV spike lumen for mixing with the infusion liquid to form a medicated infusion liquid, and enabling subsequent administration of the medicated infusion liquid to the patient from the infusion liquid container through the second IV spike lumen and the IV port to the infusion set; and
a plunger including a plunger tube defining a plunger tube lumen therein,
wherein the barrel defines an internal chamber fluidly connected with the second IV spike lumen and sealingly and slidably receiving the plunger tube.

87. The liquid transfer device of claim 86, wherein the plunger tube is fluidly connected with the IV port via a proximal end thereof, and the plunger tube includes a check valve at a distal end thereof, whereby the IV port is fluidly connected with the second IV spike lumen in an open position of the check valve and fluidly disconnected from the second IV spike lumen in a closed position of the check valve.

88. The liquid transfer device of claim 86, wherein the first IV spike lumen and the second IV spike lumen extend parallel to one another.

89. The liquid transfer device of claim 86, wherein the vial adapter is detachable.

90. A liquid transfer device comprising:

a barrel configured to fluidly connect to an infusion set;
a vial adapter in communication with a vial adapter lumen and having a vial spike, the vial spike being configured to puncture a stopper of a vial containing a medicament, and the vial adapter being configured to receive the vial; and

an intravenous (IV) spike configured to be sealingly inserted into an intravenous administration port of a container of an infusion liquid, the IV spike having a first IV spike

lumen fluidly connected to the vial adapter lumen, and a second IV spike lumen fluidly connected to the infusion set,

wherein the liquid transfer device defines a first fluid path and a second fluid path, the first fluid path is through the vial adapter lumen and the first IV spike lumen to introduce medicament from the vial to the container for mixing with the infusion liquid to form a medicated infusion liquid, and the second fluid path is through the second IV spike lumen to pass the medicated infusion liquid from the container to the infusion set.

91. The liquid transfer device of claim 90, comprising a monolithic trifurcated connector body including at least one of the barrel, the vial adapter, and/or the IV spike.

92. The liquid transfer device of claim 90, wherein the first IV spike lumen has a first peripherally disposed distal aperture, the second IV spike lumen has a second peripherally disposed distal aperture, and the first peripherally disposed distal aperture is distal of the second peripherally disposed distal aperture along the IV spike.

93. The liquid transfer device of claim 90, wherein the barrel is connected to an IV port configured to sealingly receive a port spike of the infusion set to connect to the infusion set.

94. The liquid transfer device of claim 93, wherein the IV port is integrally formed or permanently secured to the barrel.

95. The liquid transfer device of claim 93, wherein the IV port includes a septum configured to be punctured by the port spike of the infusion set.

96. The liquid transfer device of claim 95, wherein the IV port includes a removable member proximal of the septum.

97. The liquid transfer device of claim 90, wherein the first IV spike lumen and the second IV spike lumen extend parallel to one another.

98. The liquid transfer device of claim 90, further comprising a flat surface distal of the second IV spike lumen.

99. The liquid transfer device of claim 90, wherein the vial adapter has a flexible and/or flared skirt.
100. The liquid transfer device of claim 90, wherein the vial adapter is configured to snap onto the vial.
101. The liquid transfer device of claim 90, further comprising a valve in the first fluid path or the second fluid path.
102. The liquid transfer device of claim 101, further comprising an IV port fluidly connected with the second IV spike lumen with the valve in an open position and fluidly disconnected from the second IV spike lumen with the valve in a closed position.
103. The liquid transfer device of claim 90, wherein the barrel is aligned with the IV spike, and the vial adapter angularly bifurcated from the IV spike.
104. The liquid transfer device of claim 90, wherein the vial spike is integral to the vial adapter.

1/14

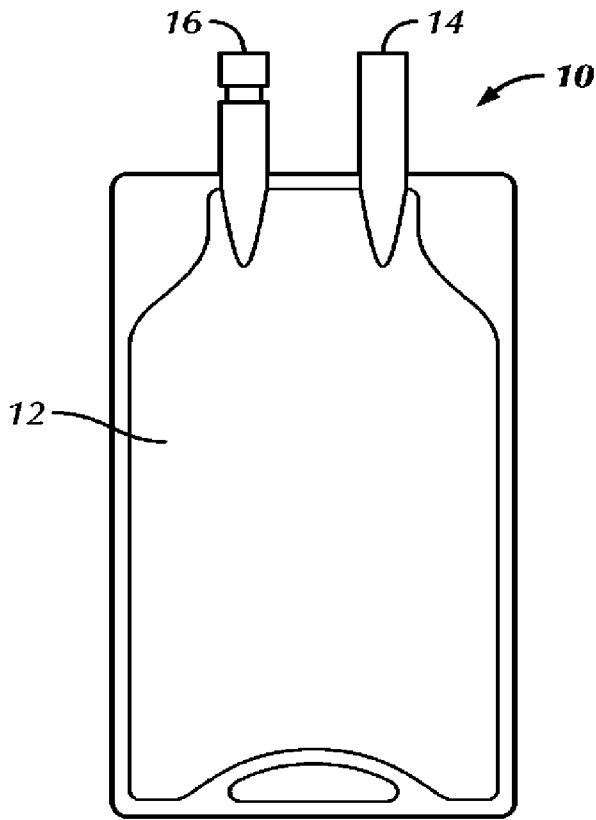

FIG. 1A

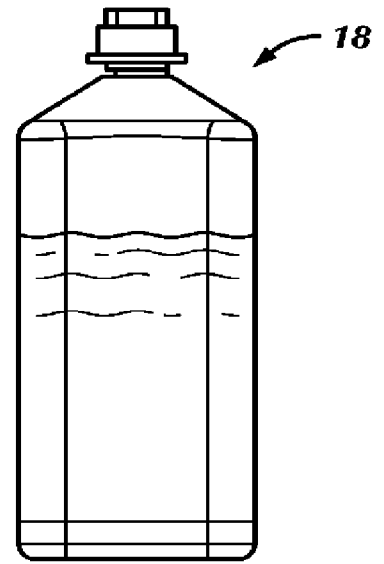

FIG. 1B

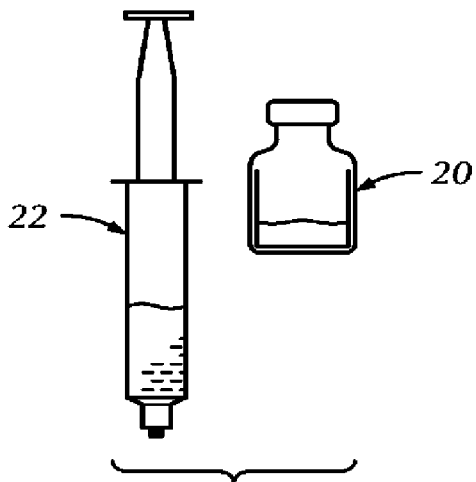

FIG. 1C

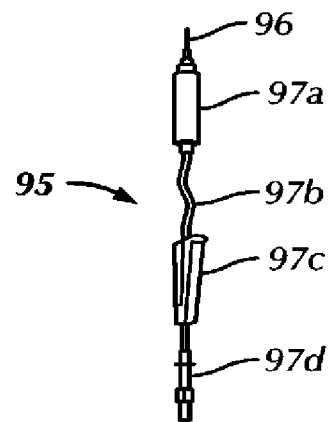
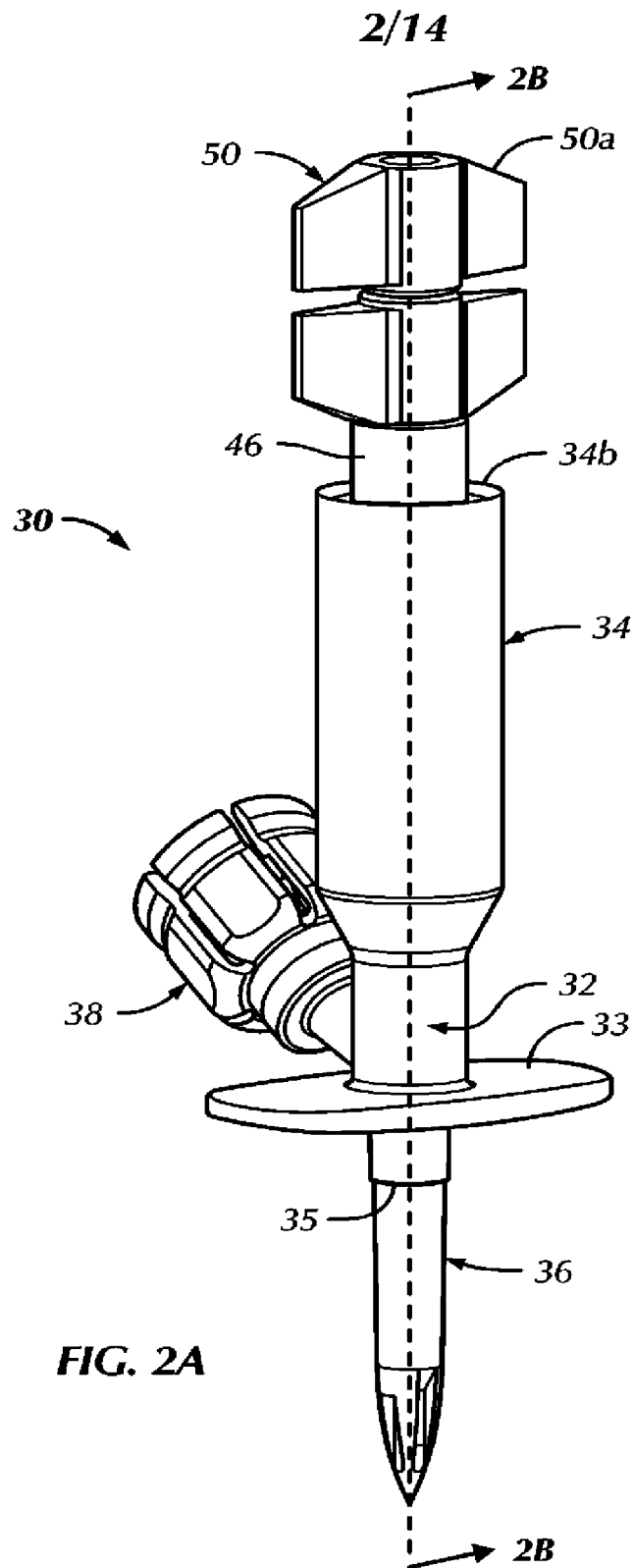
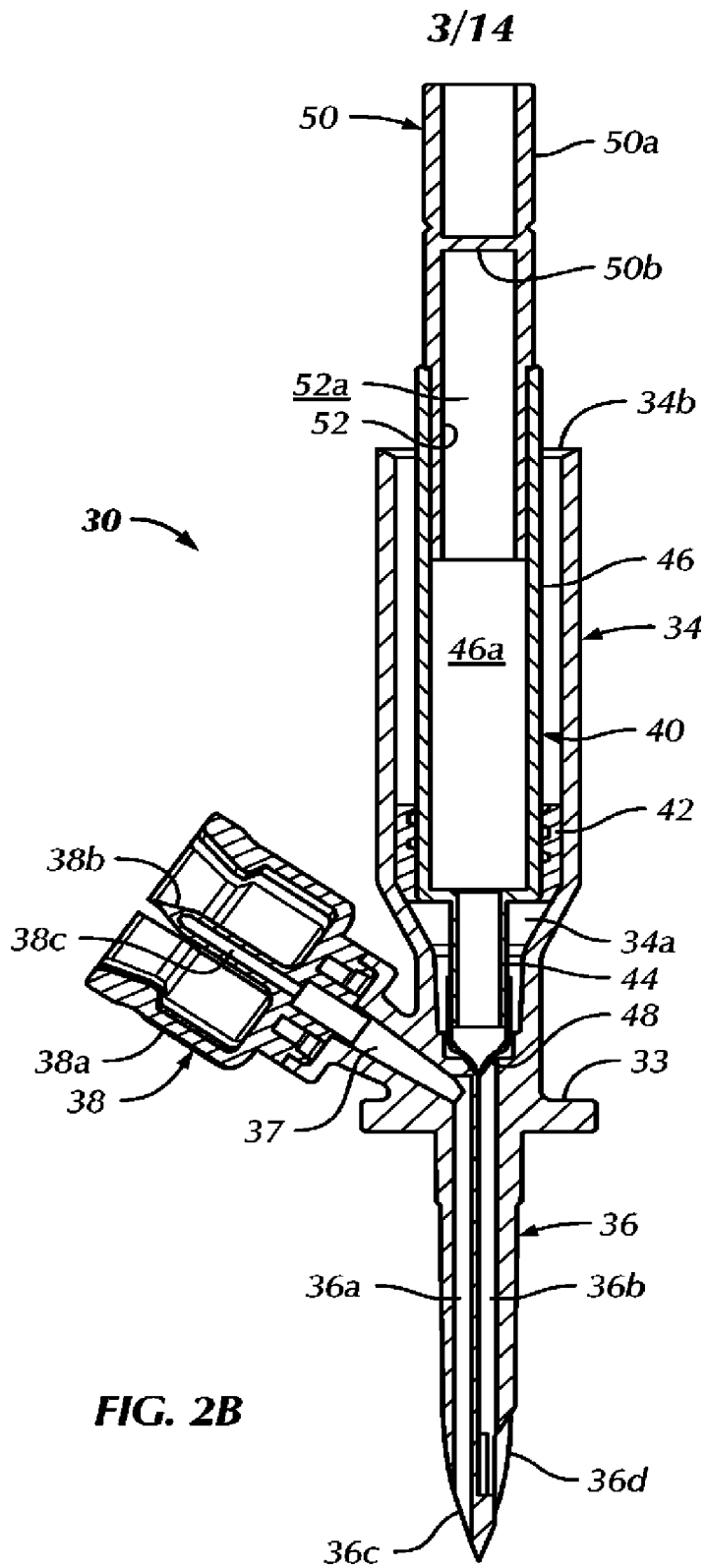

FIG. 1D





4/14

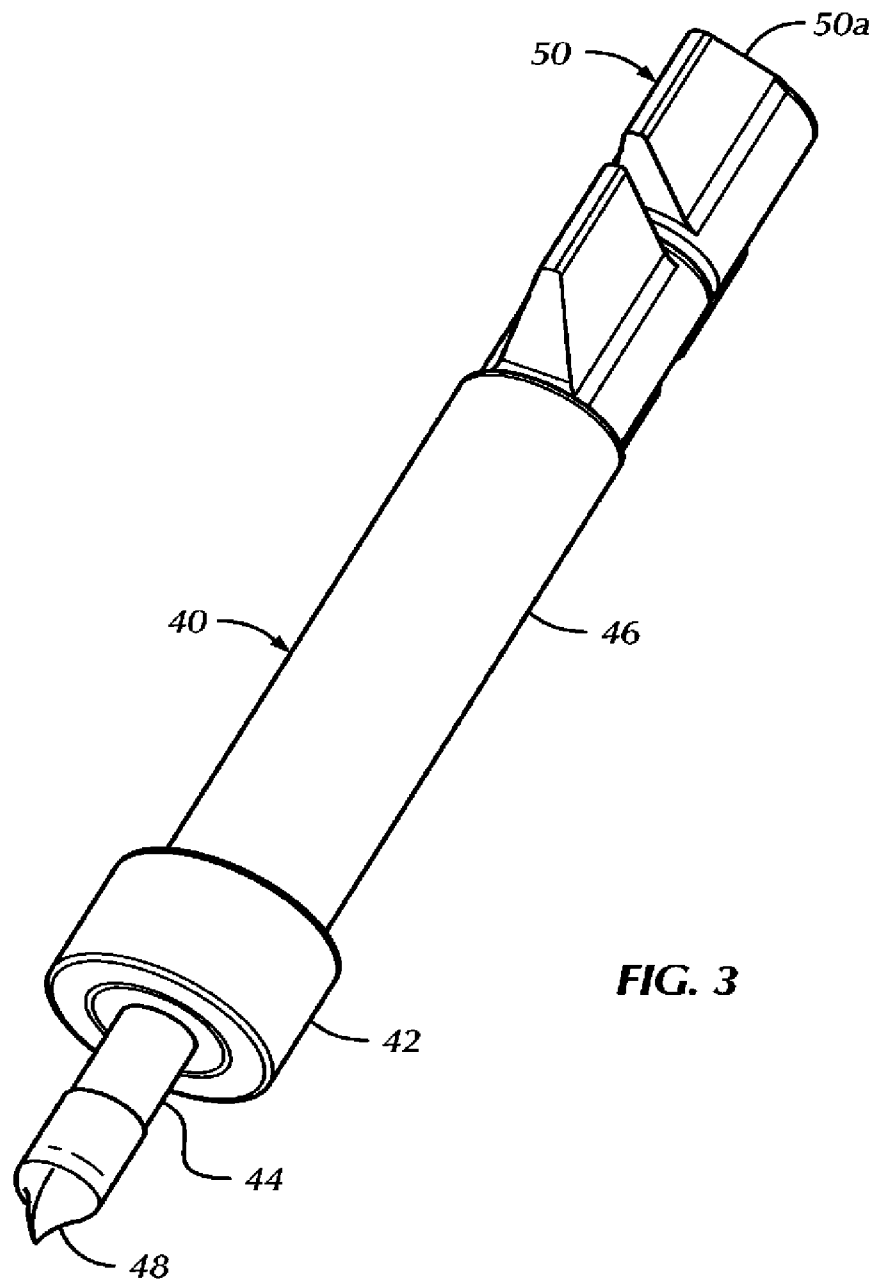

FIG. 3

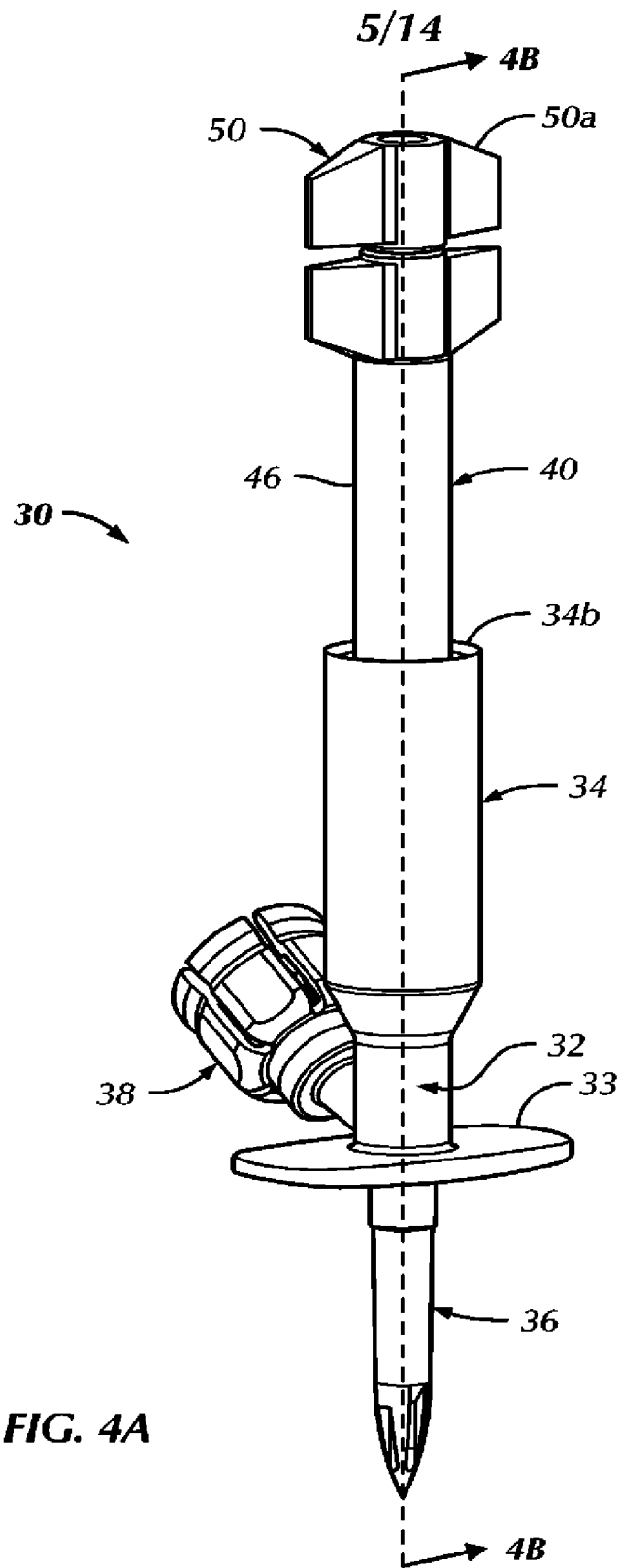
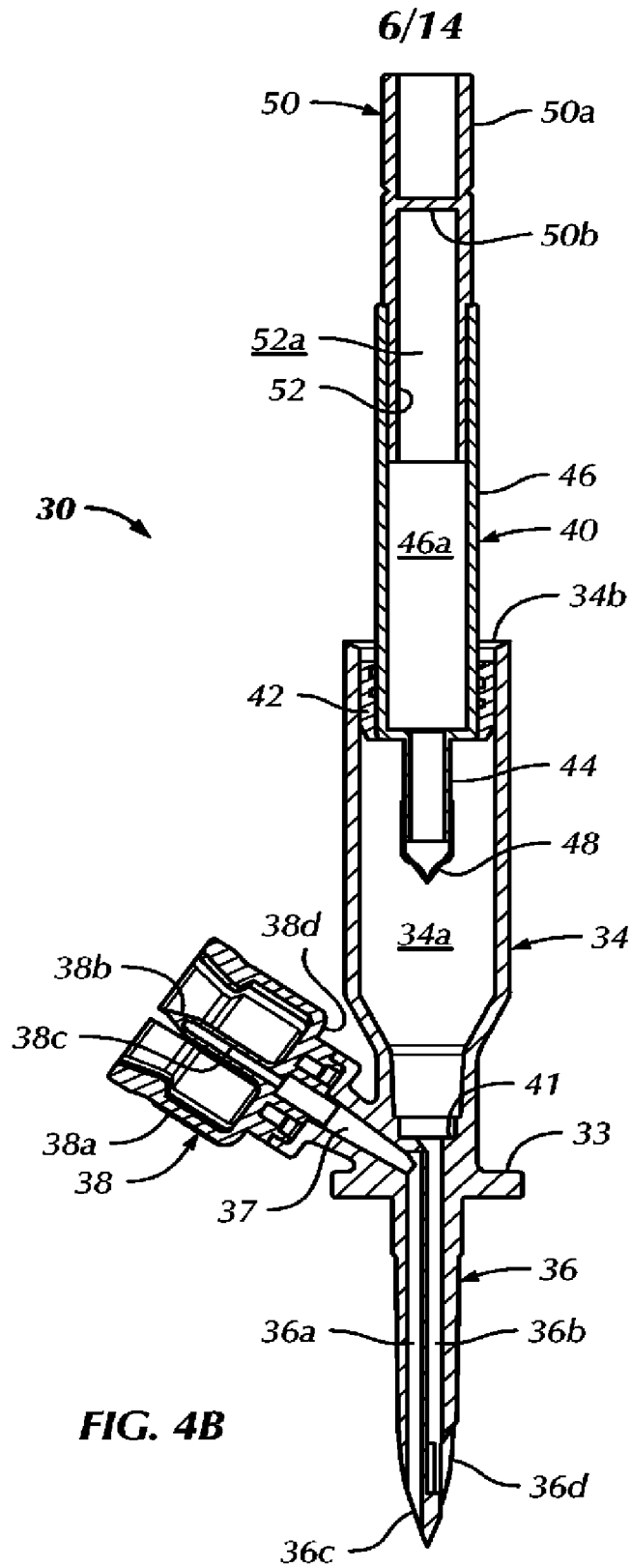
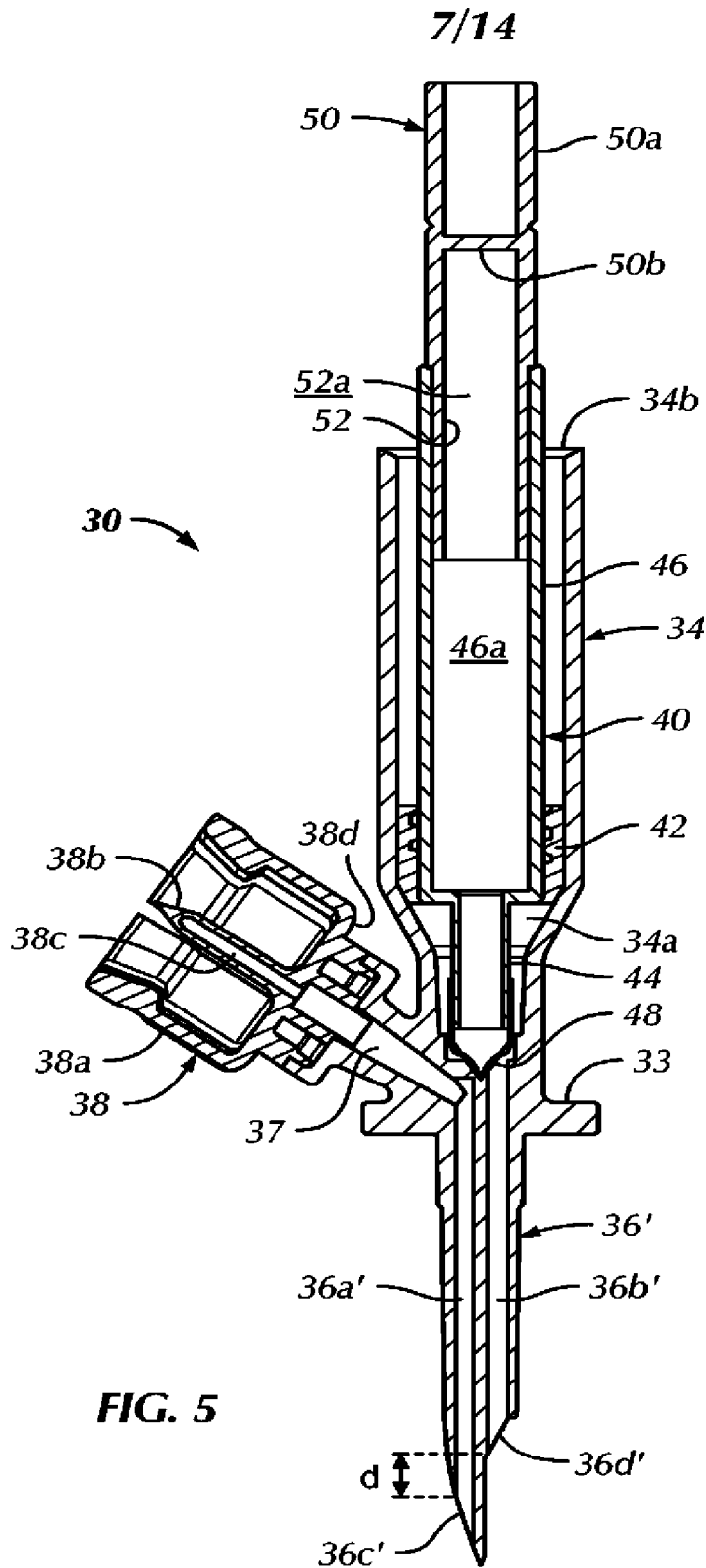

FIG. 4A





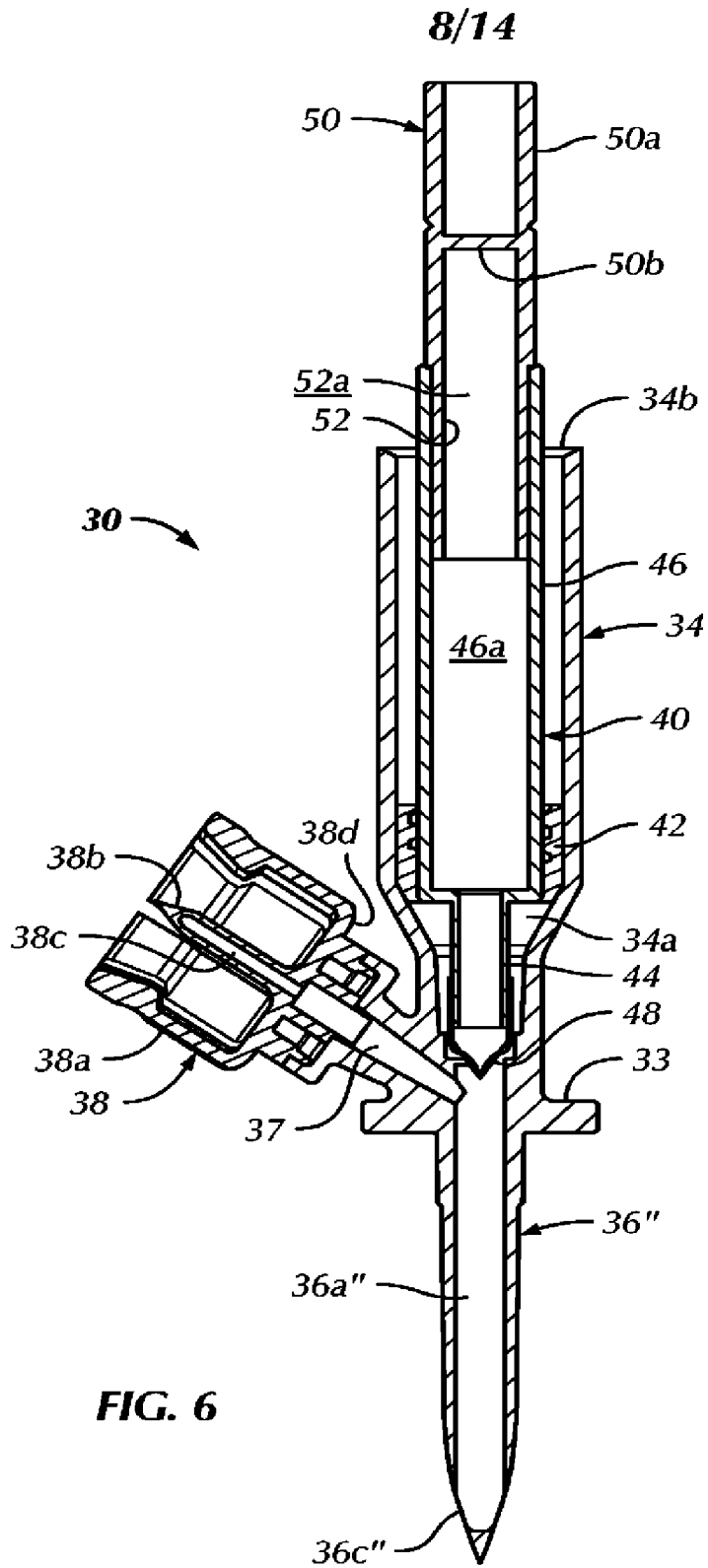

FIG. 6

9/14

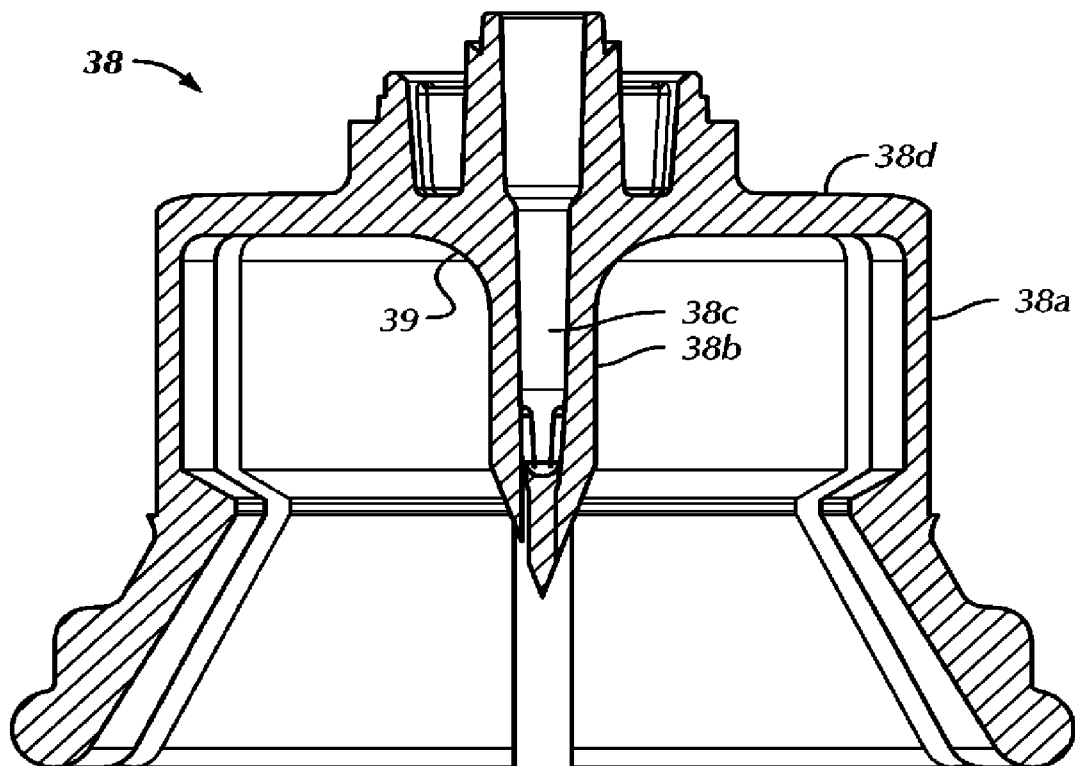

FIG. 7A

10/14

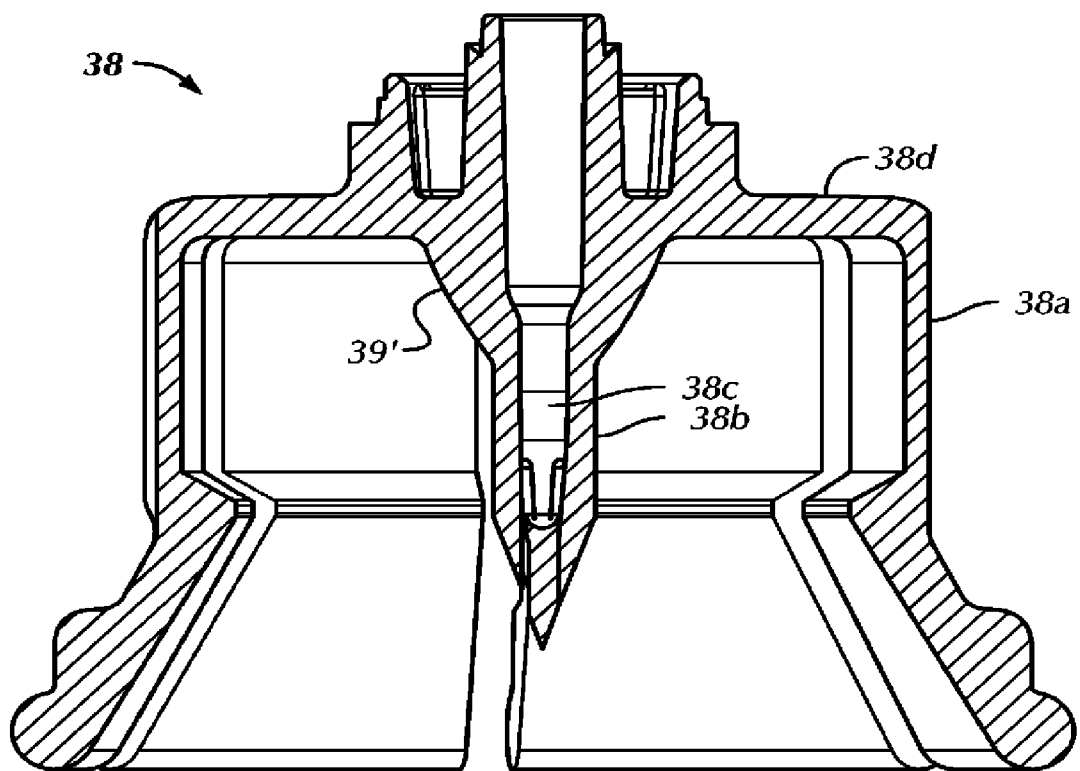

FIG. 7B

11/14

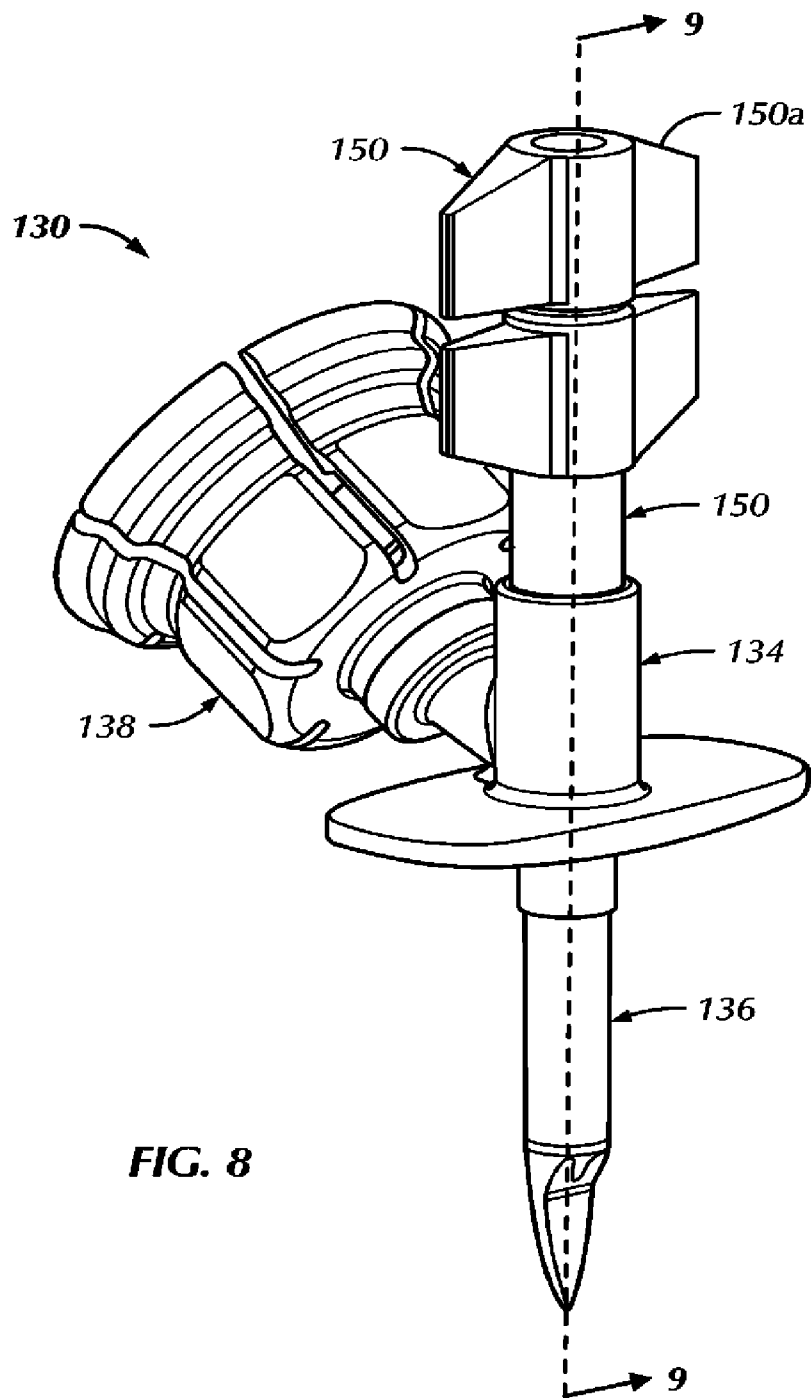

FIG. 8

12/14

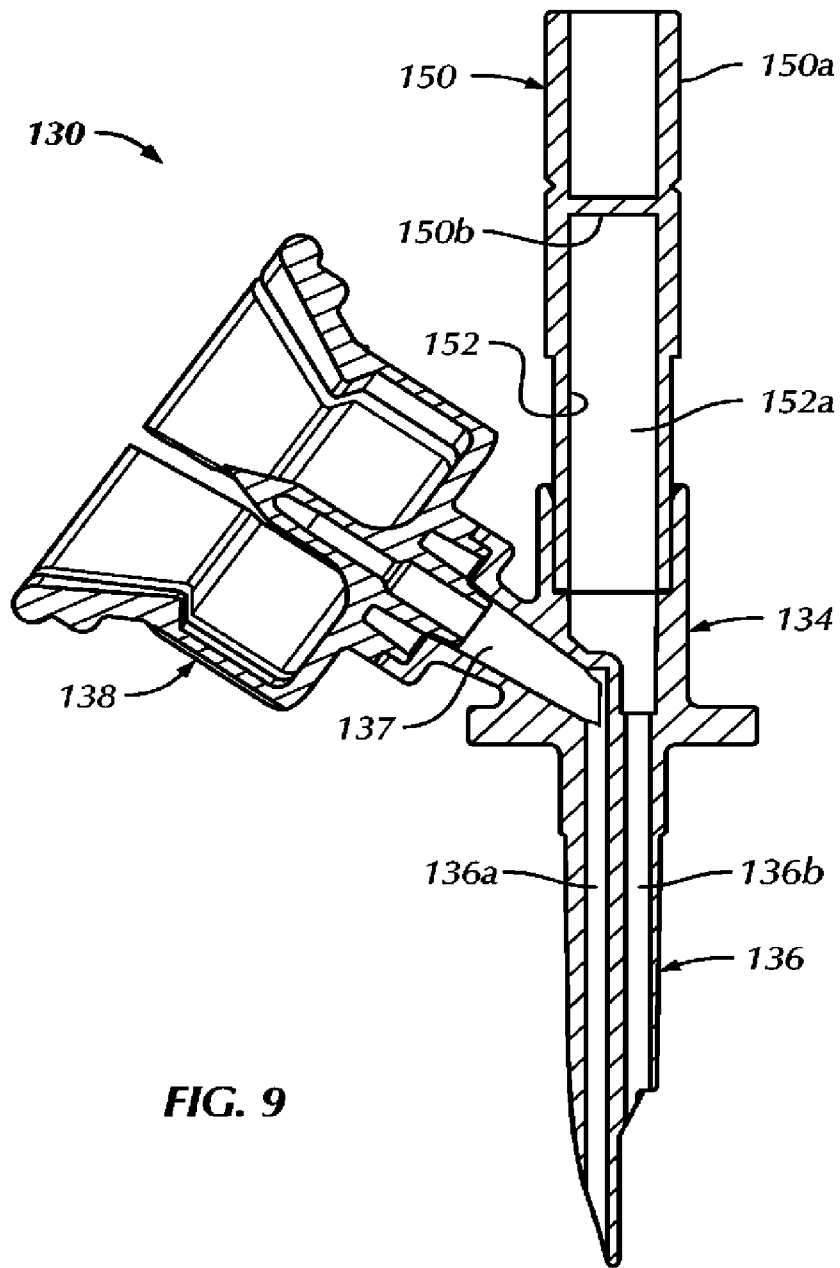

FIG. 9

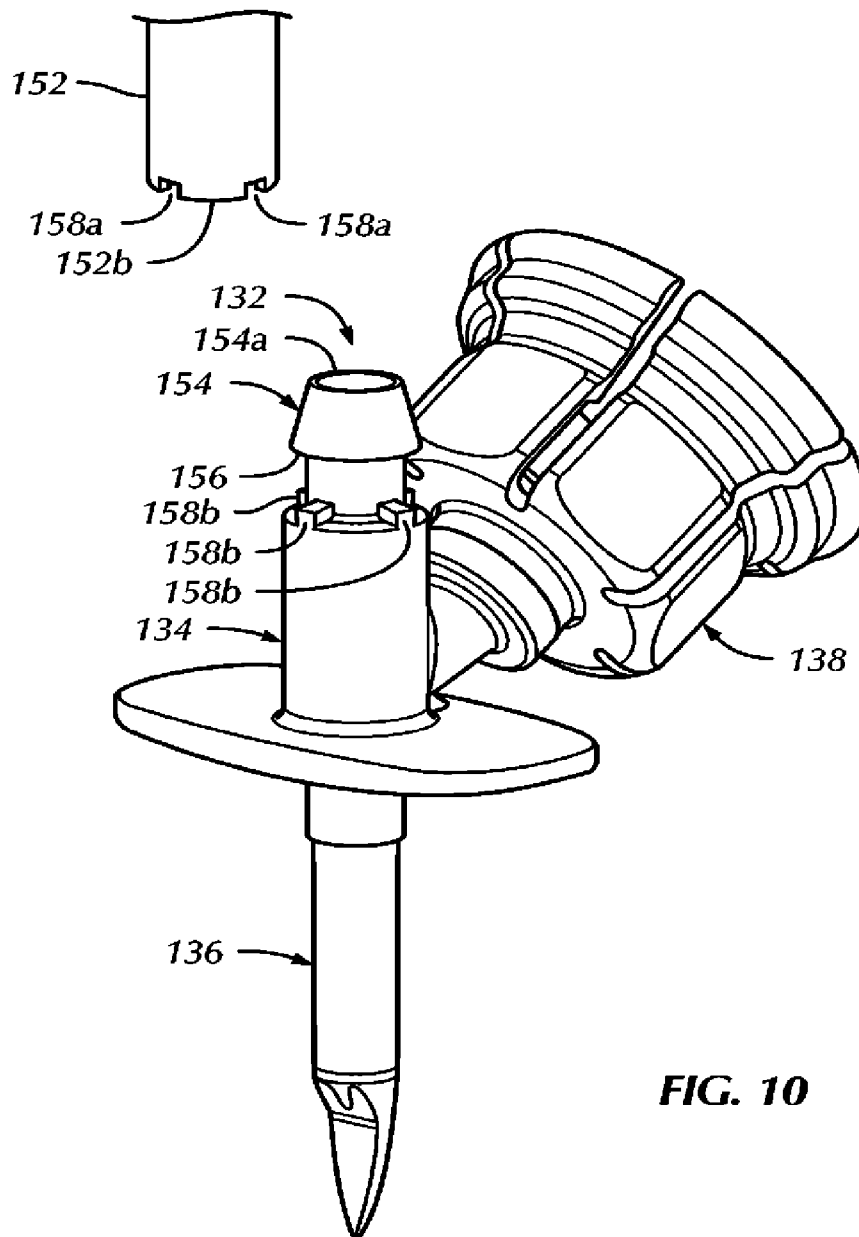

FIG. 10

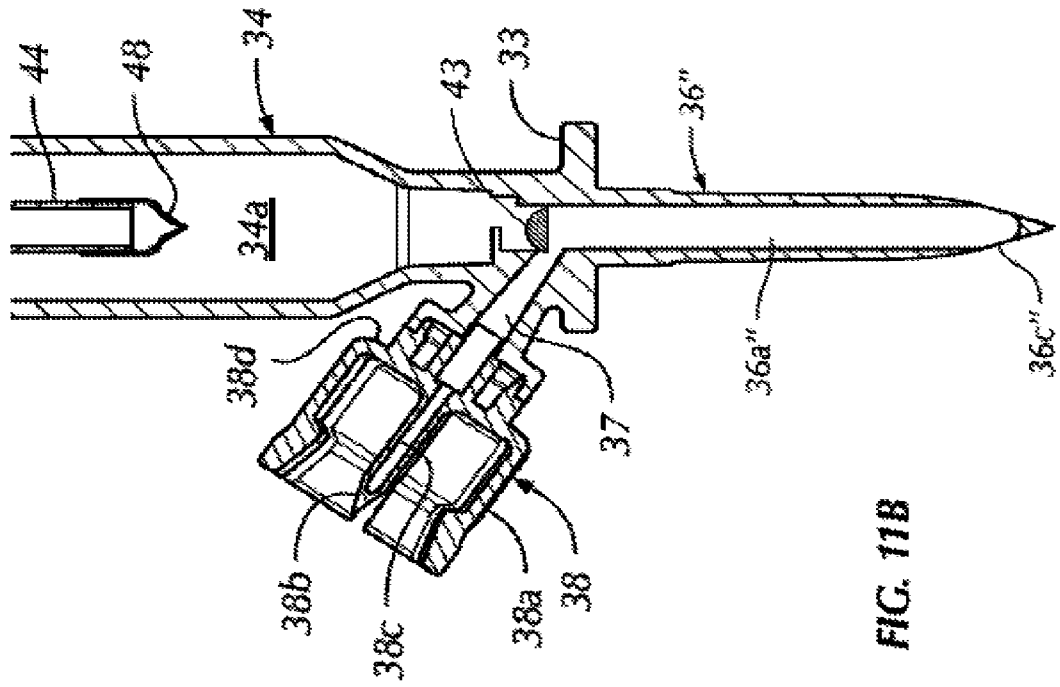

FIG. 11B

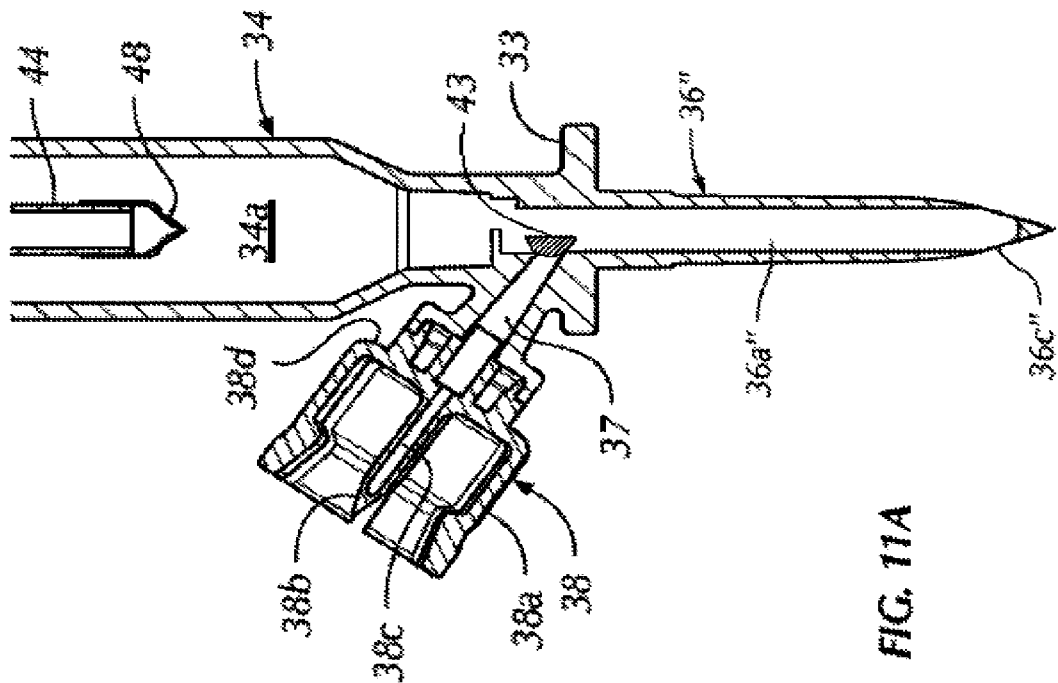

FIG. 11A

