



(86) Date de dépôt PCT/PCT Filing Date: 2005/01/03
(87) Date publication PCT/PCT Publication Date: 2005/07/28
(85) Entrée phase nationale/National Entry: 2006/06/27
(86) N° demande PCT/PCT Application No.: US 2005/000059
(87) N° publication PCT/PCT Publication No.: 2005/067660
(30) Priorité/Priority: 2004/01/06 (US10/752,435)

(51) Cl.Int./Int.Cl. *A61F 2/82* (2006.01),
A61F 2/84 (2006.01), *A61F 2/90* (2006.01)
(71) Demandeur/Applicant:
APTUS ENDOSYSTEMS, INC., US
(72) Inventeurs/Inventors:
BOLDUC, LEE, US;
PARODI, JUAN, US
(74) Agent: SMART & BIGGAR

(54) Titre : SYSTEMES ET METHODES DE PROTHESE DIMENSIONNEE ET CONFIGUREE POUR RECEVOIR ET
RETENIR DES FIXATIONS
(54) Title: PROSTHESIS SYSTEMS AND METHODS SIZED AND CONFIGURED FOR THE RECEIPT AND RETENTION
OF FASTENERS

(57) **Abrégé/Abstract:**

Systems and methods introduce and deploy prosthesis into a blood vessel or hollow body organ. The prosthesis is secured in place by fasteners, and includes a region or regions specially sized and configured to receive and retain the fasteners.



(12) INTERNATIONAL APPLICATION PUBLISHED UNDER THE PATENT COOPERATION TREATY (PCT)

(19) World Intellectual Property
Organization
International Bureau



(43) International Publication Date
28 July 2005 (28.07.2005)

PCT

(10) International Publication Number
WO 2005/067660 A2

- (51) International Patent Classification: Not classified
- (21) International Application Number: PCT/US2005/000059
- (22) International Filing Date: 3 January 2005 (03.01.2005)
- (25) Filing Language: English
- (26) Publication Language: English
- (30) Priority Data: 10/752,435 6 January 2004 (06.01.2004) US
- (71) Applicant (for all designated States except US): **APTUS ENDOSYSTEMS, INC.** [US/US]; 777 N. Pastoria Avenue, Sunnyvale, CA 94085 (US).
- (72) Inventors; and
- (75) Inventors/Applicants (for US only): **BOLDUC, Lee** [US/US]; 716 Grape Avenue, Sunnyvale, CA 94087 (US). **PARODI, Juan** [AR/US]; 1 Barnes-Jewish Hospital Plaza, Suite 5108, St. Louis, MO 63110-1003 (US).
- (74) Agents: **RYAN, Daniel, D.** et al.; P.O. Box 26618, Milwaukee, WI 53226-0618 (US).
- (81) Designated States (unless otherwise indicated, for every kind of national protection available): AE, AG, AL, AM, AT, AU, AZ, BA, BB, BG, BR, BW, BY, BZ, CA, CH, CN, CO, CR, CU, CZ, DE, DK, DM, DZ, EC, EE, EG, ES, FI, GB, GD, GE, GH, GM, HR, HU, ID, IL, IN, IS, JP, KE, KG, KP, KR, KZ, LC, LK, LR, LS, LT, LU, LV, MA, MD, MG, MK, MN, MW, MX, MZ, NA, NI, NO, NZ, OM, PG, PH, PL, PT, RO, RU, SC, SD, SE, SG, SK, SL, SY, TJ, TM, TN, TR, TT, TZ, UA, UG, US, UZ, VC, VN, YU, ZA, ZM, ZW.
- (84) Designated States (unless otherwise indicated, for every kind of regional protection available): ARIPO (BW, GH, GM, KE, LS, MW, MZ, NA, SD, SL, SZ, TZ, UG, ZM, ZW), Eurasian (AM, AZ, BY, KG, KZ, MD, RU, TJ, TM), European (AT, BE, BG, CH, CY, CZ, DE, DK, EE, ES, FI, FR, GB, GR, HU, IE, IS, IT, LT, LU, MC, NL, PL, PT, RO, SE, SI, SK, TR), OAPI (BF, BJ, CF, CG, CI, CM, GA, GN, GQ, GW, ML, MR, NE, SN, TD, TG).
- Published:**
— without international search report and to be republished upon receipt of that report
- For two-letter codes and other abbreviations, refer to the "Guidance Notes on Codes and Abbreviations" appearing at the beginning of each regular issue of the PCT Gazette.*

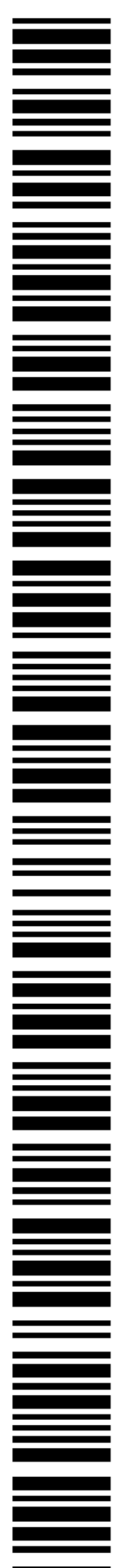

WO 2005/067660 A2

(54) Title: PROSTHESIS SYSTEMS AND METHODS SIZED AND CONFIGURED FOR THE RECEIPT AND RETENTION OF FASTENERS

(57) Abstract: Systems and methods introduce and deploy prosthesis into a blood vessel or hollow body organ. The prosthesis is secured in place by fasteners, and includes a region or regions specially sized and configured to receive and retain the fasteners.

- 1 -

**PROSTHESIS SYSTEMS AND METHODS SIZED AND CONFIGURED FOR
THE RECEIPT AND RETENTION OF FASTENERS**

Related Application

This application claims the benefit of United
5 States Patent Application Serial No. 10/693,255, filed
October 24, 2003, and entitled "Multi-Lumen Prosthesis
Systems and Methods."

Background of the Invention

The weakening of a vessel wall from damage or
10 disease can lead to vessel dilatation and the formation
of an aneurysm. Left untreated, an aneurysm can grow in
size and may eventually rupture.

For example, aneurysms of the aorta primarily
occur in abdominal region, usually in the infrarenal area
15 between the renal arteries and the aortic bifurcation.
Aneurysms can also occur in the thoracic region between
the aortic arch and renal arteries. The rupture of an
aortic aneurysm results in massive hemorrhaging and has a
high rate of mortality.

20 Open surgical replacement of a diseased or
damaged section of vessel can eliminate the risk of
vessel rupture. In this procedure, the diseased or
damaged section of vessel is removed and a prosthetic
graft, made either in a straight or bifurcated
25 configuration, is installed and then permanently attached

- 2 -

and sealed to the ends of the native vessel by suture. The prosthetic grafts for these procedures are usually unsupported woven tubes and are typically made from polyester, ePTFE or other suitable materials. The grafts
5 are longitudinally unsupported so they can accommodate changes in the morphology of the aneurysm and native vessel. However, these procedures require a large surgical incision and have a high rate of morbidity and mortality. In addition, many patients are unsuitable for
10 this type of major surgery due to other co-morbidities.

Endovascular aneurysm repair has been introduced to overcome the problems associated with open surgical repair. The aneurysm is bridged with a vascular prosthesis, which is placed intraluminally. Typically
15 these prosthetic grafts for aortic aneurysms are delivered collapsed on a catheter through the femoral artery. These grafts are usually designed with a fabric material attached to a metallic scaffolding (stent) structure, which expands or is expanded to contact the
20 internal diameter of the vessel. Unlike open surgical aneurysm repair, intraluminally deployed grafts are not sutured to the native vessel, but rely on either barbs extending from the stent, which penetrate into the native vessel during deployment, or the radial expansion force
25 of the stent itself is utilized to hold the graft in position. These graft attachment means do not provide the same level of attachment when compared to suture and can damage the native vessel upon deployment.

Summary of the Invention

30 The invention provides apparatus and methods for repairing diseased and/or damaged sections of a hollow body organ and/or a blood vessel.

One aspect of the invention provides systems and methods that include a prosthesis for a blood vessel
35 or hollow body organ. The prosthesis comprises a trunk

- 3 -

that includes a prosthetic material and a scaffold. The scaffold supports the prosthetic material to define a lumen within the trunk. The trunk includes a main body region and a fastening region. The fastening region is configured differently than the main body region for the receipt and retention in the second region of at least one fastener implanted into tissue by an external fastener attachment assembly.

The different configuration of the fastening region can comprise, e.g., a prosthetic material in the fastening region that is different than a prosthetic material in the main body region; and/or a prosthetic material in the fastening region that includes more layers than the prosthetic material in the main body region; and/or a prescribed weave pattern in the fastening region that is not present in the main body region; and/or a prescribed weave pattern in the fastening region that is denser than a weave pattern in the main body region; and/or a scaffold configuration in the fastening region that is different than a scaffold configuration in the main body region.

Other features and advantages of the invention shall be apparent based upon the accompanying description, drawings, and claims.

25 Brief Description of the Drawings

The invention will be understood from the following detailed description of preferred embodiments, taken in conjunction with the accompanying drawings, wherein:

30 Fig. 1 is a perspective view of a tissue reinforcement prosthesis having a fastening region that accommodates the introduction of one or more fasteners.

Fig. 2 is a perspective view of a prosthesis system that includes the tissue reinforcement prosthesis shown in Fig. 1 and an auxiliary prosthesis that, in use,

- 4 -

is telescopically anchored and supported by the tissue reinforcement prosthesis.

Fig. 3 is a perspective view of the tissue reinforcement prosthesis shown in Fig. 1, showing the attachment of fasteners in the fastening region.

Fig. 4 is a perspective view of the tissue reinforcement prosthesis shown in Fig. 1 positioned within a hollow body organ by use of fasteners.

Fig. 5A is a perspective view of the tissue reinforcement prosthesis shown in Fig. 1 positioned within the proximal neck of an abdominal aortic aneurysm.

Fig. 5B is a perspective view of the tissue reinforcement prosthesis shown in Fig. 5A, with the inclusion of an optional supra-renal stent.

Fig. 6A is a perspective view of a prosthesis system that includes the tissue reinforcement prosthesis shown in Fig. 5A positioned within a proximal neck of the abdominal aortic aneurysm and an auxiliary prosthesis that is telescopically anchored and supported by the tissue reinforcement prosthesis and that bridges the aneurysm.

Fig. 6B is an enlarged view of the system shown in Fig. 6A, showing the telescopic fitment of the auxiliary prosthesis in the tissue reinforcement prosthesis.

Fig. 6C is an enlarged view of the system shown in Fig. 6A, showing a telescopic, interlocking fitment of the auxiliary prosthesis in the tissue reinforcement prosthesis.

Figs. 7, 8, and 9 are perspective views of the deployment of the system shown in Fig. 6A by the sequential use of various intra-vascular catheters, one to deploy the tissue reinforcement prosthesis (Fig. 7), another to apply fasteners to the tissue reinforcement prosthesis (Fig. 8), and another to deploy the auxiliary prosthesis (Fig. 9).

- 5 -

Fig. 10 is a perspective view of prosthesis positioned within an abdominal aortic aneurysm, the prosthesis having a fastening region that accommodates the introduction of one or more fasteners.

5 Fig. 11 is a perspective view of prosthesis positioned within an abdominal aortic aneurysm, the prosthesis having a tapered trunk located, at its proximal end, within the aorta and, at its distal end, in an iliac, the prosthesis also having a fastening region
10 that accommodates the introduction of one or more fasteners.

Detailed Description of the Invention

I. Tissue Reinforcement Prosthesis

A. Structure

15 Fig. 1 shows a tissue reinforcement prosthesis
10 that embodies features of the invention. The prosthesis 10 serves to reinforce a region of a vessel wall or hollow body organ which has been weakened by disease or damage. As will be described in greater detail
20 later, the prosthesis 10 desirable provides a platform on which to deploy a second prosthesis 36 (see Fig. 2) in the vessel or hollow body organ. In this arrangement, the reinforcement prosthesis 10 comprises a component part of an overall prosthesis system 52.

25 In the illustrated embodiment (see Fig. 1), the prosthesis 10 comprises a tubular trunk 12. The trunk 12 is sized and configured to fit within a targeted region of a hollow body organ and/or a blood vessel. The targeted region is selected on the basis of certain
30 anatomic characteristics. These characteristics include a weakened conditioned caused, e.g., by disease or damage.

The trunk 12 forms a generally cylindrical structure with an open interior lumen 18. The trunk 12 fortifies the body organ or blood vessel in the targeted
35 region, to keep it from collapsing.

- 6 -

In the illustrated embodiment, the trunk 12 includes a prosthetic material 14 supported by a scaffold 16. The prosthetic material 14 is selected on the basis of its biocompatibility, durability, and flexible mechanical properties. The material 14 can comprise, e.g., woven polyester. Alternatively, a material comprising ePTFE can be used.

The scaffold 16 is desirable sized and configured to permit non-invasive deployment of the prosthesis 10 by an intra-vascular catheter. With this criteria in mind, the scaffold 16 is sized and configured to assume a compressed or collapsed, low profile condition, to permit its intra-vascular introduction into the hollow body organ and/or blood vessel by a catheter, as will be described in greater detail later.

Also with this criteria in mind, the scaffold 16 is sized and configured for expansion in situ from its collapsed condition into an expanded condition in contact with tissue in the targeted region, as will also be described in greater detail later.

In this respect, the scaffold 16 can comprise, e.g., a malleable plastic or metal material that expands in the presence of an applied force. In this arrangement, the deployment catheter can include, e.g., an expandable body, such as a balloon, to apply the expansion force to the scaffold 16 in situ.

Alternatively, the scaffold 16 can comprise a self-expanding plastic or metal material that can be compressed in the presence of a force, but self-expands upon removal of the compressive force. In this arrangement, the deployment catheter can include, e.g., a sleeve that can be manipulated to enclosed the scaffold 16 in a collapsed condition, thereby applying the compressive force, and to release the scaffold 16 when desired to allow the scaffold 16 to self-expand in situ.

For self-expansion, the scaffold 16 can

- 7 -

include individual self-expanding, zigzag type main stent rings 22. The main stent rings 22 can be made, e.g., from Nitinol[®] wire. Still, other materials, manufacturing methods and designs can be used.

5 The main stent rings 22 need not be attached to one another throughout the prosthesis material 14. The individual main stent rings 22 allow for longitudinal compliance while maintaining radial support of the open interior lumen 18. This technical feature allows the
10 prosthesis 10 to more readily accommodate changes in morphology in the targeted region. Still, it may be desirable in certain locations within the prosthesis structure to have attachments between the individual main stent rings 22 to provide enhanced stability and/or
15 additional radial support.

Each of the main stent rings 22 can be, e.g., sewn onto prosthetic material 14. In the illustrated embodiment, in which the prosthetic material 14 is woven polyester, the attachment of the main stent rings 22 can
20 be made, e.g., with polyester suture.

However, it is also contemplated that other attachment means could be utilized to secure the main stent rings 22 to the prosthetic material 14. These means include bonding; capturing the main stent rings 22
25 between two layers of prosthetic material 14; and incorporating the main stent rings 22 directly into the prosthetic material 14.

In certain locations it is desired to have the main stent rings 22 attached to the outer diameter of the
30 prosthetic material 14. Still, it is also contemplated that the main stent rings 22 could be attached to the inner diameter of the prosthetic material 22.

At least one end of the trunk 12 desirably also includes one or more end stent rings 24. The
35 principal purpose of an end stent ring 24 is to provide a seal between the trunk 12 and adjoining tissue. This

- 8 -

sealing function is particularly desirable when the prosthesis 10 is deployed in a blood vessel or other body organ, where body fluids are intended to reside or pass through the prosthesis 10. The end stent rings 24 can also serve, with the main stent rings 22, to help maintain the position of the prosthesis 10 in the targeted region.

Since the end stent rings 24 desirably serve more of a sealing function than a retention function, the end stent rings 24 are desirably more compliant than the main stent rings 22. The end stent rings 24 also desirably occupy a minimum of area on the trunk 12.

The trunk 12 (material 14 and/or scaffold 16) can carry radiopaque markers 46 to help fluoroscopically position the prosthesis 10. The markers 46 can take the form, e.g. of marker bands, tight wound coils, or wire made from radiopaque materials such as platinum, platinum/iridium, or gold.

The trunk 12 also desirably includes at least one fastening region 26 that accommodates the introduction of one or more fasteners 28 to anchor the prosthesis 10 in place (see Fig. 3). It is desirable that this region 26 of the trunk 12 be specially sized and configured for the receipt and retention of fasteners 28. For example, the size and spacing of ring stent patterns can be configured in the region 26 to specially accommodate the placement of fasteners; and/or woven fibers with an "X-pattern" or a "sinusoidal pattern" can be used in the region 26 to specially accommodate placement of fasteners; and/or the prosthetic material 14 can be folded-over to form multiple layers, to reinforce the prosthesis in the region 26 where fasteners are placed; and/or denser weave patterns or stronger fibers can be used, selected from, e.g., Kevlar™ material or Vectran™ material or metallic wire woven alone or interwoven with typical polyester fibers in the region 26

- 9 -

were fasteners are placed. It may also be desirable to fluoroscopically indicate this region 26 with auxiliary radiopaque markers 30 on the prosthetic material 14, and/or auxiliary stent rings 32 to aid in positioning the
5 fasteners.

The fasteners 28 can be variously constructed. They can, e.g., comprise helical fasteners or staples.

Desirably, like the prosthesis 10 itself, the fasteners 28 are introduced by an intra-vascular fastener attachment assembly. Details of a fastener attachment
10 assembly that deploys helical fasteners can be found in United States Patent Application Serial No. 10/307,226, filed November 29, 2002, which is incorporated herein by reference.

15 B. Use of the Tissue Reinforcement Prosthesis

The targeted region for deployment of the tissue reinforcement prosthesis 10 as just described can vary. For example, the targeted region can comprise a
20 damaged or weakened area within a given body organ, as Fig. 4 shows. In this embodiment, the presence of prosthesis 10 provides reinforcement to the body organ where damage or weakness exists.

As another example (see Fig. 5A), the targeted
25 region can comprise an aorta with an aneurysm. The use of a tissue reinforcement prosthesis 10 in this targeted region could be indicated, e.g., when the neck proximal to the aneurysm (i.e., closest to the head) is either too short or otherwise has a native anatomic feature that
30 interferes with the secure placement of a conventional endovascular prosthesis to bridge the aneurysm. In this embodiment, the presence of prosthesis 10 provides reinforcement to the proximal neck of the aneurysmal aorta adjacent the renal arteries.

35 When used for this purpose (see Fig. 6A), the reinforcement prosthesis 10 can also serve to anchor and

- 10 -

support an auxiliary prosthesis structure 36 that, in the absence of the reinforcement prosthesis 10, could not be deployed, due to native anatomic features of the vessel. In the illustrated embodiment, the auxiliary prosthesis structure 36 comprises an endovascular graft that, when
5 deployed, bridges the aneurysm. Together, the reinforcement prosthesis 10 and the graft 36 form a prosthesis system 52, as shown in Fig. 6A.

In this arrangement, the graft 36 includes a
10 proximal end 38 that is sized and configured to be telescopically fitted within the lumen 18 of the trunk 12. The lumen 18 of the trunk 12, provides an interface region or socket 40 (see Fig. 6B) that is fully enclosed within the body of the trunk 12 itself. The lumen 18 is
15 therefore not prone to kinking or twisting or other kinds of movement independent of the trunk 12.

It is desirable that the socket region 40 of the trunk 12 be specially sized and configured for the receipt and retention of the auxiliary graft 36, e.g., by
20 the use of folded-over materials to form multiple layers, and/or the use of denser weave patterns or stronger fibers from, e.g., Kevlar™ material or Vectran™ material or metallic wire woven alone or interwoven with typical polyester fibers in the socket region 40, additional
25 stent rings, and the like, to reinforce the prosthesis in the socket region 40 where hooks or barbs 60 of the graft 36 can obtain purchase; and/or by the use of radiopaque markers 42 to fluoroscopically identify the socket region 40 on the prosthetic material 14; and/or the use of
30 auxiliary stent rings on the inside of the prosthetic material 14 in the socket region 40 that interfere with exterior stent rings on the graft 36, to resist migration of graft 36 from the prosthesis 10.

Being telescopically fitted within the socket
35 region 40 (see Fig. 6B), and being also enclosed within the trunk 12 itself, the mechanical properties of the

- 11 -

graft 36 are supplemented by the reinforcement, support, and integrity of the socket region 40 and trunk 12 themselves, and vice versa. Coupled together, the trunk 12 and the graft 36 provide enhanced resistance to migration and/or separation of the graft 36 from the trunk 12. Seated within the enclosed socket region 40, the graft 36 is peripherally sealed within the trunk 12 to resist leaks or seepage of fluids around the graft 36.

To enhance the fitment between the trunk 12 and the graft 36 within the socket region 40, a mechanically interlocking relationship can be established. For example (as shown in Fig. 6C), a supplemental main stent ring 22A on the interior of the socket region 40 -- which would comprise the distal-most main stent ring of the trunk 12 -- could be provided to mechanically engage or nest with a supplemental main stent ring 22B on the exterior of the proximal end of the auxiliary prosthesis structure 36. The mechanical interference between the supplemental stent rings 22A and 22B serves to capture the auxiliary prosthesis structure 36 within the trunk 12, preventing both distal and proximal migration between the two prostheses 10 and 36. It should also be appreciated that the inside-outside nesting relationship in the junction between the two prostheses 10 and 36 as described can be reversed, along with the reversal of the order of deployment; that is, the auxiliary prosthesis structure 36 can be deployed first, and the prosthesis 10 deployed second to nest within an end of the auxiliary prosthesis structure 36, thereby elongating and reinforcing the neck region.

In this arrangement (see Fig. 5B), the trunk 12 may include a supra-renal stent 44 at its proximal end, which extends beyond the prosthetic material 14. When deployed within the aorta, this stent 44 would extend above the level of the renal arteries. The supra-renal stent 44 orients the prosthesis 10 within the lumen

- 12 -

and aids in maintaining the position of the prosthesis 10 in the aorta without obstructing the normal blood flow into the renal arteries.

During use (see Fig. 7), a first catheter 20 is navigated over a guide wire 48 through an iliac to the desired location within the aorta near the renal arteries. The catheter 20 carries the reinforcement prosthesis 10 in a radially reduced configuration. At the targeted site, the catheter 20 releases the reinforcement prosthesis 10, which expands radially into the position shown in Fig. 5A. When the reinforcement prosthesis 10 ultimately serves to anchor an auxiliary graft 36, the trunk 12 of the prosthesis 10 desirably extends distally from the proximal neck and partially into the aneurysm sac.

A fastener assembly 34 is next deployed (see Fig. 8) to place fasteners 28 into the end region 28 of the trunk 12. The prosthesis 10 is thereby secured in position.

The auxiliary graft 36 is carried in a radially compressed condition by another over-the-wire catheter 50 (see Fig. 9). The catheter 50 deploys the graft 36, such that the proximal end of the graft 36 is telescopically received within the socket region 40 of the trunk 12. The prosthesis system 52 is thereby formed.

II. Other Prostheses

A. Tubular Prosthesis for General Use

Any given tubular prosthesis 54 (see Fig. 10) can include a trunk 56 having a region 26 that is specially sized and configured for the receipt and retention of fasteners 28, in the ways previously described. In Fig. 10, the trunk 56 is sized and configured to extend, for purposes of illustration, in the aorta adjacent the renal arteries distally to a location proximal the natural bifurcation of the iliac

- 13 -

arteries. As shown in Fig. 10, the region 26 is located in the neck of the aorta adjacent to the renal arteries.

The features of the region 26, previously described, make possible the secure attachment of the prosthesis 54, without migration.

The prosthesis 54 desirable also includes other features of the prosthesis 10 already described, e.g., the main stent rings 22, the end stent rings 24, and the radiopaque markers 46. The prosthesis 54 can also include a supra-renal stent 44 of the type shown in Fig. 5B.

B. Aorta Iliac Prosthesis

As shown in Fig. 11, the trunk 58 of a given prosthesis 56 may be tapered, changing diameter from the proximal region to the distal region. In the embodiment shown in Fig. 11, the taper reduces the diameter of the trunk 58 in the proximal to distal direction. This taper direction is well suited for placement of the prosthesis 56, at its proximal end, in the aorta adjacent the renal arteries and, at its distal end, in an iliac artery, as Fig. 11 shows.

The trunk 58 of the prosthesis 56 desirable also includes a region 26 that is specially sized and configured for the receipt and retention of fasteners 28, in the ways previously described. As shown in Fig. 11, the region 26 is located in the neck of the aorta adjacent to the renal arteries. The features of the region 26, previously described, make possible the secure attachment of the prosthesis 56, without migration.

The prosthesis 56 desirable also includes other features of the prosthesis 10 already described, e.g., the main stent rings 22, the end stent rings 24, and the radiopaque markers 46. The prosthesis 54 can also include a supra-renal stent 44 of the type shown in Fig. 5B.

As described with respect to Figs. 10 and 11,

- 14 -

the targeted site of deployment is within the aorta adjacent the renal arteries. However, this targeted site of deployment is selected for purposes of illustrating the features of the prostheses 54 and 56, and is not
5 intended to be limiting.

The preferred embodiments of the invention are described above in detail for the purpose of setting forth a complete disclosure and for the sake of explanation and clarity. Those skilled in the art will
10 envision other modifications within the scope and spirit of the present disclosure.

The above described embodiments of this invention are merely descriptive of its principles and are not to be limited. The scope of this invention
15 instead shall be determined from the scope of the following claims, including their equivalents.

- 15 -

We Claim:

1. A prosthesis for a blood vessel or hollow body organ comprising a trunk including a prosthetic material and a scaffold that supports the prosthetic material to define a lumen within the trunk, the trunk including a main body region and a fastening region configured differently than the main body region for the receipt and retention in the second region of at least one fastener implanted into tissue by an external fastener attachment assembly.

2. A prosthesis according to claim 1, wherein the fastening region comprises an end region of the trunk.

3. A prosthesis according to claim 2, wherein the end region includes a stent ring sized and configured to provide a seal between the end region and adjoining tissue.

4. A prosthesis according to claim 1, wherein the fastening region includes prosthetic material that is different than a prosthetic material in the main body region.

5. A prosthesis according to claim 4, wherein the prosthetic material in the fastening region includes more layers than the prosthetic material in the main body region.

6. A prosthesis according to claim 4, wherein the prosthetic material in the fastening region includes a prescribed weave pattern not present in the main body region.

7. A prosthesis according to claim 6, wherein the prescribed weave pattern is denser than a weave pattern in the main body region.

8. A prosthesis according to claim 6, wherein the prescribed weave pattern comprises an X-pattern.

- 16 -

9. A prosthesis according to claim 6, wherein the prescribed weave pattern comprises a sinusoidal pattern.

5 10. A prosthesis according to claim 4, wherein the prosthetic material in the fastening region includes a prescribed constituent not present in the main body region.

11. A prosthesis according to claim 10, wherein the prescribed constituent is metallic.

10 12. A prosthesis according to claim 10, wherein the prescribed constituent comprises a Kevlar™ material.

15 13. A prosthesis according to claim 10, wherein the prescribed constituent comprises a Vectran™ material.

14. A prosthesis according to claim 10, wherein the prescribed constituent is interwoven with material found in the main body region.

20 15. A prosthesis according to claim 1, wherein the fastening region includes a scaffold configuration that is different than a scaffold configuration in the main body region.

16. A prosthesis according to claim 1, wherein the scaffold includes self-expanding material.

25 17. A prosthesis according to claim 1, wherein the scaffold includes a malleable material.

18. A prosthesis according to claim 1, wherein the prosthetic material includes polyester.

30 19. A prosthesis according to claim 1, wherein the prosthetic material includes ePTFE.

20. A prosthesis according to claim 1, wherein the at least fastener comprises a helical fastener.

35 21. A prosthesis according to claim 1, wherein the main body region includes a socket sized and configured to couple an auxiliary prosthesis structure to

- 17 -

the trunk.

22. A prosthesis system for a blood vessel or hollow body organ comprising a first prosthesis comprising a trunk including a prosthetic material and a scaffold that supports the prosthetic material to define
5 a lumen within the trunk, the trunk including a main body region and a fastening region configured differently than the main body region for the receipt and retention in the second region of at least one fastener implanted into
10 tissue by an external fastener attachment assembly, the main body region including a socket region, the prosthesis system further including an auxiliary prosthesis structure coupled to the socket region.

23. A method for deploying a prosthesis in a
15 tissue region in a blood vessel or hollow body organ comprising the steps of providing a prosthesis comprising a trunk including a prosthetic material and a scaffold that supports the prosthetic material to define a lumen within the trunk, the trunk including a main body region
20 and a fastening region configured differently than the main body region for the receipt and retention in the second region of at least one fastener implanted into tissue by an external fastener attachment assembly, deploying the prosthesis in the tissue region, and
25 implanting at least one fastener in the fastening region to secure the prosthesis in the tissue region.

24. A method according to claim 23, further including the step of deploying an auxiliary prosthesis structure adjacent the prosthesis, and coupling the
30 auxiliary prosthesis structure to the trunk.

25. A method according to claim 23, wherein the prosthesis is deployed using an intra-vascular tool.

26. A method according to claim 25, further including the step of deploying using an intra-vascular
35 tool an auxiliary prosthesis structure adjacent the prosthesis, and coupling the auxiliary prosthesis

- 18 -

structure to the trunk.

27. A method according to claim 23, wherein the tissue region contains an aneurysm.

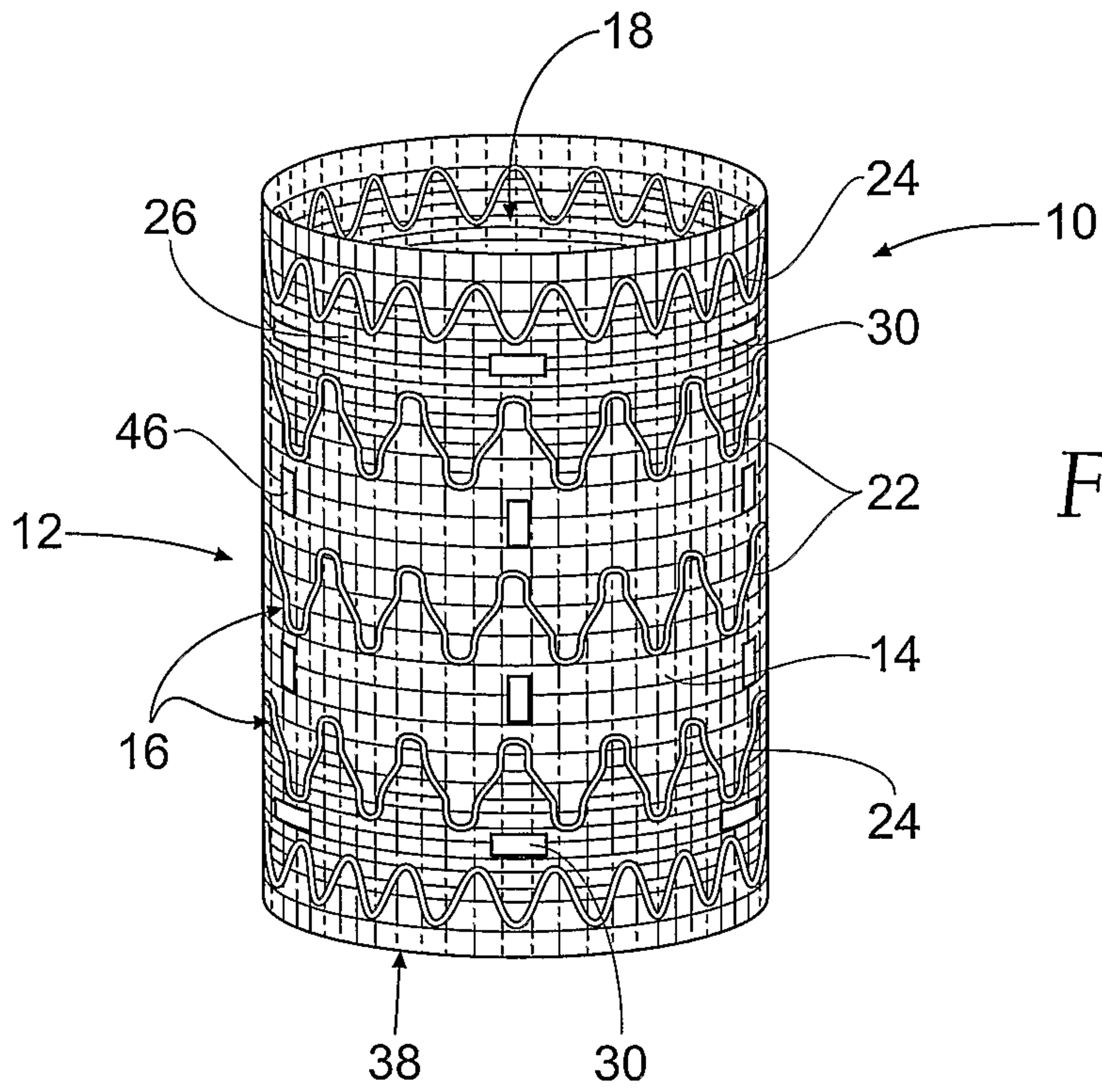

Fig. 1

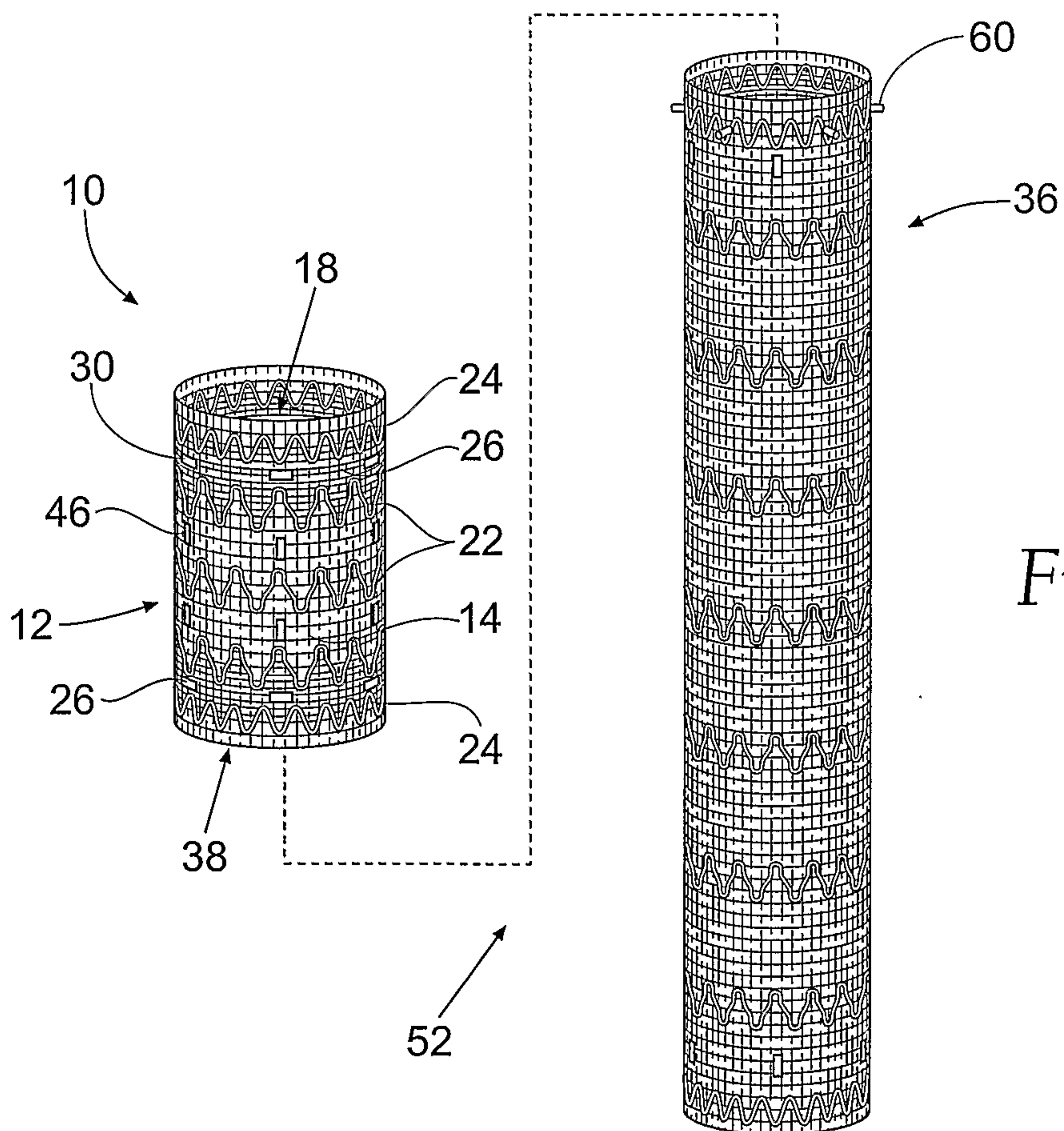
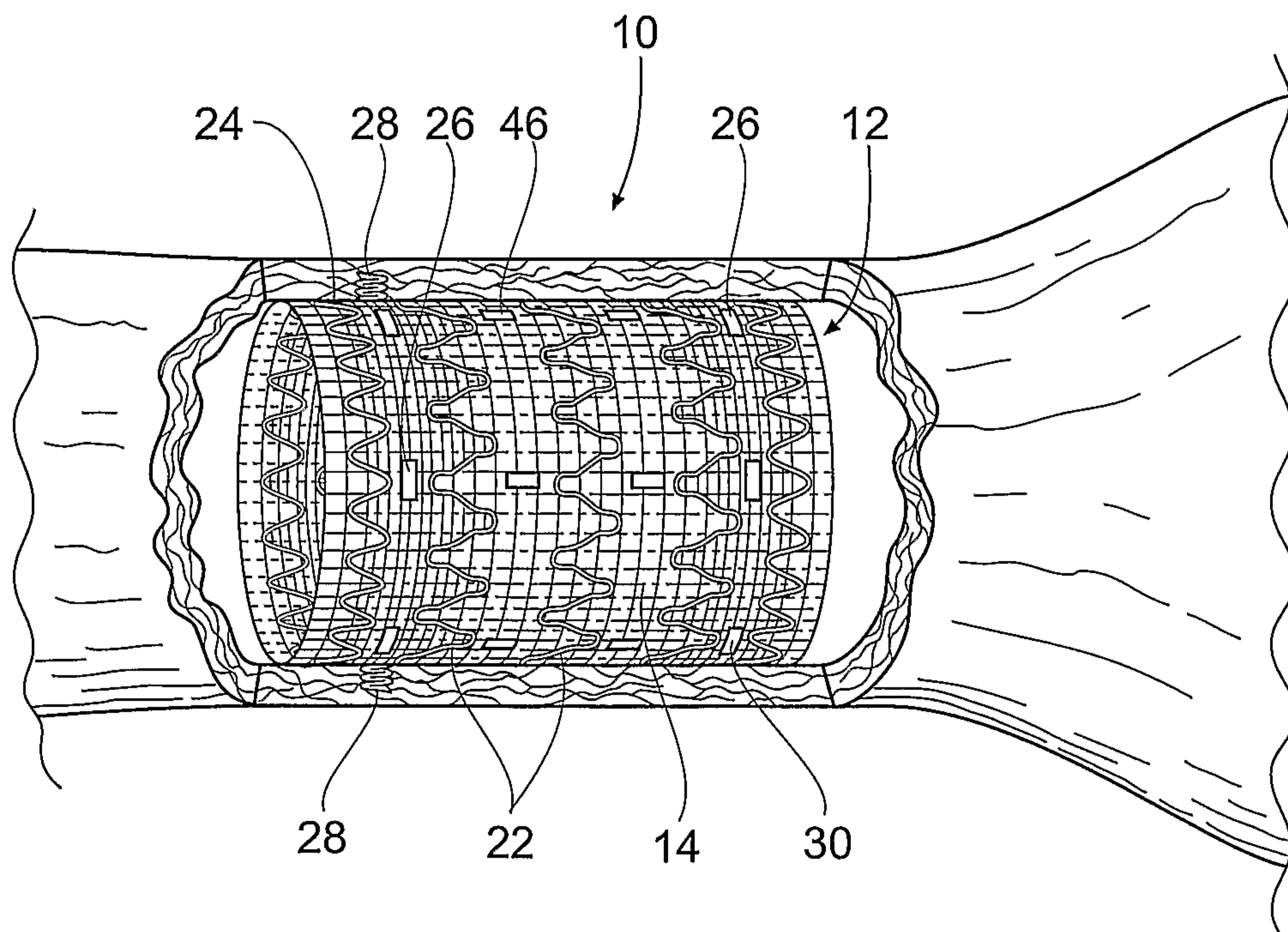
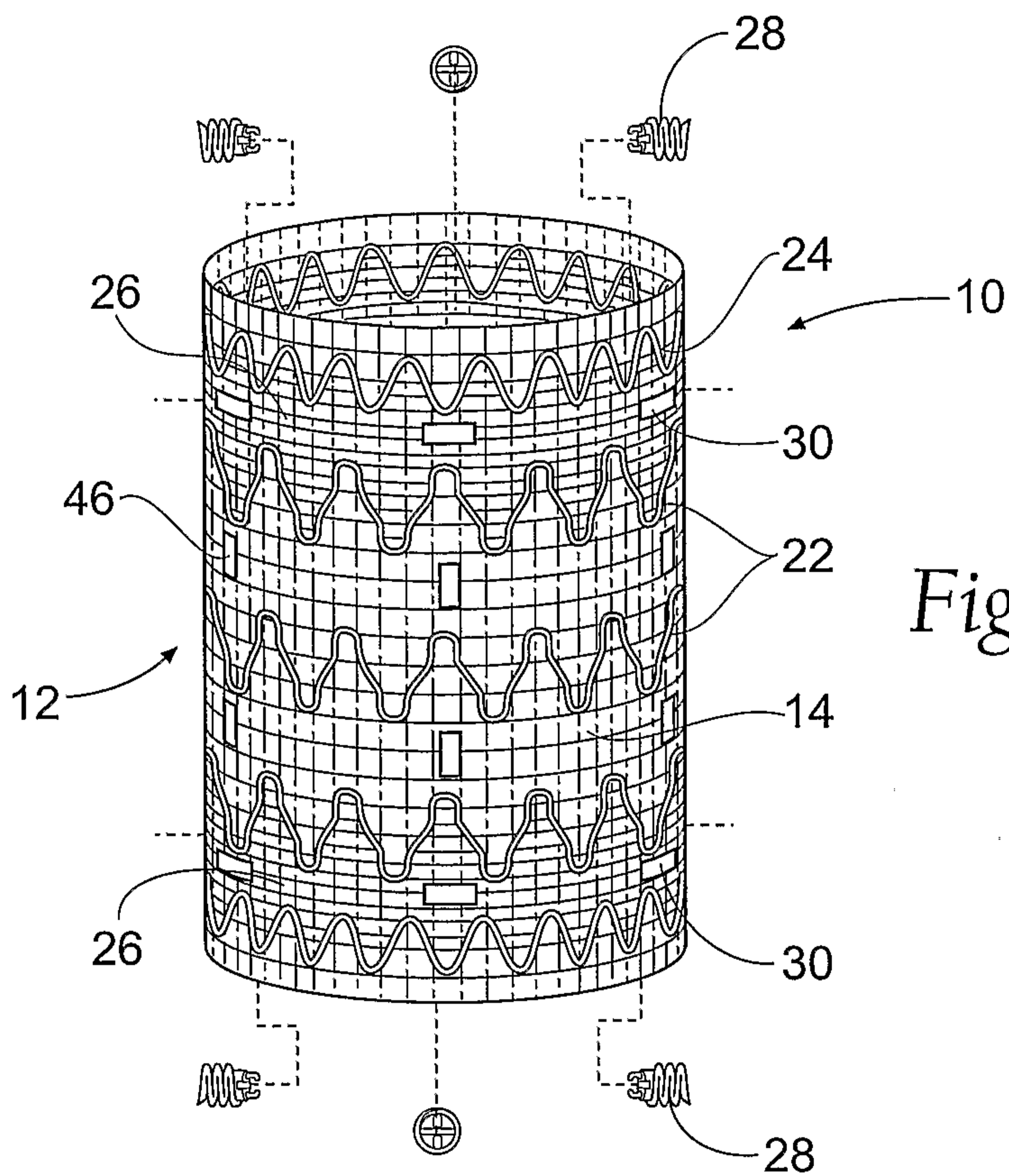

Fig. 2



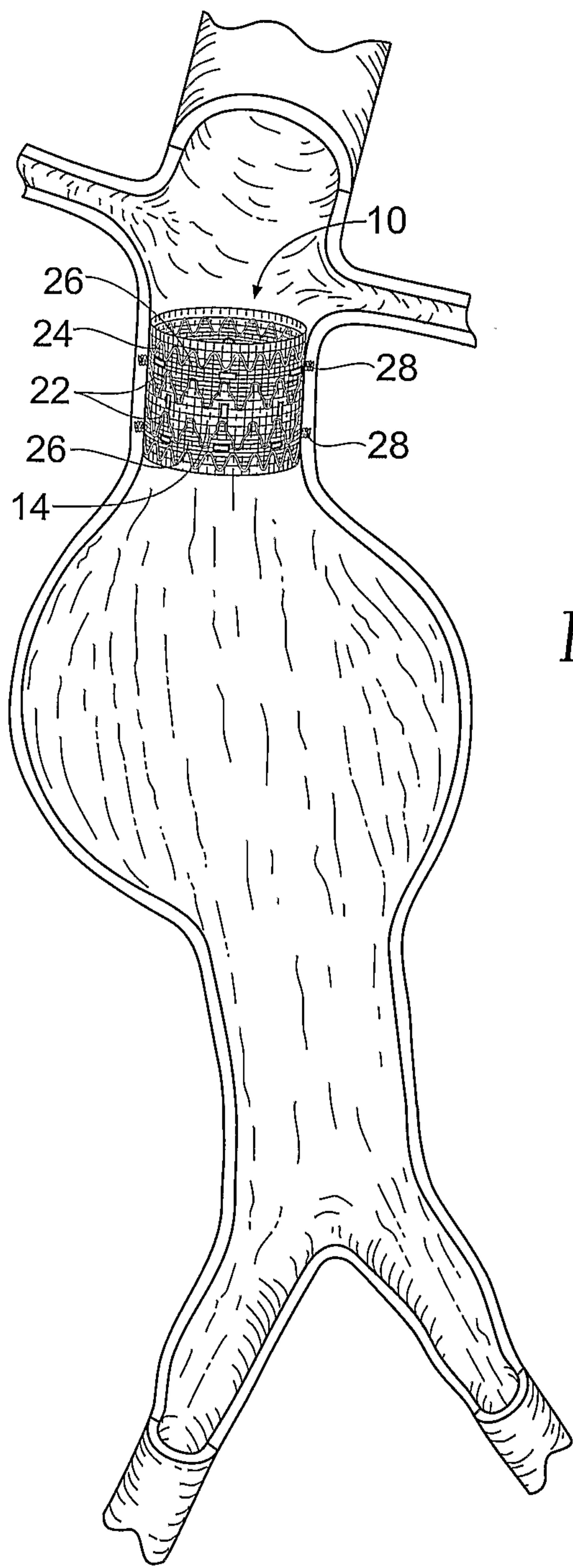

Fig. 5A

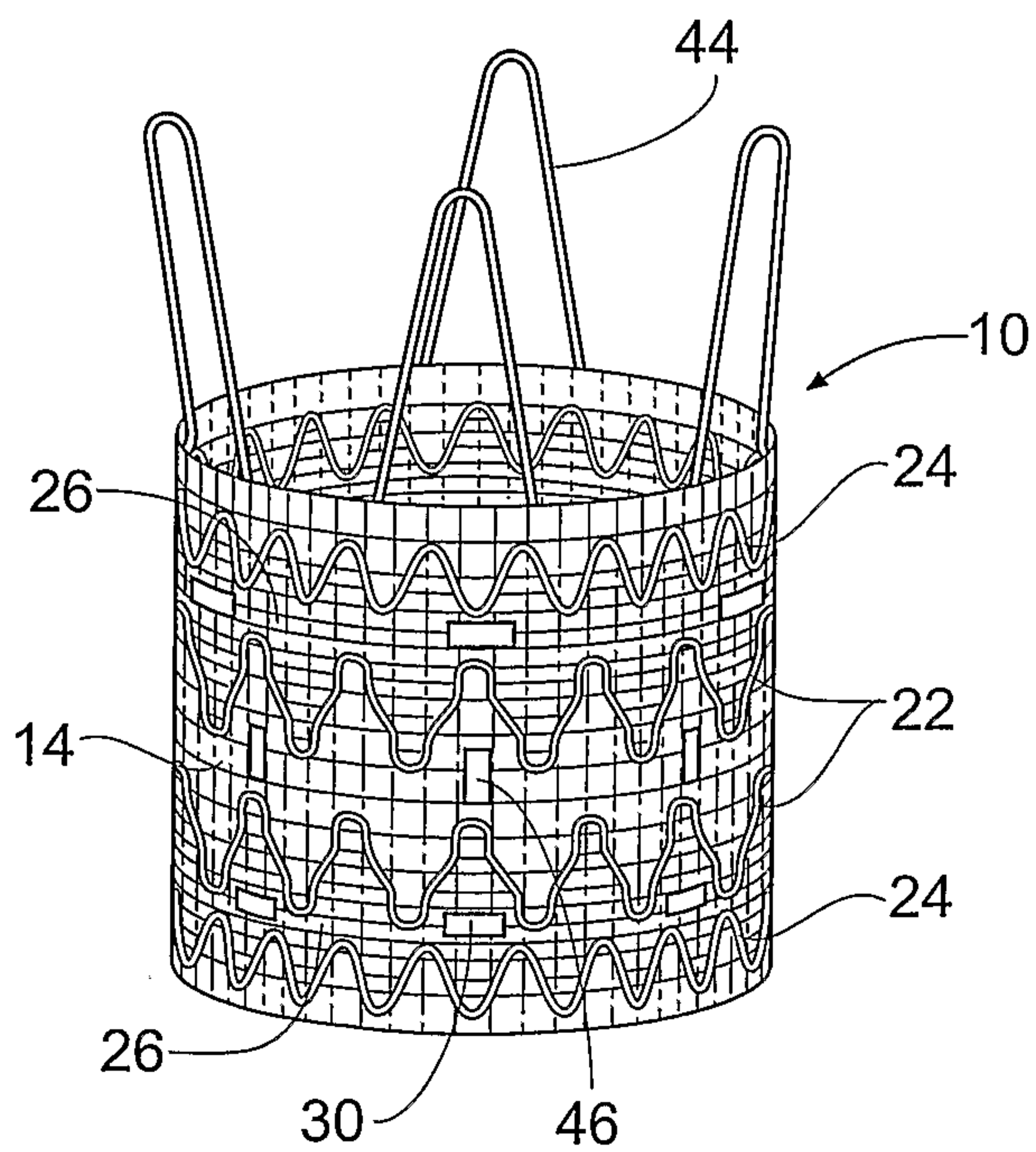

Fig. 5B

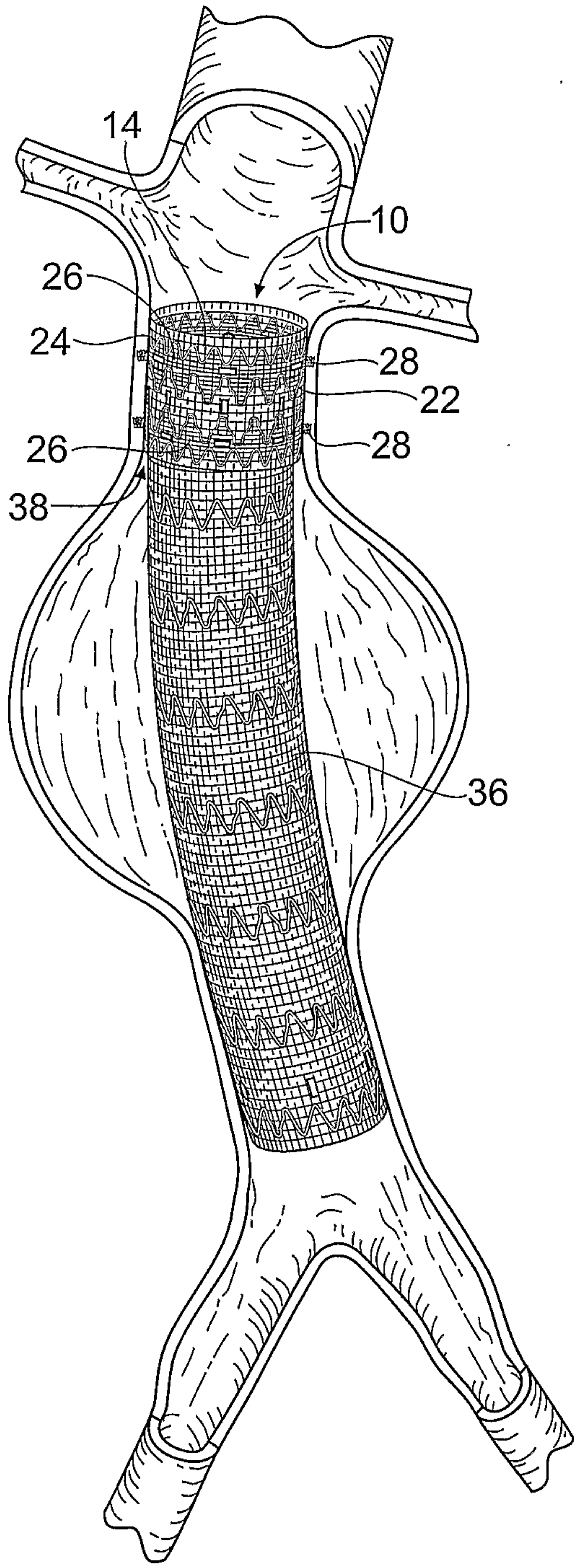

Fig. 6A

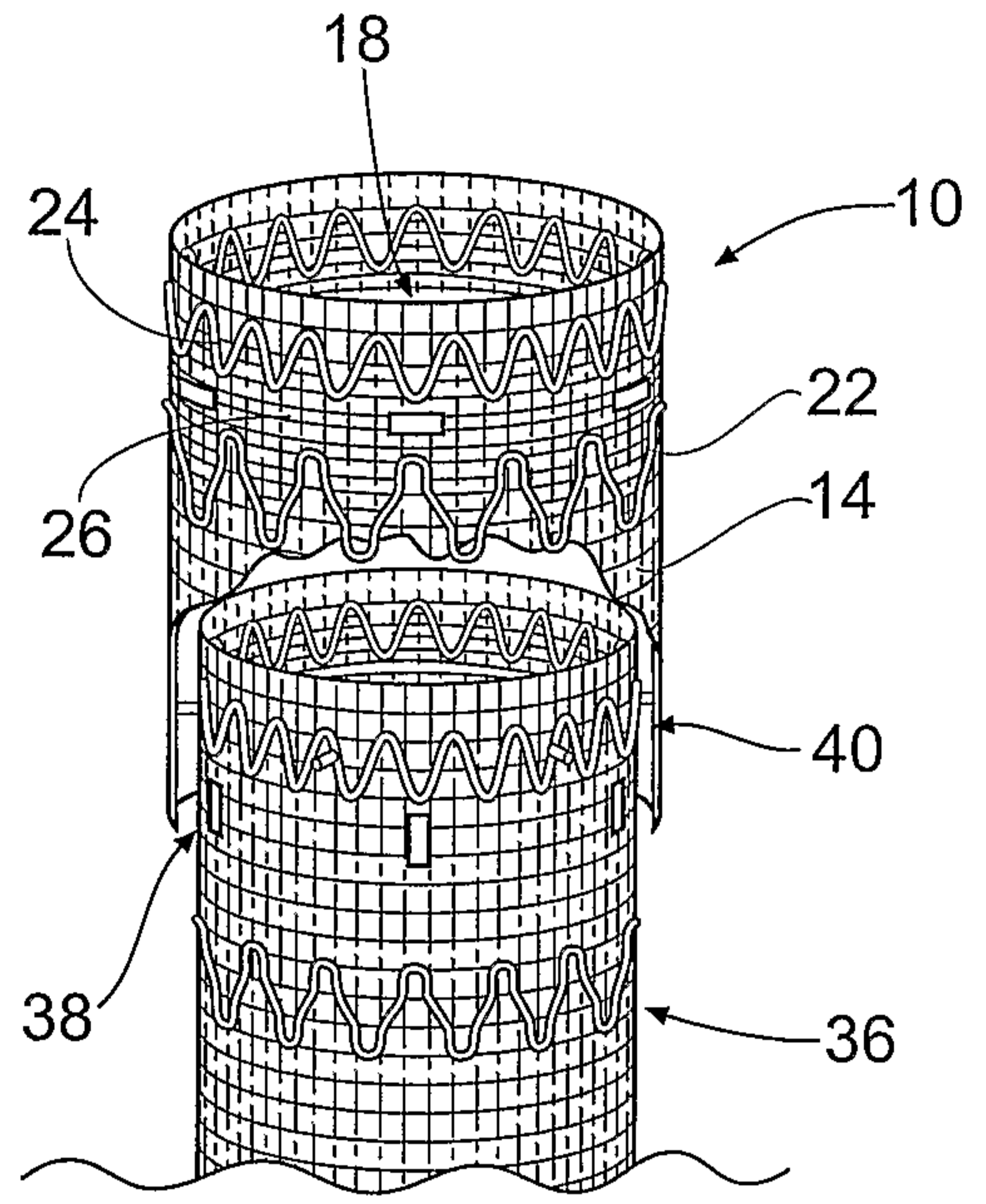

Fig. 6B

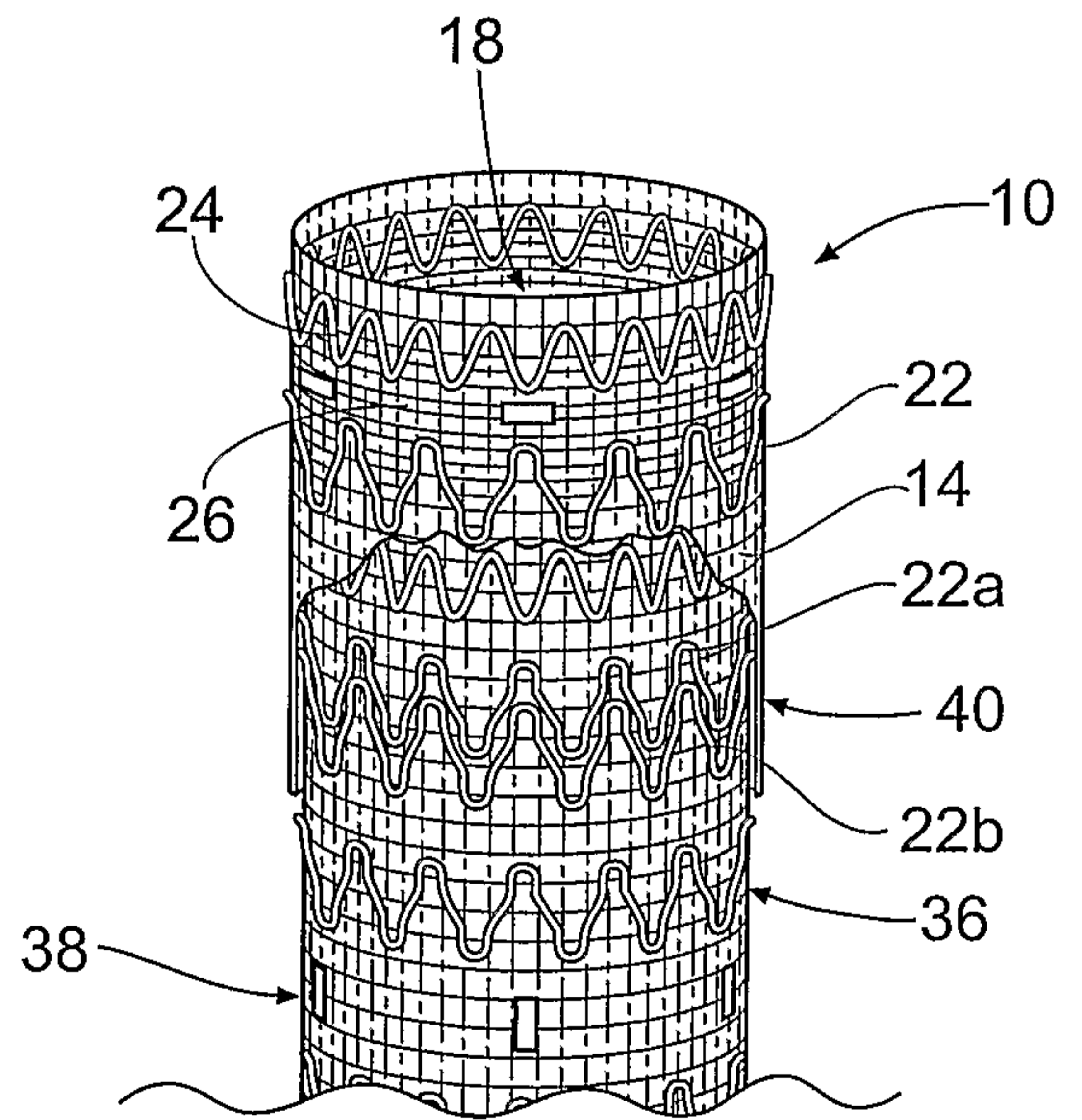

Fig. 6C

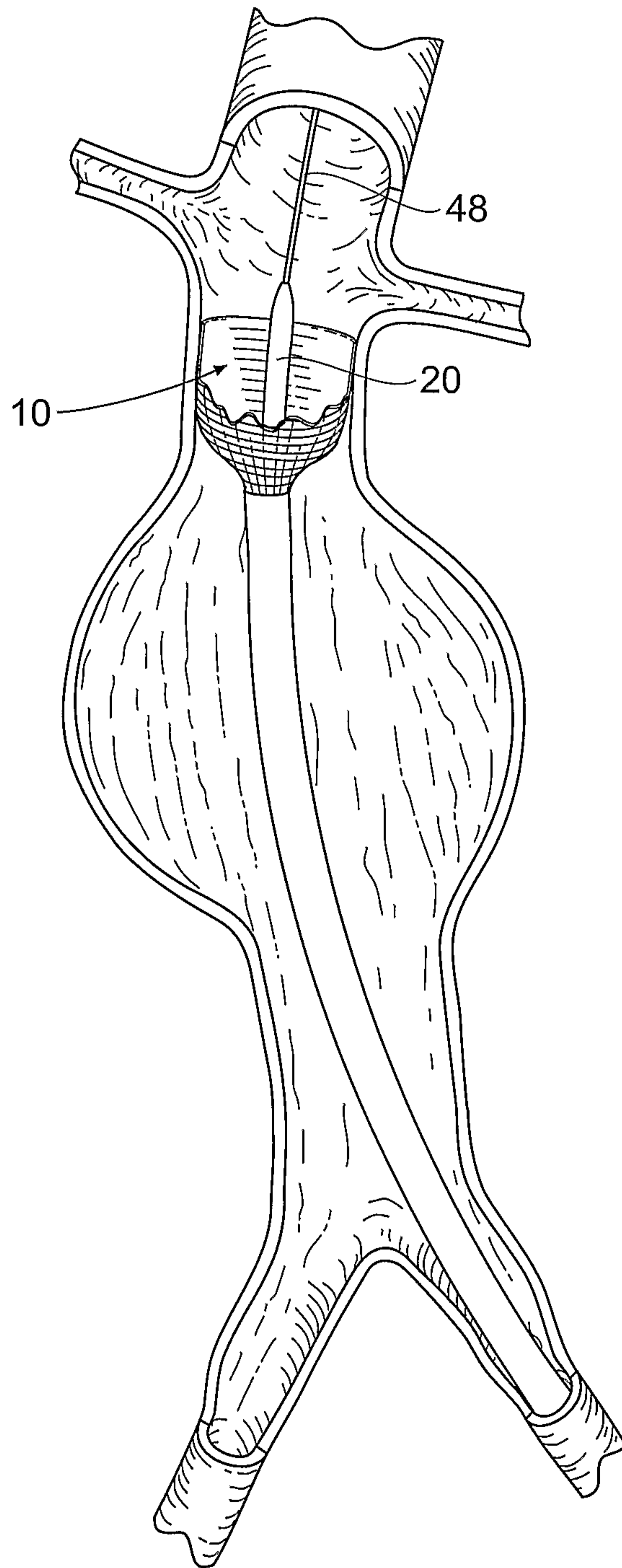

Fig. 7

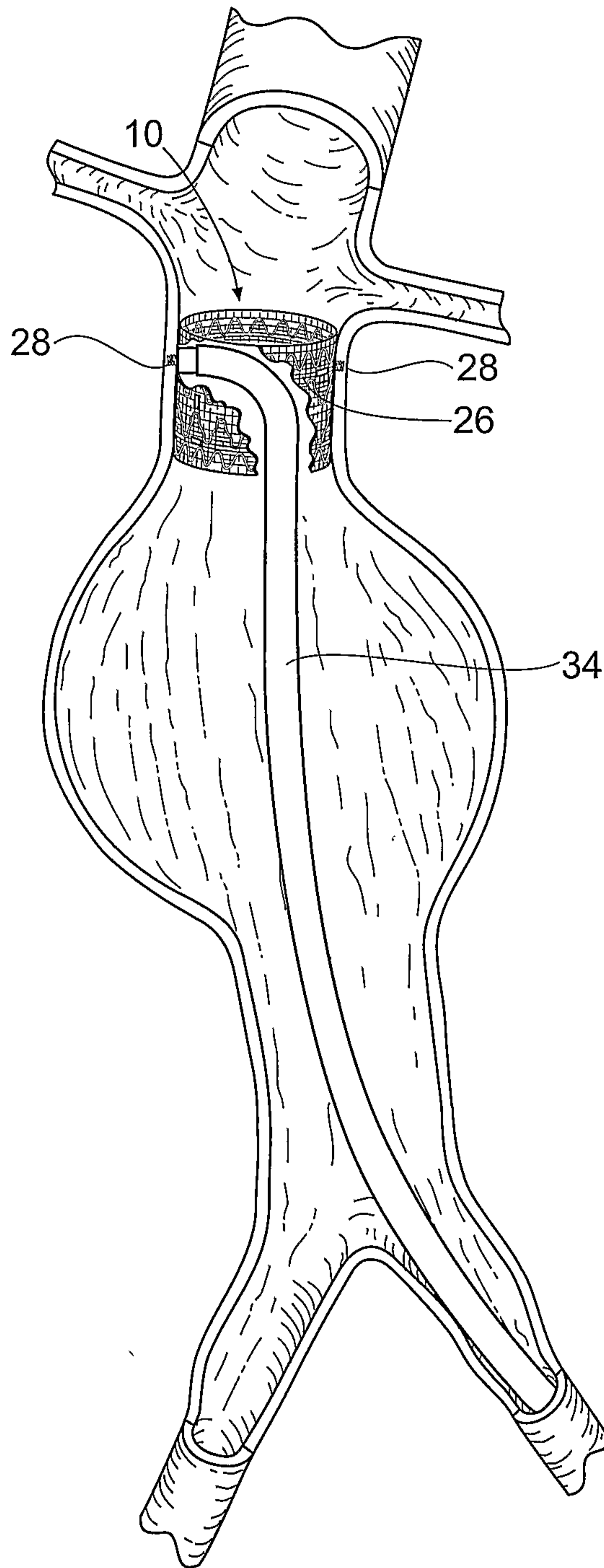

Fig. 8

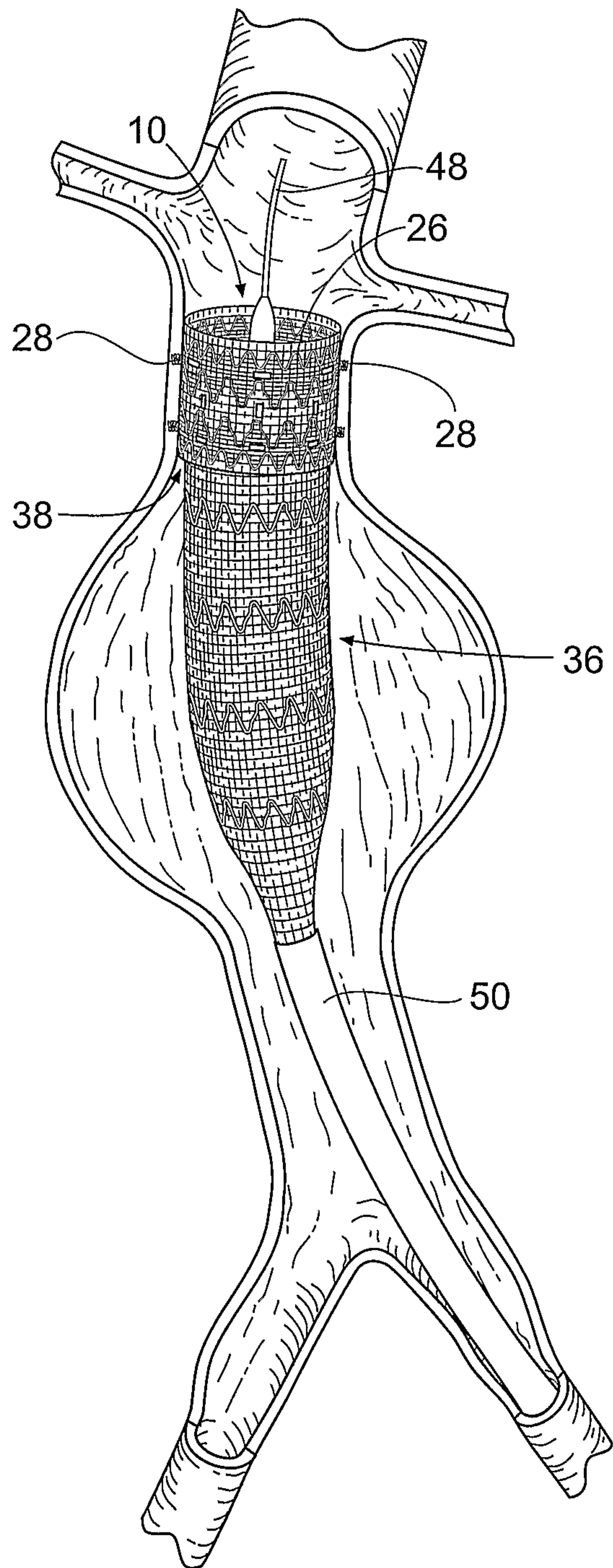

Fig. 9

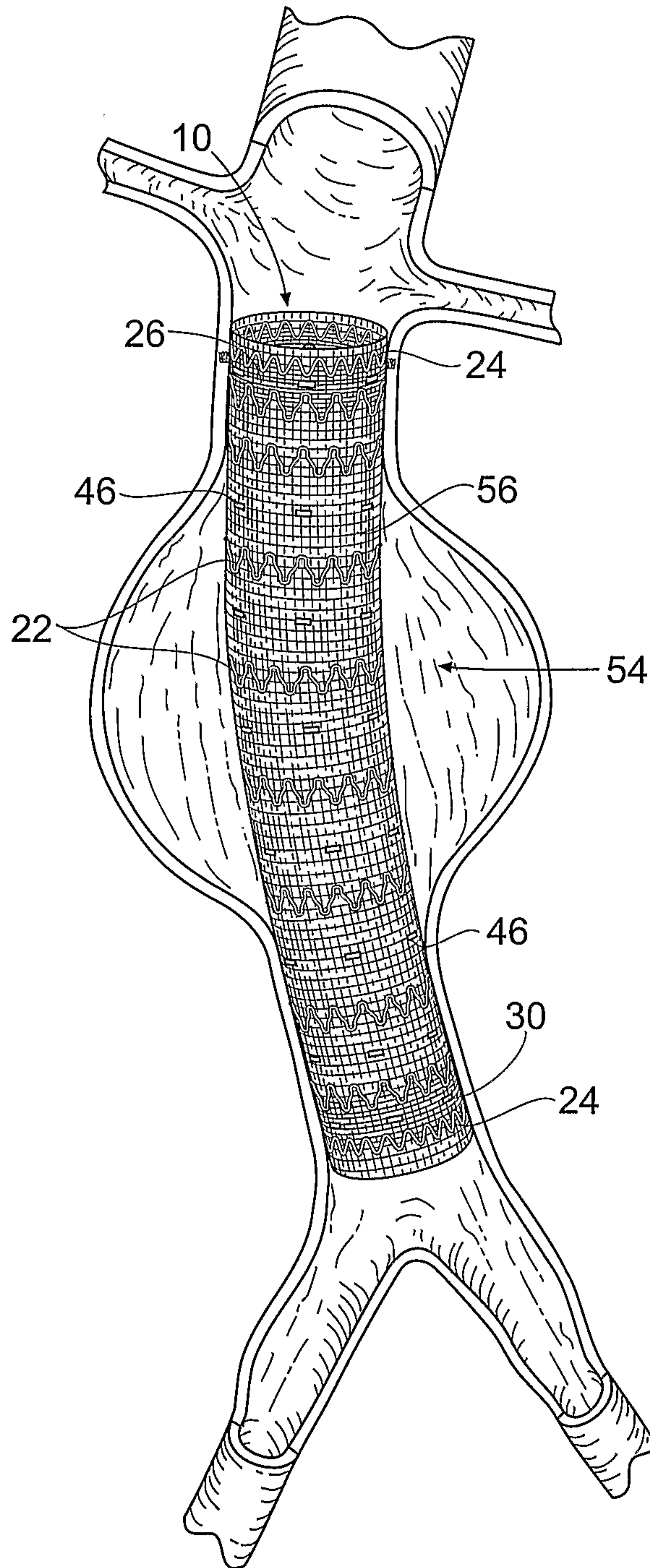

Fig. 10

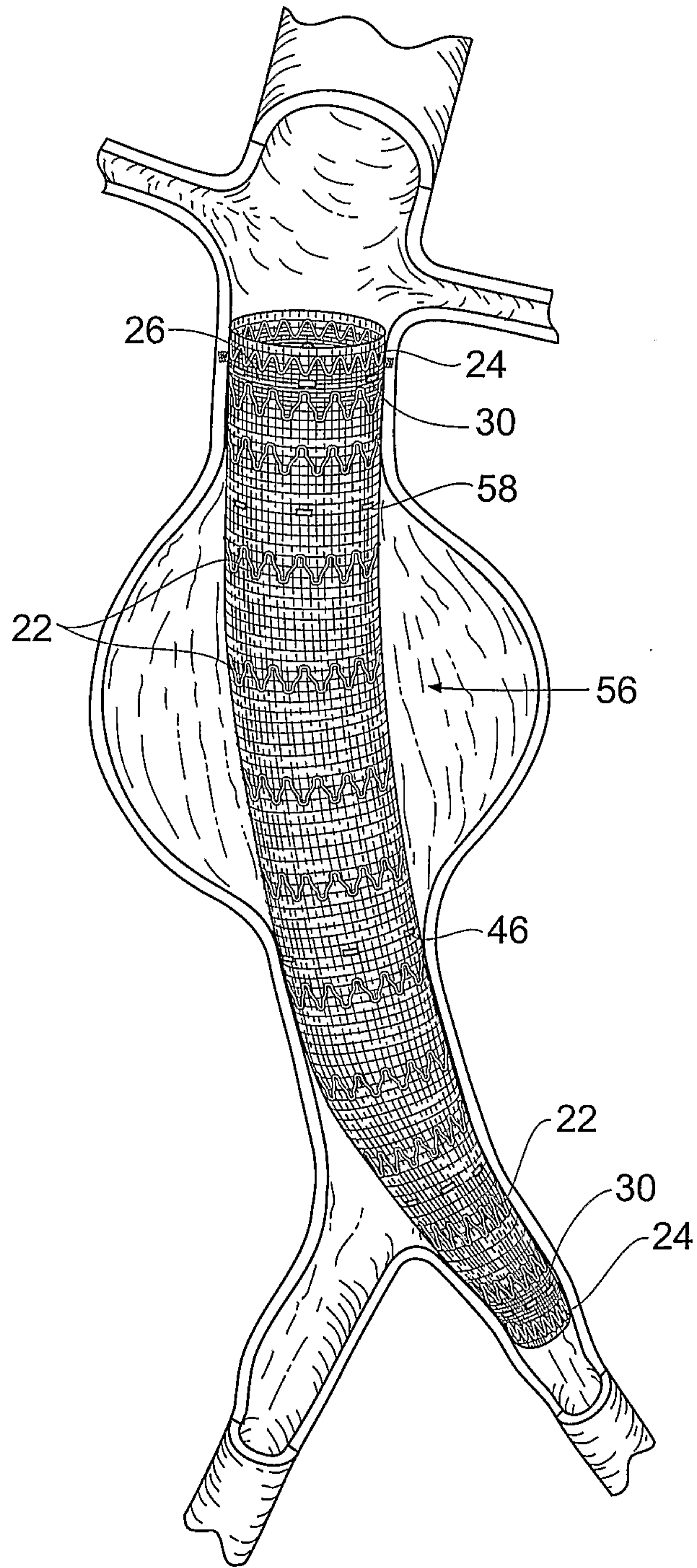

Fig. 11