



US006304442B1

(12) **United States Patent**
Tucker et al.

(10) **Patent No.:** **US 6,304,442 B1**
(45) **Date of Patent:** **Oct. 16, 2001**

(54) **ACTIVELY COOLED DAUGHTERBOARD SYSTEM**

| | | | | | |
|-----------|---|---------|-----------------|-------|---------|
| 5,936,836 | * | 8/1999 | Scholder | | 361/695 |
| 6,094,346 | * | 7/2000 | Schweers et al. | | 361/695 |
| 6,130,819 | * | 10/2000 | Lofland et al. | | 361/695 |
| 6,130,820 | * | 10/2000 | Konstad et al. | | 361/695 |

(75) Inventors: **Sean W. Tucker**, Loveland; **Arlen L Roesner**, Ft Collins; **Darren B Smith**; **Donald Trotter**, both of Loveland; **Andrew D Delano**, Ft. Collins, all of CO (US)

* cited by examiner

(73) Assignee: **Hewlett-Packard Company**, Palo Alto, CA (US)

Primary Examiner—Leo P. Picard
Assistant Examiner—Michael Datskovsky

(74) *Attorney, Agent, or Firm*—Kevin M. Hart

(*) Notice: Subject to any disclaimer, the term of this patent is extended or adjusted under 35 U.S.C. 154(b) by 0 days.

(57) **ABSTRACT**

An actively cooled daughterboard system. One more daughterboards are mounted in parallel rows on a motherboard. Each daughterboard is oriented substantially perpendicular to the motherboard, but may optionally be mounted at an oblique angle relative to the motherboard. Each daughterboard has a low-profile thermally-efficient heatsink mounted thereon. A fan shroud partially covers the daughterboards, but has openings in its sides for directing air flow through plural fins on the heatsinks and through a fan mounted to the top of the fan shroud. The inventive daughterboard system enables multiple high heat dissipating daughterboards to be placed closer together than the daughterboard systems of the prior art while still keeping the daughterboards adequately cooled. Moreover, because only a single fan is used to cool all of the daughterboards under the shroud, noise and expense are reduced relative to prior art systems that employed one or more fans per daughterboard.

(21) Appl. No.: **09/607,039**

(22) Filed: **Jun. 29, 2000**

(51) **Int. Cl.**⁷ **H05K 7/20**

(52) **U.S. Cl.** **361/695**; 361/704; 361/687; 361/697; 165/122; 165/104.32; 454/184

(58) **Field of Search** 364/683, 685-687, 364/690-697, 704-712, 714, 717-719, 735; 165/80.3, 80.4, 122, 104.32, 104.33, 40, 185, 121, 80.2; 257/706-727; 174/16.3, 16.1; 454/184; 62/259.2, 259.3, 259.7, 263

(56) **References Cited**

U.S. PATENT DOCUMENTS

5,884,692 * 3/1999 Lee et al. 165/80.3

12 Claims, 8 Drawing Sheets

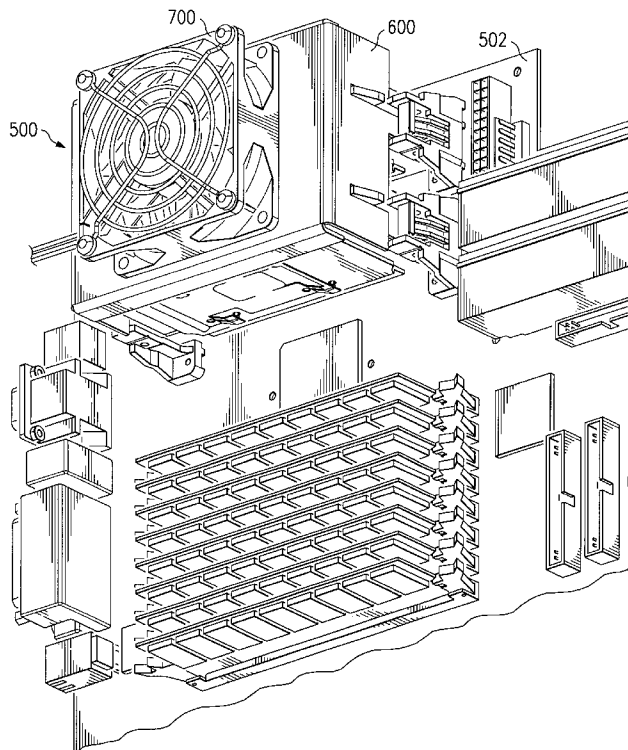

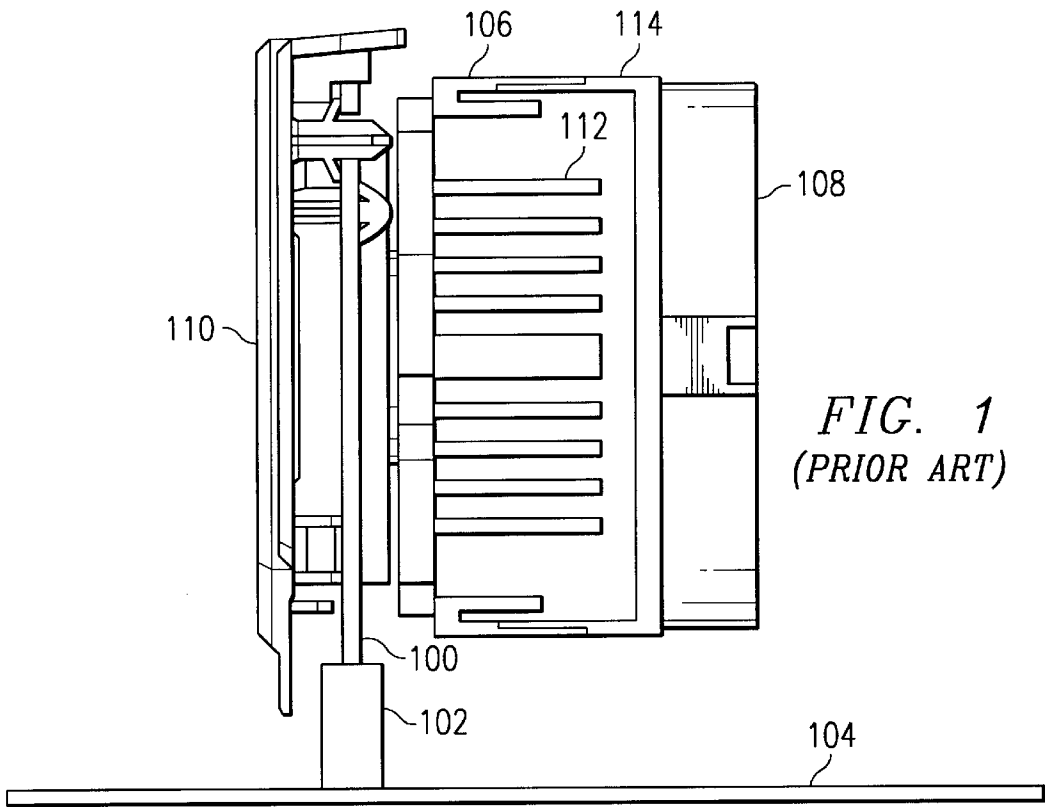

FIG. 1
(PRIOR ART)

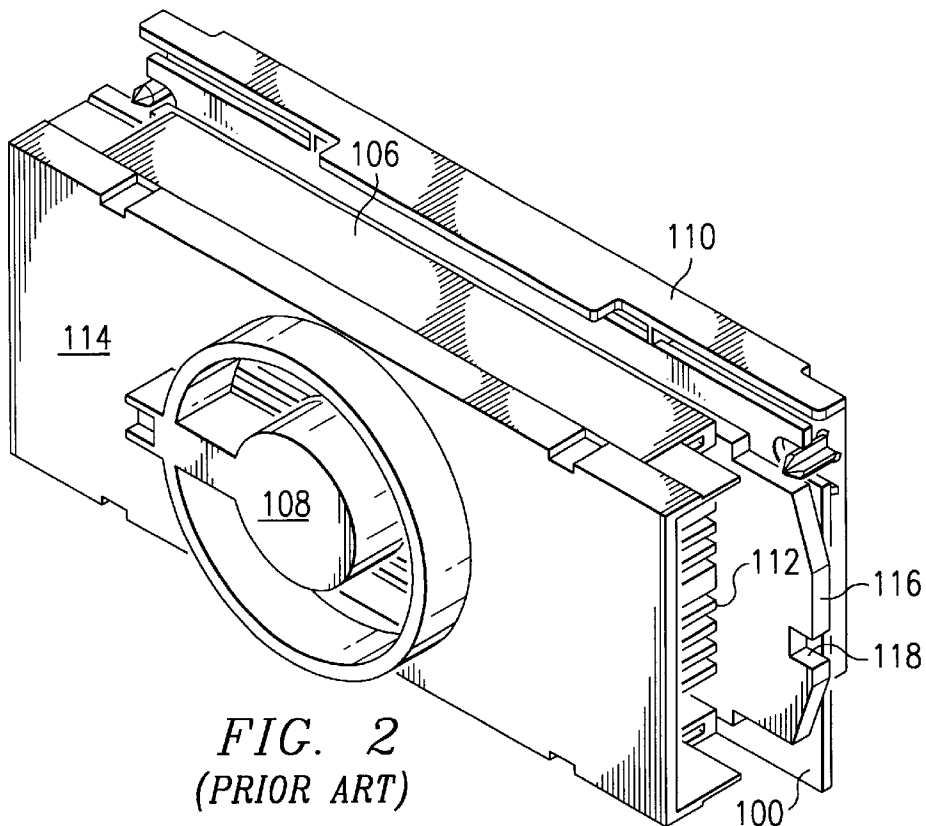

FIG. 2
(PRIOR ART)

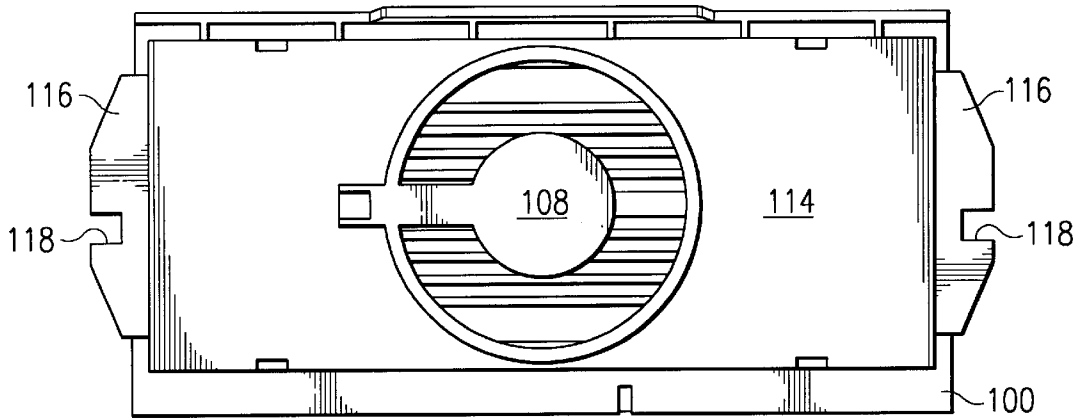

FIG. 3
(PRIOR ART)

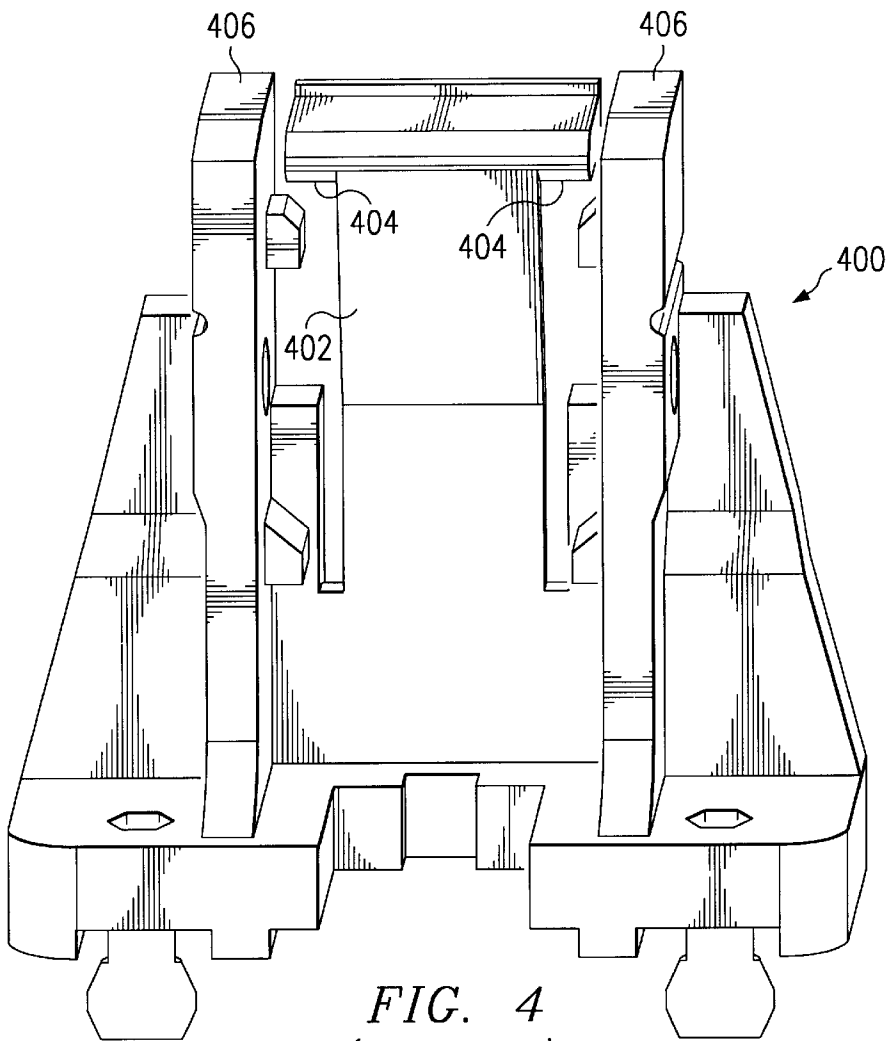
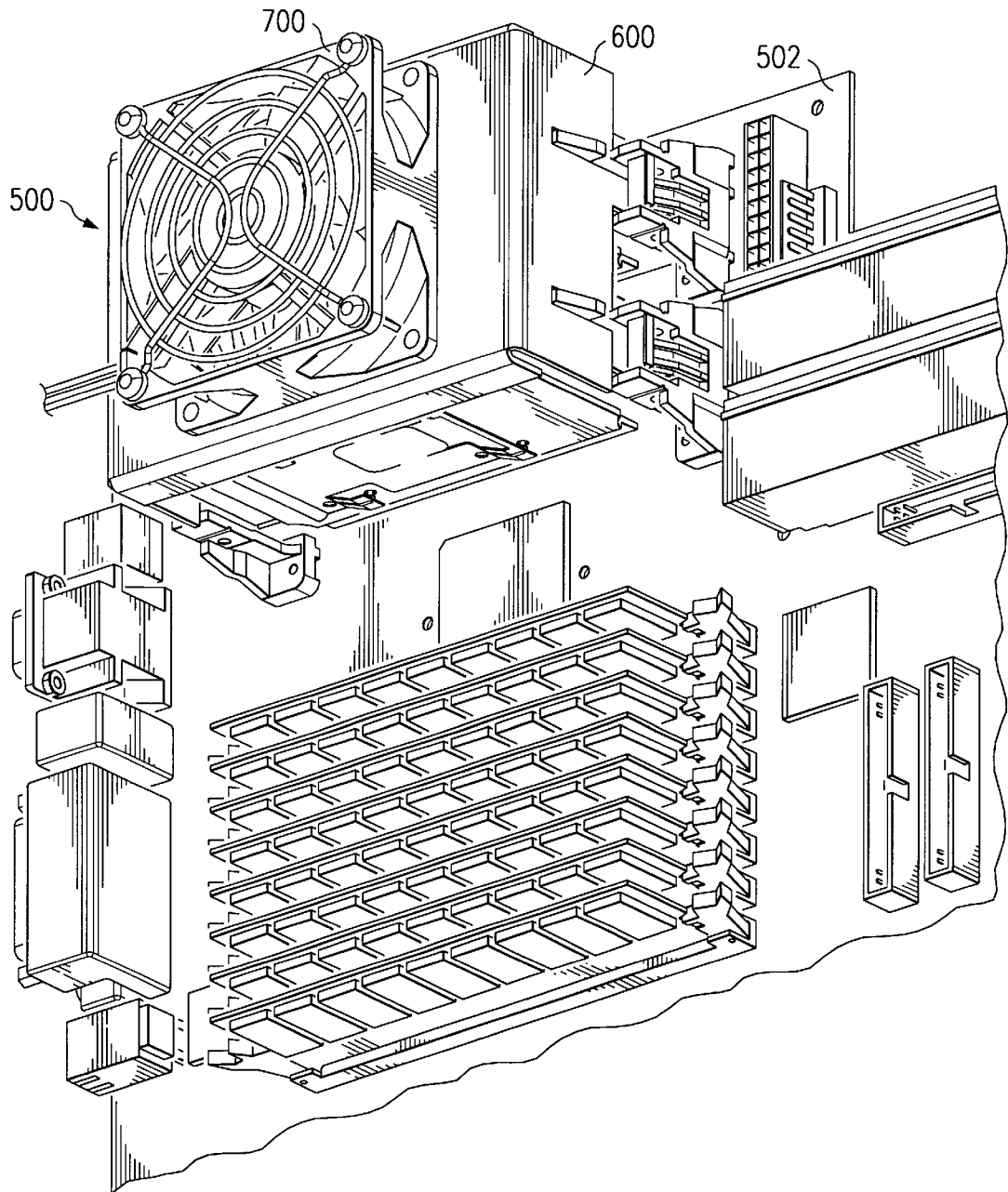
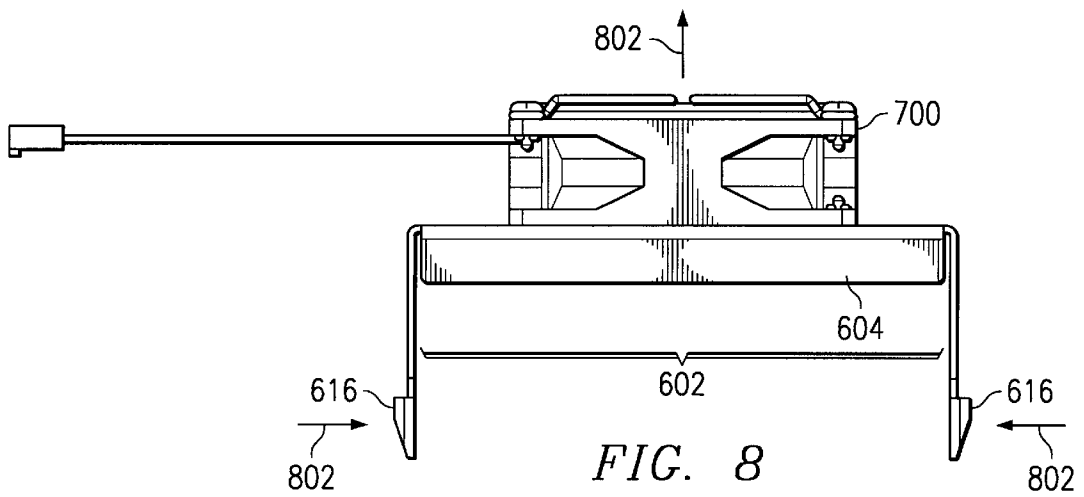
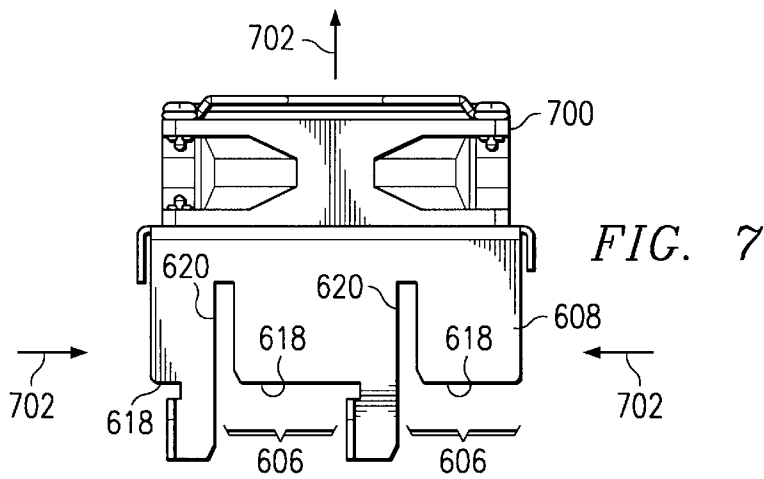
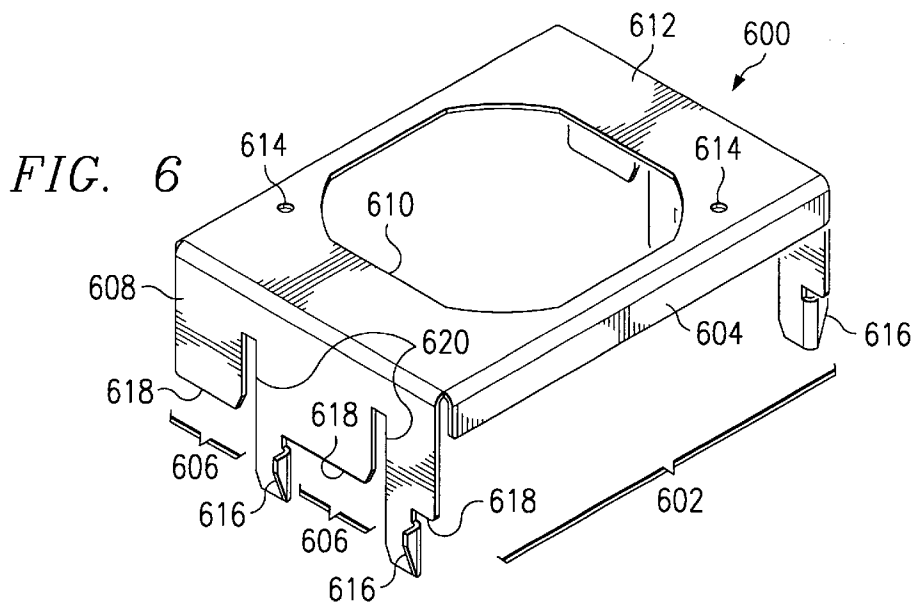

FIG. 4
(PRIOR ART)

FIG. 5





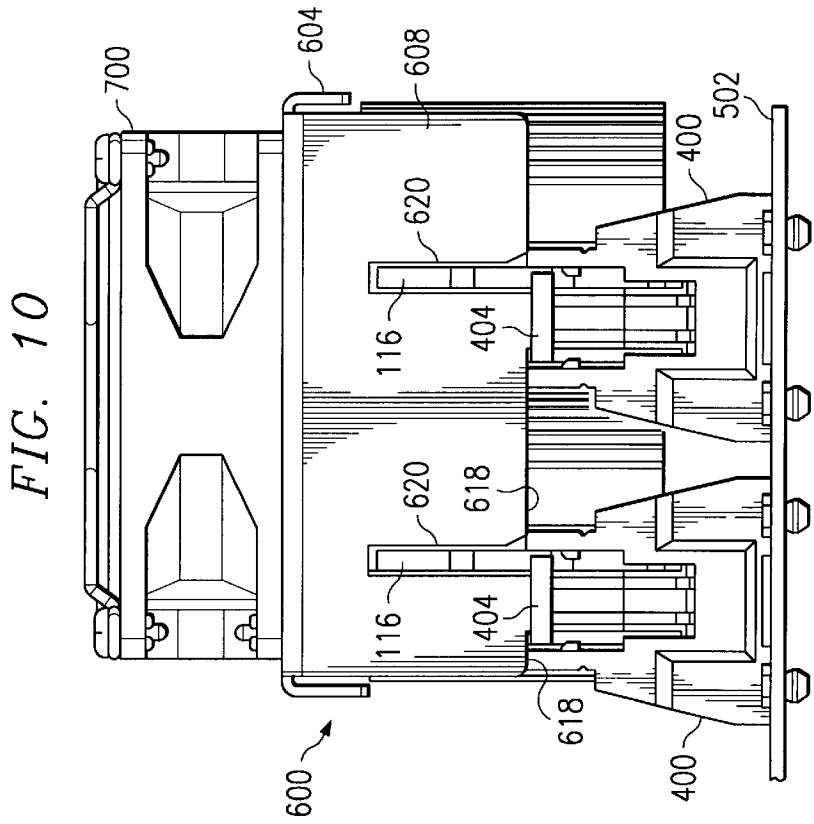
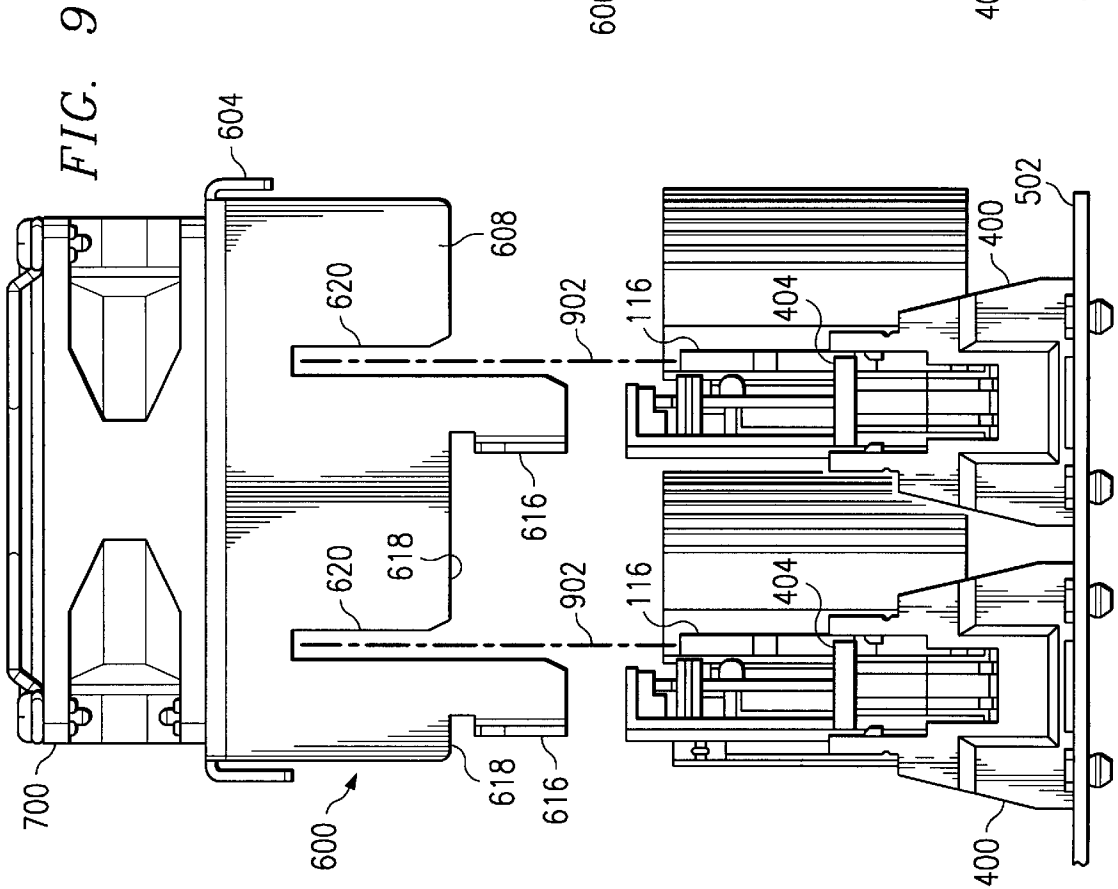

FIG. 11

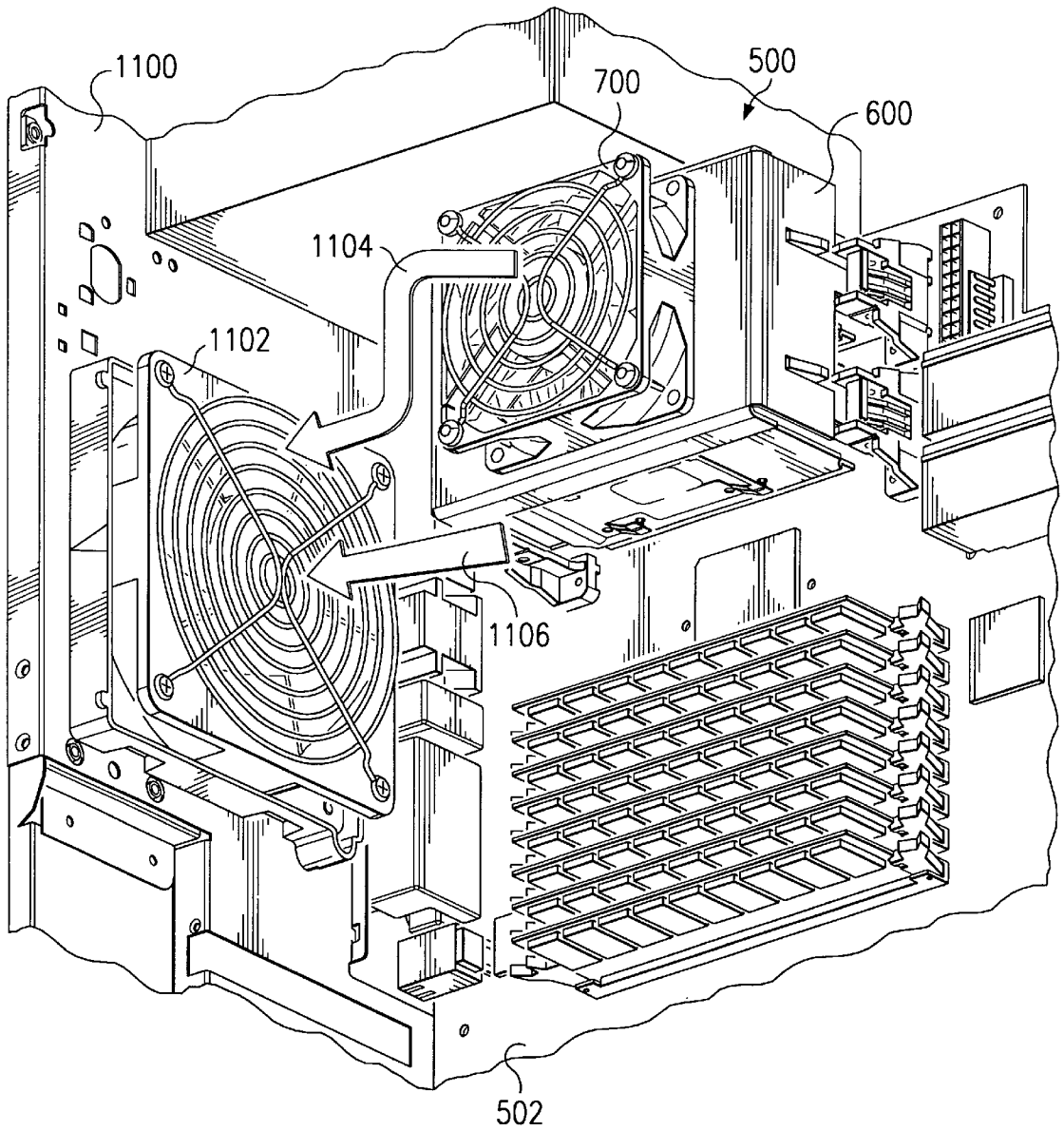

FIG. 13

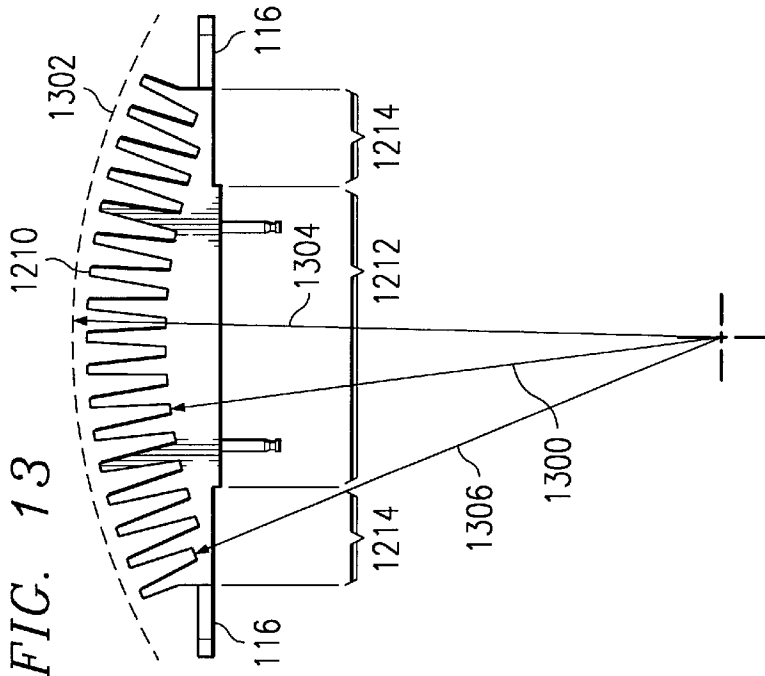

FIG. 14

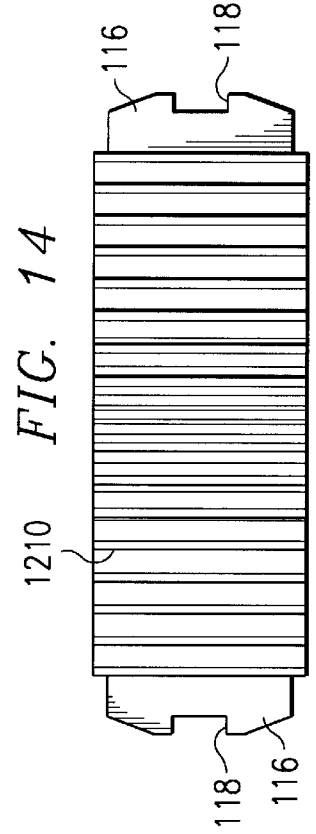

FIG. 12

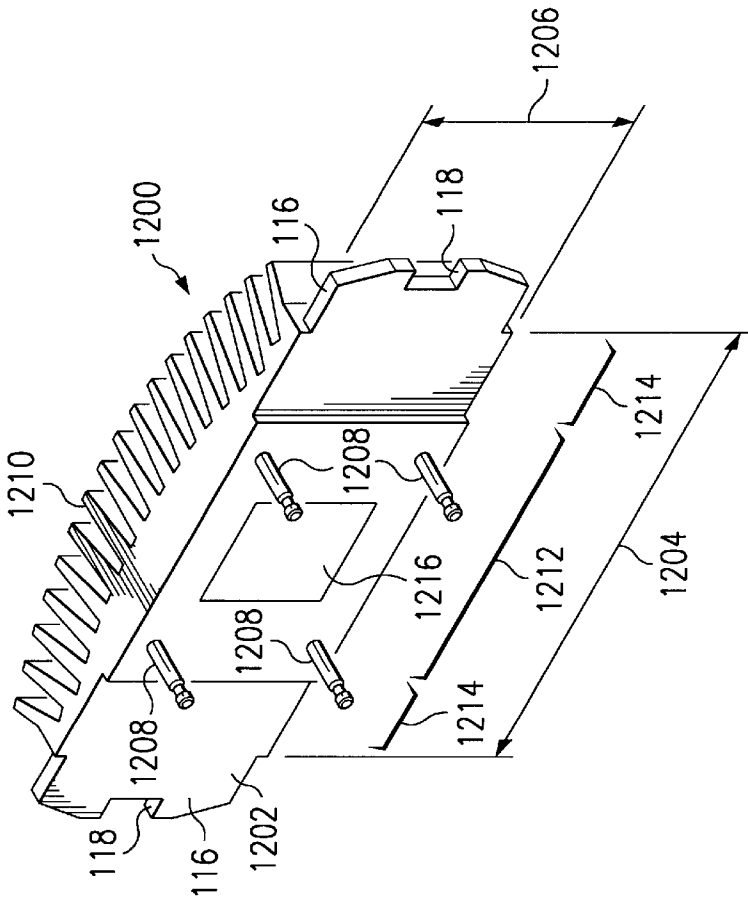

FIG. 15

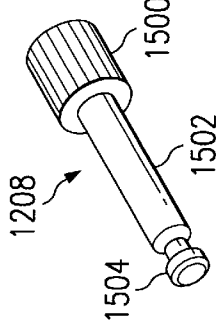

FIG. 16

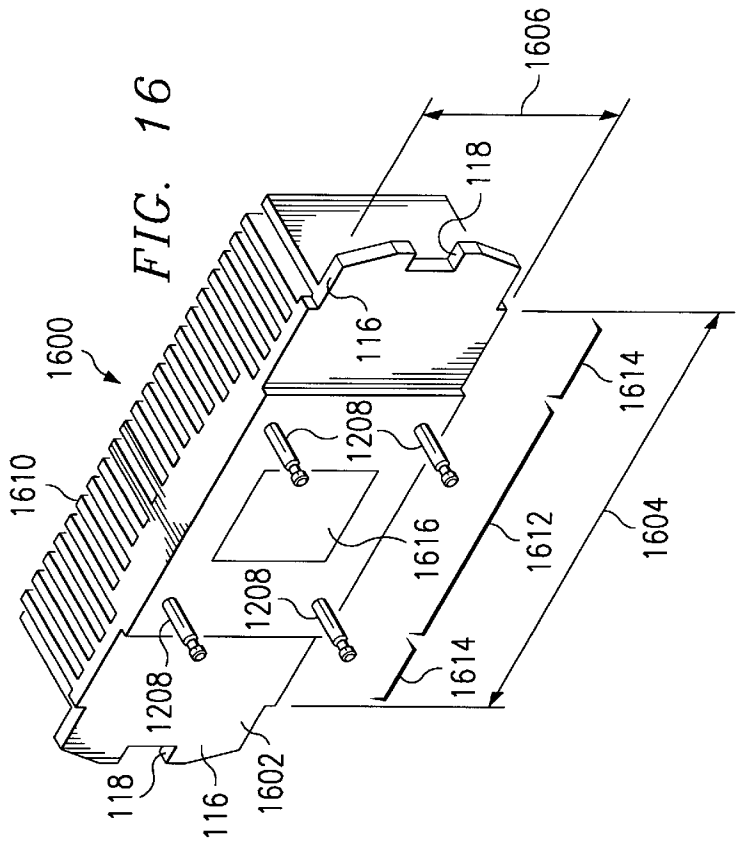

FIG. 17

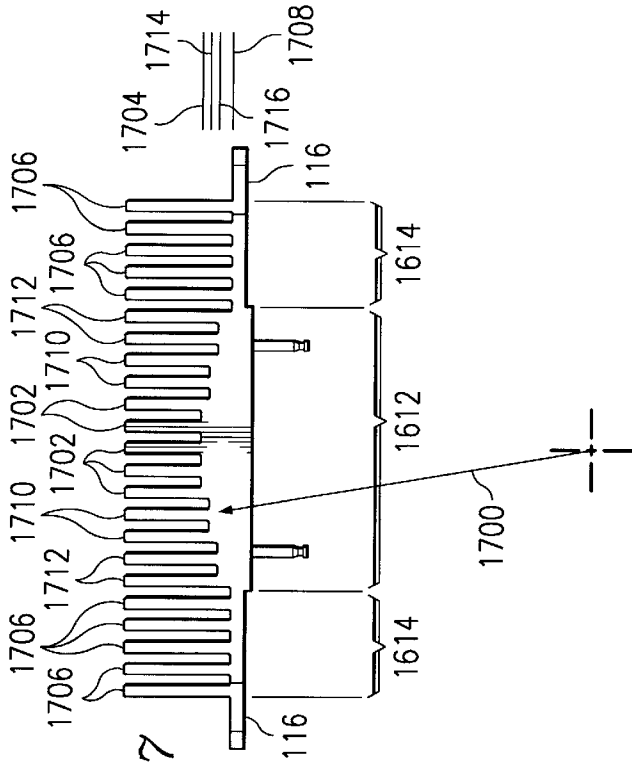
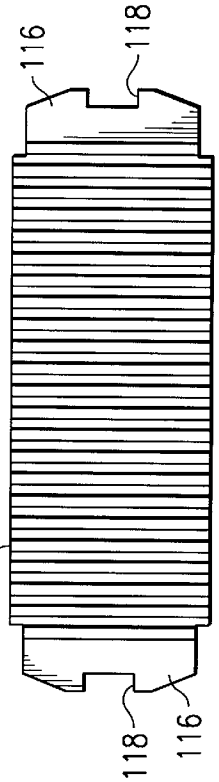

FIG. 18



ACTIVELY COOLED DAUGHTERBOARD SYSTEM

FIELD OF THE INVENTION

This invention relates generally to cooling techniques for electronic circuitry. More particularly, the invention relates to techniques for cooling electronic components that are mounted on a daughterboard.

BACKGROUND

Computer-related electronic systems are commonly constructed using multiple interconnected circuit boards. The largest of these circuit boards is typically called the motherboard. Ancillary circuit boards such as CPU cards, memory cards and input/output cards are typically called daughterboards. Sockets are provided on the motherboard for receiving one or more daughterboards and making appropriate electrical connections between components mounted on the daughterboards and those mounted on the motherboard. Such sockets are usually designed so that the daughterboards may be easily removed and replaced.

Special thermal management problems are presented by motherboard/daughterboard systems wherein high heat dissipation components are mounted on the daughterboards. Specifically, it has been found that fan-driven heat sinks are necessary to prevent the high heat dissipation components such as CPU chips on the daughterboards from overheating.

One example of such a motherboard/daughterboard system is described in the single edge contact cartridge ("SECC") packaging specifications promulgated by Intel Corporation. Referring now to FIG. 1, the packaging specification for boxed SECC2 processors describes a daughterboard 100 on which a CPU is mounted. Daughterboard 100 is adapted to engage a socket 102 on a motherboard 104 so that daughterboard 100 is oriented substantially perpendicular to motherboard 104. A heatsink 106 is disposed on one side of daughterboard 100 between the CPU and a fan 108. On the opposite side of daughterboard 100, an SECC2 cover plate 110 is provided to help anchor heatsink 106 to daughterboard 100. Heatsink 106 is generally rectangular and includes plural elongate fins 112. Each of fins 112 lies on a plane that is substantially parallel to motherboard 104. The axis of rotation of fan 108 is also substantially parallel to motherboard 104. A fan shroud 114 is provided to direct air flow through heatsink 106 from the ends of fins 110 to the middle of fins 110 under fan 108 as shown in FIG. 2.

Heatsink 106 also includes tabs 116 on either end. (Tabs 116 are best illustrated in FIG. 3.) Each of tabs 116 defines a notch 118 for engaging a retaining member of socket 102. An example of such a retaining member is universal retention mechanism 400 ("URM") shown in FIG. 4. URM 400 includes a frame with top surfaces 406 and a resilient arm 402. Resilient arm 402 includes retaining ledges 404. Typically, one URM 400 is disposed on each end of socket 102 with its retaining ledges 404 facing inward toward the socket. When daughterboard 100 is pushed into socket 102, notches 118 on either side of heatsink 106 engage the underside of ledges 404, thereby helping to retain daughterboard 100 in socket 102.

A number of disadvantages are associated with prior art motherboard/daughterboard systems such as those illustrated in FIGS. 1-3. For example, it is frequently necessary to place multiple daughterboards in parallel rows on the same motherboard. Because each prior art daughterboard has a heatsink 106, a shroud 114 and a fan 108 stacked in a direction perpendicular to the plane of the daughterboard,

multiple prior art daughterboards require a large amount of motherboard area. Moreover, systems that require multiple prior art daughterboards are expensive and noisy because each daughterboard in the system includes a noise-producing and relatively expensive fan 108.

It is therefore an object of the invention to provide a daughterboard system that conserves motherboard area when it is necessary to mount more than one daughterboard on the motherboard.

It is a further object to provide such a daughterboard system so that high heat dissipation components such as CPU chips can be mounted on the daughterboard.

It is a still further object to make the daughterboard system less expensive and less noisy than the daughterboard systems of the prior art.

SUMMARY OF THE INVENTION

These and other objects are realized by an actively cooled daughterboard system according to a preferred embodiment of the invention.

In one aspect, one more daughterboards are mounted in parallel rows on a motherboard. Each daughterboard is oriented substantially perpendicular to the motherboard, but may optionally be mounted at an oblique angle relative to the motherboard. Each daughterboard has a low-profile thermally-efficient heatsink mounted thereon. Each heatsink is thermally coupled to one or more heat dissipating electronic components mounted to the respective daughterboard. A fan shroud partially covers the daughterboards, but has openings in its sides for directing air flow through plural fins on the heatsinks and through a fan mounted to the top of the fan shroud. Preferably, the fan is oriented with its axis of rotation substantially parallel to the plural fins of the heatsinks. The inventive daughterboard system enables multiple high heat dissipating daughterboards to be placed closer together than the daughterboard systems of the prior art while still keeping the daughterboards adequately cooled. Moreover, because only a single fan is used to cool all of the daughterboards under the shroud, noise and expense are reduced relative to prior art systems that employed one or more fans per daughterboard.

In another aspect, the fan shroud may include one or more protrusions on each end for engaging retaining ledges housed in retaining members on opposite ends of the daughterboard sockets. In such an embodiment, the fan shroud may also include shoulder surfaces for engaging the tops of the retaining members. The shoulder portions act as insertion stops when the shroud is placed over the daughterboards. Insertion is stopped after the protrusions of the shroud have engaged the retaining ledges on the retaining members. This aspect enables easy removal and replacement of the shroud.

In another aspect, the fan shroud may include one or more guide slots on each end for engaging tabs on the heatsinks as the shroud is placed over the daughterboards. This aspect facilitates proper alignment of the shroud during installation.

In still another aspect, the daughterboard system may be housed in a host computer chassis so that the fan of the daughterboard system has its effluent air path proximate to the intake air path of a chassis ventilation fan. In this manner, heat removal from the daughterboards is further enhanced by the action of the ventilation fan for the host system.

BRIEF DESCRIPTION OF THE DRAWINGS

FIG. 1 is a side view of an actively-cooled daughterboard system according to the prior art.

FIG. 2 is an oblique view of the daughterboard system of FIG. 1.

FIG. 3 is a top plan view of the daughterboard system of FIG. 1.

FIG. 4 is an oblique view of a daughterboard retaining mechanism according to the prior art.

FIG. 5 is an oblique view of an actively cooled daughterboard system according to a preferred embodiment of the invention.

FIGS. 6, 7 and 8 are oblique, side and top plan views, respectively, of the fan shroud of FIG. 5.

FIGS. 9 and 10 are exploded and assembled side views, respectively, of the daughterboard system of FIG. 5.

FIG. 11 is an oblique view of the daughterboard system of FIG. 5 housed in a host computer chassis according to a preferred embodiment of the invention.

FIGS. 12, 13 and 14 are oblique, side and top plan views, respectively, of a first heatsink for optional use with the daughterboard system of FIG. 5.

FIG. 15 is an oblique view of a heatsink mounting pin.

FIGS. 16, 17 and 18 are oblique, side and top plan views, respectively, of a second heatsink for optional use with the daughterboard system of FIG. 5.

DETAILED DESCRIPTION OF THE PREFERRED EMBODIMENTS

Actively cooled daughterboard system. FIG. 5 illustrates an actively cooled daughterboard system 500 according to a preferred embodiment of the invention. In daughterboard system 500, one or more daughterboards are housed inside a fan shroud 600. (In the embodiment shown, two daughterboards are so housed.) Each daughterboard housed within shroud 600 has a heat generating component such as a CPU mounted on it, and each daughterboard assembly includes a heatsink that is thermally coupled to the heat generating component. Preferably, each heatsink includes a plurality of transverse fins (to be further described below) oriented so that air may pass between the fins in a direction generally parallel to the plane of the associated daughterboard. Active cooling is provided by a single fan 700 mounted on the top of shroud 600 as shown. Using a single fan in this manner eliminates the need for multiple fans located on the individual daughterboard assemblies.

Fan shroud 600 is illustrated in more detail in FIGS. 6-8. Fan shroud 600 has openings 602 in both sides 604 and openings 606 in both ends 608. In addition, there is an opening 610 in top surface 612 underneath the footprint of fan 700. The purpose of openings 602, 604 and 610 is to direct air flow through the plural transverse fins of the heatsinks and through fan 700. Preferably, fan 700 is mounted on shroud 600 as shown in FIGS. 7 and 8 so that the axis of rotation of fan 700 is substantially parallel with planes of the daughterboards (and thus also parallel with the outer ends of the transverse fins of the heatsinks). When fan 700 is so oriented, air flow will occur generally in the direction indicated by arrows 702 (side intake, top effluent) and 802 (end intake, top effluent). In alternative embodiments, the direction of the airflow may be reversed by changing the blow direction of fan 700.

In the embodiment shown, fan shroud 600 was constructed from a single sheet of aluminum alloy which was cut and then folded into the configuration shown. Alternative materials and construction methods may, of course, be employed. Fan 700 was mounted to the top of shroud 600 by inserting plastic rivets in mounting holes 614. Alternative mounting methods may be used.

It is a feature of the invention that shroud 600 includes protrusions 616 on each end 608 for engaging retaining ledges 404 of retaining members 400. In addition, shroud 600 also includes shoulder portions 618 which act as insertion stops when shroud 600 is placed over the tops of the daughterboards. (Shoulder portions 618 engage the top surface of retaining members 400 to stop the movement of shroud 600 toward motherboard 502 as shroud 600 is being placed over the daughterboards.) Preferably, protrusions 616 should be disposed below shoulder portions 618 by a distance that will allow them to engage the undersides of retaining ledges 404 just before shoulders 618 contact the top surfaces of retaining members 400. In an embodiment, ends 608 were separated by a distance that was slightly smaller than the distance between retaining members 400. Such a spacing was adequate to enable protrusions 616 to engage retaining ledges 404 when shroud 600 was placed over the daughterboards.

It is an additional feature of the invention that shroud 600 includes guide slots 620 on each end 608. Each of the heatsinks on the daughterboards includes end tabs 116. After the daughterboards have been installed into their sockets on motherboard 502 as shown in FIG. 9, notches 118 in end tabs 116 engage retaining ledges 404 on one end of ledges 404, leaving the other end of retaining ledges 404 free. Guide slots 620 are used to properly align shroud 600 over tabs 116 for installation as indicated by dashed lines 902. When slots 620 are disposed over tabs 116, protrusions 616 align themselves with the free end of retaining ledges 404. Shroud 600 is lowered into position until protrusions 616 engage the free end of retaining ledges 404 as shown in FIG. 10. It can be seen in FIG. 10 that shoulder portions 618 on shroud ends 608 act as insertion stops when they engage the top surfaces of retaining members 400.

Additional heat removal efficiency may be achieved by mounting daughterboard system 500 in a host computer chassis 1100 as shown in FIG. 11. In the configuration of FIG. 11, the effluent path 1104 of fan 700 is proximate to the intake path 1106 of a chassis ventilation fan 1102. This enables chassis fan 1102 to direct heat-containing effluent from daughterboard system 500 to the exterior of chassis 1100.

First preferred heatsink. A first preferred heatsink for optional use with daughterboard system 500 will now be described with reference to FIGS. 12-14. Heatsink 1200 was extruded using an aluminum 6063-T5 material. Other materials and fabrication techniques may be used. Heatsink 1200 includes a rectangular base portion 1202 having a longitudinal dimension 1204 longer than its transverse dimension 1206. Tabs 116 were cut on either end of the base portion, for engaging retaining members 400 disposed proximate to a socket of a motherboard 502. Four holes were drilled into the bottom of base portion 1202 for receiving mounting pins 1208 for anchoring heatsink 1200 to a daughterboard. Numerous transverse fins 1210 were integrally formed with base portion 1202 during extrusion. Fins 1210 were radially displaced from one another, as shown.

Base portion 1202 has end parts 1214 and a central part 1212. Central part 1212 is preferably disposed directly over the heat generating component(s) of the daughterboard, and is thicker than end parts 1214 to enhance heat removal effectiveness over the components. In the illustrated embodiment, the thickness of central part 1212 of base portion 1202 varies according to an inner radius 1300 of fins 1210. In one embodiment, inner radius 1300 was approximately 119.2 mm. The profile 1302 formed by the outer ends of fins 1210 varies according to an outer radius 1304. In one

embodiment, outer radius **1304** was approximately 136.8 mm and was constant for each of fins **1210**. The inner radius, however, was not constant for each of fins **1210**. Specifically, inner radius **1306** (associated with the fins coupled to end parts **1214** of base portion **1202**) was slightly longer than inner radius **1300** (associated with the fins coupled to central part **1212** of base portion **1202**). Variation of the inner fin radius in this manner enables additional fins to be placed on heatsink **1200** while maintaining a constant outer radius **1302**.

Preferably, central part **1212** of base portion **1202** is adapted to be coupled to the a heat generating component of the daughterboard. In one embodiment, this was accomplished by attaching a thermally conductive aluminum foil to the central area **1216** of the bottom of base **1202**. One material that was found to be useful for this purpose is sold under the trademark THERMSTRATE, and is available from Foxcon, Inc. under the part number 081-0001-558.

Mounting pins **1208** are illustrated in more detail in FIG. **15**. Each pin **1208** has a stem **1502** with a knurled cylindrical portion **1500** on one end and a clip retaining lip **1504** on the other end. During assembly, knurled portion **1500** is pressed into the previously-drilled receiving holes on the bottom of base **1202** of heatsink **1200** forming a friction fit. Clip retaining lips **1504** are used to secure heatsink **1200** to the daughterboard by means of a retaining clip. Retaining clips useful for this purpose are available from Foxcon, Inc. under the part number 025-0002-960. Other means may optionally be used to secure heatsink **1200** to the daughterboard.

Second preferred heatsink. A second preferred heatsink **1600** for optional use with daughterboard system **500** will now be described with reference to FIGS. **16–18**. Heatsink **1600** was extruded using the same material as heatsink **1200**. Other materials and fabrication techniques may be used. Heatsink **1600** includes a rectangular base portion **1602** having a longitudinal dimension **1604** longer than its transverse dimension **1606**. Tabs **116** were cut on either end of the base portion, for engaging retaining members **400** disposed proximate to a socket of a motherboard **502**. Four holes were drilled into the bottom of base portion **1602** for receiving mounting pins **1208** for anchoring heatsink **1600** to a daughterboard. Numerous transverse fins **1610** were integrally formed with base portion **1602** during extrusion. Fins **1610** are all parallel to each other and orthogonal to the bottom of base portion **1602**.

Base portion **1602** has end parts **1614** and a central part **1612**. The central part **1612** is thicker than the end parts **1614** to enhance heat removal over the heat generating components of the daughterboard. The thickness of central part **1612** of base portion **1602** varies according to a radius **1700**. Radius **1700** may be approximated by step differences in the depths of fins **1610**. For example, in the embodiment shown, five central fins **1702** are the shallowest depth **1704**. Two groups of five endmost fins **1706** have the deepest depth **1708**. And fin pairs **1710**, **1712** have intermediate depths **1714**, **1716**, respectively. The profile formed by the outer ends of fins **1710** is constant relative to the bottom of the base portion **1602**.

Like heatsink **1200**, heatsink **1600** is preferably adapted to be coupled to a heat generating component of the daughterboard by attaching thermally conductive aluminum foil to the bottom of base **1602** in central area **1616**. Also like heatsink **1200**, pins **1208** may be used to secure heatsink **1600** to the daughterboard.

While the invention has been described in detail in relation to a preferred embodiment thereof, the described

embodiment has been presented by way of example and not by way of limitation. It will be understood by those skilled in the art that various changes may be made in the form and details of the described embodiment without deviating from the spirit and scope of the invention as defined by the appended claims.

What is claimed is:

1. An actively cooled daughterboard system, comprising:
 - a daughterboard having a heat generating component mounted thereon;
 - a heatsink thermally coupled to the component and having plural transverse fins; and
 - a fan shroud disposed over the daughterboard, the fan shroud having a fan mounted therein and having openings for directing air flow through the plural transverse fins of the heatsink and through the fan; wherein the daughterboard is engaged with a socket on a motherboard, the socket having retaining members disposed on each of its ends, each retaining member having a retaining ledge thereon facing inward toward the socket; and
 - the fan shroud has at least one protrusion on each end for engaging the retaining ledges when the fan shroud is placed over the daughterboard.
2. A daughterboard system according to claim 1, wherein: the fan shroud further includes shoulder portions on each end for engaging the tops of the retaining members and acting as insertion stops when the fan shroud is placed over the daughterboard.
3. A daughterboard system according to claim 1, wherein: the fan shroud includes at least one guide slot on each end for engaging tabs disposed on the ends of the heatsink, the guide slots for facilitating proper alignment when the fan shroud is placed over the daughterboard.
4. A daughterboard system according to claim 1, wherein: at least one of the openings is located on the end of the fan shroud between the motherboard and the shoulder portions.
5. A daughterboard system according to claim 1, wherein: at least one of the openings is located on the side of the fan shroud between the motherboard and the shoulder portions.
6. A daughterboard system according to claim 1, wherein: at least one of the openings is located on the end of the fan shroud between the motherboard and the shoulder portions; and
- at least one of the openings is located on the side of the fan shroud between the motherboard and the shoulder portions.
7. An actively cooled daughterboard system, comprising:
 - a daughterboard having a heat generating component mounted thereon;
 - a heatsink thermally coupled to the component and having plural transverse fins; and
 - a fan shroud disposed over the daughterboard, the fan shroud having a fan mounted therein and having openings for directing air flow through the plural transverse fins of the heatsink and through the fan;
 wherein the fan shroud includes at least one guide slot on each end for engaging tabs disposed on the ends of the heatsink, the guide slots for facilitating proper alignment when the fan shroud is placed over the daughterboard.
8. A daughterboard system according to claim 7, wherein: the daughterboard is engaged with a socket on a motherboard, the socket having retaining members

7

disposed on each of its ends, each retaining member having a retaining ledge thereon facing inward toward the socket; and

the fan shroud has at least one protrusion on each end for engaging the retaining ledges when the fan shroud is placed over the daughterboard. 5

9. A daughterboard system according to claim 7, wherein: the fan shroud further includes shoulder portions on each end for engaging the tops of the retaining members and acting as insertion stops when the fan shroud is placed over the daughterboard. 10

10. A daughterboard system according to claim 7, wherein: at least one of the openings is located on the end of the fan shroud between the motherboard and the shoulder portions. 15

8

11. A daughterboard system according to claim 7, wherein:

at least one of the openings is located on the side of the fan shroud between the motherboard and the shoulder portions.

12. A daughterboard system according to claim 7, wherein:

at least one of the openings is located on the end of the fan shroud between the motherboard and the shoulder portions; and

at least one of the openings is located on the side of the fan shroud between the motherboard and the shoulder portions.

* * * * *