

(No Model.)

3 Sheets—Sheet 1.

A. E. TREVITHICK.  
STREET CLEARING APPARATUS.

No. 525,635.

Patented Sept. 4, 1894.

— Fig. 1 —

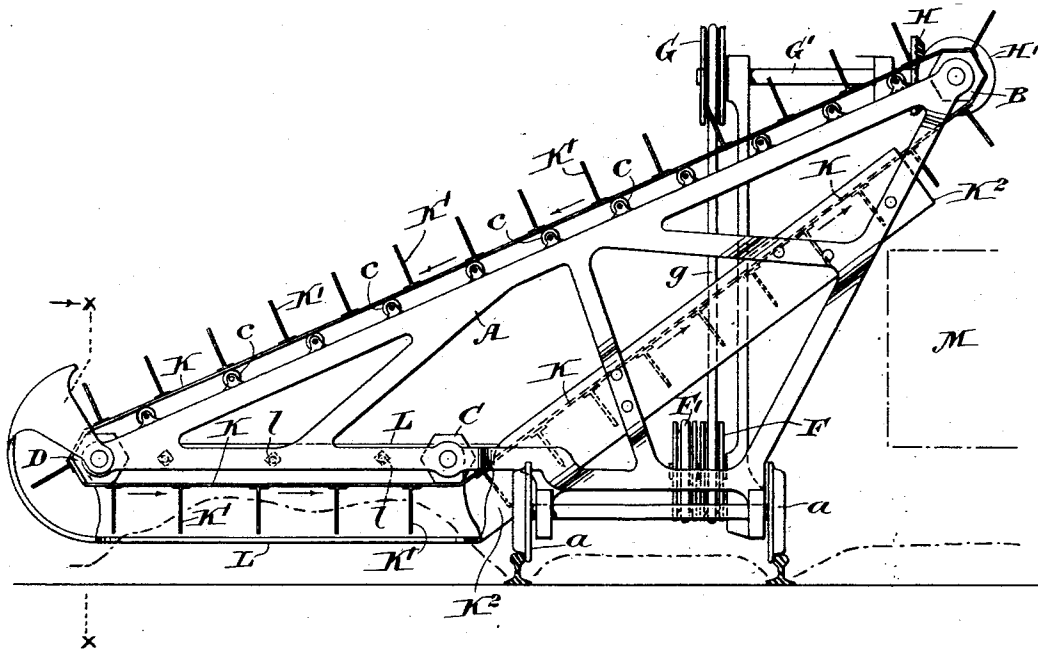

Witnesses

*[Handwritten signature]*

*R. B. Spitzer*

Inventor

*Alfred E. Trevithick*

By his Attorney

*Russell Lyman*

(No Model.)

3 Sheets—Sheet 2.

# A. E. TREVITHICK. STREET CLEARING APPARATUS.

No. 525,635.

Patented Sept. 4, 1894.

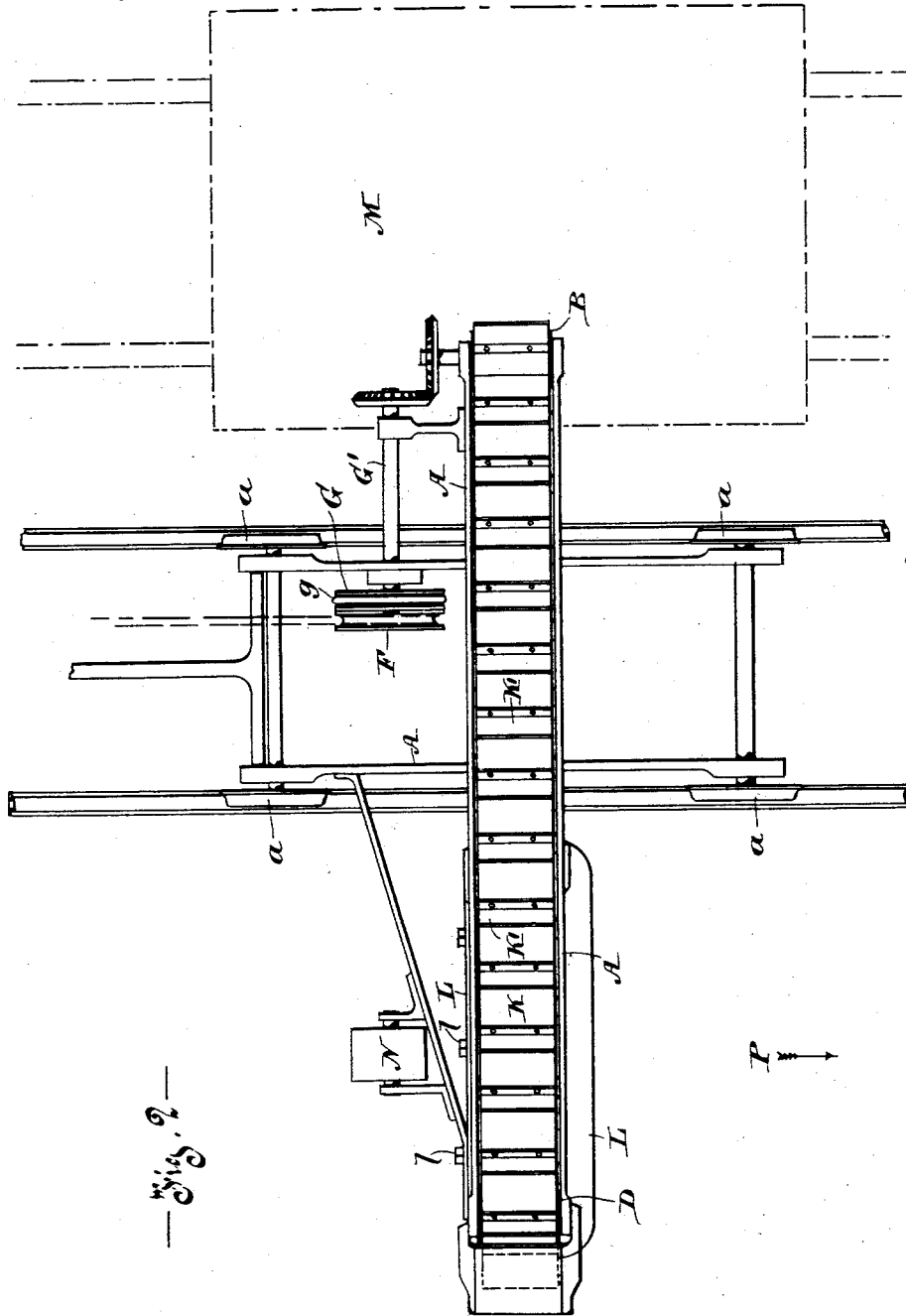

Fig. 2

Witnesses

*Wm. H. ...*

*R. W. ...*

Inventor

*Alfred E. Trevithick*

By *his* Attorney

*Trusty Reynolds*

(No Model.)

3 Sheets—Sheet 3.

A. E. TREVITHICK.  
STREET CLEARING APPARATUS.

No. 525,635.

Patented Sept. 4, 1894.

Fig. 3

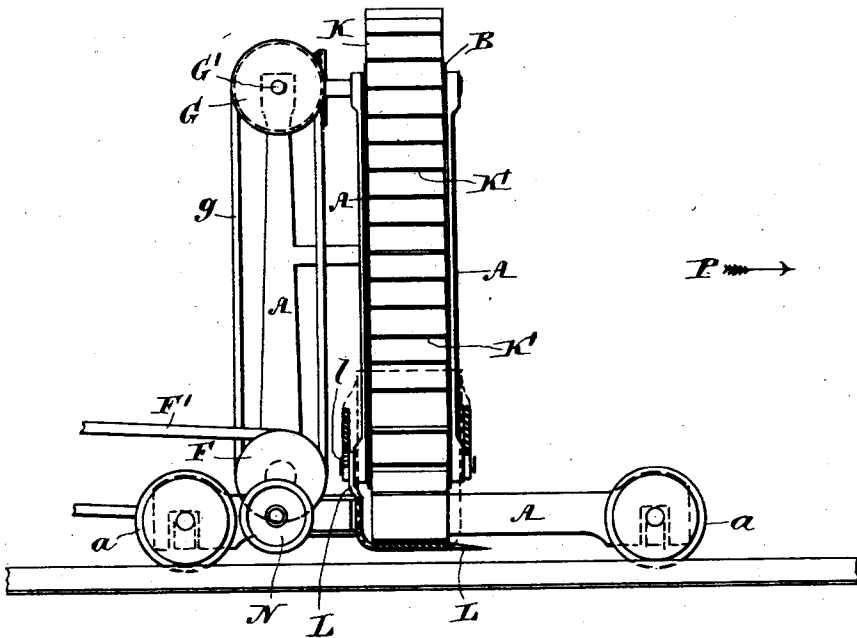

Witnesses

*[Signature]*

R. W. Stinson

Inventor

Alfred C. Trevithick

By his Attorney

*[Signature]*

# UNITED STATES PATENT OFFICE.

ALFRED EWART TREVITHICK, OF ST. HENRI, CANADA.

## STREET-CLEARING APPARATUS.

SPECIFICATION forming part of Letters Patent No. 525,635, dated September 4, 1894.

Application filed February 27, 1894. Serial No. 501,742. (No model.)

*To all whom it may concern:*

Be it known that I, ALFRED EWART TREVITHICK, of St. Henri, in the county of Hochelaga and Province of Quebec, Canada, have invented certain new and useful Improvements in Street-Clearing Apparatus; and I do hereby declare that the following is a full, clear, and exact description of the same.

This invention which is specially adapted for clearing snow from streets on which a double line of cars runs has for its object to cut away and raise by mechanical means the surface snow to the depth required and deliver it into suitable receptacles in which it can be moved away to the dumping ground thus doing away with the necessity of shoveling by hand.

The invention may be described as consisting of an automatic gathering and lifting mechanism mounted on wheels and adapted to be propelled or drawn along one of the lines of tracks on the street by either the track clearer or "sweeper" with which it may work or any special motor (usually electrical) either of which will furnish in addition the power necessary to operate the mechanism, and by the operation of which the snow is gathered, lifted and deposited into suitable receptacles traveling on the adjacent line of tracks.

The apparatus may be briefly described as consisting of a carriage and framing mounted on wheels running on one of the lines of tracks and being propelled or drawn either by the usual "sweeper" with which it may work, or any special motor as before mentioned. Upon this framing is carried on suitable rollers a traveling conveyer formed of a platform or endless chain one end of which projects a suitable distance over the roadway, and is supported in such position by proper extensions from the frame. This platform or endless chain which has secured upon it, at suitable distances apart, ribs or projections of desired depth, travels obliquely downward from its operating roller situated at the highest part of the frame which is the end that projects over the receptacle for the snow

to the extreme opposite end that extends over the other side of the roadway, then horizontally inward to a point near the carrying frame and then obliquely upward to the end above the receptacle.

Under the horizontally moving portion of the platform or endless chain is secured a scoop adjustable as to height which serves to cut off the surface snow and direct it into the spaces between the ribs on the platform as it moves to the point of discharge.

The operating roller is driven by any suitable system of pulleys, belts and gearing.

The receptacles for the snow may be either attached to the traveling truck and taken away separately when filled or they may be moved by any distinct motor.

For full comprehension of the invention, reference must be had to the annexed drawings forming part of this specification in which like symbols denote the same parts and where Figure 1 is a front view; Fig. 2 a plan view; and Fig. 3 a side view of the apparatus.

A is the traveling frame or carriage mounted on wheels *a a* as shown and running on one of the lines of track, the means for its propulsion not being shown as it forms no part of the invention. The frame is constructed as shown or in any suitable way so as to afford points of support for the spindle ends of the operating roller B and those of the rollers C, D, all of which rollers are of octagonal or any other usual form and have the necessary lug projections to intersect with the chain or platform. Auxiliary plain rollers *c c* may also be used to facilitate the movement of the platform.

F is a sheave mounted on a stub axle *f* projecting from the frame and driven through a belting indicated at *F'* by the motive power, whatever it may be. From this sheave a belt *g* is taken to a pulley G mounted on a counter shaft G' carried at the upper end of the frame and this shaft through beveled pinions H H' rotates the operating roller B.

K is the endless traveling platform and K' the transverse ribs or projections formed in any desired way or secured to same.

K<sup>2</sup> is an inclosing casing through which the platform preferably moves after traveling horizontally and being filled with snow.

L is the plate or scoop, for gathering the snow, formed preferably as shown, and attached adjustably as to height to the frame A by bolts *ll* or in any other suitable way.

M indicates the receptacle into which the snow falls from the traveling platform. This may run on the other line of track or in the case of single track, be drawn alongside the machine.

N is a roller which is carried in rear of the lower projecting portion of the frame and is adapted to act as a support in case of excessive tilting of the apparatus to this side.

In operation, the apparatus is continuously moved forward in the direction indicated by arrow P the scoop gathers in the snow and as the conveying platform is always moving in a lateral direction over the scoop preferably in the direction indicated, the snow gathered is carried up through the casing K<sup>2</sup> and delivered into the receptacle or the platform might travel in an opposite direction if so desired.

What I claim is as follows:

1. In a street clearing apparatus, a supporting carriage and a framing projecting on each side of the carriage one projecting portion being in close proximity to the roadway and the other extending upward; and the whole adapted to be moved along the roadway, a gathering section or scoop located beneath the projecting portion on the lower level, and an endless traveling conveyer moving trans-

versely of the apparatus across such gathering section and in an upward direction with means for driving such conveyer.

2. In a street clearing apparatus, a supporting carriage and a framing projecting on each side of the carriage one projecting portion being in close proximity to the roadway and the other extending upward; and the whole adapted to be moved along the roadway, a gathering section or scoop located beneath the projecting portion on the lower level, and an endless traveling conveyer moving transversely of the apparatus across such gathering section and in an upward direction with means for driving such conveyer and retaining the substance in same when traveling in the upward direction.

3. In a street clearing apparatus, a supporting carriage and a framing projecting on each side of the carriage one projecting portion being in close proximity to the roadway and the other extending upward, and the whole adapted to be moved along the roadway; an adjustable gathering section or scoop located beneath the projecting portion on the lower level, an endless traveling conveyer moving transversely of the apparatus across such gathering section and in an upward direction, an inclosing casing for such conveyer when it travels in said upward direction and means for driving such conveyer.

Montreal, 10th day of February, 1894.

ALFRED EWART TREVITHICK.

In presence of—

FRED. J. SEAR,

WILL P. MCFEAT.