



US00D678993S

(12) **United States Design Patent**
Kung-Hua

(10) **Patent No.:** **US D678,993 S**

(45) **Date of Patent:** **** Mar. 26, 2013**

- (54) **BLADELESS HAND HELD FAN**
- (75) Inventor: **Lin Kung-Hua**, Chung-Ho (TW)
- (73) Assignee: **Cute Item Industries, Ltd.**, Chung-Ho, Taipei (TW)
- (**) Term: **14 Years**
- (21) Appl. No.: **29/410,362**
- (22) Filed: **Jan. 6, 2012**
- (51) **LOC (9) Cl.** **23-04**
- (52) **U.S. Cl.** **D23/370**
- (58) **Field of Classification Search** D23/213, D23/223, 228, 328, 332, 355, 356, 370, 386, D23/411; D9/530, 682, 685, 719; 239/29, 239/215, 289; 261/28, 115, 116; 416/146 R, 416/5; 415/90, 182.1, 211.2, 126; 417/84
See application file for complete search history.

D553,227 S *	10/2007	Chen	D23/328
D602,143 S *	10/2009	Gammack et al.	D23/370
7,806,388 B2 *	10/2010	Junkel et al.	261/28
7,972,111 B2 *	7/2011	Crawford et al.	415/211.2
8,016,270 B2 *	9/2011	Chen et al.	261/28
8,052,379 B2 *	11/2011	Gammack	415/126
2009/0060710 A1 *	3/2009	Gammack et al.	415/90
2010/0225012 A1 *	9/2010	Fitton et al.	261/116
2010/0254800 A1 *	10/2010	Fitton et al.	415/90

* cited by examiner

Primary Examiner — Janice Seeger

Assistant Examiner — Martie K Holtje

(74) *Attorney, Agent, or Firm* — Rabin & Berdo, P.C.

(57) **CLAIM**

The ornamental design for a bladeless hand held fan, as shown and described.

DESCRIPTION

FIG. 1 is a perspective view showing the new design;
 FIG. 2 is a front elevational view thereof;
 FIG. 3 is a rear elevational view thereof;
 FIG. 4 is a left side elevational view thereof;
 FIG. 5 is a right side elevational view thereof;
 FIG. 6 is a top plan view thereof; and,
 FIG. 7 is a bottom plan view thereof.

The broken lines depicting various structural elements in the figures are included for the purpose of illustrating portions of the article that form no part of the claimed design.

1 Claim, 4 Drawing Sheets

(56) **References Cited**

U.S. PATENT DOCUMENTS

D54,419 S *	2/1920	Hotz	D23/370
1,504,003 A *	8/1924	Trumbull	416/5
4,839,106 A *	6/1989	Steiner	261/28
5,667,732 A *	9/1997	Lederer	261/28
5,837,167 A *	11/1998	Lederer	261/28
D457,613 S *	5/2002	Schaefer	D23/328
D529,166 S *	9/2006	Geringer	D23/379
D544,078 S *	6/2007	Geringer	D23/328

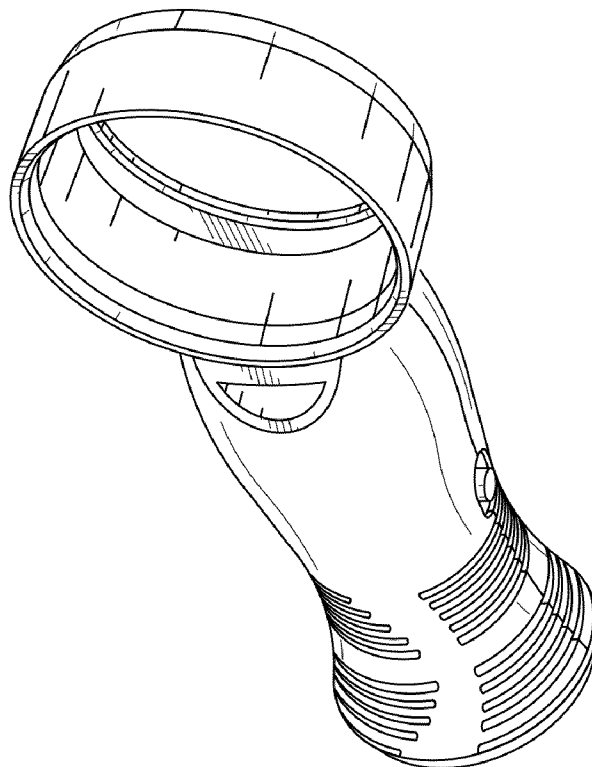

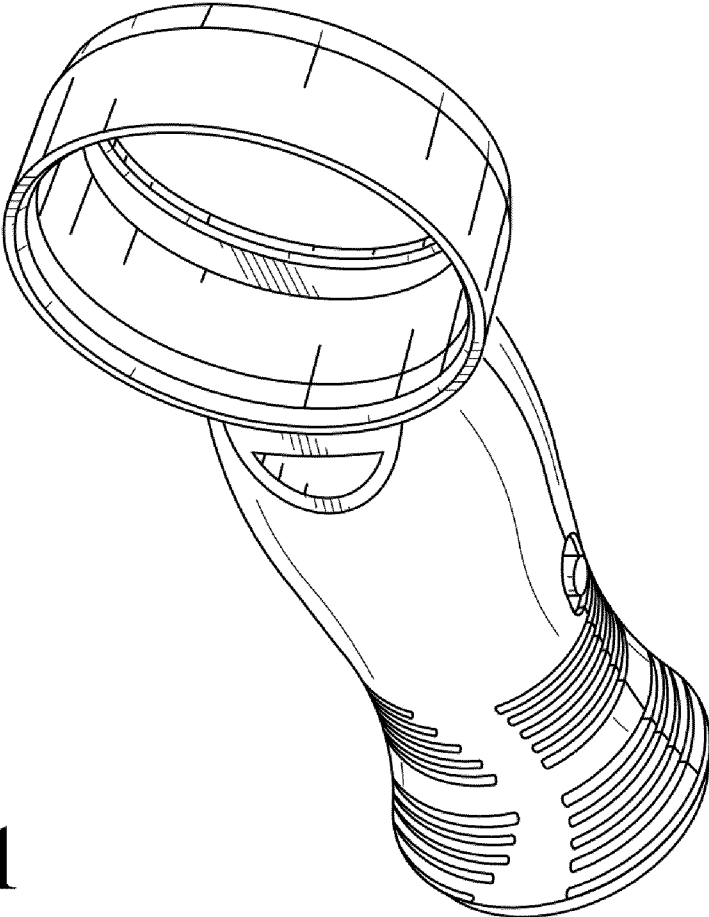

FIG. 1

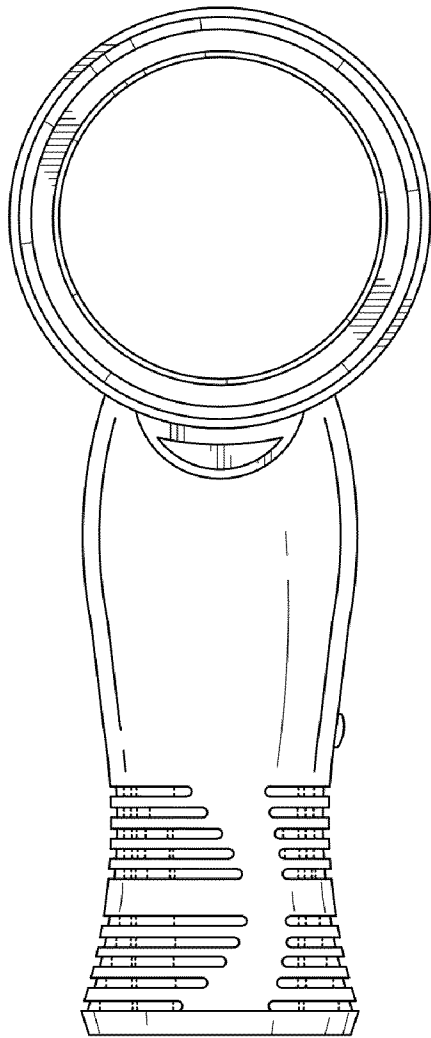

FIG. 2

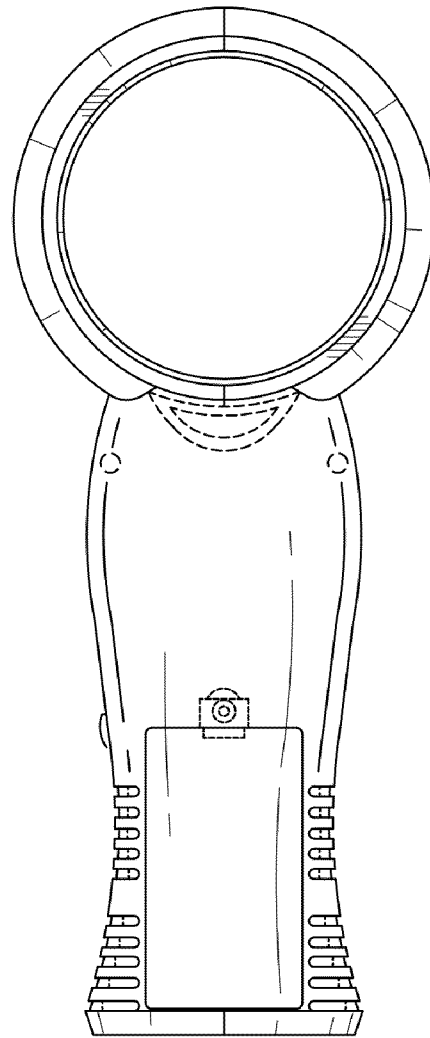

FIG. 3

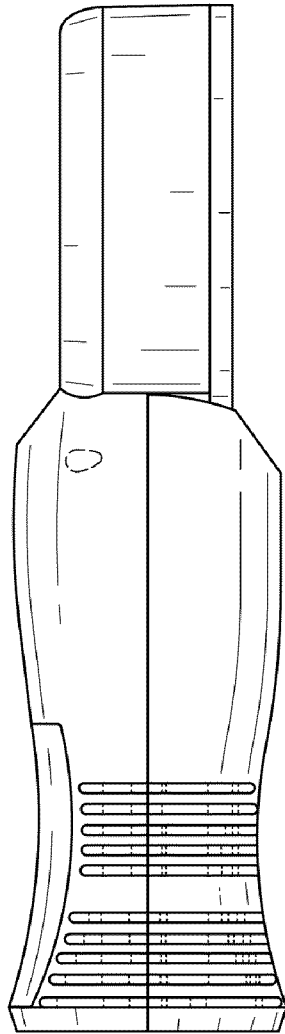

FIG. 4



FIG. 5

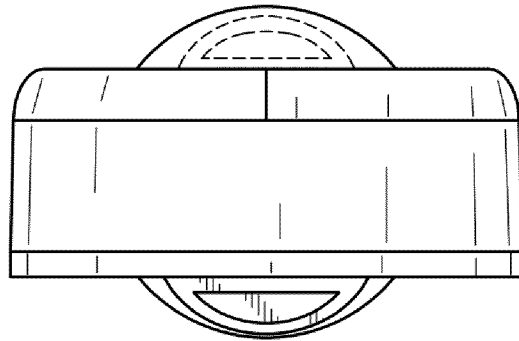

FIG. 6

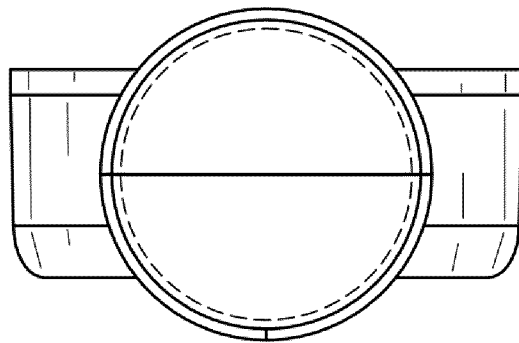

FIG. 7