



(51) International Patent Classification:

H02M 5/00 (2006.01) *H02M 7/00* (2006.01)
A61M 1/00 (2006.01)

(21) International Application Number:

PCT/NZ2016/050073

(22) International Filing Date:

9 May 2016 (09.05.2016)

(25) Filing Language:

English

(26) Publication Language:

English

(30) Priority Data:

707891 8 May 2015 (08.05.2015) NZ

(71) Applicant: **ARGUS HEATING LIMITED** [NZ/NZ]; 211
Maces Road, Bromley, Christchurch, 8062 (NZ).

(72) Inventor: **PHILPOTT, Murray John**; 75 Totara Street,
Fendalton, Christchurch, 8041 (NZ).

(74) Agent: **BALDWINS INTELLECTUAL PROPERTY**;
Level 15, HSBC House, 1 Queen Street, Auckland, Auckland,
1010 (NZ).

(81) Designated States (unless otherwise indicated, for every

kind of national protection available): AE, AG, AL, AM, AO, AT, AU, AZ, BA, BB, BG, BH, BN, BR, BW, BY, BZ, CA, CH, CL, CN, CO, CR, CU, CZ, DE, DK, DM, DO, DZ, EC, EE, EG, ES, FI, GB, GD, GE, GH, GM, GT, HN, HR, HU, ID, IL, IN, IR, IS, JP, KE, KG, KN, KP, KR, KZ, LA, LC, LK, LR, LS, LU, LY, MA, MD, ME, MG, MK, MN, MW, MX, MY, MZ, NA, NG, NI, NO, NZ, OM, PA, PE, PG, PH, PL, PT, QA, RO, RS, RU, RW, SA, SC, SD, SE, SG, SK, SL, SM, ST, SV, SY, TH, TJ, TM, TN, TR, TT, TZ, UA, UG, US, UZ, VC, VN, ZA, ZM, ZW.

(84) Designated States (unless otherwise indicated, for every

kind of regional protection available): ARIPO (BW, GH, GM, KE, LR, LS, MW, MZ, NA, RW, SD, SL, ST, SZ, TZ, UG, ZM, ZW), Eurasian (AM, AZ, BY, KG, KZ, RU, TJ, TM), European (AL, AT, BE, BG, CH, CY, CZ, DE, DK, EE, ES, FI, FR, GB, GR, HR, HU, IE, IS, IT, LT, LU, LV, MC, MK, MT, NL, NO, PL, PT, RO, RS, SE, SI, SK, SM, TR), OAPI (BF, BJ, CF, CG, CI, CM, GA, GN, GQ, GW, KM, ML, MR, NE, SN, TD, TG).

Published:

— with international search report (Art. 21(3))



WO 2016/182454 A1

(54) Title: IMPROVEMENTS IN, OR RELATING TO, HEATING

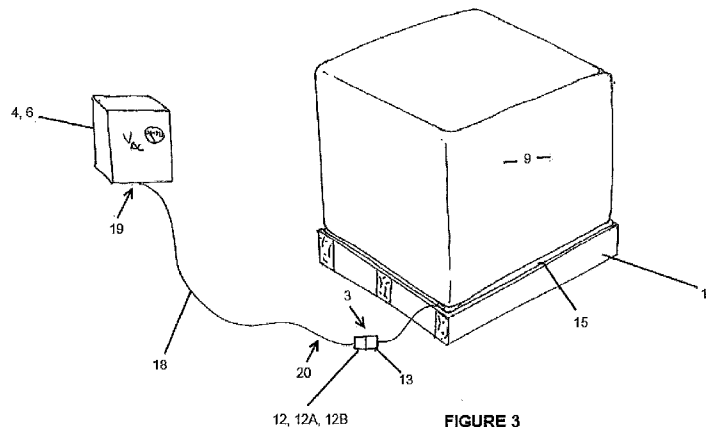

FIGURE 3

(57) Abstract: Disclosed is a multi-voltage electrical apparatus comprising or including, an electrical load that can connect via an electrical connection separately to both of either, a first electrical source at a first voltage, and a second electrical source at a second voltage. The electrical load is connected in series via the electrical connection to the first electrical source, or in parallel via the electrical connection to the second electrical source. The electrical load when connected in series or parallel having substantially the same power output.

IMPROVEMENTS IN, OR RELATING TO, HEATING**TECHNICAL FIELD OF THE INVENTION**

The present invention relates to electrical connections for slip heater pads.

5

In particular, though not solely, the present invention is directed to dual voltage connectors which are passive and allow for connection to one or another voltage to power a universal slip heater pad for example for heating of an Intermediate Bulk Container (IBC).

10

BACKGROUND OF THE INVENTION

A problem arises when product moves from one country to another that requires an electrical connection. This problem is further compounded when it moves from one country to another and those countries have differing electrical levels, for example 15 230VAC for Australia or New Zealand, and then 115VAC for the United States.

There have been various solutions up until now.

One solution to connecting the same item into both voltages has required an active power 20 supply to drop or raise the voltage to the operating voltage of the connected equipment. This has the problem of the added cost and potential fragility of the power supply. This problem is exacerbated when the attached equipment is considered a throwaway product, and therefore there is no re-use of the equipment or power supply. This leads to cost and waste.

25

The solution of having these power sources at each site is undesirable from a point of view of cost and maintenance, and the location may not have the ability or capacity to support a multitude of power supplies, sources and connections.

30 Another solution is to have the equipment requiring connection to have dual circuits, one rated for one voltage and another rate for another, and so on. This duplication can be wasteful in cost and materials because it may only be one voltage connection ultimately that is needed, for example at destination. Therefore the duplicated circuit for the other voltage is not used.

35

Another solution can be the use of an interchangeable circuit board to allow connection 240VAC and 110VAC to the connected equipment. However the cost of such circuit

board systems can be relatively high and reliability may become an issue. Also this system requires the time and effort of the user to switch the circuit board over and is reliant on the user having checked the correct circuit board is in place or changing the board over for the correct voltage. This is a draw back and may allow connection of the
5 incorrect voltage.

In this specification where reference has been made to patent specifications, other external documents, or other sources of information, this is generally for the purpose of providing a context for discussing the features of the invention. Unless specifically stated
10 otherwise, reference to such external documents is not to be construed as an admission that such documents, or such sources of information, in any jurisdiction, are prior art, or form part of the common general knowledge in the art.

It is therefore an object of the present invention to provide an improved multi-voltage
15 electrical connection, or to overcome the above shortcomings or address the above desiderata, or to at least provide the public with a useful choice.

BRIEF DESCRIPTION OF THE INVENTION

In a first aspect the present invention may be said to broadly consist in a **multi-voltage**
20 **electrical apparatus** comprising or including,

An electrical load that can connect via an electrical connection separately to both of either,

a first electrical source at a first voltage, and

a second electrical source at a second voltage,

25 Wherein said electrical load is connected in series via said electrical connection to said first electrical source, or in parallel via said electrical connection to said second electrical source,

Said electrical load when connected in series or parallel having substantially the same power output.

30

Preferably said electrical load is a resistive heater.

Preferably said power output of said electrical load is substantially thermal.

35 Preferably said load is a resistive heater for any one or more of,

- an intermediate bulk container,
- bulk containers,

- drums,
 - barrels
 - storage containers,
 - tanks, and
- 5 • hoppers.

Preferably said electrical connection has a termination for connection with said electrical load.

- 10 Preferably said electrical connection is supplied at least with said termination in a first configuration for series connection of said electrical load to said first electrical source.

Preferably said electrical connection is supplied with said termination in a second configuration for parallel connection of said electrical load to said second electrical source.

15

Preferably said electrical load has a connection point that can connect to said termination in both said first configuration and said second configuration.

- 20 Preferably said series or parallel connection of said electrical load is achieved through series or parallel connection of said electrical load to said first electrical source and said second electrical source respectively via connection of said termination and said connection point.

Preferably said termination consists of a socket.

25

Preferably said connection point is a plug.

Preferably said termination is at an end of a flexible electrical lead, distal from said power source.

30

Preferably said connection point is at a periphery of said electrical load.

- 35 Preferably said electrical connection has electrical contacts arranged therein to connect said load in parallel or series dependent on whether said first termination or said second termination is connected thereto.

Preferably said first voltage is higher than said second voltage.

Preferably said first voltage is 240 volts alternating current.

Preferably said second voltage is 110 volts alternating current.

5

Preferably said connection point is mounted on said electrical load, said container or part thereof, or remote from the electrical load at the end of an electrical lead.

10 In another aspect the present invention may be said to broadly consist in a **heating element** adapted to heat an intermediate bulk container, comprising or including,

An electrical load that can connect via an electrical connection separately to both of either, a first electrical source at a first voltage, and a second electrical source at a second voltage,

15 Wherein said first electrical source via said electrical connection is applied to said load in series, and said second electrical source via said electrical connection is applied to said to load in parallel,

Said electrical load when connected in series or parallel said having substantially the same power output.

20 In another aspect the present invention may be said to broadly consist in a **multi-voltage electrical apparatus** as described herein with reference to any one or more of the accompanying drawings.

25 In another aspect the present invention may be said to broadly consist in a **heating element** as described herein with reference to any one or more of the accompanying drawings.

As used herein “(s)” following a noun means the plural and/or singular forms of the noun.

30 The term “comprising” as used in this specification means “consisting at least in part of”. When interpreting statements in this specification which include that term, the features, prefaced by that term in each statement, all need to be present, but other features can also be present. Related terms such as “comprise” and “comprised” are to be interpreted in the same manner.

35

It is intended that reference to a range of numbers disclosed herein (for example, 1 to 10) also incorporates reference to all rational numbers within that range (for example, 1, 1.1,

2, 3, 3.9, 4, 5, 6, 6.5, 7, 8, 9 and 10) and also any range of rational numbers within that range (for example, 2 to 8, 1.5 to 5.5 and 3.1 to 4.7).

The entire disclosures of all applications, patents and publications, cited above and below,
5 if any, are hereby incorporated by reference.

This invention may also be said broadly to consist in the parts, elements and features referred to or indicated in the specification of the application, individually or collectively, and any or all combinations of any two or more of said parts, elements and features, and
10 where specific integers are mentioned herein which have known equivalents in the art to which this invention relates, such known equivalents are deemed to be incorporated herein as if individually set forth.

Other aspects of the invention may become apparent from the following description which
15 is given by way of example only and with reference to the accompanying drawings.

BRIEF DESCRIPTION OF THE DRAWINGS

Preferred forms of the present invention will now be described with reference to the accompanying drawings in which;

20

Figure 1 Shows at (A) and (B) the circuit diagrams of the electrical load connected to an alternating current electrical (first) source in series, and (C) the same electrical load connected to an alternative current electrical (second) source in parallel, and (D) the circuit diagram for the parallel connection,

25

Figure 2 Shows in plan view the electrical load as a slip pad heater, for example as used to heat an intermediate bulk container,

30

Figure 3 Shows the slip pad heater located underneath an intermediate bulk container and above a pallet,

Figure 4 Shows a socket as an example of a termination for the electrical sources, in (A) end elevation, (B) side elevation, and (C) top elevation,

35

Figure 5 Shows a plug for said electrical load complimentary to the socket of Figure 4 in (A) end elevation, (B) side elevation, and (C) top elevation,

Figure 6 Shows a diagram for connection between the termination from the electrical source and the connection on the electrical load for series connection, and

Figure 7 Shows a diagram for connection between the termination from the electrical source and the connection on the electrical load for parallel connection.

DETAILED DESCRIPTION OF THE INVENTION

Preferred embodiments will now be described with reference to Figures 1 through 7.

10 A multi-voltage electrical apparatus 1 is shown in Figure 1 in wired in series (A and B) and parallel (C and D). The electrical load in one preferred form is a planar winding of resistance wire or heater cable with a given resistance per length (Ohms/m). This planar array, as resistance wire, is shown in Figure 2 where the planar array is a slip pad heater 15. A slip pad heater 15 as earlier described is used to heat the content of an
15 intermediate bulk container 9, as shown in Figure 3. As shown in Figure 3 the slip pad heater 15 is located or incorporated in the components between the bulk container 9 that contains the product to be heated and the pallet 17 the container 9 rests on. As the container content will often weigh in excess of a 1000kg and the container 9 is fragile the slip pad heater 15 is located underneath the container 9 and above the pallet 17 (or
20 equivalent) in most cases prior to filling the container 9 with its content. Location under the bulk of the product to be heated also enables sufficient heat transfer to the contents of the container due to the increased contact pressure between the container 9 and the heater 15 due to the weight of the product in the container 9.

25 The slip pad heater 15 shown in Figure 2 is of known construction and the resistance wire is often laminated between two sheets of film, for example aluminium foil or similar as heat conducting material directly against the container, and heat reflecting material on the outside of the slip pad heater to reflect heat back towards the container 9. In other embodiments the underside may be of paper based material as this is cost effective. The
30 heater 15 is made from a length of resistance wire or heater cable, for example as laid out as shown. The ends of the length terminate in electrical contacts 16A and 16C, and also a mid-point (resistance wise) connection 16B. An earth connection 16D is also shown to allow earthing of the heater 15.

35 The parallel and series electrical connection of the electrical load is shown schematically in Figure 1A,B for series and Figure 1 C, D for parallel. In the preferred form there are three electrical contacts 16A, 16B and 16C, and optionally a fourth electrical contact 16D

as an earth on the electrical load, and electrical source live 21, electrical source neutral 22, and electrical source earth 23.

5 In the series form, shown in Figures 1A,B and Figure 6, the first electrical source 4 is connected in series across electrical load contacts 16A and 16C as shown to form the series circuit with known electrical resistance R_s . In the preferred embodiment electrical source live 21 is connected to electrical contact 16A, electrical load neutral 22 connected to electrical load contact 16C (or vice versa) and electrical source earth 23 connected to electrical load earth 16D.

10

In the preferred form the first electrical source 4 is 240 Volts alternating (VAC) current, also referred to as 230 VAC, and sometimes as 220VAC. Other electrical connections may be present for other purposes but are not shown here and are not part of the present invention.

15

In the parallel form, shown in Figures 1C,D and Figure 7, the second electrical source 6 is connected in parallel across electrical load contacts 16A/16C and 16B as shown to form the parallel circuit with known electrical resistance R_p . In the preferred embodiment electrical source live 21 is connected to electrical contact 16A and 16C, electrical load neutral 22 connected to electrical load contact 16B (or vice versa) and electrical source earth 23 connected to electrical load earth 16D.

20

In the preferred form the second electrical source 6 is 115 Volts alternating (VAC) current, also referred to as 110 VAC, and sometimes as 120VAC. Other electrical connections may be present for other purposes but are not shown here and are not part of the present invention.

25

In use the slip pad heater 15 is located external to the container, and in the preferred embodiment, it is under the intermediate bulk container 9, as shown in Figure 3. However, in other forms the heater 15 can be located on top, or about the side, or sides of the contents, or a combination thereof, that requires heating by the resistive heater 8.

30

When the content of the container 9 needs to be heated the heater 15 is connected to the available electrical source 4 or 6 – the voltage of which will depend on typically the geographic location the container 9 is in. For example if the container 9 is in the United States the electrical source would typically be 110VAC (or 115VAC), and if in New

35

Zealand the voltage would be 230 VAC (or 240VAC). The present invention contemplates the electrical source is, in the preferred embodiment, single phase.

The connection to the electrical source 4 or 6 in the preferred form is by an electrical cord 18. At the electrical source 4,6 end 19 of the cord 18 there is the typical connection required for that particular source, e.g. three pin plug for New Zealand. At the heater connecting end 20 there is the connection 3 with the resistive heater 8 of the slip pad heater 15. In the preferred embodiment this electrical connection 3 is achieved via a termination that is a socket 12 from the electrical source and a plug 13 as a connection point from the resistive heater 8. However, other forms may be acceptable also. The electrical connection 3 may extend from the slip pad heater 15 with a cord as shown, or may be located on the slip pad heater 15 itself, or maybe mounted on the container 9.

The socket 12 (in the preferred embodiment) of the electrical connection 3 has two configurations, a first 12A (for first termination) and second 12B (for second termination), as shown in Figures 6 and 7. The first 12A connects via the plug 13 (as the connection from the electrical load) the electrical load 2 (for example as shown the resistive heater 8) in series to the first electrical source 4, and the second 12B connects via the plug 13 the electrical load (for example as shown the resistive heater 8) in parallel to the second electrical source 6. All the contacts 16A, 16B, and 16C are located in the plug 13, and it is the specific sockets 12A and 12B and the arrangement of their connections inside that connects them in series or parallel with the electrical load of the slip pad as necessary.

As can be seen in Figure 4A the plug 12 has so that it can only fit into the plug 13 in one way, thus ensuring correct alignment of the contacts each time. In the preferred form shown there are complimentary keys 24 and keyways 25 in the socket 12 and plug 13 to ensure they connect in the right orientation each time. Optionally there may also be locking portions to hold the two together in addition to any friction between the two, for example, but not limited to clips, or a bayonet style one or two part twist connection (not shown).

Therefore the electrical cord 18 and specific socket 12 connected is specific to a voltage. For example the first socket 12A and its cord 18 for series connection is supplied for example to 230Vac countries and the second socket 12B and its cord 18 for parallel connection is supplied to 115Vac countries.

While a plug 13 and socket 12 connection is described here, it could be a socket and plug connection, or any other form of equivalent electrical connection.

When the first electrical source 4 is connected as described above, and is preferably at
5 the higher voltage, the electrical connection 3 connects the resistive heater 8 in series as
shown in Figure 1A, and B. This is achieved by the arrangement of electrical contacts 21,
22 and 23 within the socket 12A, and their connection to those in the plug 13, as
described above. One possible configuration is shown in Figure 6 where the first socket
12 A is shown and has contacts to the first electrical source of electrical source live 21,
10 electrical source neutral 22 and electrical source earth 23 – the fourth contact shown has
no electrical function assigned. Likewise in the plug 13, there is the contact 16A to one
arm of the electrical load 2, which connects in this configuration to electrical source live 21
in the socket 12A. Likewise there is electrical contact 16C (to the other arm) to electrical
source neutral 22, and electrical contact 16D (earth) to electrical source earth 23.

15

In the alternative when the second electrical source 6 is connected as described above,
and is preferably the lower voltage, the electrical connection 3 connects the resistive
heater 8 in parallel as shown in Figure 1C and D. This is achieved by the arrangement of
electrical contacts 21, 22, and 23 within the socket 12B, and their connection to those in
20 the plug 13, as described above. One possible configuration is shown in Figure 7 where
the second socket 12B is shown and has two live contacts to the first electrical source of
electrical source live 21, electrical source neutral 22 and electrical source earth 23.
Likewise in the plug 13, there is the contact 16A and 16C to one arm of the electrical load
2, which connects in this configuration to electrical source live 21 in the socket 12A.
25 Likewise there is electrical contact 16B (to the other arm) to electrical source neutral 22,
and electrical contact 16D (earth) to electrical source earth 23.

The advantage of the present invention is that irrespective of the location of the container
9 and the voltage in that country, the slip pad heater with a standardised plug can be
30 connected by use of the correct plug to the electrical source present. This has
advantages in that the slip pad heater, and its electrical connection can be standardised,
yet still work with dual voltages.

The foregoing description of the invention includes preferred forms thereof. Modifications
35 may be made thereto without departing from the scope of the invention.

WHAT WE CLAIM IS:

1. A **multi-voltage electrical apparatus** comprising or including,
An electrical load that can connect via an electrical connection separately to both
5 of either,
a first electrical source at a first voltage, and
a second electrical source at a second voltage,
Wherein said electrical load is connected in series via said electrical connection to
said first electrical source, or in parallel via said electrical connection to said second
10 electrical source,
Said electrical load when connected in series or parallel having substantially the
same power output.
2. An apparatus as claimed in claim 1 wherein said electrical load is a resistive heater.
15
3. An apparatus as claimed in either claim 1 or claim 2 wherein said power output of said
electrical load is substantially thermal.
4. An apparatus as claimed in any one of claims 1 to 3 wherein said electrical load is a
20 resistive heater for any one or more of,
 - an intermediate bulk container,
 - bulk containers,
 - drums,
 - barrels
 - 25 • storage containers,
 - tanks, and
 - hoppers.
5. An apparatus as claimed in any one of claims 1 to 4 wherein said electrical connection
30 has a termination for connection with said electrical load.
6. An apparatus as claimed in any one of claims 1 to 5 wherein said electrical connection
is supplied at least with said termination in a first configuration for series connection of
said electrical load to said first electrical source.
35
7. An apparatus as claimed in any one of claims 1 to 6 wherein said electrical connection

is supplied with said termination in a second configuration for parallel connection of said electrical load to said second electrical source.

8. An apparatus as claimed in any one of claims 1 to 7 wherein said electrical load has a connection point that can connect to said termination in both said first configuration and said second configuration.
9. An apparatus as claimed in any one of claims 1 to 8 wherein said series or parallel connection of said electrical load is achieved through series or parallel connection of said electrical load to said first electrical source and said second electrical source respectively via connection of said termination and said connection point.
10. An apparatus as claimed in any one of claims 1 to 9 wherein said termination consists of a socket.
11. An apparatus as claimed in any one of claims 1 to 10 wherein said connection point is a plug.
12. An apparatus as claimed in any one of claims 1 to 11 wherein said termination is at an end of a flexible electrical lead, distal from said power source.
13. An apparatus as claimed in any one of claims 1 to 12 wherein said connection point is at a periphery of said electrical load.
14. An apparatus as claimed in any one of claims 1 to 13 wherein said electrical connection has electrical contacts arranged therein to connect said load in parallel or series dependent on whether said first termination or said second termination is connected thereto.
15. An apparatus as claimed in any one of claims 1 to 14 wherein said first voltage is higher than said second voltage.
16. An apparatus as claimed in any one of claims 1 to 15 wherein said first voltage is 240 volts alternating current.
17. An apparatus as claimed in any one of claims 1 to 16 wherein said second voltage is 110 volts alternative current.

18. An apparatus as claimed in any one of claims 8 to 17 when dependent on claim 8 wherein said connection point is mounted on said electrical load, said container or part thereof, or remote from the electrical load at the end of an electrical lead.

5

19. **A heating element** adapted to heat an intermediate bulk container, comprising or including,

An electrical load that can connect via an electrical connection separately to both of either, a first electrical source at a first voltage, and a second electrical source at a second voltage,

10

Wherein said first electrical source via said electrical connection is applied to said load in series, and said second electrical source via said electrical connection is applied to said load in parallel,

15

Said electrical load when connected in series or parallel said having substantially the same power output.

20. A heating element as claimed in claim 19 wherein the heating element is a length or resistive wire or heating cable with electrical connections at either end to enable series connection, and in addition a mid-point electrical connection to enable parallel connection.

20

21. **A multi-voltage electrical apparatus** as described herein with reference to any one or more of the accompanying drawings.

25

22. **A heating element** as described herein with reference to any one or more of the accompanying drawings.

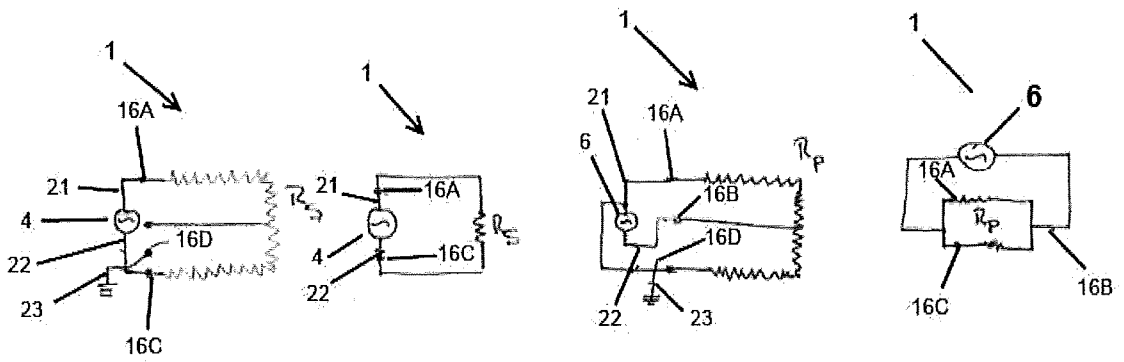

FIGURE 1

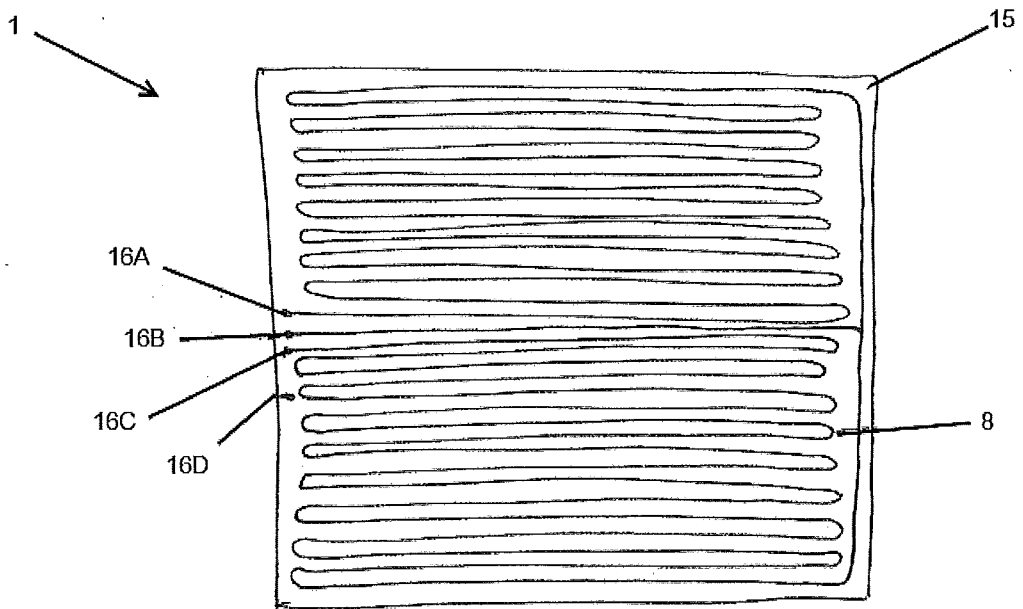

FIGURE 2

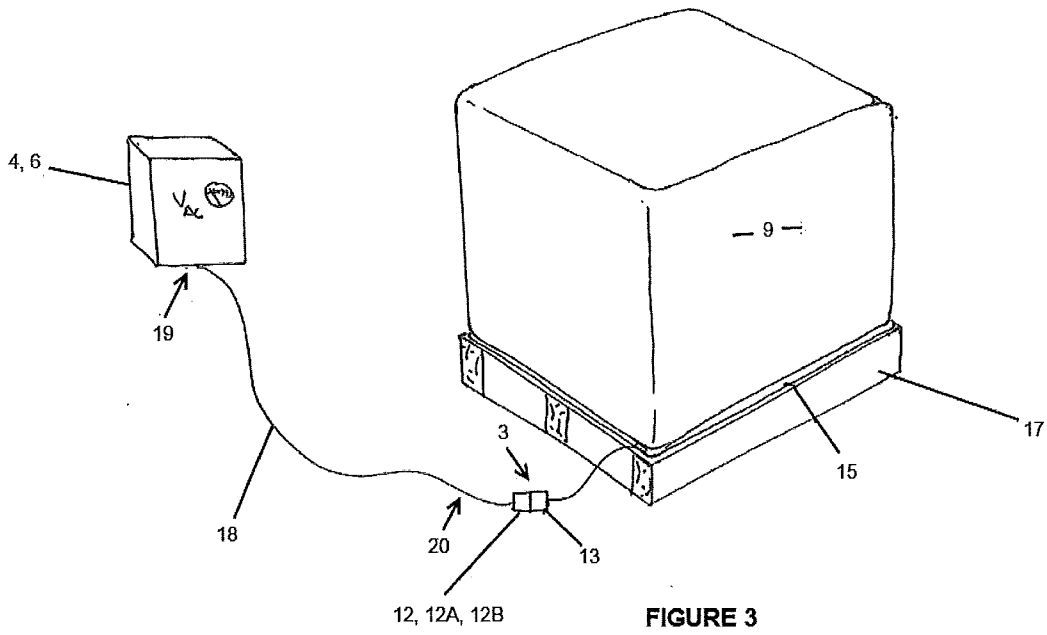

FIGURE 3

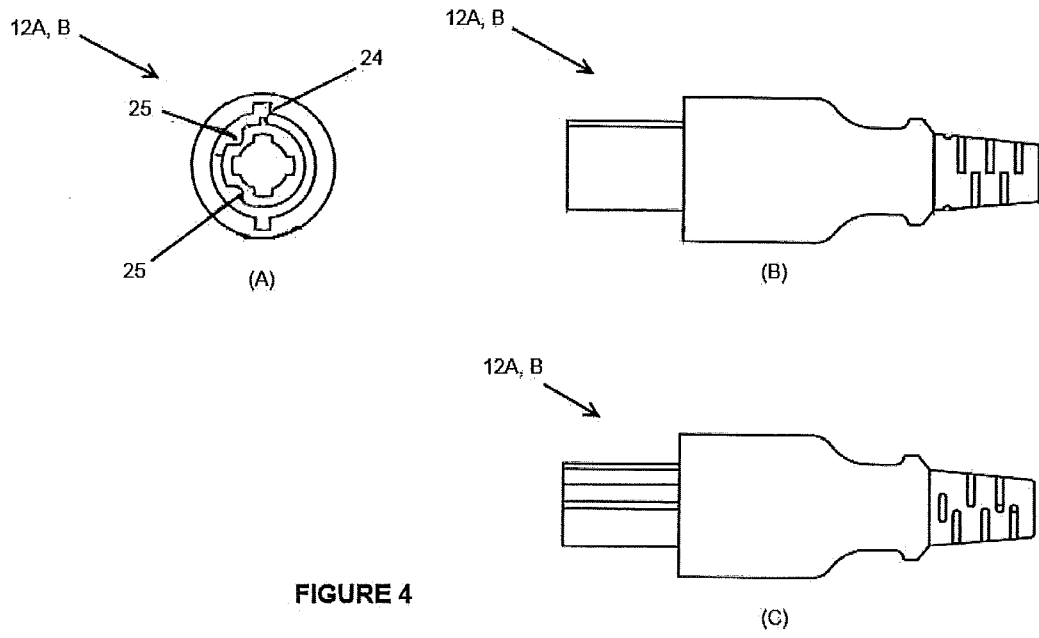

FIGURE 4

5/7

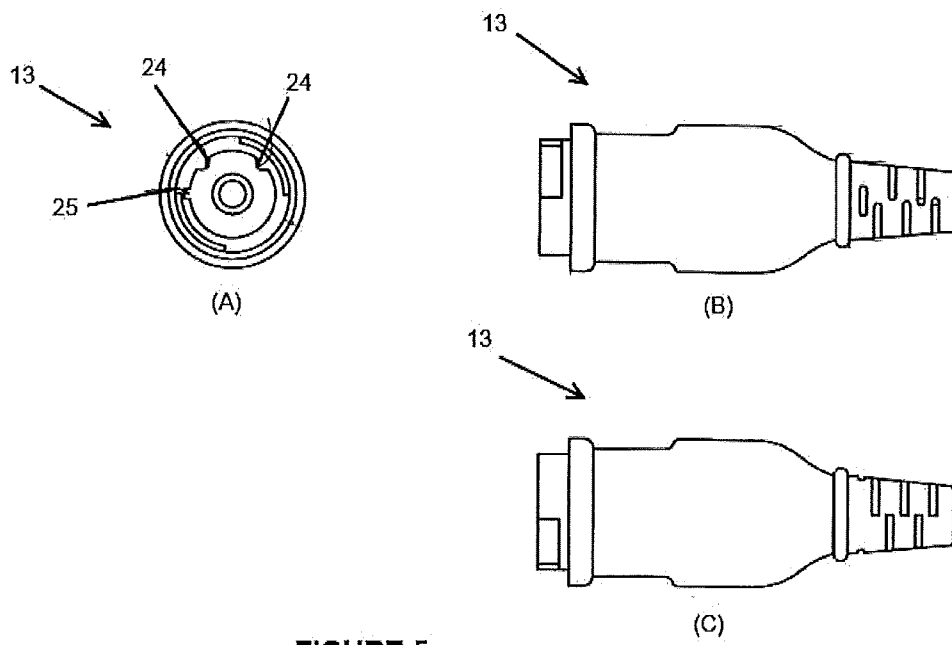

FIGURE 5

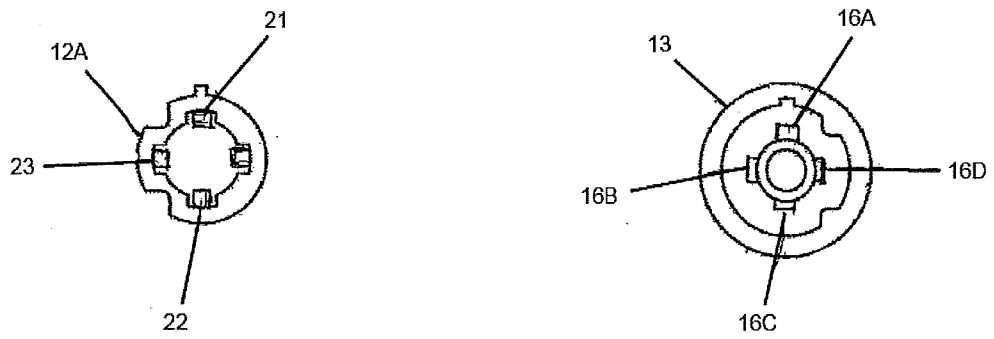

FIGURE 6

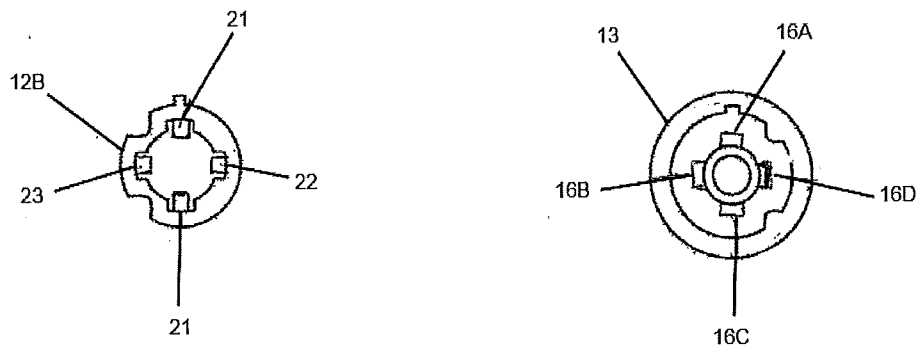

FIGURE 7

INTERNATIONAL SEARCH REPORT

International application No.
PCT/NZ2016/050073

A. CLASSIFICATION OF SUBJECT MATTER H02M 5/00 (2006.01) A61M 1/00 (2006.01) H02M 7/00 (2006.01)		
According to International Patent Classification (IPC) or to both national classification and IPC		
B. FIELDS SEARCHED		
Minimum documentation searched (classification system followed by classification symbols)		
Documentation searched other than minimum documentation to the extent that such documents are included in the fields searched		
Electronic data base consulted during the international search (name of data base and, where practicable, search terms used) Databases: WPIAP, EPODOC, INSPEC, Google Patents, Google Scholar and Espacenet: CPCs- H02M5/02/LOW OR H01C1/14 OR H05B1/00 OR H05B3/00 OR H01R29/00 OR G05F1/00 Keywords: multi, voltage, power, input, electrical, series, parallel, load, resistance, resistor, output, wattage, thermal, same, steady, heater, slip pad, IBC, drum, connect, configure, socket, plug, distal, length, cable, wire, first, second, primary and similar terms. Espacenet/AusPat searched with keywords (applicant/inventors): Argus Heating as the applicant, Philpott Murray John as the inventor. Applicant/Inventors name searched in internal databases provided by IP Australia.		
C. DOCUMENTS CONSIDERED TO BE RELEVANT		
Category*	Citation of document, with indication, where appropriate, of the relevant passages	Relevant to claim No.
	Documents are listed in the continuation of Box C	
<input checked="" type="checkbox"/> Further documents are listed in the continuation of Box C <input checked="" type="checkbox"/> See patent family annex		
* "A"	Special categories of cited documents: document defining the general state of the art which is not considered to be of particular relevance	"T" later document published after the international filing date or priority date and not in conflict with the application but cited to understand the principle or theory underlying the invention
"E"	earlier application or patent but published on or after the international filing date	"X" document of particular relevance; the claimed invention cannot be considered novel or cannot be considered to involve an inventive step when the document is taken alone
"L"	document which may throw doubts on priority claim(s) or which is cited to establish the publication date of another citation or other special reason (as specified)	"Y" document of particular relevance; the claimed invention cannot be considered to involve an inventive step when the document is combined with one or more other such documents, such combination being obvious to a person skilled in the art
"O"	document referring to an oral disclosure, use, exhibition or other means	"&" document member of the same patent family
"P"	document published prior to the international filing date but later than the priority date claimed	
Date of the actual completion of the international search 26 July 2016	Date of mailing of the international search report 26 July 2016	
Name and mailing address of the ISA/AU AUSTRALIAN PATENT OFFICE PO BOX 200, WODEN ACT 2606, AUSTRALIA Email address: pct@ipaustalia.gov.au		Authorised officer Prakash Prasai AUSTRALIAN PATENT OFFICE (ISO 9001 Quality Certified Service) Telephone No. 0262832939

Box No. II Observations where certain claims were found unsearchable (Continuation of item 2 of first sheet)

This international search report has not been established in respect of certain claims under Article 17(2)(a) for the following reasons:

1. Claims Nos.:
because they relate to subject matter not required to be searched by this Authority, namely:
the subject matter listed in Rule 39 on which, under Article 17(2)(a)(i), an international search is not required to be carried out, including
2. Claims Nos.: **21-22**
because they relate to parts of the international application that do not comply with the prescribed requirements to such an extent that no meaningful international search can be carried out, specifically:
See Supplemental Box
3. Claims Nos.:
because they are dependent claims and are not drafted in accordance with the second and third sentences of Rule 6.4(a)

Box No. III Observations where unity of invention is lacking (Continuation of item 3 of first sheet)

This International Searching Authority found multiple inventions in this international application, as follows:

1. As all required additional search fees were timely paid by the applicant, this international search report covers all searchable claims.
2. As all searchable claims could be searched without effort justifying additional fees, this Authority did not invite payment of additional fees.
3. As only some of the required additional search fees were timely paid by the applicant, this international search report covers only those claims for which fees were paid, specifically claims Nos.:
4. No required additional search fees were timely paid by the applicant. Consequently, this international search report is restricted to the invention first mentioned in the claims; it is covered by claims Nos.:

Remark on Protest

- The additional search fees were accompanied by the applicant's protest and, where applicable, the payment of a protest fee.
- The additional search fees were accompanied by the applicant's protest but the applicable protest fee was not paid within the time limit specified in the invitation.
- No protest accompanied the payment of additional search fees.

INTERNATIONAL SEARCH REPORT		International application No.
C (Continuation). DOCUMENTS CONSIDERED TO BE RELEVANT		PCT/NZ2016/050073
Category*	Citation of document, with indication, where appropriate, of the relevant passages	Relevant to claim No.
X	US 2012/0179133 A1 (BEDINGFIELD et al.) 12 July 2012 See the whole document particularly the abstract, figures 10-11, paragraphs [0010], [0016], [0085]-[0108], claim 1.	1-20
X	US 2008/0058712 A1 (PLAHEY) 06 March 2008 See the whole document particularly the abstract, figures 3-6, paragraphs [0002], [0008]-[0014], [0031]-[0034], [0036], [0042], claim 1.	1-20
A	US 4410839 A (DOBKIN) 18 October 1983 See the whole document.	1-20
A	US 5687068 A (JAMIESON et al.) 11 November 1997 See the whole document.	1-20

Supplemental Box**Continuation of Box II**

The **claims 21-22** do not comply with Rule 6.2(a) because it/they rely on references to the description and/or drawings.

INTERNATIONAL SEARCH REPORT

Information on patent family members

International application No.

PCT/NZ2016/050073

This Annex lists known patent family members relating to the patent documents cited in the above-mentioned international search report. The Australian Patent Office is in no way liable for these particulars which are merely given for the purpose of information.

Patent Document/s Cited in Search Report		Patent Family Member/s	
Publication Number	Publication Date	Publication Number	Publication Date
US 2012/0179133 A1	12 July 2012	US 2012179133 A1	12 Jul 2012
		US 8644692 B2	04 Feb 2014
		US 2009213521 A1	27 Aug 2009
		US 8027572 B2	27 Sep 2011
		US 2011288480 A1	24 Nov 2011
		US 8160433 B2	17 Apr 2012
		WO 2009105413 A2	27 Aug 2009
US 2008/0058712 A1	06 March 2008	US 2008058712 A1	06 Mar 2008
		EP 1894586 A2	05 Mar 2008
		EP 1894586 B1	08 Jun 2011
		JP 2008055177 A	13 Mar 2008
		JP 5486153 B2	07 May 2014
		JP 2015164582 A	17 Sep 2015
		JP 5943495 B2	05 Jul 2016
		JP 2013248519 A	12 Dec 2013
US 4410839 A	18 October 1983	US 4410839 A	18 Oct 1983
		CA 1202077 A	18 Mar 1986
US 5687068 A	11 November 1997	US 5687068 A	11 Nov 1997
		CA 2179356 A1	23 Jun 1997

End of Annex

Due to data integration issues this family listing may not include 10 digit Australian applications filed since May 2001.

Form PCT/ISA/210 (Family Annex)(July 2009)