

Oct. 31, 1950

H. D. TICHENOR

2,528,256

EGG CASE

Filed June 7, 1948

2 Sheets-Sheet 1

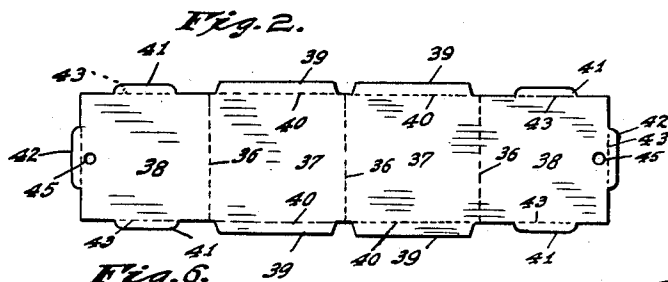
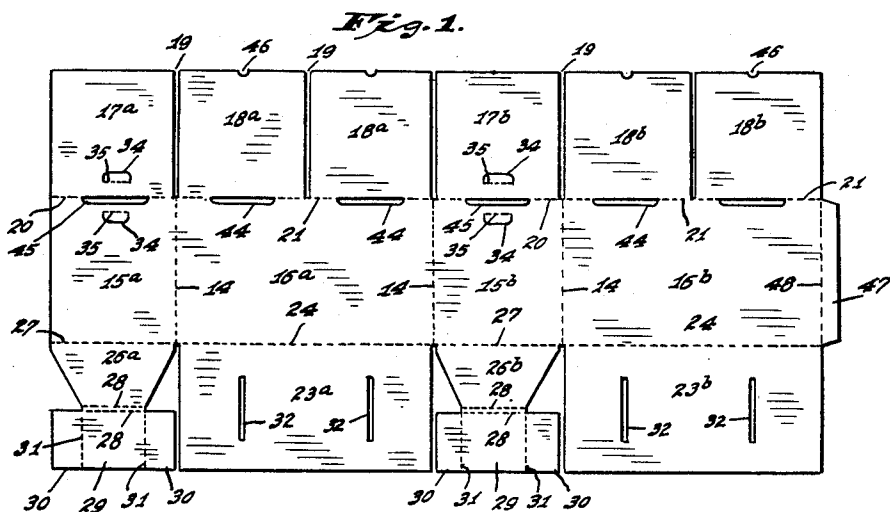

Fig. 5.

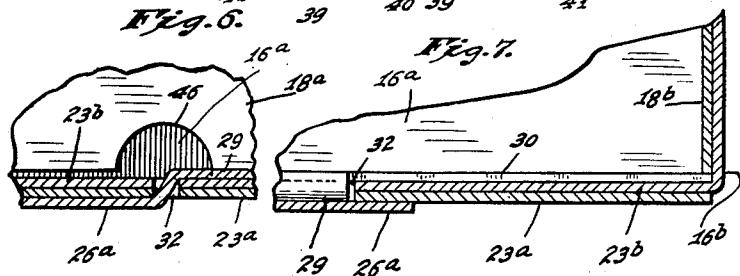
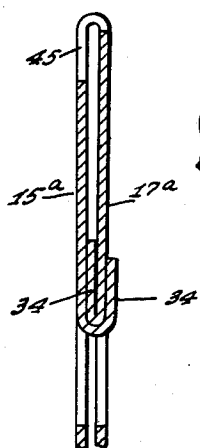

Fig. 7.

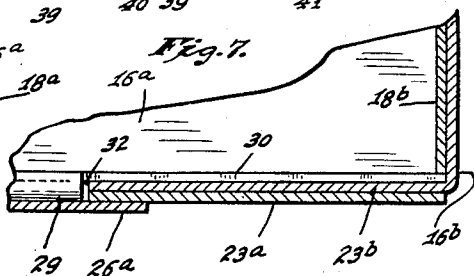

Fig. 8.

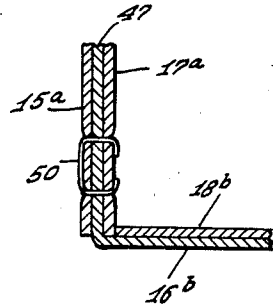
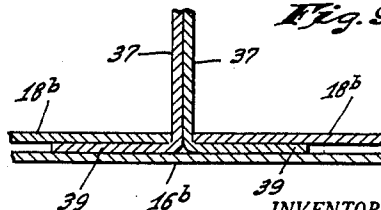

Fig. 9.



INVENTOR.
KAROLD. D. TICHENOR,

BY

Arthur J. Rubin
ATTORNEYS.

Oct. 31, 1950

H. D. TICHENOR

2,528,256

EGG CASE

Filed June 7, 1948

2 Sheets-Sheet 2

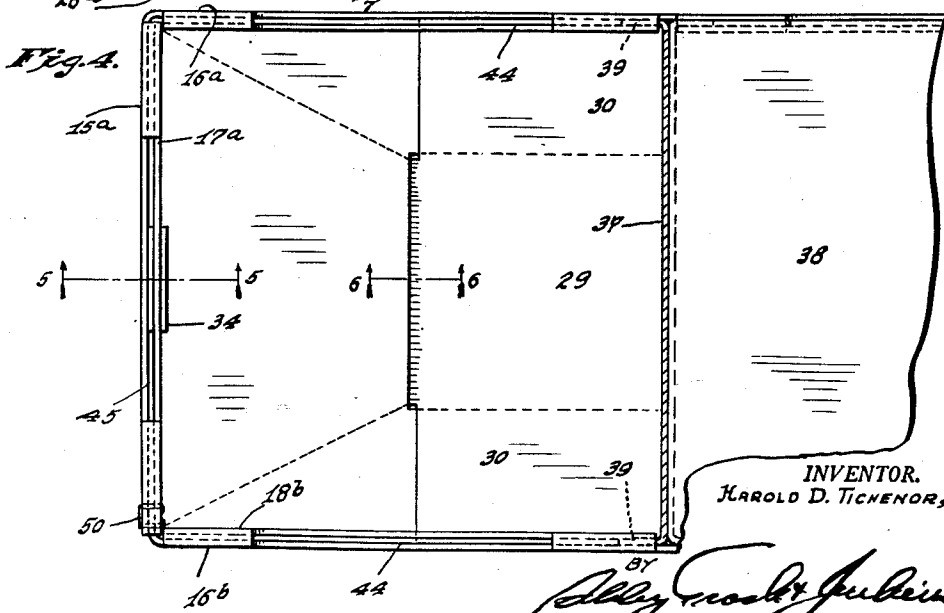
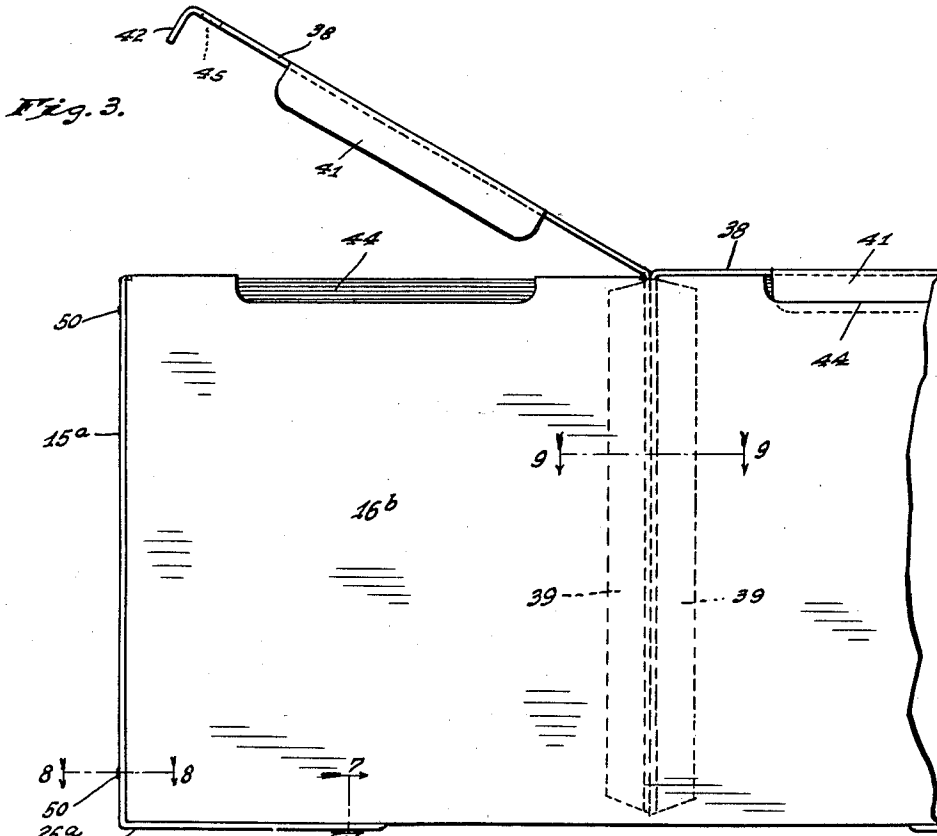

INVENTOR.
HAROLD D. TICHENOR,

BY *Ally Crook & Julia*
ATTORNEYS.

UNITED STATES PATENT OFFICE

2,528,256

EGG CASE

Harold D. Tichenor, Pimento, Ind., assignor to
Wabash Fibre Box Co., Terre Haute, Ind., a
corporation of Indiana

Application June 7, 1948, Serial No. 31,529

1 Claim. (Cl. 229—39)

1

This invention relates to an egg case suitable for use in the packing and transportation of eggs and capable of being simply and economically manufactured from flexible material such as corrugated board, or the like. A further object of the invention is to produce an egg case which can be shipped and stored in knocked-down condition but which can readily be erected when it is to be used.

In carrying out my invention, I form the case of two blanks of foldable material, such as corrugated board. One of these blanks comprises a body portion scored to form outer end and side wall panels, provided on one side with inwardly foldable flaps adapted to form inner side and end wall panels, and provided along its opposite side with spaced bottom flaps adapted to be folded inwardly into overlapping relationship to provide a double-thickness bottom. In addition, the body portion of the blank is provided with flaps terminating in tongues which can be inserted through slots in the superposed bottom panels and locked in place by the in-folded inner side wall panels. The other blank comprises a body portion scored to provide two central panels and two end panels, the former being foldable into superposed relation to form a central partition dividing the interior of the egg case into two compartments and the latter being adapted to serve as hinged covers for the respective compartments.

The accompanying drawings illustrate my invention:

Figs. 1 and 2 are views of the two blanks used in the construction of the case; Fig. 3 is a fragmental side elevation of the completed case; Fig. 4 is a fragmental plan of the erected case with one cover removed; Figs. 5 and 6 are vertical sections on the lines 5—5 and 6—6 respectively of Fig. 4; Fig. 7 is a vertical section on the line 7—7 of Fig. 3; and Figs. 8 and 9 are horizontal sections on the lines 8—8 and 9—9 respectively of Fig. 3.

The main blank, from which the body of the case is formed, is illustrated in Fig. 1. It comprises a central, rectangular body portion scored transversely to provide outer end-wall panels 15a and 15b and outer side-wall panels 16a and 16b. Along one side of the blank, I provide inner end-wall panels 17a and 17b and two pairs of inner side-wall panels 18a and 18b. The inner wall panels are all separated from each other by slots 19. The inner end-wall panels are separated from the corresponding outer end-wall panels by score lines 20, while the pairs of inner side-wall

2

panels are separated from the corresponding outer side-wall panels by score lines 21.

Opposite the inner wall panels, the blank is provided with bottom panels 23a and 23b, each separated from its associated side-wall panel by a score line 24. On the same side of the blank with the bottom panels 23 and in line with the respective end-wall panels, I provide flaps 26a and 26b separated from the adjacent outer end-wall panels by score lines 27.

Outwardly from the score lines 27, the sides of each of the flaps 26 converge to one of a pair of closely spaced score lines 28 located intermediate the extent of the flap 26. That portion of each flap 26 lying outwardly beyond the score line 28 constitutes a locking tongue 29 provided at its sides with ears 30 separated from the tongue 29 by parallel score lines 31.

The bottom flaps 23 are provided with parallel slots 32 which are positioned to be disposed in aligned relation when the box is erected to receive the tongues 29 on the flaps 26, as will be more fully explained hereinafter. If it is desired that hand holes be embodied in the egg case to facilitate its handling, provision for such hand holes may be incorporated in the outer and inner end wall panels 15 and 17. As shown in Fig. 1, each end wall panel is provided for this purpose with a generally rectangular tongue 34 separated from the end wall panel on three sides but joined thereto at the fourth side along a score line 35. The tongues 34 are so disposed that when the pair of panels 15 and 17 which bear them are folded into superposed relation about the score line 20, the tongues will be brought into aligned position, in a manner more fully described hereinafter.

The second blank used in my improved egg case is shown in Fig. 2. Such blank is rectangular in form and is provided with transversely extending score lines 36 defining two center panels 37 and two end panels 38. Each of the center panels 37 is provided along its side edges with a tab 39 separated from the associated panel 37 by a score line 40. In the assembled case, the blank of Fig. 2 is folded about the center score line 36 to bring the panels 37 into superposed relationship, enabling them to serve as a double-thickness partition dividing the assembled egg case into two compartments. The end panels 38 constitute hinged covers for the respective compartments and are desirably provided along their side and end edges with flanges cooperating with the side and end walls of the case. In the particular blank shown in Fig. 2, each of such flanges

3

is adapted to enter between the two thicknesses of the end and side walls of the case when the cover is closed, and each flange is therefore in the form of a tab, 41 or 42, having a length less than that of the adjacent edge of the panel 38 and being separated from such panel by a score line 43.

For the purpose of adapting the egg case to receive the tabs 41 and 42 on the covers, the outer side-wall panels of the main blank are provided at their score lines 21 with slots 44 having a length slightly greater than that of the tabs 41 at the sides of the cover-panels 38; and the outer end-wall panels 15 are provided with similar slots 45 having a length equal to or slightly greater than that of the tabs 42 on the ends of the cover-panels 38. The width of each slot 44 and 45 is desirably less than the width of the tab 41 or 42 which it is to receive.

At one end of the blank shown in Fig. 1, the body thereof is provided with a flap 47 adapted to overlap and be secured to the opposite end of the central portion of the body of the blank as a preliminary operation in the assembly of the egg crate. As shown, the flap 47 is provided at the outer end of the side-wall panel 15b and is adapted to overlap the edge of the end-wall panel 15a, as will be brought out more fully hereinafter.

After the blanks shown in Figs. 1 and 2 have been cut as above described, the main blank is folded about the score lines 14 and 48 to bring the flap 47 into overlapping relationship with the panel 15a, with the score line 48 substantially coinciding with the outer edge of the panel 15a. The flap 17a is then folded inwardly about the score line 20 to overlap the flap 47, and the triple-thickness assembly thus created is stapled together as indicated at 50 in Fig. 8. To complete erection of the egg case, the inner end-wall panel 17b is folded inwardly about the score line 20 into superposed relationship with the outer end-wall panel 15b, and the bottom panels 23a and 23b are folded inwardly into superposed relation about the respective score lines 24, thus bringing the slots 32 on each of such bottom panels into alignment with the slots 32 of the other bottom panel. To lock the box in erected condition, the ears 30 on each of the flaps 26 are folded about the score lines 31 into superposed relation with the tongue 29 and the double-thickness assembly is inserted through the adjacent pair of aligned slots 32, following which the ears 30 are swung outwardly into coplanar relationship with the tongue 29 to lie with such tongue against the upper face of the innermost bottom panel 23. (Figs. 6 and 7.)

Before the inner side-wall panels 18 are folded inwardly, the combined partition-cover member constituted by the blank of Fig. 2 is doubled on itself at the center score line 36, the flaps 39 are folded oppositely into co-planar relationship about the score lines 40, and the doubled blank is lowered into the case with the folded edge downwardly and with the flaps 39 extending along the inner faces of the outer side-wall panels 16 as indicated in Fig. 3. The inner side-wall panels 18 are then folded inwardly about the score lines 21 to cover the flaps 39, as shown in Fig. 9.

The inner end-wall and side-wall panels 17 and 18 have a length such that when folded inwardly their free ends will frictionally engage the bottom of the case to retain them in in-folded position. The tongues 30 on the flaps 26 are prefera-

4

bly so proportioned as to extend outwardly into engagement with the inner faces of the outer side-wall panels (Fig. 7) with the result that when the inner side-wall panels 18 are folded inwardly into position the edges of the tongues 30 will be clamped between the edges of the inner side-wall panels and the bottom of the case, as will be clear from Fig. 7.

Prior to the inward folding of each inner end-wall panel 17, the hand-hole tongue 34 on such panel is desirably folded outwardly about the score line 35 to lie against the outer face of the side-wall panel and to be clamped between it and the outer side-wall panel when erection of the case is complete. As a final operation in perfecting the hand hole, the tongue 34 on each outer end-wall panel is folded inwardly of the box, all as shown in Fig. 5.

If desired, the material represented by the tongues 34 in the inner panels 17 may be entirely removed in forming the main blank, thus leaving in each panel an opening through which the tongue 34 on the adjacent outer panel 15 can be folded. The arrangement illustrated is preferred, however, as it provides a broader and stronger hand-grip. Moreover, when the particular cover illustrated and described herein is used, the tongue 34 between the panels 15 and 17 has the additional advantage that it maintains a space between the inner and outer end-wall panels and facilitates entrance of tabs 41 when the cover is closed.

To close the egg case, the tabs 41 and 42 on each of the cover-panels 38 are folded downwardly into a position substantially normal to the panel, and the panel is swung downwardly about its associated score line 36. The slots 44 and 45 in the side and end walls of the case receive the tabs 41 and 42, with the result that those tabs enter into the spaces between the inner and outer wall panels. As previously indicated, the width of the tabs 41 and 42 is greater than the width of the slots 44 and 45 so that when the cover is fully closed the tabs extend downwardly below the bottoms of the slots, as indicated in the upper right-hand corner of Fig. 3.

The particular form of cover panels illustrated in the drawing, embodying the tabs 41 and 42, is not essential to my invention. It has the advantage that when the cover is closed all portions thereof lie within the boundaries of the case, thus decreasing the possibility that the cover will be accidentally opened. To facilitate raising either cover when desired, each panel 38 may be provided near its outer end with a finger hole 45. The center dividing partition 37-37 and the two covers 38 may form parts of a single blank, as illustrated in Fig. 2; or, if desired, such blank may be made in two similar parts separated at the center score line 36.

As made and sold by a manufacturer, the main blank shown in Fig. 1 may be left flat in the condition there indicated, in which event the user of the case will secure the flap 47 to the outer edge of the panel 15a as an initial step in erecting the case. Alternatively, the manufacturer may effect such stapling, and the blank thereafter collapsed into substantially a single plane; for the case lacks any definite rectangular shape until the two bottom flaps 23a and 23b have been folded into overlapped relationship and locked together by insertion of the tongues 29. If the manufacturer performs the stapling operation, he may also fold inwardly the inner end-wall panels 17a and 17b, arranging the tongues 34 as indi-

5

cated in Fig. 5 to provide hand holes in the end of the case. To facilitate dismounting of the case, the outer edges of the inner side-wall panels 18 may be provided with finger-receiving notches 46.

My egg case, when erected, is exceptionally durable and rigid. The side, bottom, and end walls are all of double thickness. The length of the slots 32 coupled with the fact that the tongues 30 on the flaps 26a bear for their entire length against the inner faces of the outer side-wall panels results in rigidly maintaining the case in a rectangular shape. At the same time, the case can be shipped and stored in knocked-down condition both before and after its initial use.

I claim as my invention:

An egg-case, comprising a blank of foldable material shaped and foldable to provide inner and outer side-wall panels, inner and outer end-wall panels, and a pair of bottom panels joined respectively to the lower edges of the side-wall panels and foldable into overlapped relation to provide a double-thickness bottom, said inner wall panels being joined to the upper edges of their respective outer wall panels and being foldable inwardly to lie adjacent the inner faces of such outer wall panels, said blank being provided at the lower edges of the outer end-wall panels

6

with flaps having tongues, said bottom panels having aligned slots for the reception of said tongues, and ears on the sides of each tongue, said ears being foldable into superposition with said tongue to permit them to be inserted with the tongue through aligned slots in the bottom panels and foldable outwardly after such insertion to lie against the upper surface of the case bottom, the parts of the blank being so proportioned that the outer edges of said ears will lie adjacent the inner surfaces of the outer side-wall panels to be engaged and held in position by the lower edges of the infolded inner side-wall panels.

HAROLD D. TICHENOR.

REFERENCES CITED

The following references are of record in the file of this patent:

UNITED STATES PATENTS

Number	Name	Date
2,065,482	Verhaven	Dec. 22, 1936
2,087,394	Babinean	July 20, 1937
2,337,755	Lapara	Dec. 28, 1943
2,364,829	Tichenor	Dec. 12, 1944
2,425,230	Cann	Aug. 5, 1947