



- (51) International Patent Classification: Not classified
- (21) International Application Number: PCT/EP2013/052252
- (22) International Filing Date: 5 February 2013 (05.02.2013)
- (25) Filing Language: English
- (26) Publication Language: English
- (30) Priority Data: 1202019.4 6 February 2012 (06.02.2012) GB
- (71) Applicant (for all designated States except US): **KING-FISHER ASIA LIMITED** [—/CN]; 21/F Cornwall House, 979 King's Road, Taikoo Place, Quarry Bay, Hong Kong (CN).
- (72) Inventor; and
- (71) Applicant (for US only): **GIRARD, Martin, Bernard** [FR/CN]; 33 Taitam Road, The Manhattan 28E Taitam, Hong Kong (CN).
- (74) Agents: **BOUBAL, Denis et al.**; 96/98 Boulevard Carnot, F-59027 Lille Cedex (FR).
- (81) Designated States (unless otherwise indicated, for every kind of national protection available): AE, AG, AL, AM, AO, AT, AU, AZ, BA, BB, BG, BH, BN, BR, BW, BY,

BZ, CA, CH, CL, CN, CO, CR, CU, CZ, DE, DK, DM, DO, DZ, EC, EE, EG, ES, FI, GB, GD, GE, GH, GM, GT, HN, HR, HU, ID, IL, IN, IS, JP, KE, KG, KM, KN, KP, KR, KZ, LA, LC, LK, LR, LS, LT, LU, LY, MA, MD, ME, MG, MK, MN, MW, MX, MY, MZ, NA, NG, NI, NO, NZ, OM, PA, PE, PG, PH, PL, PT, QA, RO, RS, RU, RW, SC, SD, SE, SG, SK, SL, SM, ST, SV, SY, TH, TJ, TM, TN, TR, TT, TZ, UA, UG, US, UZ, VC, VN, ZA, ZM, ZW.

- (84) Designated States (unless otherwise indicated, for every kind of regional protection available): ARIPO (BW, GH, GM, KE, LR, LS, MW, MZ, NA, RW, SD, SL, SZ, TZ, UG, ZM, ZW), Eurasian (AM, AZ, BY, KG, KZ, RU, TJ, TM), European (AL, AT, BE, BG, CH, CY, CZ, DE, DK, EE, ES, FI, FR, GB, GR, HR, HU, IE, IS, IT, LT, LU, LV, MC, MK, MT, NL, NO, PL, PT, RO, RS, SE, SI, SK, SM, TR), OAPI (BF, BJ, CF, CG, CI, CM, GA, GN, GQ, GW, ML, MR, NE, SN, TD, TG).

Declarations under Rule 4.17:

— of inventorship (Rule 4.17(iv))

Published:

— without international search report and to be republished upon receipt of that report (Rule 48.2(g))

(54) Title: TILE

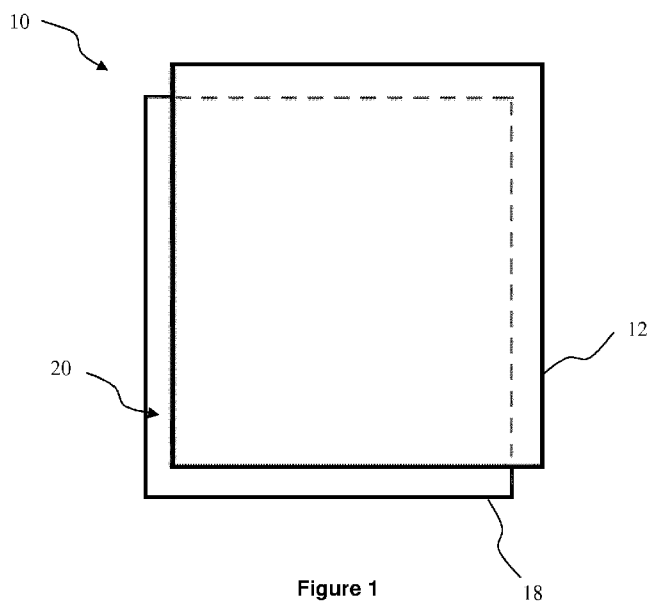

Figure 1

(57) Abstract: The invention relates to a tile for covering a surface, the tile comprising: a base layer comprising a flexible plastic material and including a bottom layer and a middle layer; and a top layer comprising a ceramic material, the top layer being attached to the top surface of the middle layer; wherein the middle layer is attached to the top surface of the bottom layer in an offset relationship such that at least one edge of the middle layer extends beyond the edge of the bottom layer such that a margin on the lower surface of the middle layer is defined and at least one edge of the bottom layer extends beyond the edge of the middle layer such that a margin on the top surface of the bottom layer is defined; wherein at least one of the margins comprises an adhesive material.



TILE

Technical field

- 5 The invention is directed to tiles for covering a surface. In particular the invention is directed towards wall or floor covering tiles comprising a ceramic upper surface.

Background Art

10

Ceramic tiles are widely used as floor and wall coverings. Ceramic tiles can be made from a variety of materials and provide a durable surface and are typically available in a choice of colours and patterns.

- 15 When tiles are installed they are generally laid side by side on a prepared surface such as a floor or wall. Typically an adhesive compound is used as base to attach the tiles to a surface and then grout is spread over and between the tiles to further bind the tiles and to fill in any gaps between the adjacent tiles. This can require experts to be used to install the tiles to ensure the tiles are sufficiently
20 adhered to the floor and each other and to provide an acceptable finished appearance.

The object of the invention is to provide a ceramic tile that can be easily installed.

25 Disclosure of the invention

A first aspect of the invention comprises tile for covering a surface, the tile comprising:

- 30 a base layer comprising a flexible plastic material, and including a bottom layer and a middle layer; and

a top layer comprising a ceramic material, the top layer being attached to the top surface of the middle layer;

wherein the middle layer is attached to the top surface of the bottom layer in an
5 offset relationship such that at least one edge of the middle layer extends beyond
the edge of the bottom layer such that a margin of a lower surface of the middle
layer is defined and at least one edge of the bottom layer extends beyond the
edge of the middle layer such that a margin on the top surface of the bottom layer
is defined;

10

wherein at least one of the margins comprises an adhesive material.

The top layer is connected to the middle layer such that the top layer is in an
offset relationship with regards to the bottom layer such that at least one edge of the
15 top layer extends beyond the edge of the bottom layer and middle layer such that
a margin on the lower surface of the top layer is defined.

In one embodiment the offset relationship is such that at least two edges of the
middle layer and two edges of the top layer extend beyond the edges of the
20 bottom layer and at least two edges of the bottom layer extends beyond the
edges of the middle layer and the top layer.

The dimensions of the bottom layer are larger than the dimensions of the middle
layer and the dimensions of the top layer, and wherein the dimensions of the top
25 layer are larger than the dimensions of the middle layer.

The base layer can comprise PVC. The ratio of the thickness of the top layer to
the base layer can be from 1:1 to 3:1. Preferably the thickness of the top layer is
between 3mm and 5mm.

30

The margins of the bottom layer can comprise an adhesive material. The tile can
further comprise a removable protective layer over the adhesive material.

The middle layer and the bottom layer can be formed as a laminate.

The tile can further comprise an expansion joint.

5

The expansion joint is affixed to the top surface of the bottom layer by an adhesive. The expansion joint has a substantially L shaped cross section. The outer sides of the expansion joint are concave.

10 An adhesive layer can be attached to the bottom of the base layer.

Brief description of the drawing

15 Figure 1 shows a plan view of a tile according to one embodiment of the invention;

Figure 2 shows a cross sectional view of a tile according to the invention;

20 Figure 3 shows a detailed cross sectional view of a portion of two tiles according to the invention;

Figure 4 shows an embodiment of the expansion joint according to the invention;

25 Figure 5 shows a cross sectional view of a portion of a tile according to the invention;

Figure 6 shows a plan view of a floor system comprising a plurality of tiles according to the invention; and

30

Figure 7 shows a plan view of a tile according to one embodiment of the invention.

Modes for carrying out the invention

Figures 1 to 3 show tiles for covering a surface according to a first embodiment of
5 the invention. The tile 10 comprises a decorative top layer 12 and a base layer
14. The base layer 14 comprises a middle layer 16 and bottom layer 18. The top
layer 12 is attached to the top surface of the middle layer 16.

The tile is made from a combination of materials, a rigid material and a flexible
10 material. The top layer 12 comprises a substantially rigid material, such as a
ceramic material. Ceramic materials that can be used include porcelain. The top
layer can be a ceramic tile which is attached to the base layer by a pressure
sensitive glue

15 The base layer 14 comprises a flexible material, such a synthetic plastic material,
preferably a vinyl plastics material such as a polyvinyl chloride (PVC) material.
Being formed from a flexible material allows the base layer to accommodate
unevenness in the surface to be covered.

20 Referring to Figure 2 the base layer 14 is formed from a middle layer 16 and a
bottom layer 18. The middle layer 16 is attached to bottom layer 18 such that the
middle layer 16 is diagonally offset from the bottom layer 18. The middle layer 16
and the bottom layer 18 can be laminated together.

25 In this offset layer arrangement two edges of the middle layer 16 extend an
amount "a" beyond the corresponding edges of the bottom layer 18 while other
two edges of the bottom layer 18 extend beyond the corresponding edges of the
middle layer 16. This defines a substantially L shaped margin 20 around two
edges of the top surface of the bottom layer 18 to which an adhesive can be
30 applied to. While a substantially L shaped margin 22 is defined around two edges
on the bottom surface of the middle layer 16. This L shaped margin 22 of the
middle layer 16 forms an attachment surface.

The top layer 12 is affixed to the base layer 14 in an offset relationship with regards to the bottom layer 18 of the base layer 14. In the offset arrangement two edges of the top layer 12 extend an amount "c" beyond the corresponding edges of the bottom layer 18 of base layer 14 while the other two edges of the bottom layer 18 of the base layer 14 extend an amount "b" beyond the corresponding edges of the top layer 12. This maintains the exposed L shaped margin 20 around two sides of the bottom layer 18 with regards to the top layer. This also defines a margin 24 around the edges of the bottom surface of the top layer 18.

The top layer 12 is affixed to the base layer 14 by an adhesive. The lower surface of the top layer 12 is joined to the top surface of the middle layer 16 of the base layer 14. The top layer 12 is offset from the base layer 14 in the same direction as the middle layer 16 is offset from the bottom layer 18. The top layer 12 has a larger surface area than the middle layer 16 and therefore extends a distance "d" over the edge of the middle layer 16

Each of the layers forming the tile has the same shape but are of different dimensions. The surface area of the top layer 12 is larger than the surface area of the middle layer 16 and the bottom layer 18. The surface area of the bottom layer 18 is larger than the surface area of the middle layer 16. Therefore when the top layer 12 is affixed to the middle layer 16 of the base layer 14 the top surface of the middle layer 16 is not exposed.

Preferably each layer of the tile comprises four sides, preferably with each side of each layer being of substantially equal length. In one preferred embodiment each layer of the tile has the following dimensions:

Top layer 12: 400mm (w) x 400mm (l) x 4.5mm (h)

Middle layer 16: 391mm (w) x 391mm (l) x 1.5mm (h)

Bottom layer: 398mm (w) x 398mm (l) x 1.8 (h)

The size and dimension of the tile can vary depending on the surface to cover and/or the pattern to be created when the tiles are laid.

5

The thickness of the tile, and each layer can vary. Preferably the top layer can have a thickness of from 3mm to 20mm. Preferably the top layer has a thickness of between 3mm to 5mm. Preferably the ratio of the thickness of the top layer 12 to the thickness of the base layer 14 is from 1:1 to 3:1. When thin ceramic tiles are used as the top layer of the tile, the overall thickness of the tile is reduced and allows the tiles to be installed directly on the top of the surface to be covered, for example pre-existing floor or wall coverings. As the middle layer 16 has smaller dimensions than the top layer 12 and bottom layer 18 an indent is formed where the top layer 12 extends over the edges of the middle layer 16 and two edges of the bottom layer 18 extend beyond the two corresponding edges of the top layer 12.

The tile further comprises an expansion joint 26 attached to the margin 20 of the bottom layer 18 of the base layer, such that in use when the tiles are laid adjacent to each other the expansion joint fills the gap between the top layers of adjacent tiles and creates a seal between adjacent tiles.

The expansion joint has a substantially L shaped cross section. The outwardly extending flange portion 28 is adapted to be affixed to a portion of the margin 20 of the top surface of the bottom layer 18. The expansion joint is secured to the bottom layer 18 with an adhesive. The outwardly extending flange 28 extends into the indent between the top layer 12 and the bottom layer 18. The width of the outwardly extending flange portion is narrower than the width of the margin 20. This allows a margin portion to still be defined around the two edges of the bottom layer when the expansion joint is attached to the bottom layer. The height of the outwardly extending flange portion 28 is dimensioned such that it is shorter than the height of the middle layer 16. Therefore a gap 32 is created between the

top surface of the outwardly extending flange portion 28 and the top layer 12.

In one embodiment a portion of the sides of the upwardly extending flange 34 of the expansion joint 26 are substantially concave. Figures 4 and 5 show an example of an expansion joint where the outer sides of the upwardly extending flange 34 are concave. The expansion joint is attached to the top surface of the bottom layer with the outwardly extending flange 28 of the expansion joint located in the indent formed between the bottom layer 18 and the top layer 12. The top edge of the expansion joint contacts the side of the top layer. Either one or both sides of the upwardly extending flange of the expansion joint comprise a concave portion.

The expansion joint can be formed from a flexible material such as a rubber or polyurethane. The expansion joint helps the tile cope with heating and cooling effects of the environment and as well as providing a traditional tiling appearance. Forming the joint from a rubber/polyurethane material means that the expansion joint is able to expand and contract more than the PVC base layer, while the PVC base layer expands and contracts more than the ceramic layer. This helps with manufacturing tolerance issues and allows the tile to expand and contract more safely in response to changes in temperature. The expansion joint is still able to maintain a good appearance for the tiles, like traditional grouting. Having the concave side on the expansion joint can also help with waterproofing of the tiles.

An adhesive material is applied to the exposed margin 20 of the top surface of the bottom layer 18. Preferably a pressure sensitive adhesive is used. For storage of the tiles before installation, the adhesive can be covered with a protective covering which is removed to expose the adhesive when the tiles are about to be laid. Alternatively an adhesive can be applied to the exposed margin 22 of the lower surface of the middle layer 16 with the exposed margin 20 of the bottom layer 18 being the attachment surface. In a further embodiment an adhesive can be applied to the exposed margins 20, 22 of both the middle layer 16 and the bottom layer 18.

Figure 6 shows an example arrangement of four tiles 10 placed together. In order to lay the tiles a first tile is positioned on the surface to be covered. The protective covering is removed from the adhesive. A second tile is then placed adjacent to the first tile such that the side of the top layer 12 of the second tile abuts the expansion joint 26 of the first tile and the attachment surface of the middle layer 16 of the second tile contacts the adhesive on the exposed margin 20 of the bottom layer 18. Because of the offset arrangement and the relative dimensions of the layers when tiles are installed it is two PVC layers 16, 18, that are being joined together to connect adjacent tiles. This allows a better connection between adjacent tiles rather than joining a ceramic layer to a PVC layer to connect adjacent tiles.

Due to the top layer 12 being larger than the bottom layer, when the tiles are installed a gap 34 will be present between the bottom layers 18 of adjacent tiles. The presence of the gap helps with manufacturing tolerance issues and allows the tile to expand and contract in response to changes in temperature.

The tiles are joined together by the adhesive and therefore grouting is not required. This helps to simplify the installation of ceramic tiles. While the expansion joints provides a traditional tiling appearance without the need for grouting

While the tiles have been exemplified as square shaped tiles other shaped tiles are also contemplated by the invention. For example with reference to Figure 7 the tiles 40 can have a substantially rectangular shape, with adjacent sides having different length, or the tiles can have other polygonal shapes which can be fitted together like a puzzle for covering a surface. The tiles can be installed on a variety of surfaces such floors and wall.

In a further embodiment the bottom surface of the bottom layer can comprise an adhesive layer. The adhesive layer may be a silica based double side adhesive

layer. A removeable protective layer can cover the adhesive layer. Where the tiles are to be used for covering a wall surface it is preferred that the base layer comprises the adhesive layer of on the bottom surface. This assists in the affixing the tiles directly to the wall without significant preparation of the surface and
5 avoids the uses of separate adhesive to be applied to the wall to be covered or the back of the tile.

While the tiles are shown with the top layer 12 and the base layer 14 being offset from each other in a diagonal direction such that two edges of the base layer are
10 exposed so as to provide L shaped margins 20, 22, the layers can also be arranged to be offset in a lateral direction. As shown in Figure 7 when offset in a lateral direction only a margin 42 is exposed along only one edge of the top surface of the bottom layer 44 and the lower surface of the top layer 46.

15 Further changes can be made to the described embodiment whilst still remaining within the scope of the invention.

Claims

1. A tile for covering a surface, the tile comprising:

5 a base layer comprising a flexible plastic material and including a bottom layer and a middle layer; and

a top layer comprising a ceramic material, the top layer being attached to the top surface of the middle layer;

10

wherein the middle layer is attached to the top surface of the bottom layer in an offset relationship such that at least one edge of the middle layer extends beyond the edge of the bottom layer such that a margin on the lower surface of the middle layer is defined and at least one edge of the bottom layer extends beyond
15 the edge of the middle layer such that a margin on the top surface of the bottom layer is defined;

wherein at least one of the margins comprises an adhesive material.

20 2. A tile according to claim 1 wherein the top layer is connected to the middle layer such that the top layer is in an offset relationship with regards to the bottom layer such that at least one edge of the top layer extends beyond the edge of the bottom layer and middle layer such that a margin on the lower surface of the top layer is defined.

25

3. A tile according to claim 2 wherein the offset relationship is such that at least two edges of the middle layer and two edges of the top layer extend beyond the edges of the bottom layer and at least two edges of the bottom layer extends beyond the edges of the middle layer and the top layer.

30

4. A tile according to any one of claims 1, 2 or 3 wherein the dimensions of the bottom layer are larger than the dimensions of the middle layer and the

dimensions of the top layer, and wherein the dimensions of the top layer are larger than the dimensions of the middle layer.

5. A tile according to any preceding claim wherein the base layer comprises PVC.

5

6. A tile according to any preceding claim wherein the ratio of the thickness of the top layer to the base layer is between 1:1 to 3:1.

7. A tile according to any preceding claim wherein the thickness of the top layer is between 3mm and 5mm.

10

8. A tile according to any preceding claim wherein the portion of the bottom layer comprises an adhesive material.

9. A tile according to any preceding claim further comprising a removeable protective layer over the adhesive material.

15

10. A tile according to any preceding claim wherein the middle layer and the bottom layer are formed as a laminate.

20

11. A tile according to any preceding claim wherein the tile comprises an expansion joint.

12. A tile according to claim 11 wherein the expansion joint is affixed to the top surface of the bottom layer by an adhesive.

25

13. A tile according to claim 11 or claim 12 wherein the expansion joint has a substantially L shaped cross section.

14. A tile according to any of claims 11 to 13 wherein the sides of the expansion joint are concave.

30

15. A tile according to any preceding claim wherein an adhesive layer is attached to the bottom of the base layer.

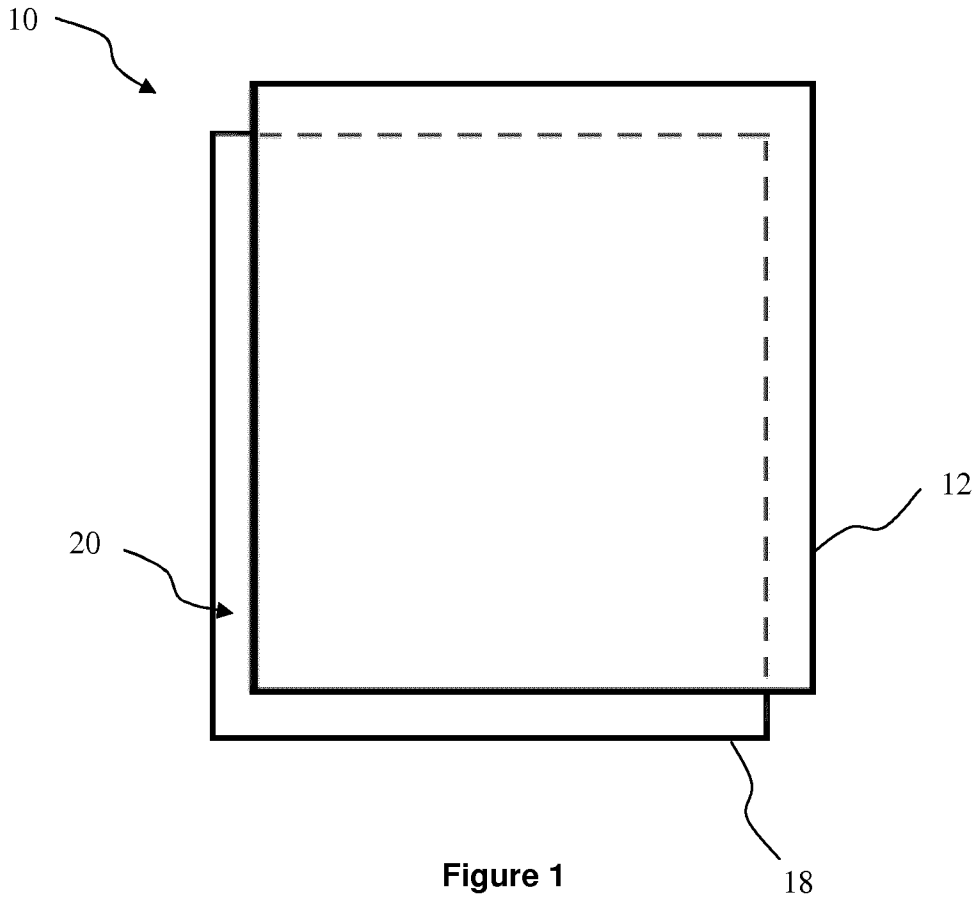

Figure 1

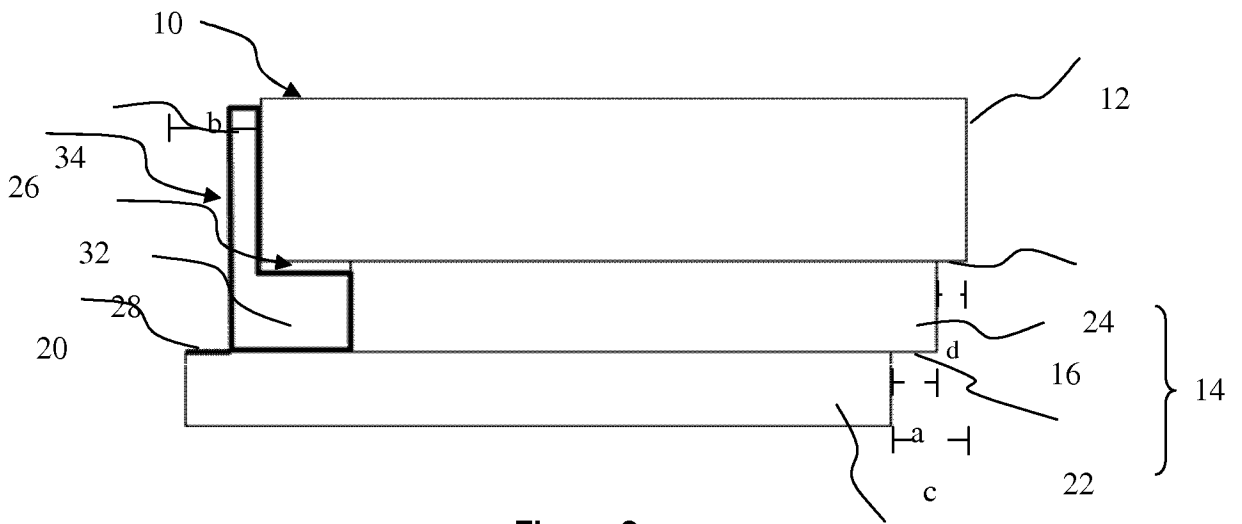
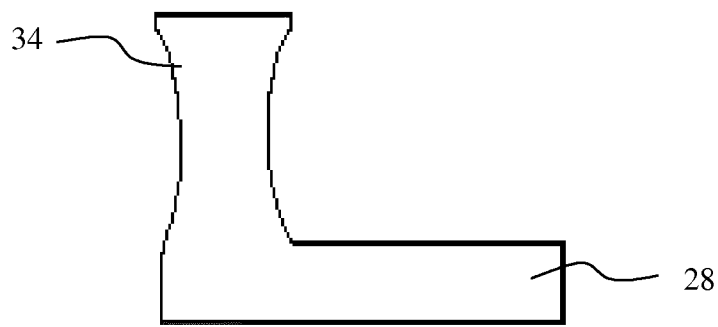
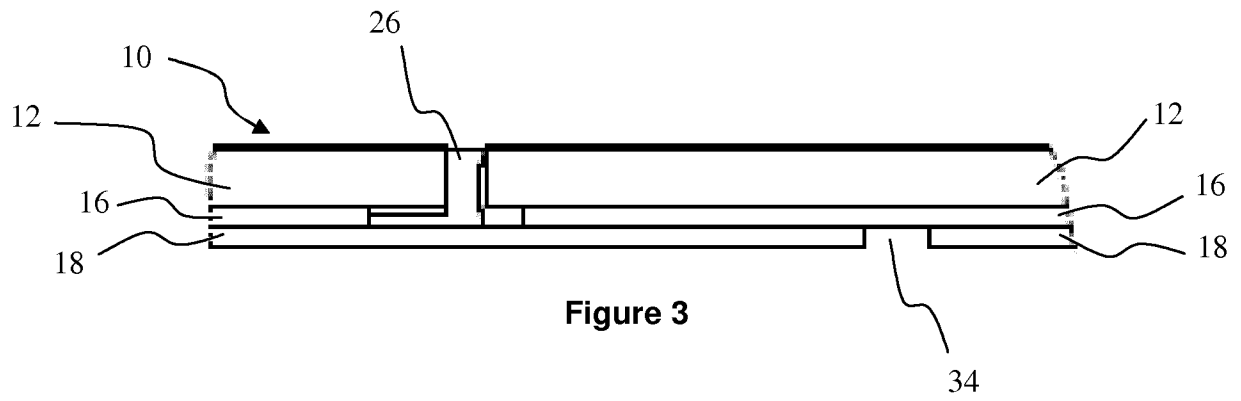

Figure 2

18



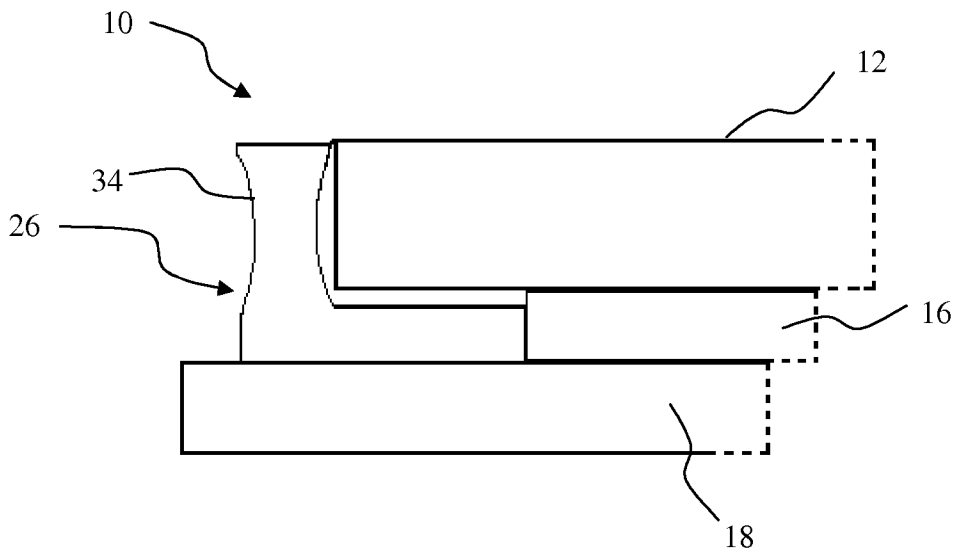

Figure 5

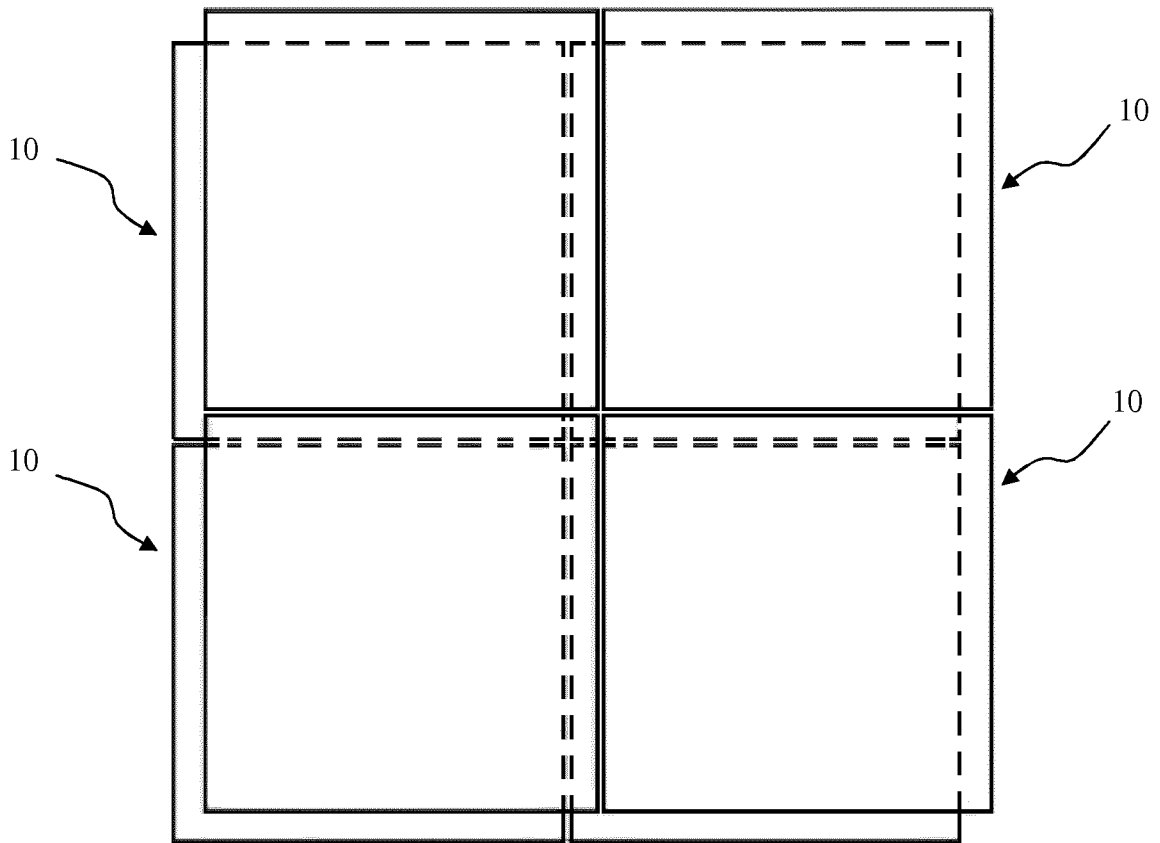

Figure 6



Figure 7