

**(12) PATENT**  
**(19) AUSTRALIAN PATENT OFFICE**

**(11) Application No. AU 199940872 B2**  
**(10) Patent No. 743297**

(54) Title  
**Microstructured separation device**

(51)<sup>7</sup> International Patent Classification(s)  
**B01D 063/08 A61M 001/00**

(21) Application No: **199940872**

(22) Application Date: **1999.05.18**

(87) WIPO No: **WO99/65595**

(30) Priority Data

(31) Number	(32) Date	(33) Country
<b>09/100163</b>	<b>1998.06.18</b>	<b>US</b>

(43) Publication Date : **2000.01.05**

(43) Publication Journal Date : **2000.03.16**

(44) Accepted Journal Date : **2002.01.24**

(71) Applicant(s)  
**3M Innovative Properties Company**

(72) Inventor(s)  
**Thomas I Insley; Raymond P Johnston**

(74) Agent/Attorney  
**DAVIES COLLISON CAVE,GPO Box 3876,SYDNEY NSW 2001**

40872/99



PCT

WORLD INTELLECTUAL PROPERTY ORGANIZATION  
International Bureau

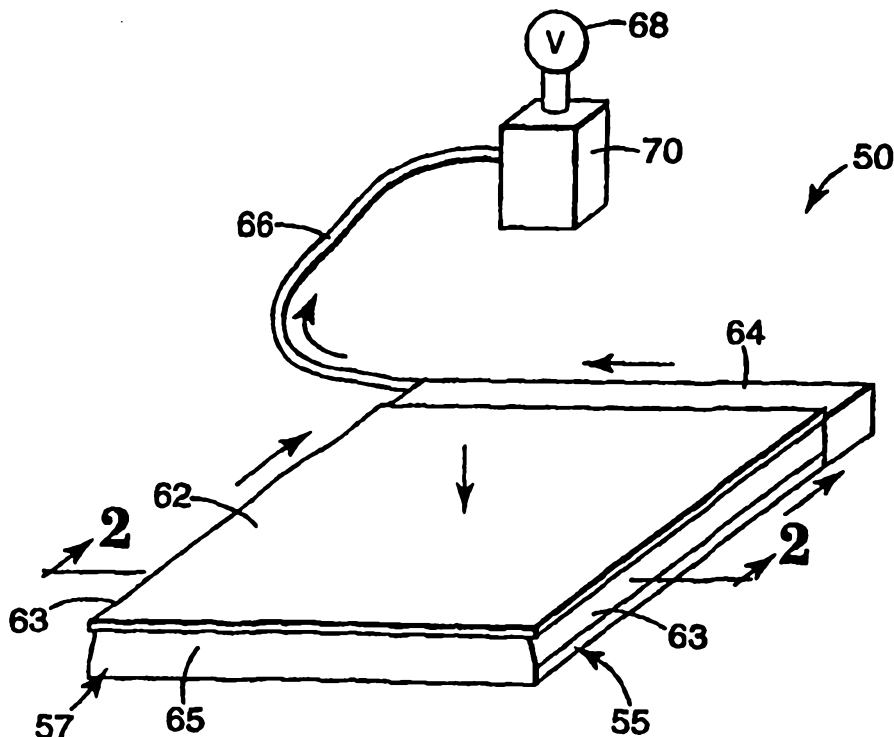
INTERNATIONAL APPLICATION PUBLISHED UNDER THE PATENT COOPERATION TREATY (PCT)

<p>(51) International Patent Classification <sup>6</sup> : <b>B01D 63/08, A61M 1/00</b></p>	<p><b>A1</b></p>	<p>(11) International Publication Number: <b>WO 99/65595</b> (43) International Publication Date: 23 December 1999 (23.12.99)</p>
<p>(21) International Application Number: PCT/US99/11045 (22) International Filing Date: 18 May 1999 (18.05.99) (30) Priority Data: 09/100,163 18 June 1998 (18.06.98) US (71) Applicant: 3M INNOVATIVE PROPERTIES COMPANY [US/US]; 3M Center, P.O. Box 33427, Saint Paul, MN 55133-3427 (US). (72) Inventors: INSLEY, Thomas, I.; P.O. Box 33427, Saint Paul, MN 55133-3427 (US). JOHNSTON, Raymond, P.; P.O. Box 33427, Saint Paul, MN 55133-3427 (US). (74) Agents: ROGERS, James, A. et al.; 3M Innovative Properties Company, Office of Intellectual Property Counsel, P.O. Box 33427, Saint Paul, MN 55133-3427 (US).</p>	<p>(81) Designated States: AE, AL, AM, AT, AU, AZ, BA, BB, BG, BR, BY, CA, CH, CN, CU, CZ, DE, DK, EE, ES, FI, GB, GD, GE, GH, GM, HR, HU, ID, IL, IN, IS, JP, KE, KG, KP, KR, KZ, LC, LK, LR, LS, LT, LU, LV, MD, MG, MK, MN, MW, MX, NO, NZ, PL, PT, RO, RU, SD, SE, SG, SI, SK, SL, TJ, TM, TR, TT, UA, UG, UZ, VN, YU, ZA, ZW, ARIPO patent (GH, GM, KE, LS, MW, SD, SL, SZ, UG, ZW), Eurasian patent (AM, AZ, BY, KG, KZ, MD, RU, TJ, TM), European patent (AT, BE, CH, CY, DE, DK, ES, FI, FR, GB, GR, IE, IT, LU, MC, NL, PT, SE), OAPI patent (BF, BJ, CF, CG, CI, CM, GA, GN, GW, ML, MR, NE, SN, TD, TG).</p> <p><b>Published</b> <i>With international search report.</i></p>	

(54) Title: MICROSTRUCTURED SEPARATION DEVICE

(57) Abstract

An active fluid separation device for removing a constituent of a fluid mixture. The separation device formed from a first polymeric structured layer having a plurality of flow channels defined in one surface, and a selectively permeable fluid separation media covering at least some of the flow channels. An external source is also included to provide a potential over the flow channels to promote movement of the fluid through the separation media, thereby removing a constituent component of the fluid mixture. A manifold in fluid contact with the flow channels of the structured layer may also be used to operatively permit the source to provide the potential over the flow channels.



## MICROSTRUCTURED SEPARATION DEVICE

The present invention relates to a separation device comprising a selectively permeable separation medium bonded to a microstructured film that is used in connection with a source for driving a fluid mixture through the device.

Fluid separation devices remove a constituent from a fluid mixture by passing the fluid mixture through a selectively permeable separation medium. The undesirable component(s) of the fluid mixture remain on one side of the separation medium, and the permeable component(s) pass through to the other side of the separation medium. Types of separations possible with such devices include gas-solid, gas-gas, gas-liquid, liquid-liquid, and liquid-gas. Applications using these types of separations include water desalinization, dialysis, ultrafiltration to remove bacteria and other fine particles, detoxification of industrial effluents, sewage treatment, and ultrafiltration to remove very fine or dissolved solids from liquids or gases. Typically, these fluid separation devices are at least partially submerged or flooded within the fluid mixture during the separation process.

Transport and control of a fluid mixture through a selectively permeable separation medium may be achieved in a separation system by a fluid transport mechanism independent of the separation medium. An example of this type of system includes a pumping system wherein the fluid mixture is pumped from one tank through a separation medium into another tank. On the other hand, transport and control of the fluid mixture may be achieved as part of a separation device, wherein a separation medium is coupled to a fluid transport mechanism. For example, the separation device may include a vacuum distribution mechanism coupled to a separation medium for driving the fluid mixture through the separation medium by a vacuum source.

The transport of fluid by a conduit or other device may be characterized based on the mechanism that causes flow within the conduit or device. Where fluid transport pertains to a nonspontaneous fluid flow regime wherein the fluid flow results, for the most part, from an external force applied to the device, such fluid transport mechanism is considered active. On the other hand, where the fluid transport pertains to a spontaneous flow regime wherein the fluid movement stems from a property inherent to the transport device, such fluid transport mechanism is considered passive. A catheter is a well-known

example of an active fluid transport device. Typically, catheters that are used in the medical field to drain fluid from a body cavity are connected to a vacuum source to draw the liquid through the device. A passive fluid transport device is an absorbent pad.

Active fluid transport products have been developed based upon specific applications, including absorbent pads or a liquid pervious layer combined with fluid transport devices. For example, mat products including active fluid transport and absorbent pads or liquid pervious layers are described in U.S. Patent Nos. 5,437,651 to Todd et al., and 5,349,965 to McCarver. In each case, channels are defined on a surface of a substrate to direct liquid flow from substantially all of the area of a liquid pervious layer. These products remove liquid while having the liquid pervious layer act as a liquid absorbing and storing layer and/or to define a liquid receiving chamber. In Todd et al., a flexible backing plate is attached to an absorbent portion, and a suction source is applied to the backing plate. The backing plate comprises a plurality of channels for directing the vacuum provided by the suction source more evenly across the surface of the absorbent portion. In McCarver, a flexible pad or suction rail having a liquid permeable top surface and a liquid impermeable bottom surface is connected to a vacuum source. The suction draws liquid down into a liquid receiving chamber as it passes through the liquid pervious layer, and draws the accumulated liquid away. The liquid receiving chamber contains separation means dividing the chamber into channels for keeping the chamber from collapsing when the chamber is placed under a negative pressure.

Another flexible fluid transport product has been recently introduced and is commercially available under the tradename "Fluid Control" floor suction mat, from Technol Medical Products Inc. This product is used to absorb fluids that fall from a surgical site during a surgical procedure. The device has an absorbent mat that resides above a multitude of parallel enclosed channels. Holes are provided in the channel surfaces that interface with the absorbent mat so that fluid recovered by the mat can be drawn into the channels. The parallel channels are connected to a manifold for attachment with suction tubing. Thus, after fluid has accumulated within the mat, removal thereof can be facilitated through the multiple channels by the application of vacuum.

Examples of flexible fluid transport devices that utilize both active and passive fluid transport are described in U.S. Patent Nos. 3,520,300 to Flower, 4,747,166 to Kuntz,

and 5,628,735 to Skow. In Flower, a surgical sponge and suction device is disclosed having an absorbent material over a perforated wall of a chamber that is connected to a vacuum source via a tube. In Kuntz, a pad, having an absorbent core encased in hydrophobic material but with a perforated top surface, surrounds a perforated tube  
5 coupled to a vacuum source. In Skow, a mat is provided comprising a material having a high wicking property, and within the material, a flexible suction tube is provided for preventing the mat from becoming saturated with fluid. In all three cases, the tubing limits where the fluid is evacuated from within the device.

Examples of other channeled mats for fluid removal are shown in U.S. Patent Nos.  
10 4,533,352 to Van Beek et al. and 4,679,590 to Hergenroeder; however, these mats provide structure for receiving fluid without defining a receiving chamber closed by a liquid pervious layer. Van Beek et al. shows a ribbed mat with a centrally located suction hose connected to the ribs by openings in the hose. Hergenroeder shows a mat having a gridwork of small basins forming a collection surface that are drained into channels  
15 connected to a suction source.

Examples of passive fluid transport devices having channeled fluid transport structures are described in PCT International Publication No. WO 93/11727, entitled "Liquid Management Member For Absorbent Articles." Disclosed is the use of a liquid management member having a microstructure-bearing hydrophilic surface, preferably in  
20 combination with a liquid permeable top sheet, a back sheet, and an absorbent core disposed between the top and back sheets. The liquid management member promotes rapid directional spreading of liquids and is in contact with the absorbent core.

Specific examples of fluid separation devices include the type disclosed in U.S. Patent No. 5,455,771 to Degen. In the Degen patent, a collection of fine, hollow, permeable or semi-permeable fiber strands are used as a fluid transport device. These  
25 hollow fibers may filter a fluid by passing it over the exterior of the fibers and/or by passing the fluid through the fiber walls and into the interior of the fibers. Problems associated with these types of separation devices include problems with the production of the fibers. Moreover, hollow fiber separation devices are limited in application and  
30 susceptible to a number of problems. Fiber fragility and the general difficulty of handling bundles of small individual elements hampers their use. High unit cost, fouling, and a lack

of geometric (profile) flexibility further limit application of these fibers as a fluid transport mechanism in separation devices. The inability to practically distribute long lengths and large numbers of hollow fibers into useful transport arrays makes their use inappropriate for all but a limited range of active fluid transport applications.

5           The present invention overcomes the disadvantages and shortcomings of the prior art by providing a separation device that is flexible, efficient, easy to handle and use, inexpensive to manufacture, and extremely versatile and adaptable to various separation applications. More specifically, the present invention provides a separation device comprising a separation module formed from a structured layer having a plurality of flow  
10 channels and a separation media, as well as a source providing a potential across the flow channels of the structured layer to drive a fluid mixture through the separation media in order to remove a constituent(s) from the fluid mixture.

The separation module preferably includes a manifold connected in fluid contact with the flow channels of the structured surface. The manifold may be connected to the  
15 source, or may be connected to a receptacle or to another device. The source provided as part of the separation device may connect to the manifold, or may connect to the separation module in some other manner. The source may be a vacuum that pulls a fluid mixture through the separation media, into the flow channels and out through the manifold, or it may pull a fluid mixture through the manifold, into the flow channels and  
20 across the separation media. Alternatively, the source may be a pressure source, such as a pump, that pushes the fluid mixture through the separation media in either direction discussed above.

The separation media comprises selectively permeable separation material, such as microporous film, micro-perforated film, nonwoven filtration web, or other types of  
25 filtration material. The separation module may be formed with a single layer of separation media, or it may have multiple layers that are all the same, or are different from one another, depending on the separation application.

The flow channels of the structured layer are defined by a series of peaks whose sidewalls may converge, or that may be separated by a planar floor. Alternatively, the  
30 peaks may be separated by at least one sub-peak forming sub-channels within each flow channel. The flow channels may vary across the structured surface, channel to channel, or

within each channel. The structured surface may be formed from a polymer such as polytetrafluoroethylene or polypropylene, or other suitable material.

In another embodiment, the separation module may comprise more than one structured layer at least partially covered by a separation media. A manifold in fluid  
5 contact with the flow channels of the first layer would also be in fluid contact with the flow channels of at least one other layer.

The present invention also teaches a method of removing a constituent from a fluid mixture comprising the steps of providing a separation module of the present invention, connecting the module to an externally provided source to form the separation device,  
10 flooding the module within a fluid mixture to be filtered, and driving the fluid mixture through the module by the source, thereby removing a constituent(s) from the fluid mixture. This method may also encompass a source that is a vacuum or a source that is a pressure source. The method may drive the fluid mixture through a manifold into the flow channels of the structured layer and across the separation media, or it may drive fluid  
15 through the separation media into the flow channels and out through the manifold. The separation module of the method may have a single separation media layer, or it may include multiple separation media layers that are either the same or different from one another.

Figure 1 is a perspective view of a separation device in accordance with the present  
20 invention using a vacuum source to drive a fluid mixture;

Figure 2 is a cross-sectional view taken along line 2-2 of the separation device of Figure 1;

Figure 3 is a perspective view of a separation module in accordance with the present invention having a nonwoven web for a separation media;

25 Figure 4 is a cross-sectional view of a separation module in accordance with the present invention having multiple separation media layers;

Figure 5 is an end view of a structured layer illustrating another channel configuration in accordance with the present invention;

30 Figure 6 is an end view of a structured layer illustrating yet another channel configuration in accordance with the present invention;

Figure 7 is a top view of a structured layer illustrating one channel layout configuration in accordance with the present invention;

Figure 8 is a top view of a structured layer illustrating another channel layout configuration in accordance with the present invention;

5 Figure 9 is a top view of a structured layer illustrating yet another channel layout configuration in accordance with the present invention;

Figure 10 is a perspective view of a separation module in accordance with the present invention submerged in a fluid mixture within a container;

10 Figure 11 is a perspective view of multiple separation modules having a common manifold in accordance with the present invention submerged in a fluid mixture within a container;

Figure 12 is a perspective view of a separation device in accordance with the present invention using a pressure source to drive a fluid mixture; and

15 Figure 13 is a perspective view of a separation device in accordance with the present invention using a pressure differential through a separation cover to drive a fluid mixture.

With reference to the attached Figures, like components are labeled with like numerals throughout the several Figures. Figures 1 and 2 illustrate a separation device 50 in accordance with the present invention. Figure 2 is a cross sectional view of the  
20 separation device 50 taken along line 2-2 of Figure 1. The separation device 50 basically includes a separation module 55 connected to a source 68. The separation module 55 has a structured layer 57 having a structured surface 58 on one of its two major surfaces. The structured surface 58 comprises a plurality of channels 59 formed within the layer 57, preferably as shown in a consistent, ordered manner. Each channel 59 need not be the  
25 same as another of the layer 57, but the channels 59 are preferably ordered in the sense that each channel 59 is set by a predetermined design of the structured surface 58 of layer 57.

The layer 57 may comprise flexible, semi-rigid, or rigid material, which may be chosen depending on the particular application of the separation device 50. Preferably, the layer 57 comprises a polymeric material because such material is typically less expensive  
30 and because such polymeric material can be accurately formed with a structured surface 58. Moreover, by the use of a polymeric layer 57 in the form of, for example, a film layer

can provide a structured surface defining a large number of and high density of fluid flow channels 59 on a major surface thereof. Thus, a highly efficient, inexpensive separation device of the present invention is amenable to being manufactured with a high level of accuracy and economy.

5           As shown in Figure 2, the channels 59 of layer 57 are defined by a series of peaks 60 formed of sidewalls 61. In some cases, it will be desirable to extend the peaks 60 entirely from one edge of the layer 57 to another; although, for other applications, it may be desirable to extend the peaks 60 only along a portion of the structured surface 58. That is, channels 59 that are defined between peaks 60 may extend entirely from one edge to  
10 another edge of the layer 57, or such channels 59 may only be defined to extend over a portion of the layer 57. One or more channel portions may begin from an edge of the layer 57, or may be entirely intermediately provided within the structured surface 58 of the layer 57.

The separation module 55 also includes a selectively permeable separation media  
15 62 covering at least a portion of, but preferably all of, the structured layer 57. Each of the channels 59 may be, but need not be, closed off at one end and covered by the separation media 62 so that all of the fluid mixture that is run through the separation module 55 will pass through the separation media 62. Preferably, the separation media 62 is bonded or otherwise sealed to the structured layer 57 along the two sides 63 that are parallel to the  
20 channels 59, as well as along one end 65. The separation media 62 may also be bonded to the structured layer 57 at the peaks 60 of the channels 59, if desired.

The selectively permeable separation media 62 can be chosen to remove desired constituents from a fluid mixture as the fluid mixture passes through the separation media 62. The separation media 62 may be any of a number of types of filtration media  
25 including, without limitation, microporous films, micro-perforated films, nonwoven webs, woven webs, microporous foams, a stacked microstructure filtration media as shown and described in commonly owned co-pending Application Serial No. 09/106,506, to Insley et al. filed on the same date as this case and entitled "Structured Surface Filtration Media", and the like. An embodiment of a separation module 55 of the present invention wherein  
30 the separation media 62 is a nonwoven web 75 sealed at one end 76, is shown in Figure 3. Such a seal may be accomplished by head pressure sealing the edge of the nonwoven web

75 to an edge of the structured layer 57, in which case, the structured surface 58 at the edge may be crushed. Other adhesives or sealants could be used instead or in combination.

The separation media 62 that is to be used for a given application will depend on the requirements of the separation, such as gas-solid, gas-liquid, liquid-solid, or liquid-liquid. Multiple layers of separation media 62, 72 and 74 may also be used in a given embodiment in order to meet the separation requirements of the application, as illustrated in Figure 4. These separation media 62, 72 and 74 may all be the same, or may all be different, or may have some the same and some different, depending on what the requirements of the various separation media are, such as increased separation capacity and/or multiple constituent removal.

Alternatively, the separation media 62 may be removable and replaceable with respect to the separation module 55. By removably mounting the separation module 62, instead of permanent bonding or otherwise permanently sealing it, to the structured layer 58 the separation media 62 may be replaced by the same type of or a different type of separation media material. The separation module 55 may then be reused for another fluid separation process, or may continue to be used in the same process.

In addition, the separation module 55 also preferably includes a manifold 64 or 64' (See Figures 1 and 3, respectively) coupled to at least a plurality of the channels 59 of the structured layer 57, and preferably coupled, as shown in these embodiments, to the separation media 62 at a common side, so that a majority of the discrete flow channels 59 are in fluid contact with the manifold 64. The manifold 64 or 64' preferably is in fluid communication with each of the channels 59 through outlets (not shown) thereof, and is provided with a plenum (not shown) that is defined internally therein and which is in fluid communication with channels 59. The plenum may simply comprise a chamber within the manifold 64 that is sealingly connected to at least a plurality of the channels 59. The manifold 64 may be flexible, semi-rigid, or rigid, like the layer 57. Moreover, a second manifold or more may also be provided on the other side of layer 57, as illustrated in Figure 13 (and discussed in detail below), depending on the particular application.

However, the manifold 64 may connect only to the channels 59 and not to the separation media by excluding the separation media from contact with the plenum, or by

the addition of a impermeable cover layer bonded to the structured layer between the manifold and the separation media. This cover layer would then form flow passages in a portion of the structured layer where fluid is transported between a port open to the plenum and another port open to the separation media. The manifold may couple to the  
5 flow channels at the end of the structured layer, or it may couple to the flow channels on top of the structured surface, or in any other manner suitable for providing fluid contact between the manifold and the flow channels. Alternatively, the channels may connect to a central passage, such as those shown in Figures 7-9 (and discussed below), or they may connect directly to a source without the use of a manifold.

10 The separation device creates an active fluid flow that operates by a source 68 producing a potential over the flow channels 59. The potential source may comprise any means that provides a potential difference across a plurality of the flow channels 59 from a first potential to a second potential, except for gravitational forces alone. The potential difference should be sufficient to cause, or assist in causing, fluid flow through the plural  
15 flow channels 59, which is based in part on the fluid characteristics of any particular application. As shown in Figure 1, the potential source 68 may comprise a vacuum generator that is conventionally connected with a collector receptacle 70. The collector receptacle 70 is fluidically connected with the manifold 64 by way of a conventional flexible tube 66. Thus, by the provision of a vacuum at the source 68, a fluid or fluid  
20 mixture can be drawn from outside the separation module 55 through the separation media 62 and into the channels 59. The filtered fluid, or filtrate, then flows from the flow channels 59 out through the manifold 64 and through tube 66 into the collection receptacle 70. The receptacle 70 may advantageously be openable to permit the filtrate to be removed therefrom for other use and/or processing, or may be otherwise connected with  
25 conventional drainage systems or mechanisms.

In the case where the potential source 68 comprises a vacuum generator, the vacuum provided to the channels 59 via manifold 64 may be sufficient to adequately hold the separation media 62 against the structured surface 58. That is, the vacuum itself will tend to hold the separation media 62 against peaks 60 of the structured surface 58. Thus,  
30 the potential provided from an external source can be more effectively and efficiently distributed over the structured surface 58 of layer 57.

Other potential sources 68 are useable in accordance with the present invention instead of or in conjunction with a vacuum generation device. Generally, any manner of causing fluid flow through the channels 59 is contemplated except based purely on gravitational forces. That is, any external device that causes fluid to be transported  
5 through the channels 59 is contemplated. Examples of other potential sources include but are not limited to, vacuum pumps, pressure pumps and pressure systems, magnetic systems, magneto hydrodynamic drives, acoustic flow systems, centrifugal spinning and any other known or developed fluid drive system utilizing the creation of a potential difference that causes fluid flow to at least to some degree.

10 Although the embodiment of Figures 1, 2 and 4 is shown with structured surfaces 57 comprising multiple peaks 60 whose sidewalls 61 of each successive peak 60 converge to define a line at the base of the channel 59, other channel configurations are contemplated. A specific application for the separation device 50 may determine the number, type and size of the channels 59 provided to meet the separation requirements.  
15 For example in Figure 5, the channels 87 are defined by a continuous series of peaks 86 which are separated by a wide, flat floor 89. Each peak 86 is flattened at the top, thereby facilitating bonding with an adjacent layer, such as the separation media 62. Each peak 86 could also be pointed, if desired. In Figure 6, wide channels 92 are defined between peaks 91, but instead of providing a planar floor between channel sidewalls 93, a plurality of  
20 smaller sub-peaks 94 are provided. These sub-peaks 94 thus define secondary channels 95 therebetween. Sub-peaks 94 may or may not rise to the same level as peaks 91, and as illustrated, create a first wide channel 92 including smaller channels 95 distributed therein. The peaks 91 and sub-peaks 94 need not be evenly distributed with respect to themselves or each other. The smaller channels 95 can be used, for example, to control fluid flow  
25 through the wider channels 92.

Although Figures 1 - 6 contemplate elongated, linearly-configured channels, the channels may be provided in many other configurations. For example, the channels could have varying cross-sectional widths along the channel length; that is, the channels could diverge and/or converge along the length of the channel. The channel sidewalls could also  
30 be contoured rather than being straight in the direction of extension of the channel, or in the channel height. Generally, any channel configuration that can provide at least multiple

discrete channel portions that extend from a first point to a second point within the separation device are contemplated.

In Figure 7, a channel configuration is illustrated in plan view that may be applied to the layer 57 to define the structured surface 58. As shown, plural converging channels  
5 100 can be provided for intermediate collection of fluid and that are further connected with a single discrete channel 102. This minimizes the provision of outlet ports to one. As shown in Figures 8 and 9, a central channel 103 or 105 may be connected with a plurality of channel branches 102 or 104 that may be designed to cover a particular surface area of the structured surface for removing fluid from that particular area. Again, generally any  
10 pattern is contemplated in accordance with the present invention as long as a plurality of discrete channels are provided over a portion of the structured surface 58 from a first point to a second point. The aim of the channel pattern is to distribute the potential across the surface area of the separation media 62 in order to efficiently utilize the separation media 62 in separating constituents from a fluid mixture as it passes through the separation media  
15 62.

As to any of the channels 59 contemplated above and in accordance with the present invention, such channels 59 are defined within layer 57 by the structured surface 58 of a first major surface of the layer 57. The channels in accordance with the present invention are configured to be discrete to allow any one channel to receive fluid from the  
20 ambient environment independently of the other channels. The microstructured size of each channel encourages single-phase flow. Without having air entrained in the liquid, noise generation is significantly reduced and less stress can be placed on liquids that are transported through the active fluid transport device.

The individual flow channels of the microstructured surfaces of the invention are  
25 substantially discrete. That is, fluid can move through the channels independent of fluid in adjacent channels. The channels independently accommodate the potential relative to one another to direct a fluid along or through a particular channel independent of adjacent channels. Preferably, fluid that enters one flow channel does not, to any significant degree, enter an adjacent channel, although there may be some diffusion between adjacent  
30 channels. It is important to effectively maintain the discreteness of the micro-channels in order to effectively transport the fluid and maintain advantages that such channels provide.

Not all of the channels, however, may need to be discrete for all embodiments. Some channels may be discrete while others are not. Additionally, channel "discreteness" may be a temporary phenomenon driven, for example, by fluctuating pressures.

As used here, aspect ratio means the ratio of a channel's length to its hydraulic radius, and hydraulic radius is the wettable cross-sectional area of a channel divided by its wettable channel circumference. Preferably, the structured surface 58 is a microstructured surface that defines discrete flow channels that have a minimum aspect ratio (length/hydraulic radius) of 10:1, in some embodiments exceeding approximately 100:1, and in other embodiments at least about 1000:1. At the top end, the aspect ratio could be indefinitely high but generally would be less than about 1,000,000:1. The hydraulic radius of a channel is no greater than about 300  $\mu$ m. In many embodiments, it can be less than 100  $\mu$ m, and may be less than 10  $\mu$ m. Although smaller is generally better for many applications (and the hydraulic radius could be submicron in size), the hydraulic radius typically would not be less than 1  $\mu$ m for most embodiments. As more fully described below, channels defined within these parameters can provide efficient bulk fluid transport through an active fluid transport device.

The structured surface 58 can also be provided with a very low profile. Thus, active fluid transport devices are contemplated where the structured polymeric layer has a thickness of less than 5000 micrometers, and even possibly less than 1500 micrometers. To do this, the channels may be defined by peaks that have a height of approximately 5 to 1200 micrometers and that have a peak distance of about 10 to 2000 micrometers.

Microstructured surfaces in accordance with the present invention provide flow systems in which the volume of the system is highly distributed. That is, the fluid volume that passes through such flow systems is distributed over a large area. Microstructure channel density from about 10 per lineal cm (25/in) and up to one thousand per lineal cm (2500/in) (measured across the channels) provide for high fluid transport rates. Generally, when a common manifold is employed, each individual channel has an aspect ratio that is at least 400 percent greater, and more preferably is at least 900 percent greater than a manifold that is disposed at the channel inlets and outlets. This significant increase in aspect ratio distributes the potential's effect to contribute to the noted benefits of the invention.

Figure 10 illustrates an embodiment of an immersible flexible separation module 110 in accordance with the present invention used to remove constituents from a fluid mixture 119 held in a container 118. The separation module 110 has a flexible structured layer 111 and a flexible separation media 112 coupled to a flexible manifold 114, thereby providing fluid connection between the flow channels (not shown) of the structured surface 111 and the manifold 114. Preferably, layers 111 and 112 are sealed together at all sides and to the manifold 114. Thus, the edges of the separation module 110 are closed so that flow of the fluid mixture 119 goes through the separation media 112, into the channels (not shown) of the structured layer 111, and out through the manifold 114. A flexible hose 116 connects the manifold 114 to an external source (not shown). A source, such as a vacuum, is provided to cause flow through the hose 116 and manifold 114, so that the fluid mixture 119 passes through the separation media 112 for removing constituent(s) from the fluid mixture 119. The filtered fluid then flows along the flow channels (not shown) of the structured layer 111 into the manifold 114 and out the hose 116 to a reservoir or other receptacle (not shown). By being flexible, the separation module 110 may conform to a surface of the container 118, such as a wall or floor, thereby improving the separation device's ability to efficiently perform the separation process. Being immersible, the separation module 110 may be submerged in any desired fluid mixture in order to facilitate effective constituent removal from the fluid mixture. In addition, the flat, large surface area of the module effectively uses the filter separation media's filtering capacity by spreading the intake of the fluid mixture across the entire surface area of the separation media. Although the separation module 110 need only be partially submerged, it is preferably completely submerged to most efficiently filter a bulk fluid mixture.

In order to increase the capacity of a separation device 50, the size of a separation module 110 could be increased. However, when size increases are limited due to container 118 size or configuration, a plurality of separation modules 110, 120 and 121 could be combined on a common manifold 114 to increase separation capacity instead, as illustrated in Figure 11. Again, flexibility of the separation modules improves the separation device's ability to efficiently perform the separation process. In addition, a plurality of independent separation modules 110, that is separation modules having individual manifolds from a common source, or even individual separation modules having different

sources, could also be employed in a single container 118, or a plurality of separation modules 110, 120, 121 on a common manifold could be placed in separate containers.

Another method of increasing separation capacity of a separation device 50 or separating more than one constituent from a fluid mixture, aside from increasing the number of layers of separation media 62 employed in the separation module 55, would be to pass a fluid mixture through a series of separation modules 55. These modules 55 may have different separation media 62 or they may have the same separation media 62, depending on the requirements of the separation process being performed. Various methods that are known or developed may be used to perform the separation process through a series of separation modules 55, including the use of a series of separation devices 50 wherein the separation module 55 of one is placed within the receptacle 70 of another.

An alternate embodiment of a separation device 130 of the present invention is shown in Figure 12, wherein the source 142 comprises a pressure pump. In this embodiment, the pump 142 transports a fluid mixture from a reservoir 144 under pressure through a flexible hose 140 and into an internal chamber (not shown) of a manifold 138. From the manifold 138, the fluid mixture is transported through the flow channels (not shown) of the structured surface 134 of separation module 132, and then out through the separation media 136. The filtered fluid may be output from the separation module 132 into the environment, or into a container (not shown) or other suitable receptacle. For this embodiment, the cross-sectional view shown in Figure 2, taken along line 2-2 of Figure 12, also applies. Other channel configurations, as discussed above, may also be used in this present device. A separation device 130 of this embodiment could be used in conjunction with a separation device 50 of the prior embodiment, shown in Figure 1, for performing a series of separations, or other processes. A separation device 130 of this embodiment may also be combined with one or more separation devices of the same or different embodiments, as required. The descriptions of the separation device components given above apply equally to the components of this device 130.

Another alternate embodiment of a separation device 150 in accordance with the present invention is illustrated in Figure 13. This embodiment differs from the other embodiments previously described in that a source (not shown) provides a potential over

the separation module 151 through a separation cover 160. The separation cover 160 defines a chamber (not shown) and preferably fully encloses the separation media 154 to provide fluid communication between the source and the separation media 154 of the separation module 151. An inlet 162 connects the internal chamber of the separation cover 160 to the source, preferably by way of a conduit (not shown). This separation module 151 also comprises a manifold 156 that is in fluid communication with the flow channels of the structured surface 152, in the same manner described above for other embodiments. In addition, an optional second manifold 158 is shown in fluid communication with the flow channels of the structured surface 154 on the opposite side of the separation module 151 than the first manifold 156.

When the source is a pressure source, a fluid mixture is provided from the source and flows through the inlet 162 into the internal chamber of the separation cover 160, and then through the separation media 154. The filtered fluid is transported from the separation media 154, through the flow channels of the structured surface 152, into the manifolds 156, 158, and out to a receptacle, the environment, or other suitable area. When the source is a vacuum source connected to the inlet 162 of the separation cover 160, a fluid mixture is pulled into the manifolds 156, 158 by suction from a suitable container, or the like. If no manifolds are provided, fluid mixture could enter one or all of one or more sides of the structured layer 152. The fluid mixture is then transported into the flow channels of the structured layer 152, and through the separation media 154. The filtered fluid then flows into the internal chamber of the separation cover 160 and out through the inlet 162 to a receptacle (not shown), or other suitable location. Alternatively, the vacuum source may be connected to the separation module 151 at the manifolds 156, 158, so that a fluid mixture is pulled from a reservoir (not shown) connected to the inlet 162 of the separation cover 160. The fluid mixture would then be transported into the internal chamber of the separation cover 160 and on into the flow channels of the structured layer 152, by way of the separation media 154. The filtered fluid would then flows into the manifold and out through a connecting conduit (not shown) to a receptacle (not shown), or other suitable location. As with the other embodiments of the present invention, this separation device 150 may be combined with one or more separation devices of the same

or different embodiments. The descriptions of the separation device components given above apply equally to the components of this device 150.

The making of structured surfaces, and in particular microstructured surfaces, on a polymeric layer such as a polymeric film are disclosed in U.S. Patent Nos. 5,069,403 and 5,133,516, both to Marentic et al. Structured layers may also be continuously microreplicated using the principles or steps described in U.S. Patent 5,691,846 to Benson, Jr. et al. Other patents that describe microstructured surfaces include U.S. Patent 5,514,120 to Johnston et al., 5,158,557 to Noreen et al., 5,175,030 to Lu et al., and 4,668,558 to Barber.

10 Structured polymeric layers produced in accordance with such techniques can be microreplicated. The provision of microreplicated structured layers is beneficial because the surfaces can be mass produced without substantial variation from product-to-product and without using relatively complicated processing techniques. "Microreplication" or "microreplicated" means the production of a microstructured surface through a process 15 where the structured surface features retain an individual feature fidelity during manufacture, from product-to-product, that varies no more than about 50  $\mu\text{m}$ . The microreplicated surfaces preferably are produced such that the structured surface features retain an individual feature fidelity during manufacture, from product-to-product, which varies no more than 25  $\mu\text{m}$ .

20 In accordance with the present invention, a microstructured surface comprises a surface with a topography (the surface features of an object, place or region thereof) that has individual feature fidelity that is maintained with a resolution of between 50 micrometers and 0.05 micrometers, more preferably between 25 micrometers and 1 micrometer.

25 Structured layers for any of the embodiments in accordance with the present invention can be formed from a variety of polymers or copolymers including thermoplastic, thermoset, and curable polymers. As used here, thermoplastic, as differentiated from thermoset, refers to a polymer which softens and melts when exposed to heat and re-solidifies when cooled and can be melted and solidified through many 30 cycles. A thermoset polymer, on the other hand, irreversibly solidifies when heated and cooled. A cured polymer system, in which polymer chains are interconnected or

crosslinked, can be formed at room temperature through use of chemical agents or ionizing irradiation.

Polymers useful in forming a structured layer in articles of the invention include but are not limited to polyolefins such as polyethylene and polyethylene copolymers, 5 polyvinylidene difluoride (PVDF), and polytetrafluoroethylene (PTFE). Other polymeric materials include acetates, cellulose ethers, polyvinyl alcohols, polysaccharides, polyolefins, polyesters, polyamids, poly(vinyl chloride), polyurethanes, polyureas, polycarbonates, and polystyrene. Structured layers can be cast from curable resin materials such as acrylates or epoxies and cured through free radical pathways promoted 10 chemically, by exposure to heat, UV, or electron beam radiation.

As indicated above, there are applications where flexible active fluid transport devices are desired. Flexibility may be imparted to a structured polymeric layer using polymers described in U.S. Patents 5,450,235 to Smith et al. and 5,691,846 to Benson, Jr. et al. The whole polymeric layer need not be made from a flexible polymeric material. A 15 main portion of the polymeric layer, for example, could comprise a flexible polymer, whereas the structured portion or portion thereof could comprise a more rigid polymer. The patents cited in this paragraph describe use of polymers in this fashion to produce flexible products that have microstructured surfaces.

Polymeric materials including polymer blends can be modified through melt 20 blending of plasticizing active agents such as surfactants or antimicrobial agents. Surface modification of the structured surfaces can be accomplished through vapor deposition or covalent grafting of functional moieties using ionizing radiation. Methods and techniques for graft-polymerization of monomers onto polypropylene, for example, by ionizing radiation are disclosed in US Patents 4,950,549 and 5,078,925. The polymers may also 25 contain additives that impart various properties into the polymeric structured layer. For example, plasticisers can be added to decrease elastic modulus to improve flexibility.

Preferred embodiments of the invention may use thin flexible polymer films that have parallel linear topographies as the microstructure-bearing element. For purposes of this invention, a "film" is considered to be a thin (less than 5 mm thick) generally flexible 30 sheet of polymeric material. The economic value in using inexpensive films with highly defined microstructure-bearing film surfaces is great. Flexible films can be used in

combination with a wide range of separation media and can be used unsupported or in conjunction with a supporting body where desired. The microstructured surfaces may be flexible for many applications but also may be associated with a rigid structural body where applications warrant.

5           Because the devices of the invention include microstructured channels, the devices commonly employ a multitude of channels per device. As shown in some of the embodiments illustrated above, inventive devices can easily possess more than 10 or 100 channels per device. Some applications, the device may have more than 1,000 or 10,000 channels per device. The more channels that are connected to an individual potential  
10 source allow the potential's effect to be more highly distributed.

To determine the efficacy of an active fluid transport separation device having a plurality of discrete flow passages defined by a layer having microchannels in a microstructured surface and a separation media cover layer, a separation device was constructed using a separation module formed from a microstructure-bearing film element,  
15 capped with a separation media. The microstructure-bearing film was formed by casting a molten polymer onto a microstructured nickel tool to form a continuous film with channels on one surface. The channels were formed in the continuous length of the cast film. The nickel casting tool was produced by shaping a smooth copper surface with diamond scoring tools to produce the desired structure followed by an electroless nickel plating step  
20 to form a nickel tool. The tool used to form the film produced a microstructured surface with abutted 'V' channels with a nominal depth of 459  $\mu\text{m}$  and an opening width of 420  $\mu\text{m}$ . This resulted in a channel, if closed, with a mean hydraulic radius of 62.5  $\mu\text{m}$ . The polymer used to form the film was low density polyethylene, Tenite™ 1550P from Eastman Chemical Company. A nonionic surfactant, Triton X-102 from Rohm & Haas  
25 Company, was melt blended into the base polymer to increase the surface energy of the film.

The separation media was a nonwoven blown microfiber web. The nonwoven web was produced from polypropylene, Fina 100 MFI, and had a solidity of 8% with fibers in the 2-5  $\mu\text{m}$  diameter size and a basis weight of 50  $\text{g}/\text{m}^2$ . Capping of the microreplicated  
30 film was accomplished by layering the film and nonwoven together with the microstructure of the film facing the nonwoven. After layering, the composite was sealed

on the two sides parallel to the linear microstructure. One end of the composite, where the microchannels terminated, was also heat sealed. The unsealed end was attached to the manifold that extended the width of the module.

The manifold was formed by placing a cut in the side wall of a section of tubing, VI grade 3.18 mm inner diameter, 1.6 mm wall thickness tubing form Nalge Co. of Rochester, New York. The slit was cut with a razor in a straight line along the axis of the tube. The length of the slit was approximately the width of the module. The tube was then fitted over the end of the module and hot met glued in place. One open end of the tube, at the module, was sealed closed with hot melt adhesive. The dimension of the module was 80 mm x 120 mm.

To evaluate the liquid/solid separation capability of the test module the unit was placed in a beaker with water and fine particle solids of AC test Dust, SAE coarse, commercially available from Powder Technology Inc. The test was conducted with the test unit placed in a 500 ml beaker, with the film side of the unit flat next to the inside wall of the beaker. A liquid recovery flask with a vacuum source was then attached to the test unit. After the vacuum was established, the beaker was filled to the top, submerging the test unit, with a suspension of AC test dust in water at a concentration of 15g/1000 ml. Liquid in the beaker was removed, through the separation module, to the recovery flask as the AC dust suspension was constantly stirred in the beaker. After the liquid was extracted through the microstructure-bearing film based separation apparatus, the recovered liquid was observed for the presence of suspended matter. No suspended matter was observed in the recovered liquid.

While a single microstructure-bearing film based separation module was used in the evaluation, multiple units could be used to increase separation capacity. A separation device of this kind, with the appropriate separation media, could be used in other separation applications such as air filtration. For very fine separations, a microporous film, for example, might be employed as the separation media. An alternate design might utilize a supplied fluid, passing first within a separation module, whereby the fluid flowing through the channels would exchange with the environment through the separation medium.

While the example unit was used to demonstrate a liquid / solid separation, other separations could also be accomplished with the use of similar constructions. Other separation mediums could be used as the application requires. Microporous membranes, for instance, would be particularly suited to application where gas / gas or ultrafine solid / liquid separations are required.

Throughout this specification and the claims which follow, unless the context requires otherwise, the word "comprise", and variations such as "comprises" or "comprising", will be understood to imply the inclusion of a stated integer or step or group of integers or steps but not the exclusion of any other integer or step or group of integers or steps.

The reference to any prior art in this specification is not, and should not be taken as, an acknowledgement or any form of suggestion that that prior art forms part of the common general knowledge in Australia.



The claims defining the present invention are as follows:

1. An active fluid transport separation device for removing a constituent of a fluid mixture, including:

(a) a first layer of polymeric film material having first and second major surfaces, wherein the first major surface is define by a structure polymeric surface formed within the layer, the structure polymeric surface having a plurality of flow channels that extend from a first point to a second point along the surface of the layer, the flow channels also having a minimum aspect ratio of about 10:1 and a hydraulic radius no greater than about 300 micrometers;

(b) a selectively permeable fluid separation media covering at least a plurality of the flow channels of the first layer, the separation media permitting fluid flow through the separation media but for removing a constituent component of the fluid mixture; and

(c) a source external to the structure polymeric surface, which source provides a potential over the flow channels to promote movement of fluid through the separation media and through the flow channels from a first potential to a second potential.

2. The active fluid transport separation device of claim 1, further including a manifold connected at a common side to each of the flow channels of the structured surface of the first layer for operatively permitting the source to provide a potential over the flow channels.

3. The active fluid transport separation device of claims 1 to 2, wherein the source includes a vacuum generator that is operatively connected to the manifold to drive fluid through the separation media and into the flow channels.

4. The active fluid transport separation device of claims 1 to 2, wherein the source includes a pressure source, and wherein the pressure source drives fluid through the separation media into the flow channels and out through the manifold, or wherein the pressure source drives fluid through the manifold into the flow channels and out through the separation media.



5. The active fluid transport separation device of claims 1 to 4, wherein the separation media includes selectively permeable separation material selected from the group comprising microporous film, nonwoven filtration web, and micro-perforated film.

6. The active fluid transport separation device of claims 1 to 5, wherein the plurality of flow channels are defined by a series of peaks, each peak having two sidewalls.

7. The active fluid transport separation device of claims 1 to 6, wherein the sidewalls of adjacent peaks of the flow channels are separated by a planar floor or wherein the sidewalls of adjacent peaks of the flow channels are separated by at least one sub-peak, the sub-peak defining a plurality of sub-channels within each flow channel.

8. The active fluid transport separation device of claims 1 to 7, further including:  
at least one additional layer of polymeric film material having first and second major surfaces, wherein the first major surface is defined by a structured polymeric surface formed within the layer, the structured polymeric surface having a plurality of substantially flow channels that extend from a first point to a second point along the surface of the layer, the flow channels also having a minimum aspect ratio of about 10:1 and a hydraulic radius no greater than about 300 micrometers;

a selectively permeable fluid separation media covering at least a plurality of the flow channels of the at least one additional layer, the separation media permitting fluid flow through the separation media but for removing a constituent component of the fluid mixture;

wherein the external source provides a potential over the flow channels of both the first layer and the at least one additional layer to promote movement of fluid through the separation media and through the flow channels from a first potential to a second potential.



9. A method of removing a constituent of a fluid mixture including the steps of:

(a) providing a separation module having a first layer of polymeric film material having first and second major surfaces, wherein the first major surface is defined by a structured polymeric surface formed within the layer, the structured polymeric surface having a plurality of flow channels that extend from a first point to a second point along the surface of the layer, the flow channels also having a minimum aspect ratio of about 10:1 and a hydraulic radius no greater than about 300 micrometers; and a selectively permeable fluid separation media covering at least a plurality of the flow channels;

(b) connecting the separation module to a source provided external to the structured polymeric surface, for providing a potential over the flow channels to promote movement of fluid through the flow channels from a first potential to a second potential;

(c) at least partially immersing the separation module into the fluid mixture;

(d) driving the fluid mixture through the separation module by the source, and thereby removing a constituent component of the fluid mixture by the separation media while permitting fluid flow therethrough.

10. The method of claim 9, wherein the externally provided source is a vacuum generator.

11. An active fluid transport separation device for removing a constituent of a fluid mixture, substantially as herein described with reference to the accompanying drawings.

12. A method of removing a constituent of a fluid mixture, substantially as herein described.

25

DATED this 8th day of November, 2001

3M INNOVATIVE PROPERTIES COMPANY

By Their Patent Attorneys

30 DAVIES COLLISON CAVE



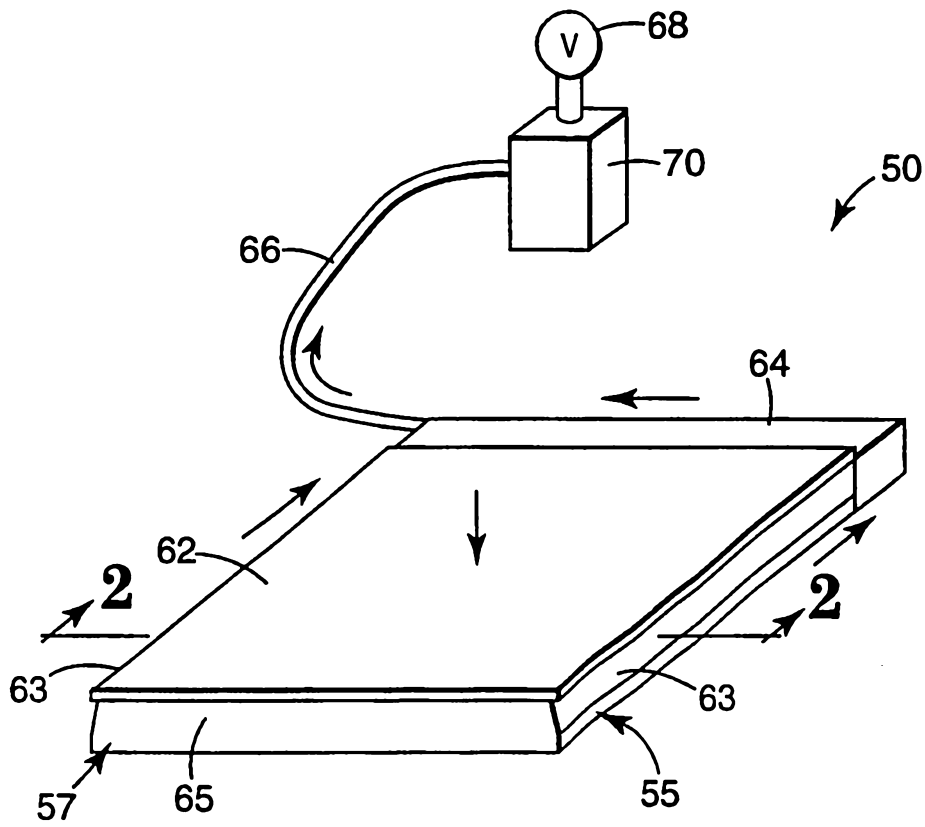
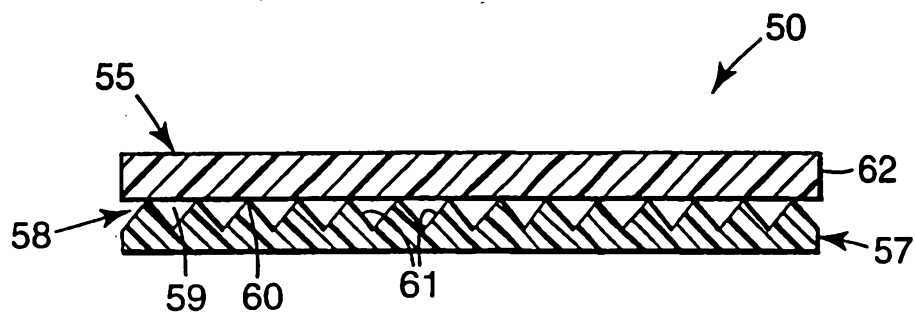
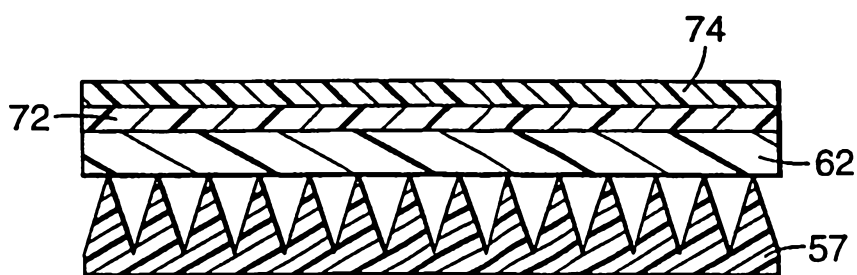


Fig. 1



**Fig. 2**



**Fig. 4**

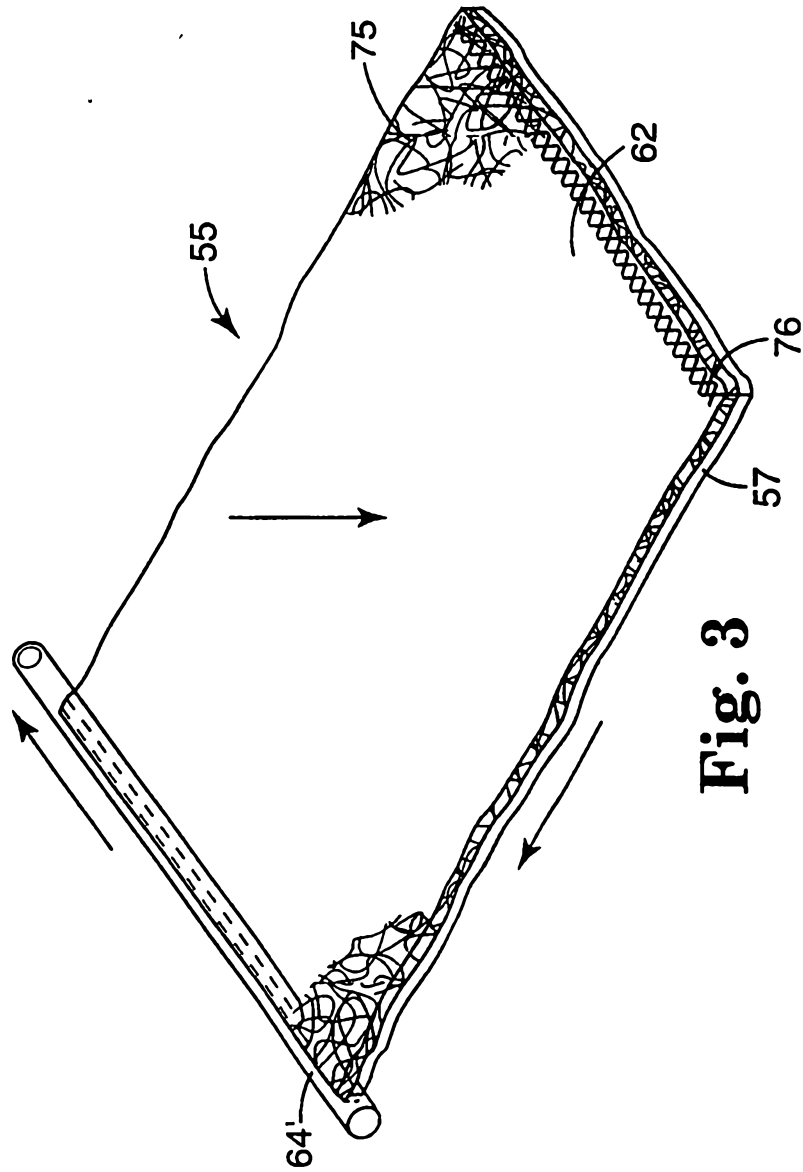
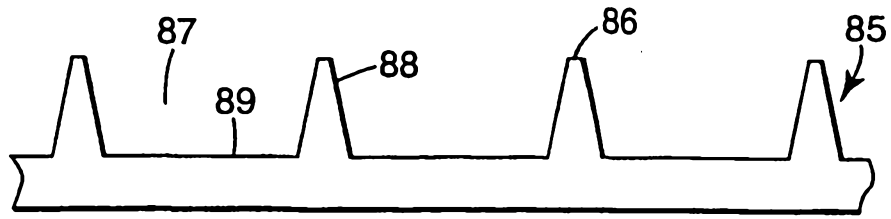
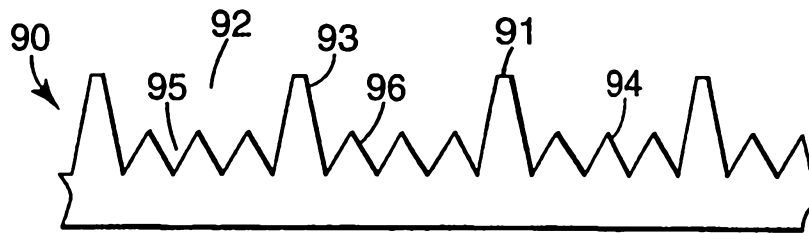


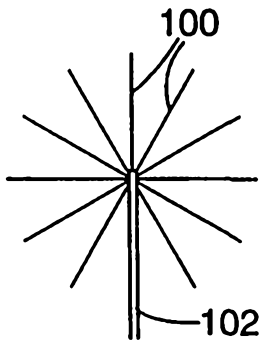
Fig. 3



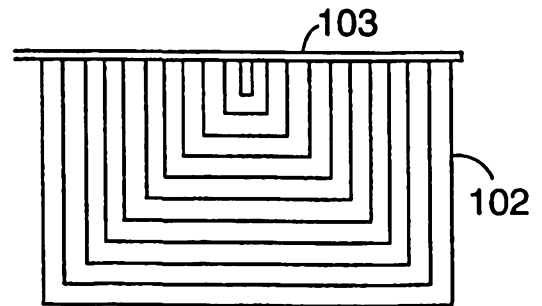
**Fig. 5**



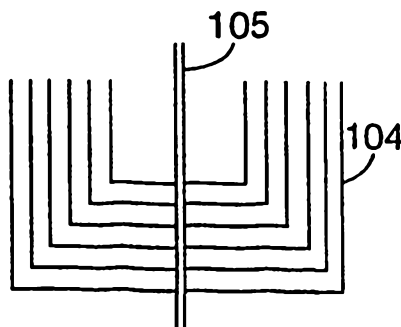
**Fig. 6**



**Fig. 7**

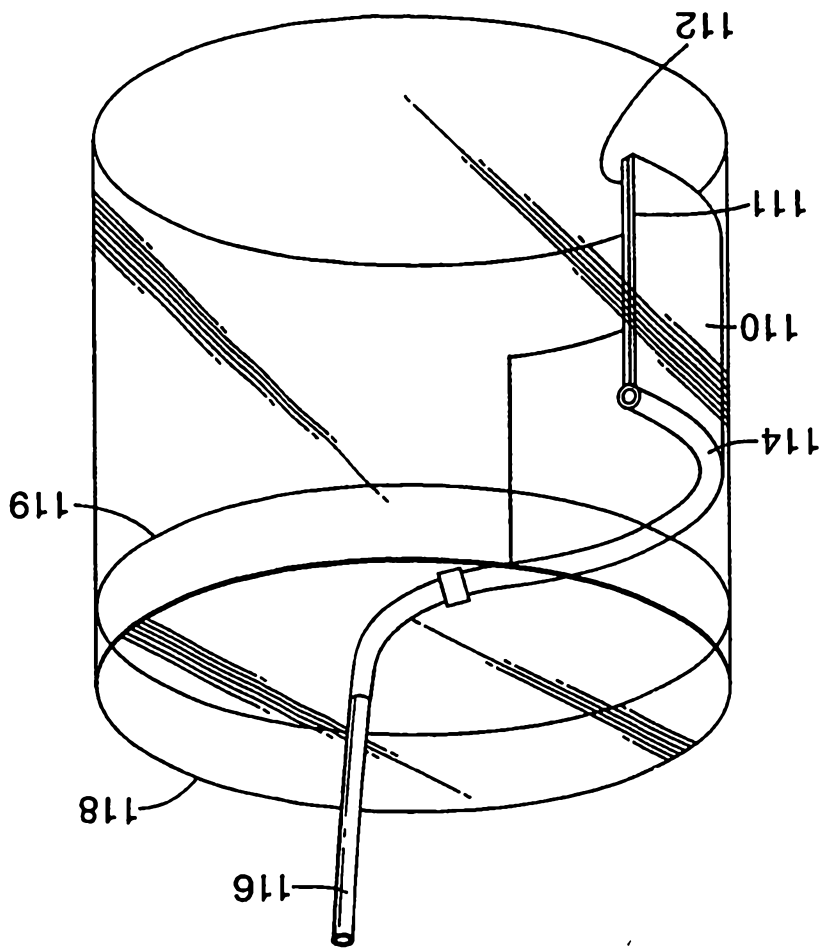


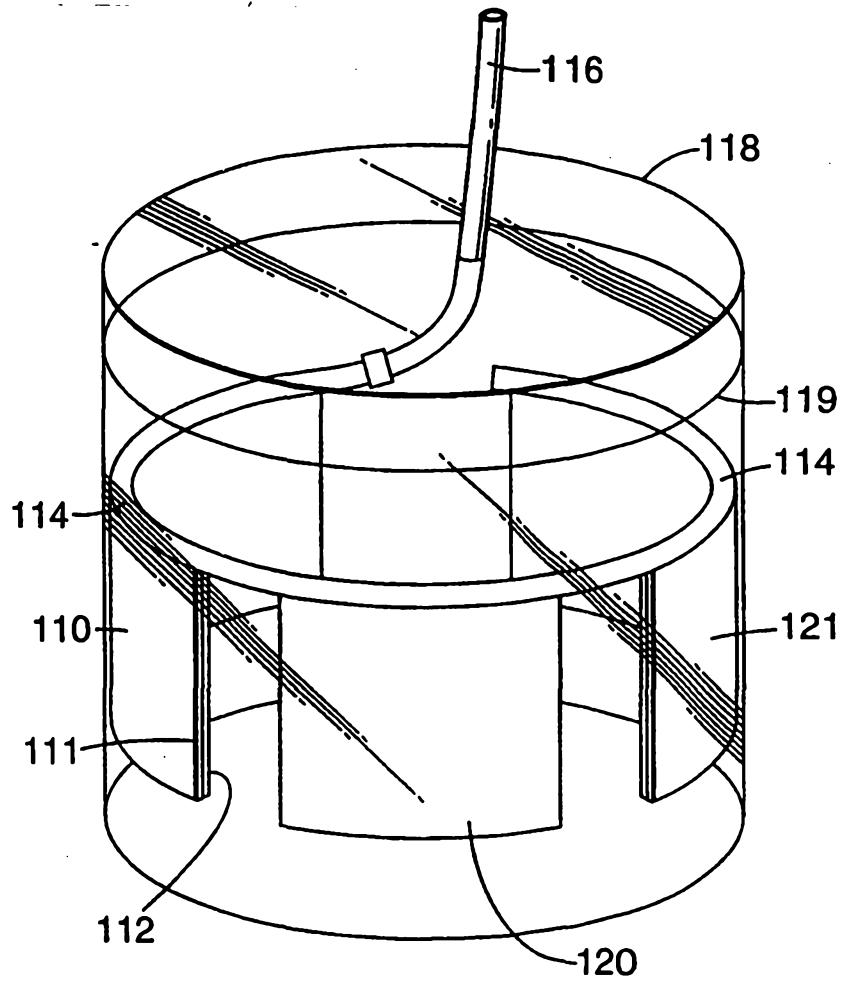
**Fig. 8**



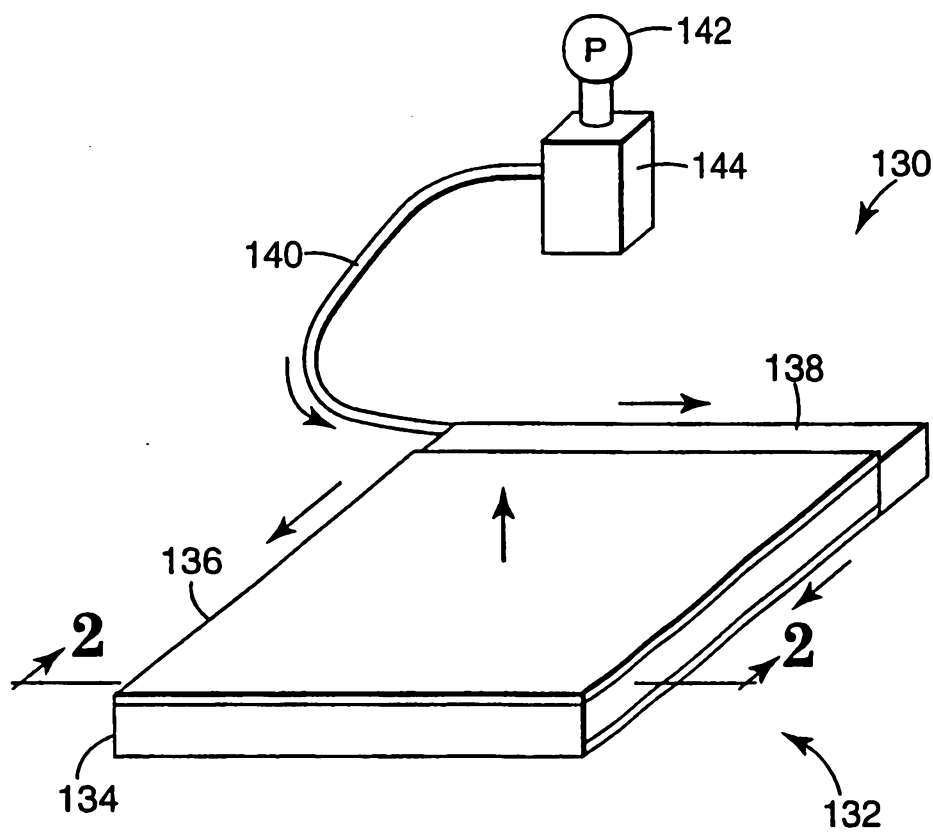
**Fig. 9**

Fig. 10

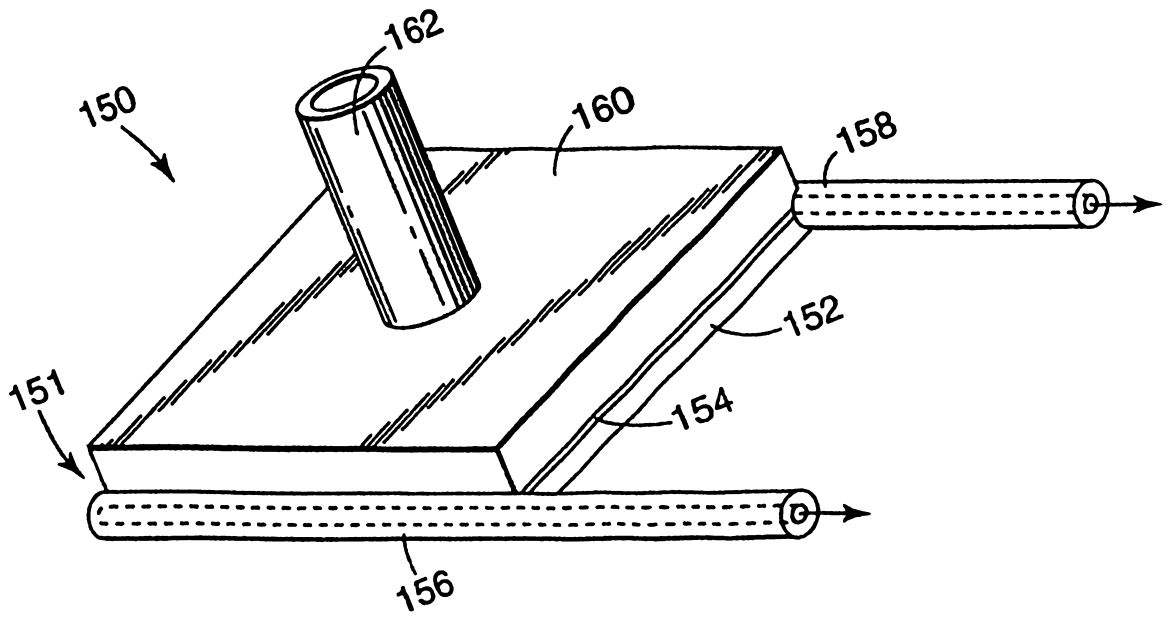




**Fig. 11**



**Fig. 12**



**Fig. 13**