

March 19, 1935.

P. DIETERLE

1,994,854

PASTE STRIP MACHINE

Filed Sept. 18, 1933

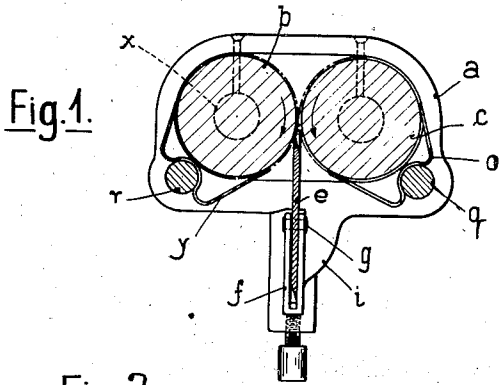

Fig. 2.

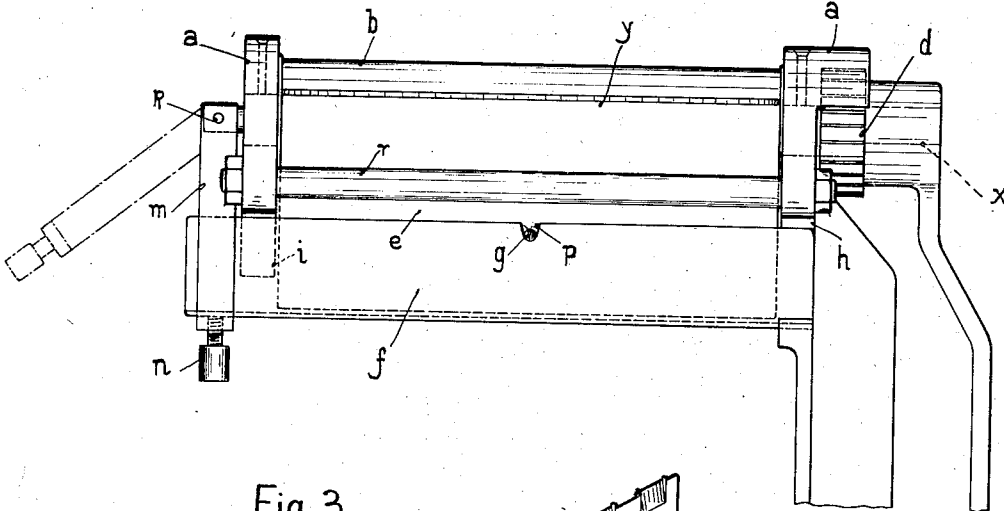
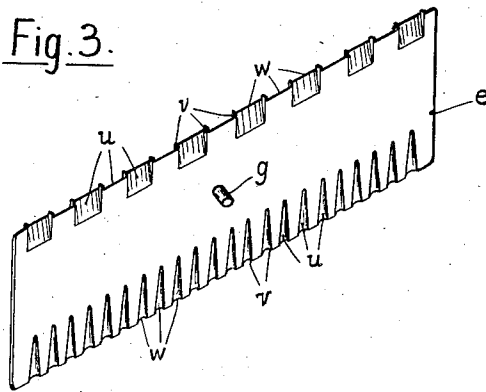

Fig. 3.



Inventor:  
Philipp Dieterle  
By *[Signature]*  
Attorney

# UNITED STATES PATENT OFFICE

1,994,854

## PASTE STRIP MACHINE

Philipp Dieterle, Winzeln O. A. Oberndorf, Germany, assignor to Eisenfuchs G. m. b. H., Stuttgart, Germany

Application September 18, 1933, Serial No. 689,951  
In Germany June 2, 1933

1 Claim. (Cl. 107—20)

This invention relates to paste strip machines with two smooth cylinders and a stripper extending into the gap between the cylinders and provided on its front edge with knives for dividing the paste band into separate longitudinal strips.

In the known paste strip machines of this type the paste strips are led off close together on one side of the stripper plate so that, especially when producing narrow paste strips, there is a danger of the strips sticking together immediately after being separated.

In paste strip machines with a smooth cylinder and a knife cylinder cooperating therewith and in the gaps of which resilient strippers engage, it has been possible by the displaced arrangement of the juxtaposed strippers to deflect the neighboring strips of paste in different directions when they are leaving the machine and to thus prevent them from sticking together. This type of paste strip machine is, however, open to the objection that the width of the paste strips is determined by the spacing of the cylinder knives and a changing of the paste strip width would necessitate exchanging of the knife cylinder.

A leading apart of the neighboring paste strips is rendered possible in the paste machines mentioned at the outset in that the cutting edges of the stripper extend in a zig-zag line composed of edge sections arranged alternately on the one and other cylinder parallel with the axes thereof and having intermediate short connecting edges acting as longitudinal severing knives.

An embodiment of the invention is illustrated by way of example in the accompanying drawing in which:—

Fig. 1 is a cross section through the machine.

Fig. 2 shows the machine in side elevation.

Fig. 3 is a perspective view of the stripper acting as cutting device.

Two horizontal cylinders *b* and *c* are journaled side by side in known manner in two side frames *a*, one of which (that shown on the right in Fig. 2) is extended in downward direction and forms a known clamping device (not shown in the drawing) for fixing the machine on a table or the like. The two cylinders are positively connected by toothed wheels *d*, and a hand crank is mounted on the end of the axle *x* of one of the cylinders. A stripper *e* arranged on the discharge side of the cylinder and forming a dividing device is oscillatably mounted in known manner by means of a pin *g* in a recess *p* of a U-shaped holder *f* (Figs. 1 and 2) so that it can bear against the cylinders independently of the position of the holder. The holder *f* is loosely suspended with inserted stripper *e* in a recess *h* in the side frame *a* (on the right of Fig. 2) and pressed against a flap *i* of the opposite side frame, so that a strap *m* oscillatably

mounted at *r* can grip from below over the same and press it upwards with the aid of a pressure screw *n* on this strap. The upper longitudinal edges of the stripper *e* extend into the gap between the cylinders *b* and *c* until they bear against these cylinders (Fig. 1).

According to the invention the milled or stamped out portions *u* forming the cutting edge of the stripper *e* are arranged alternately on the two sides, so that a cutting edge extending in a zig-zag line is formed which is composed of edge sections *w* bearing alternately against the two cylinders and having intervening connecting edges *v* acting as longitudinal dividing knives. The spacing of the milled or stamped out portions *u* is, in known manner, different on the two longitudinal edges of the stripper to enable two different widths of paste strips to be produced with one stripper.

Strippers *o* and *y* are also provided, which merely serve for cleaning the cylinders, and, as shown in Fig. 1, are bent from resilient sheet metal strips and held by anchor bars *q* and *r* uniting the two side frames *a*.

The machine operates in the following manner:—

The paste in the form of a flat cake is fed downwards with one hand between the cylinders *b* and *c* which are rotated in the direction of the arrows Fig. 1 by turning the crank on the axle *x* with the other hand. The paste is drawn between these cylinders and rolled into a thin cake which, immediately upon being produced, is divided into narrow strips by the edges *v* of the stripper *e*. Owing to the zig-zag shape of the cutting edge of the stripper, strips are delivered towards the two sides of the machine, the distance between the individual strips of paste delivered on each side of the machine corresponds to the actual width of the paste strips. The finished paste strips descend on to the table or drop in a receptacle placed thereon ready to receive them. The residues of paste scraped off the cylinders by the strippers *o*, *y*, as they represent only small quantities, can be allowed to remain with the paste strips. When the paste strips have dried sufficiently they can be used in soups or the like.

I claim:—

A paste strip machine, comprising in combination two smooth cylinders, a stripper extending into the gap between said cylinders, and a cutting edge on said stripper extending in a zig-zag line and composed of edge sections bearing alternately against said two cylinders and parallel to the axes thereof, and of short connecting edges between said sections adapted to act as longitudinal dividing knives.

PHILIPP DIETERLE.