

(19) World Intellectual Property Organization
International Bureau



(43) International Publication Date
11 December 2008 (11.12.2008)

PCT

(10) International Publication Number
WO 2008/149111 A1

- (51) International Patent Classification:
B01L 3/00 (2006.01)
- (21) International Application Number:
PCT/GB2008/001956
- (22) International Filing Date: 9 June 2008 (09.06.2008)
- (25) Filing Language: English
- (26) Publication Language: English
- (30) Priority Data:
0710957.2 7 June 2007 (07.06.2007) GB
- (71) Applicant (for all designated States except US):
NORCHIP A/S [NO/NO]; Industriveien 8, N-3490
Klokkarstua (NO).
- (71) Applicant (for MG only): SETNA, Rohan, Pilo
[GB/GB]; Verulam Gardens, 70 Grays Inn Road, London
WC1X 8BT (GB).
- (72) Inventors; and
- (75) Inventors/Applicants (for US only): SOLLI, Lars,
A. [NO/NO]; NORCHIP, Industriveien 8, N-3490
Klokkarstua (NO). GULLIKSEN, Anja [NO/NO];
NORCHIP, Industriveien 8, N-3490 Klokkarstua (NO).
KARLSEN, Frank [NO/NO]; NORCHIP, Industriveien
8, N-3490 Klokkarstua (NO). BAIER, Tobias; Institut
fur Mikrotechnik Mainz GmbH, Carl-Zeiss-Strasse 18-20,

- 55129 Mainz (DE). GRANSEE, Rainer; Institut fur
Mikrotechnik Mainz GmbH, Carl-Zeiss-Strasse 18-20,
55129 Mainz (DE). HANSEN-HAGGE, Thomas; Institut
fur Mikrotechnik Mainz GmbH, Carl-Zeiss-Strasse 18-20,
55129 Mainz (DE). DRESE, Klaus, Stefan; Institut fur
Mikrotechnik Mainz GmbH, Carl-Zeiss-Strasse 18-20,
55129 Mainz (DE). FURUBERG, Liv; SINTEF ICT, Pb.
124 Blindern, N-0314 Oslo (NO).
- (74) Agents: WHITE, Nina, Louise et al.; Boulton
Tennant, Verulam Gardens, 70 Gray's Inn Road, London
WC1X 8BT (GB).
- (81) Designated States (unless otherwise indicated, for every
kind of national protection available): AE, AG, AL, AM,
AO, AT, AU, AZ, BA, BB, BG, BH, BR, BW, BY, BZ, CA,
CH, CN, CO, CR, CU, CZ, DE, DK, DM, DO, DZ, EC, EE,
EG, ES, FI, GB, GD, GE, GH, GM, GT, HN, HR, HU, ID,
IL, IN, IS, JP, KE, KG, KM, KN, KP, KR, KZ, LA, LC,
LK, LR, LS, LT, LU, LY, MA, MD, ME, MG, MK, MN,
MW, MX, MY, MZ, NA, NG, NI, NO, NZ, OM, PG, PH,
PL, PT, RO, RS, RU, SC, SD, SE, SG, SK, SL, SM, SV,
SY, TJ, TM, TN, TR, TT, TZ, UA, UG, US, UZ, VC, VN,
ZA, ZM, ZW.
- (84) Designated States (unless otherwise indicated, for every
kind of regional protection available): ARIPO (BW, GH,

[Continued on next page]

(54) Title: A DEVICE FOR CARRYING OUT CELL LYSIS AND NUCLEIC ACID EXTRACTION

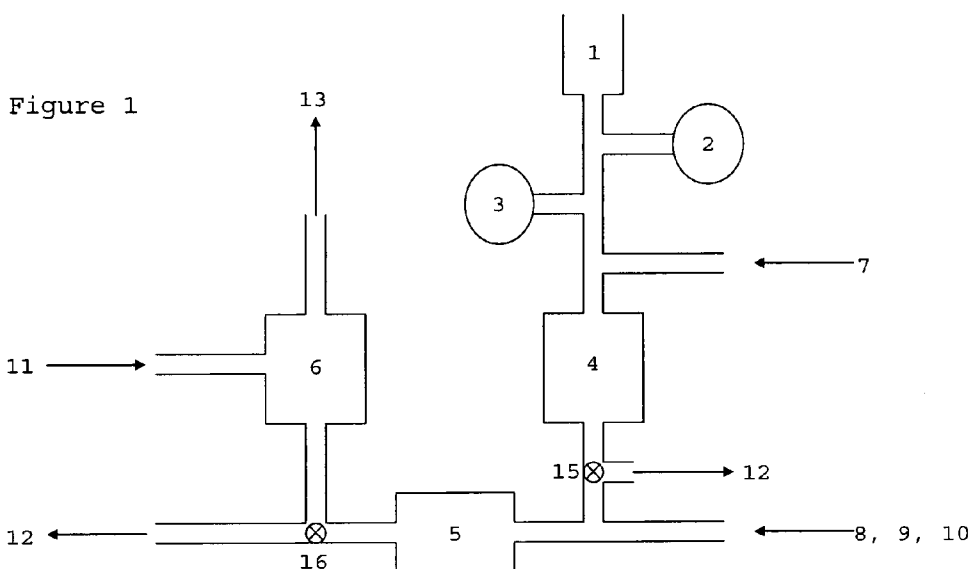

(57) Abstract: The present invention provides an integrated lab-on-a-chip device for carrying out a nucleic acid extraction process on a fluid sample containing cells and/or particles, the device comprising: (a) a sample inlet (1) for loading of a fluid sample, (b) a lysis unit (4) for lysis of cells and/or particles present in the fluid sample, (c) a reservoir of lysis fluid (7) for the lysis unit, (d) a nucleic acid extraction unit (5) downstream of the lysis unit, and (e) reservoirs of first washing buffer and eluant fluid (8, 9, 10) for the nucleic acid extraction unit, wherein the device further comprises (f) a mixing unit (6) downstream of the nucleic acid extraction unit, and (g) a source of mixing fluid (11) for the mixing unit. The reservoirs of lysis fluid, first washing buffer and eluant fluid may be provided parallel to one another so that they may be actuated by a single pump.

WO 2008/149111 A1



GM, KE, LS, MW, MZ, NA, SD, SL, SZ, TZ, UG, ZM, ZW), Eurasian (AM, AZ, BY, KG, KZ, MD, RU, TJ, TM), European (AT, BE, BG, CH, CY, CZ, DE, DK, EE, ES, FI, FR, GB, GR, HR, HU, IE, IS, IT, LT, LU, LV, MC, MT, NL, NO, PL, PT, RO, SE, SI, SK, TR), OAPI (BF, BJ, CF, CG, CI, CM, GA, GN, GQ, GW, ML, MR, NE, SN, TD, TG).

Published:

— *with international search report*

- 1 -

A device for carrying out cell lysis and nucleic acid
extraction

The present invention relates to an integrated lab-on-a-chip
5 diagnostic device for carrying out combined cell lysis and
nucleic acid (NA) extraction. The system may be used to
extract nucleic acid from a test sample containing cells
and/or particles.

10 Background to the invention

The analysis of DNA and/or RNA from bacterial cells and
virus particles is a key step in many areas of technology
such as, for example, diagnostics, environmental monitoring,
15 forensics and molecular biology research. In order to
analyze samples containing nucleic acids, it is usually
necessary to carry out two procedures. Firstly, the sample
is broken down, isolated and concentrated to produce a
purified nucleic acid extract. Secondly, the purified
20 nucleic acid extract is amplified in order increase the
amount of nucleic acid present to facilitate detection of
the nucleic acid.

Conventionally, extraction, purification and amplification
25 of the nucleic acid is carried out manually in a laboratory
by a trained technician. This not only requires the
presence of a skilled user, it also leads to a significant
error rate due to user errors. In addition, this
conventional extraction requires the extraction,
30 purification and amplification to take place away from the
point-of-care and, as a result, the result of the biological
assay is delayed. Therefore, there is a need for providing

- 2 -

a biological assay that reduces and simplifies user input and allows the assay to be carried out when and where the sample is actually taken, for example within the doctor's surgery, the clinic, the veterinary surgery or even in the
5 patient's home or in the field.

Microfabricated "lab-on-a-chip" devices are an attractive option for carrying out contained biological reactions. These devices require minimal reagent handling by the user
10 and also permit the use of small sample volumes, a significant advantage for biological reactions which require expensive reagents.

One previous approach to providing a microfabricated "lab-
15 on-a-chip" device to extract and purify a sample comprising a nucleic acid is described in WO 2005/073691. In this document, a sample containing cells and / or particles is filtered. The filtrate (i.e. the cells and / or particles) is subject to lysis by a lysis fluid. Then, the lysed
20 sample is passed through a nucleic acid extraction unit. The nucleic acids are extracted and remain in the extraction unit whereas the lysis fluid passes through the unit. An example of a suitable nucleic acid extraction method involves the binding of DNA to silica particles in the
25 presence of a chaotropic agent (see Boom et al, J. Clin. Microbiol. 1990, 28, 495-503). The extracted nucleic acids are washed with one or more washing solvents, followed by extraction of the nucleic acids with an eluant. This step also serves to concentrate the nucleic acid.

30

WO 2005/073691 describes how a single pump may be used to actuate all fluids within its system once the sample has

- 3 -

been syringed into the system. WO 2005/073691 then describes one way of achieving this, namely to provide the lysis fluid, washing fluids and eluant in a single channel separated by air gaps.

5

Once the nucleic acid has been extracted, concentrated and purified, it is then usually necessary to amplify it. While conventionally the Polymerase Chain Reaction (PCR) technique is used, a different amplification technique that may be used in some circumstances is Nucleic Acid Sequence Based Amplification (NASBA). As will be appreciated by the person skilled in the art, NASBA is different from PCR in several ways. In particular, PCR involves thermal cycling of a sample that generally produces only DNA amplification products while NASBA is an isothermal technique that is generally used to produce RNA amplification products.

10
15

A microfabricated system that is especially designed for carrying out NASBA is described in WO 02/22265. This system comprises two chambers. The first chamber heats the sample up, denatures it and facilitates the binding of primers to the denatured sample. The second chamber contains the NASBA enzymes and heats the sample isothermally to a temperature of about 41°C.

20
25

In order to carry out amplification, it is necessary to mix the nucleic acid sample with primers. These primers require the presence of a mixing fluid. This fluid may comprise one or both of DMSO and sorbitol. In WO 02/22265, it is described how this fluid is pre-loaded into the first reaction chamber and the mixing of the sample with the fluid occurs within the first reaction chamber.

30

Summary of the invention

The present invention provides an improved integrated device
5 for carrying out both cell lysis and nucleic acid
(preferably mRNA) extraction, which device is pre-loaded
with reagents required for cell lysis and nucleic acid
extraction. The device of the invention is characterised in
that the various pre-loaded reagents are loaded in a manner
10 that can be precisely controlled and can be actuated by a
single pump. In particular, the use of variable-position
valves in combination with a parallel set of fluid
reservoirs to contain the pre-loaded reagents allows the
fluids to be precisely and reliably actuated by a single
15 pump. Additionally or alternatively, the device is
characterized in that the device comprises a means for
mixing the sample with a solvent after the nucleic acid
sample has been extracted and purified, prior to the sample
being transferred to a nucleic acid amplification unit.

20

Accordingly, the present invention provides an integrated
lab-on-a-chip device for carrying out a nucleic acid
extraction process on a fluid sample containing cells and/or
particles, the device comprising:

- 25 (a) a sample inlet for loading of a fluid sample,
(b) a lysis unit for lysis of cells and/or particles
present in the fluid sample,
(c) a reservoir of lysis fluid for the lysis unit,
(d) a nucleic acid extraction unit downstream of the
30 lysis unit, and
(e) reservoirs of first washing buffer and eluant
fluid for the nucleic acid extraction unit,

the device further comprising:

(f) a mixing unit downstream of the nucleic acid extraction unit, and

(g) a source of mixing fluid for the mixing unit.

5

In a second aspect, the invention provides an integrated lab-on-a-chip device for carrying out a nucleic acid extraction process on a fluid sample containing cells and/or particles, the device comprising:

- 10 (a) a sample inlet for loading of a fluid sample,
(b) a lysis unit for lysis of cells and/or particles present in the fluid sample,
(c) a reservoir of lysis fluid for the lysis unit,
(d) a nucleic acid extraction unit downstream of the

15 lysis unit, and

(e) reservoirs of first washing buffer and eluant fluid for the nucleic acid extraction unit,

wherein the reservoirs of lysis fluid, first washing buffer and eluant fluid are arranged in parallel, each reservoir having an upper end and a lower end, wherein the
20 device further comprises:

(h) an upper variable-position valve connected to the upper ends of the reservoirs of lysis fluid, first washing buffer and eluant fluid,

25 (i) a pump connected to the upper variable-position valve,

(j) a lower variable-position valve connected to the lower ends of the at least three fluid reservoirs,

(k) a first actuation channel connecting the lower
30 variable-position valve to the lysis unit, and

- 6 -

(1) a second actuation channel connecting the lower variable-position valve to the nucleic acid extraction unit.

The features of this second aspect may be used separately
5 from the first aspect or may be combined with the features of the first aspect.

In a third aspect, the invention provides an integrated lab-on-a-chip diagnostic system for carrying out nucleic acid
10 extraction and a nucleic acid sequence amplification and detection process on a fluid sample containing cells and/or particles, the system comprising a nucleic acid extraction device according to the first or second aspects of the invention and a nucleic acid amplification unit.

15

In a fourth aspect, the invention provides a method of carrying out a nucleic acid extraction process on a fluid sample containing cells and/or particles using an integrated lab-on-a-chip device, the method comprising:

20 (i) providing an integrated lab-on-chip device comprising a sample inlet, a lysis unit, a nucleic acid extraction unit, a mixing unit, and reservoir of lysis fluid, first washing buffer, eluant fluid and mixing fluid,

25 (ii) loading a sample through the sample inlet of the device,

(iii) carrying out lysis on the cells and / or particles of the sample by passing lysis fluid from the lysis fluid reservoir over the cells and / or
30 particles,

(iv) passing the lysis fluid through the nucleic acid extraction unit to extract nucleic acids,

- 7 -

- (v) transferring first washing buffer from the first washing buffer reservoir through the nucleic acid extraction unit,
- (vi) transferring eluant fluid from the eluant reservoir through the nucleic acid extraction unit to produce an eluted sample from the nucleic acid extraction unit, and
- (vii) mixing the eluted sample with mixing fluid in the mixing unit.
- 10 The device of the first or second aspects or the system of the third aspect may be used in this method.

In a fifth aspect, the present invention provides a method of carrying out a nucleic acid extraction process on a fluid sample containing cells and/or particles using an integrated lab-on-a-chip device, the method comprising:

- (i) providing an integrated lab-on-chip device comprising a sample inlet, a lysis unit, a nucleic acid extraction unit, and reservoir of lysis fluid, first washing buffer and eluant fluid,
- (ii) loading a sample through the sample inlet of the device,
- (iii) carrying out lysis on the cells and / or particles filtered of the sample by passing lysis fluid from the lysis fluid reservoir over the cells and / or particles,
- (iv) passing the lysis fluid through the nucleic acid extraction unit to extract nucleic acids,
- (v) transferring first washing buffer from the first washing buffer reservoir through the nucleic acid extraction unit, and

- 8 -

(vi) transferring eluant fluid from the eluant reservoir through the nucleic acid extraction unit to produce an eluted sample from the nucleic acid extraction unit,

5 wherein the lysis fluid, first washing buffer and eluant fluid are actuated by a single pump.

The features of this fifth aspect may be used separately from the fourth aspect or may be combined with the features of the fourth aspect. The device of the first or second
10 aspects or the system of the third aspect may be used in this method.

Brief description of the drawings

15 The invention is described in relation to the following drawings. These drawings are provided as examples of the invention.

Figures 1 and 2 provide schematic illustrations of devices
20 according to the invention.

Figure 3 shows a parallel arrangement of reagent storage reservoirs.

25 Figures 4 and 5 show examples of configurations of the mixing unit.

Figure 6 is a step-by-step guide of examples of processes that may be undertaken in the device of the present
30 invention.

Figure 7 is an exemplary nucleic acid amplification system.

Figure 8 shows a detailed example of the present invention.

Figure 9 shows a detailed example of a mixing unit of the
5 present invention.

Detailed description of the invention

The present invention provides an integrated lab-on-a-chip
10 device for carrying out a complete sample preparation
process. The device may be used in or in conjunction with,
or integrally formed with, a microfabricated reaction
chamber system for carrying out nucleic acid amplification
and detection.

15

The inventors of the present invention have recognised the
advantage of using the system described in WO 2005/073691
for preparing a nucleic acid sample before it is amplified.
The inventors have also noted that WO 02/22265 provides a
20 convenient microfabricated system for carrying out a nucleic
acid amplification reaction, in particular NASBA. However,
when trying to combine a sample preparation system such as
that described in WO 2005/073691 and an amplification system
such as that described in WO 02/22265, the present inventors
25 found that sometimes the combined system showed reduced
specificity and effectiveness compared to what was expected
from macro-scale experiments.

The inventors found that this reduced specificity
30 surprisingly resulted from the primers in the amplification
reaction itself. In particular, WO 02/22265 suggests pre-
loading all reagents for its amplification reaction into its

microfabricated system prior to loading of its sample. While the inventors recognised that this approach is advantageous because it simplifies the manufacture and operation of the amplification system, the inventors found
5 that the pre-loading of one reagent in particular can reduce the specificity of the amplification reaction. This particular reagent is the mixing fluid used in amplification to solvate the primers and mix them with the sample.

10 Without wishing to be bound by theory, it is thought that the mixing solvent helps to solvate primer molecules used in amplification so that the primer molecules are fully extended. If a mixing solvent is not used, the primer molecules are not fully extended and therefore the
15 specificity of their binding is though to be reduced. The inventors have found this to be a particular issue in NASBA, where a DMSO / sorbitol mixture may be used to solvate the NASBA primers.

20 Therefore, the inventors looked for other ways to provide the mixing fluid. The inventors found that, by mixing the mixing fluid with the nucleic acid sample after the nucleic acid extraction and purification but before the sample is transferred to the nucleic acid amplification unit, the
25 specificity of the binding of the primers to the sample could be increased.

Accordingly, in a first aspect, the present invention provides an integrated lab-on-a-chip device for carrying out
30 a nucleic acid extraction process on a fluid sample containing cells and/or particles, the device comprising:

- (a) a sample inlet for loading of a fluid sample,

- 11 -

- (b) an optional filtration unit downstream of the sample inlet,
- (c) a lysis unit for lysis of cells and/or particles present in the fluid sample, either integrated with the filtration unit if present or downstream of the filtration unit,
- (d) a reservoir of lysis fluid for the lysis unit,
- (e) a nucleic acid extraction unit downstream of the lysis unit, and
- (f) reservoirs of first washing buffer and eluant fluid for the nucleic acid extraction unit,
- the device further comprising:
- (g) a mixing unit downstream of the nucleic acid extraction unit, and
- (h) a source of mixing fluid for the mixing unit.

The inventors have also recognised the advantage of using a single pump to actuate the pre-loaded reagents in the device of WO 2005/073691. In particular, the use of a single pump provides a simplified microfabricated assay. WO 2005/073691 suggests one way to design its system so it can use a single pump is to separate the lysis fluid, washing fluids and eluant in a single channel with air gaps. However, the inventors of the present invention have found that, when using this approach, the different fluids have a tendency to coalesce. This is especially a problem when using low surface energy solvents, such as alcohols (including ethanol and *iso*-propanol), which are typically used as washing solvents.

30

Therefore, in a second aspect, the present invention provides an integrated lab-on-a-chip device for carrying out

- 12 -

a nucleic acid extraction process on a fluid sample containing cells and/or particles having a specific reagent storage unit for pre-loading and controlling the movement of its reagents. This device comprises:

- 5 (a) a sample inlet for loading of a fluid sample,
 (b) an optional filtration unit downstream of the sample inlet,
 (c) a lysis unit for lysis of cells and/or particles present in the fluid sample, either integrated with the
10 filtration unit if present or downstream of the filtration unit,
 (d) a reservoir of lysis fluid for the lysis unit,
 (e) a nucleic acid extraction unit downstream of the lysis unit, and
15 (f) reservoirs of first washing buffer and eluant fluid for the nucleic acid extraction unit,
 wherein the reservoirs of lysis fluid, first washing buffer and eluant fluid are arranged in parallel, each reservoir having an upper end and a lower end, wherein the
20 device further comprises:
 (i) an upper variable-position valve connected to the upper ends of the reservoirs of lysis fluid, first washing buffer and eluant fluid,
 (g) a pump connected to the upper variable-position
25 valve,
 (h) a lower variable-position valve connected to the lower ends of the at least three fluid reservoirs,
 (j) a first actuation channel connecting the lower variable-position valve to the lysis unit, and
30 (k) a second actuation channel connecting the lower variable-position valve to the nucleic acid extraction unit.

The features of the second aspect may be used in the first aspect and vice versa.

5 As used herein, the term "*downstream*" means that, in use, a sample passes sequentially through the different parts of the device. While the term "*downstream*" includes within its scope two parts of the device being in direct fluid communication, it also includes within its scope when the
10 two parts are separated by, for example, a valve or another part of the device. The term "*integrated*" means that two different parts of the device are combined into a single unit, so that, for example, the same part of the device can serve to filter the sample and act as a lysis unit. When
15 the term "*integrated*" is applied to the device of the first and second aspects of the present invention combined with a nucleic acid amplification unit, it means that the two parts of the system are connected to one another so that, in use, they are in fluid communication with one another. In
20 another aspect, the term "*integrated*" means that the different parts of the device are preferably formed on a common substrate. The term "*connected*" when applied to two parts of the device means that the two parts may be in direct fluid communication with one another (e.g. through
25 either being joined directly together or joined through a channel) or may be separated from one another by, for example, a valve or another part of a device. Preferably, the term "*connected to*" means that two parts of the device are directly joined to one another.

30

The features of the first and second aspects will now be described in greater detail below.

The sample inlet

The sample inlet is designed to allow a sample to be loaded into the device. It may be suitable, for example, for
5 injection of a sample through a syringe. The sample inlet may also be connected to a pump. In this case, the sample may be contained in a container without its own means of actuation, so that, in use, the sample is sucked into the sample inlet port by the pump.

10

The filtration unit

The device may comprise a filtration unit. This unit may either be upstream of or integrally formed with the lysis unit. The filtration unit may comprise, for example, a
15 cross-flow filter or a hollow filter. Alternatively, the lysis unit may itself further comprise means to filter the fluid sample. Said means may comprise, for example, a cross-flow filter or a hollow filter, which may be integrated with the lysis unit.

20

The lysis unit and an optional nucleic acid fragmentation unit

The device includes a lysis unit suitable for lysing cells present in a fluid sample (e.g. a biological or
25 environmental fluid or a fluid sample derived therefrom) and a nucleic acid extraction unit, suitable for extracting nucleic acid (e.g. mRNA) from the contents of cells or particles lysed in the lysis unit. The lysis unit may be any lysis unit, such as that described in WO 2005/073691,
30 the contents of which are incorporated herein in their entirety by reference. The lysis unit may have any suitable shape and configuration but will typically be in the form of

- 15 -

a channel or chamber. The lysis unit is preferably for lysis of eukaryotic and/or prokaryotic cells and particles, e.g. virus particles, contained in the fluid sample.

5 If desired, the device may further comprise a nucleic acid fragmentation unit, which is downstream of the lysis unit and preferably upstream of the nucleic acid extraction unit. Alternatively, the lysis unit may itself further comprise means to fragment nucleic acid released when cells/particles
10 in the fluid sample are lysed. Random fragmentation of DNA or RNA is often necessary as a sample pre-treatment step. Fragmentation may be achieved biochemically using restriction enzymes, or through application of a physical force to break the molecules (see, for example, P. N.
15 Hengen, Trends in Biochem. Sci. , vol. 22, pp. 273- 274, 1997 and P. F. Davison, Proc. Nat. Acad. Sci. USA , vol. 45, pp. 1560- 1568, 1959). DNA fragmentation by shearing usually involves passing the sample through a short constriction. In a preferred embodiment, DNA and/or RNA
20 breaks under mechanical force when pumped through a narrow orifice, due to rapid stretching of the molecule. A pressure-driven flow can lead to a shear force, which leads to fragmentation of the nucleic acids. International patent application no. PCT/GB03/004768 describes a microfluidic
25 device for nucleic acid fragmentation.

The lysis unit may itself further comprise means to filter the fluid sample, and optionally also means to fragment nucleic acids.

30

- 16 -

The nucleic acid extraction unit

The nucleic acid extraction unit may have any suitable shape and configuration but will typically be in the form of a channel or chamber. The nucleic acid extraction unit may be
5 at least partially filled with beads, particles, filters or fibres of a material which binds nucleic acid (e.g. mRNA) non-specifically, e.g. silica. Alternatively or additionally, the nucleic acid extraction unit may comprise a silica filter. The nucleic acid binds to silica surfaces
10 in the presence of chaotropic agents. The unit will typically comprise a substrate and an overlying cover, the extraction unit being defined by a recess in a surface of the substrate and the adjacent surface of the cover. The substrate is preferably formed from silicon, PDMS
15 (poly(dimethylsiloxane)), PMMA (Polymethyl methacrylate), COC (Cyclo olefin copolymer), PE (polyethylene), PP (polypropylene), PC (polycarbonate), PL (Polylactide), PBT (Polybutylene terephthalate) and PSU (Polysulfone), including blends of two or more thereof. The preferred
20 polymer is COC. In a particular embodiment, the nucleic acid extraction unit comprises silica bead-packed, particle filters or fibres in a channel.

Whatever the form of the nucleic acid extraction unit, the
25 inventors have found the extraction unit to be more effective if it is treated with hydrogen peroxide before being used. This has been found to produce a sample that can be more reliably amplified. Dilution of the sample once extracted from the nucleic acid extraction unit has also
30 been found to promote selective amplification. This can, for example, be done by having the mixing fluid comprise diluting fluid (e.g. water).

- 17 -

The device may further comprises means for heating the contents of the lysis unit and/or the nucleic acid extraction unit. Said mean may comprise, for example, one
5 or more Peltier elements located in or adjacent the lysis unit and/or the nucleic acid extraction unit.

The reagent storage and actuation unit

In its most general aspect, the present invention comprises
10 three reagent storage reservoirs, namely a lysis fluid reservoir, a first washing buffer reservoir and a eluant fluid reservoir.

In a preferred aspect, these three reservoirs are arranged
15 in parallel. Each reservoir has two ends and these two ends are nominally given the labels upper end and lower end. The upper ends of each reservoir are connected to a first variable-position valve (nominally called the 'upper' variable-position valve) while the lower ends are connected
20 to a second variably-position valve (nominally called the 'lower' variable-position valve). The upper variable position valve is also connected to a single pump that actuates all three reservoirs of fluid. The single pump may also actuate all other fluids pre-loaded into the device and
25 / or the sample once loaded into the device. The lower variable position valve allows the fluids to be transferred in use to the appropriate parts of the device. In order to achieve this, the device is provided with a first actuation channel connecting the lower variable-position valve to the
30 lysis unit and a second actuation channel further connecting the lower variable-position valve to the nucleic acid extraction unit. As a result, in use, appropriate

- 18 -

positioning of the upper and lower variable position valve allows the single pump to actuate the lysis fluid to transfer it through the first actuation channel to the lysis unit and to actuate the first washing buffer and eluant
5 fluid to transfer them through the second actuation channel to the nucleic acid extraction unit.

Optionally, a fourth reservoir is arranged in parallel with the other three reservoirs. This fourth reservoir is a
10 reservoir of second washing buffer for the nucleic acid extraction unit. Again, if the two ends of this reservoir are nominally indicated as the upper end and the lower end, the upper end of this fourth reservoir is connected to the upper variable-position valve and the lower end is connected
15 to the lower variable-position valve. The second washing buffer is actuated by the same pump that actuates the other three reservoirs. In use, the fourth washing buffer is actuated so that it is transferred through the second actuation channel to pass through the nucleic acid
20 extraction unit.

Accordingly, each reservoir is pre-loaded with its respective reagent. The reservoir of lysis fluid is pre-loaded with lysis fluid; the reservoir of first washing
25 buffer is pre-loaded with first washing buffer; the reservoir of eluant is pre-loaded with eluant. Optionally, the reservoir of second washing buffer is pre-loaded with second washing buffer; and the reservoir of mixing fluid is pre-loaded with mixing fluid.

30

By using this particular system, a reagent storage and actuation unit can be used that effectively and efficiently

- 19 -

separates the different fluids so that they do not unintentionally mix during storage or during use. In addition, a single pump can be used to actuate all of the pre-loaded fluids. This simplifies the system and improves
5 its reliability.

The lysis fluid can be any suitable lysis fluid/buffer capable of lysing the cells and/or particles of interest in the fluid sample. An example of a suitable lysis buffer
10 fluid is 100 mM Tris/HCl, 8 M GuSCN (pH 6.4).

The eluant fluid can be any fluid suitable for eluting purified nucleic acids from the nucleic acid extraction unit. An example of a suitable elution buffer is 10 mM
15 Tris/HCl, 1 mM EDTA Na₂ (pH 8).

The first washing solvent may be chosen from any suitable solvent, but preferably is one which can be readily evaporated, for example ethanol.
20

The second washing solvent may be chosen from any suitable solvent, but preferably is one which can be readily evaporated, for example isopropanol.

25 The mixing fluid may also be a part of this reagent storage system (see below). When used, the mixing fluid is generally a reagent which is added to purified nucleic acid eluted from the nucleic acid extraction unit for the purposes of a downstream process or reaction, for example a
30 downstream nucleic acid amplification reaction. In one embodiment the mixing fluid may be DMSO, sorbitol or a mixture thereof. Other mixing fluids are known to the

person skilled in the art (e.g. poly-alcohols, which are molecules having one or more pendant alcohol groups, such as glycerol). As noted above, these particular mixing fluids are provided in particular for NASBA.

5

The two variable position valves of the reagent storage and actuation system operate in concert in order to control the flow of individual reagents stored in the reagent reservoirs through the device. The first variable-position valve is
10 denoted the upper valve and can be variably position to allow fluid communication between the pump and any of the reagent storage channels. It may also be called the pump valve. The second variable position valve is denoted the
15 lower valve and can be variably positioned to selectively establish fluid communication between the actuation channel and each one of the reagent reservoirs, in turn. It may also be called the actuator valve. Only one of the reagent reservoirs is in fluid communication with the actuation
20 channel at any one time, according to the selected position of the actuator valve. The lower valve enables reagent flow from each of the reagent reservoirs to be actuated using a single reagent flow actuator when the device is in use.

The use of the reagent storage and actuation system of the
25 present invention allows the reagent flow through the device from the reagent reservoirs to the lysis unit and the nucleic acid extraction unit to be actuated according to a pre-determined protocol using a single reagent flow actuator when the device is in use.

30

The mixing unit

The device of the present invention may further comprise a separate mixing unit in order to pre-mix a sample with a mixing fluid before the sample is loaded into the first
5 reaction chamber of an amplification unit. The inventors have found that, despite increasing the complexity of the device, this modification of the device in fact provides much more efficient and effective mixing of the sample with the mixing fluid. This can increase of the specificity of
10 an amplification reaction carried out in the downstream amplification unit.

Accordingly, the device may further comprise a mixing unit downstream of the nucleic acid extraction unit so as to
15 receive eluate from the extraction unit when the device is in use. The mixing unit is also in fluid communication with a reagent reservoir pre-loaded with a mixing fluid. The mixing fluid may be a fluid for promoting selective hybridization of an amplification primer to its target.
20 Examples of such solvents include a sulphoxide and / or sorbitol. An example of a sulphoxide is DMSO. The mixing unit is designed to mix eluate from the nucleic acid extraction unit (or a fluid comprising the eluate, e.g. diluted eluate) with the pre-loaded mixing fluid (e.g.
25 DMSO/sorbitol).

The mixing unit may have any suitable shape and configuration.

30 In one embodiment, the reservoir of mixing fluid is stored parallel to the reservoirs of lysis fluid, first washing buffer and eluting fluid. If the two ends of this reservoir

- 22 -

are nominally indicated as the upper end and the lower end, the upper end of the mixing fluid reservoir is connected to the upper variable-position valve and the lower end is connected to the lower variable-position valve. This is a convenient way of allowing this reservoir to be actuated by the same pump as all of the other reservoirs of fluid pre-loaded onto the device. If the mixing reagent is stored in this manner, the device further comprises a third actuation channel connecting the lower variable-position valve and the mixing unit. In use, the mixing fluid may be actuated so that it is transferred through the third actuation channel to the mixing unit. This configuration allows the mixing fluid to be stored and then provided to the mixing unit when required.

15

Accordingly, the mixing unit may be provided with:

- (i) a third variable-position valve,
- (ii) first and second channels having first and second ends, wherein the first ends of the first and second channels are connected to the third variable-position valve, and the second ends of the first and second channels are co-terminus,
- (iii) an elongated channel having first and second ends, wherein the first end of the third channel is co-terminus with the second ends of the first and second channels.

20
25

In use, this configuration allows the sample to be eluted from the nucleic acid extraction unit and then loaded into the first channel. Mixing fluid is then loaded into the second channel. Finally, the eluted sample and solvent are pumped at the same time into the elongated channel.

30

- 23 -

In this configuration, the mixing unit may further comprise a means for measuring the positions (or plugs) of the sample eluted from the nucleic acid extraction unit in the first channel and the mixing fluid in the second channel. This
5 allows precise control of the fluids in order to ensure efficient mixing of the sample with the mixing fluid. The measuring means is preferably an optical system comprising an optical source. In order to simplify the design of the device, the optical source can be the same optical source as
10 that used in the turbidity measurement (see below).

Alternatively, the mixing fluid can be stored in a reservoir having both ends connected to a third variable-position valve. In this case, the mixing channel or chamber may be
15 directly connected to the third variable-position valve so that the device comprises:

a mixing unit comprising a variable-position valve connected to the outlet of the nucleic acid extraction unit and a mixing channel connected to the variable position
20 valve, wherein the mixing fluid reservoir has both ends directly connected to the third variable position valve. The inventors have found that this is advantageous because it simplifies the operation of the mixing unit. In
25 particular, it means that the device can be operated with either a simplified detection system for measuring the position of the sample before being loaded into the mixing channel or chamber or without any detection system at all. This has been found to increase the reliability of the device.

30

In whatever embodiment, the channel or chamber in which the sample and the mixing fluid mix is typically in the form of

- 24 -

an elongated channel, possibly containing inlays or structured side walls to promote mixing. The elongated channel may be convoluted, e.g. sinuate. In order to achieve mixing of the eluate with the downstream reagent, the two fluids are combined and flowed along the elongated channel of the mixing unit. The elongated channel provides a flow path of sufficient length to enable the two fluids to mix by simple diffusion.

10 It should be noted that the third variable-position valve described above may facilitate control of other parts of the device. Alternatively, a separate variable position valve may be provided to facilitate actuation of the fluids around the device. In either case, the valve may operate in concert with the first and second variable-position valves. As such, it is denoted the reagent flow path control valve. This valve's roles can be to be positioned to establish fluid communication between a selected reservoir and either the lysis unit, the nucleic acid extraction unit or (in the case of reservoir pre-loaded with mixing fluid) the mixing unit. Only one of the reagent reservoirs is in fluid communication with the lysis unit, the nucleic acid extraction unit, or mixing unit (if present) at any one time, according to the selected position of the flow path control valve.

Other features

The device according to the present invention will typically further comprise a waste unit in fluid communication with any one or any combination of the sample inlet, the lysis unit, and the nucleic acid extraction unit. Optional valves may be present to control the flow of fluid to the waste

- 25 -

unit. The waste unit may be microfabricated and integrated with the other components.

The device is intended to be used in conjunction with a reagent flow actuator which is a means for introducing air (or other fluid) into device. For example, the reagent flow actuator may be connected to the reagent storage system. The reagent flow actuator may form part of the device or may be a separate component used in conjunction with the device. The reagent flow actuator may comprise a pump or a syringe, or a variable volume chamber in communication with the reagent storage system.

The device may further comprise, or be used in conjunction with, means for introducing a fluid sample into the sample inlet. Said means may comprise a pump or a syringe. Alternatively, such means may comprise one or more variable volume chambers in communication with the sample inlet, wherein altering the volume of the variable volume chamber(s) effects and/or restricts flow of a fluid sample into and/or out of the inlet. The variable volume chamber typically comprises a flexible membrane overlying a hollow recess in the underlying substrate. International patent application no. PCT/GB02/005945 describes a preferred fluid transport system.

The device may further comprise a turbidity sensor. The sensor may be upstream of the filtration unit. In order to simplify the design of the device, his sensor may use the same optical source as the position sensors of the mixing system.

- 26 -

The device may further comprise a pressure sensor.

Preferably, the pressure sensor is dead-end pressure sensor rather than an in-line pressure sensor because the inventors have found that the use of a dead-end pressure sensor
5 prevents contamination between different samples extracted and purified on the same chip.

A system for carrying out nucleic acid extraction, amplification and detection

10 The invention also provides an integrated lab-on-a-chip diagnostic system for carrying out nucleic acid extraction and a nucleic acid sequence amplification and detection process on a fluid sample containing cells and/or particles, the system comprising a nucleic acid extraction device
15 according to the first or second aspects of the invention and a nucleic acid amplification unit.

Typically, the nucleic acid amplification unit will be in fluid communication the nucleic acid extraction unit, or the
20 mixing unit if present, such that the eluate from the nucleic acid extraction unit, or a mixture thereof with the solvent, can flow directly to the nucleic acid amplification unit. An optional valve may be present to control the flow of fluid therebetween. Preferably, the nucleic acid
25 reaction unit is microfabricated and preferably integrated with the other components.

Any conventional reaction may be carried out in the reaction unit. In a particular embodiment, the reaction will enable
30 detection and/or quantitation of specific target nucleic acid sequence. The nucleic acid reaction unit will typically comprise a nucleic acid sequence amplification

- 27 -

unit, which enables detection of specific sequences by a nucleic acid amplification reaction. Examples include PCR and isothermal amplification techniques such as nucleic acid sequence-based amplification (NASBA). The most preferred is
5 real-time NASBA using molecular beacon probes for detection of the amplification products.

Accordingly, in a preferred aspect, the present invention provides an integrated lab-on-a-chip diagnostic system for
10 carrying out a sample preparation, nucleic acid sequence amplification and detection process on a fluid sample containing cells and/or particles, more preferably real time NASBA. The general features and requirements of the NASBA reaction are well known in the art. International patent
15 application publication no. WO 02/22265 (whose contents is incorporated by reference) describes a microfabricated reaction chamber system for carrying out NASBA which can be adapted for inclusion in the system of the invention.

20 The nucleic acid reaction unit may have any suitable configuration. In an embodiment the reaction unit may comprise a plurality of parallel reaction channels or chambers. In one embodiment the reaction chambers/channels may be pre-loaded with reagents required for nucleic acid
25 amplification and/or detection, e.g. reagents required for real-time NASBA. Such reagents may include enzymes, buffer components, NTPs, primers, probes etc. Reagents may be stored in a dried state and reconstituted immediately prior to use, e.g. by addition of the fluid nucleic acid sample
30 prepared in the sample preparation portion of the system.

- 28 -

In one preferred embodiment, the primers for nucleic acid amplification are pre-loaded into the amplification unit. The combination of pre-loading the primers and mixing a mixing fluid with the nucleic acid sample in the mixing unit
5 of the present invention helps to promote the specific binding of the primers to their targets. The primers may be pre-loaded into the first chambers of a plurality of two chambers arranged in parallel. Each first chamber may be connected to a common inlet port. In this case,
10 amplification enzymes such as NASBA enzymes are provided, preferably pre-loaded, in the second chamber. All other reagents may be provided, preferably pre-loaded, into the first chamber.

15 The term "*pre-loading*" means that reagents are added to the device prior to its end use, for example during the device's manufacture. As such, solid reagents may be deposited on the device by, for example, drying a solution of the reagent by allowing the solvent in the solution to evaporate.

20

The nucleic acid reaction unit may further include metering means for metering aliquots of the fluid nucleic acid sample as they are introduced into the parallel reaction chambers/channels. This metering means may take any
25 convenient form.

In a particular embodiment, the system according to the present invention can be used for lysis of cells present in a fluid sample, extraction of mRNA, NASBA amplification of
30 one or more specific target sequences and real-time detection of the amplification products.

Microfabrication of the system

Individual components of the device may be microfabricated. In one embodiment the lysis unit, the nucleic acid extraction unit, and the reagent reservoirs of the reagent
5 storage and actuation system are microfabricated and integrated, i.e. formed on a common substrate.

The system or at least a master version thereof will typically be formed from or comprise a semiconductor
10 material, although dielectric (eg glass, fused silica, quartz, polymeric materials and ceramic materials) and/or metallic materials may also be used. Examples of semiconductor materials include one or more of: Group IV elements (i.e. silicon and germanium); Group III-V
15 compounds (eg gallium arsenide, gallium phosphide, gallium antimonide, indium phosphide, indium arsenide, aluminium arsenide and aluminium antimonide); Group II-VI compounds (eg cadmium sulphide, cadmium selenide, zinc sulphide, zinc selenide); and Group IV-VI compounds (eg lead sulphide,
20 lead selenide, lead telluride, tin telluride). Silicon and gallium arsenide are preferred semiconductor materials. The system may be fabricated using conventional processes associated traditionally with batch production of
semiconductor microelectronic devices, and in recent years,
25 the production of semiconductor micromechanical devices. Such microfabrication technologies include, for example, epitaxial growth (eg vapour phase, liquid phase, molecular beam, metal organic chemical vapour deposition), lithography (eg photo-, electron beam-, x-ray, ion beam-), etching (eg
30 chemical, gas phase, plasma), electrodeposition, sputtering, diffusion doping, ion implantation and micromachining. Non-

- 30 -

crystalline materials such as glass and polymeric materials may also be used.

Examples of polymeric materials include PMMA, PDMS
5 (poly(dimethylsiloxane)), PC (Polycarbonate), (Polymethyl
methylacrylate), COC (Cyclo olefin copolymer), PE
(Polyethylene), PP (Polypropylene), PL (Polylactide), PBT
(Polybutylene terephthalate) and PSU (Polysulfone),
including blends of two or more thereof. The preferred
10 polymer is PDMS or COC..

The device or system will typically be integrally formed.
The device or system may be microfabricated on a common
substrate material, for example a semiconductor material as
15 herein described, although a dielectric substrate material
such as, for example, glass or a ceramic material could be
used. The common substrate material is, however, preferably
a plastic or polymeric material and suitable examples are
given above. The device or system may preferably be formed
20 by replication of, for example, a silicon master.

The advantages of using plastics instead of silicon-glass
for miniaturized structures are many, at least for
biological applications. One of the greatest benefits is the
25 reduction in cost for mass production using methods like
microinjection moulding, hot embossing and casting. A
factor of a 100 or more is not unlikely for complex
structures. The possibility to replicate structures for
multilayered mould inserts gives a great flexibility of
30 design freedom. Interconnection between the micro and macro
world are in many cases easier because one got the option to
combine standard parts normally used. Different approaches

- 31 -

can be used for assembly techniques, like e.g. US-welding or solvent-welding with support of microstructures, laser welding, gluing and lamination. Other features that are profitable is surface modification. For miniaturized structures addressed for biological analysis, it is important that the surface is biocompatible. By utilizing plasma treatment and plasma polymerization a flexibility and variation of assortment can be adapted into the coating. Chemical resistance against acids and bases are much better for plastics than for silicon substrates that are easily etched away. Most detection methods within the biotechnological field involves optical measurements. The transparency of plastic is therefore a major feature compared to silicon that are not transparent. Polymer microfluidic technology is now an established yet growing field within the lab-on-a-chip market.

The microfabricated device or system as herein described is also intended to encompass nanofabricated devices.

For a silicon or semiconductor master, it is possible to define by, for example, etching or micromachining, one or more of variable volume chambers, microfluidic channels, reaction chambers and fluid interconnects in the silicon substrate with accurate microscale dimensions. A plastic replica may then be made of the silicon master. In this manner, a plastic substrate with an etched or machined microstructure may be bonded by any suitable means (for example using an adhesive or by heating) to a cover.

30

Method of using the device

The devices and system of the present invention can be used according to the fourth of fifth aspects of the present invention. These method steps are summarized below:

5

(i) The sample is loaded through the sample inlet,

(ii) the turbidity and / or pressure of the sample are optionally measured,

10 (iii) the sample passes optionally to a filtration unit,

(iv) the fluid from the sample is optionally transferred to the waste unit,

15 (v) lysis fluid is transferred from the lysis fluid reservoir and onto the cells and / or particles of the sample; this may be carried out by passing the lysis fluid through the first actuation channel,

(vi) the lysis fluid is then passed into the nucleic acid extraction unit,

20 (vii) the fluid remaining after being passed through the nucleic acid extraction unit is optionally transferred to the waste unit,

25 (viii) first washing buffer is transferred from the first washing buffer reservoir through the nucleic acid extraction unit and then optionally transferred to the waste unit; this may be carried out by passing the first washing buffer from the first washing buffer reservoir through the second actuation channel,

30 (ix) second washing buffer is optionally transferred from the second washing buffer reservoir through the nucleic acid extraction unit and then optionally transferred to the waste unit; this may be achieved by

- 33 -

passing the first washing buffer from the first washing
buffer reservoir through the second actuation channel,
(x) eluant fluid is transferred from the eluant
reservoir through the second actuation channel through
5 the nucleic acid extraction unit,
(xi) optionally, the eluted sample is then transferred
to a mixing unit,
(xii) in the mixing unit, the eluted sample is
mixed with mixing fluid,
10 (xiii) then the sample is transferred to the
amplification unit.

In the amplification unit, the sample may be:

(xiv) transferred to a first chamber and heated to
15 60°C or above, and then
(xv) transferred to a second chamber containing NASBA
enzymes and heated to about 40°C.

It is apparent from the previous description of the first,
20 second and third aspects of the present invention that
modifications, additions and deletions can be made to this
sequence of steps.

Fabrication of the device

25 The present invention also provides a method for the
manufacture of an integrated lab-on-a-chip diagnostic system
as herein described which method comprises:

- A. providing a substrate having an inlet recess, a lysis
unit recess, a nucleic acid extraction unit recess, a lysis
30 fluid reservoir recess and an eluant reservoir recess in a
surface thereof;
B. providing a cover; and

C. bonding the cover to the substrate to create the (a) inlet, (b) the lysis unit, (c) the nucleic acid extraction unit, (d) the lysis fluid reservoir and (e) the eluant reservoir, each being defined by the respective recess in
5 said surface of the substrate and the adjacent surface of the cover.

The term recess as used herein is also intended to cover a variety of features including, for example, grooves, slots,
10 holes, trenches and channels, including portions thereof.

The method may further comprise the step of introducing lysis fluid into the lysis fluid reservoir either before or after bonding the cover to the substrate.

15

The method may further comprise the step of introducing eluant into the eluant reservoir either before or after bonding the cover to the substrate.

20 The method may further comprise the step of introducing e.g. ethanol into the first washing solvent reservoir either before or after bonding the cover to the substrate.

The method may further comprise the step of introducing e.g.
25 isopropanol into the washing solvent reservoir either before or after bonding the cover to the substrate.

The substrate may be formed from silicon, for example, and the overlying cover from glass, for example. In this case,
30 the glass cover is preferably anodically bonded to the silicon substrate, optionally through an intermediate silicon oxide layer formed on the surface of the substrate.

- 35 -

The recesses in the silicon may be formed using reactive-ion etching. Other materials such as polymeric materials may also be used for the substrate and/or cover. Such materials may be fabricated using, for example, a silicon replica.

5 Alternatively, the device may be fabricated by structuring of mould inserts by milling and electro-discharge machining (EDM), followed by injection moulding of the chip parts, followed by mechanical post-processing of the polymer parts, for example drilling, milling, deburring. This may
10 subsequently be followed by insertion of the filter, solvent bonding, and mounting of fluidic connections.

Examples of polymeric materials include PMMA (Polymethyl methacrylate), COC (Cyclo olefin copolymer), PDMS
15 (poly(dimethylsiloxane)) PE (Polyethylene), PP (Polypropylene), PC (Polycarbonate), PL (Polylactide), PBT (Polybutylene terephthalate) and PSU (Polysulfone), including blends of two or more thereof. COC is preferred.

20 Preferably, and in particular if optical observations of the contents of the cell are required, the overlying cover is made of an optically transparent substance or material, such as glass, Pyrex or COC.

25 Combinations of a microfabricated component with one or more other elements such as a glass plate or a complementary microfabricated element are frequently used and intended to fall within the scope of the term microfabricated used herein.

30

Part or all of the substrate base may be provided with a coating of thickness typically up to 1 μm , preferably less

- 36 -

than 0.5 μm . The coating is preferably formed from one or more of the group comprising polyethylene glycol (PEG), Bovine Serum Albumin (BSA), tweens and dextrans. Preferred dextrans are those having a molecular weight of 9,000 to 5 200,000, especially preferably having a molecular weight of 20,000 to 100,000, particularly 25,000 to 75,000, for example 35,000 to 65,000). Tweens (or polyoxyethylene sorbitans) may be any available from the Sigma Aldrich Company. PEGs are preferred as the coating means, either 10 singly or in combination. By PEG is embraced pure polyethylene glycol, i.e. a formula $\text{HO}-(\text{CH}_2\text{CH}_2\text{O})_n\text{-H}$ wherein n is an integer whereby to afford a PEG having molecular weight of from typically 200 - 50,000, especially PEG 1,000 to 20,000; for example 15,000 to 20,000 or chemically 15 modified PEG wherein one or more ethylene glycol oligomers are connected by way of homobifunctional groups such as, for example, phosphate moieties or aromatic spacers. Particularly preferred are polyethylene glycols PEG having a number-average molecular weight of 15,000 to 20,000. An 20 example of this PEG is sold by the Sigma Aldrich Company as product P2263. The above coatings applied to the surfaces of the cell/chamber, inlets, outlets, and/or channels can improve fluid flow through the system. In particular, it has been found that the sample is less likely to adhere or 25 stick to such surfaces. PEG coatings are preferred.

For a silicon or semiconductor master, it is possible to define by, for example, etching or micromachining, one or more of variable volume chambers, microfluidic channels, 30 reaction chambers and fluid interconnects in the silicon substrate with accurate microscale dimensions (deep reactive-ion etching (DRIE) is a preferred technique). A

- 37 -

plastic replica may then be made of the silicon master. In this manner, a plastic substrate with an etched or machined microstructure may be bonded by any suitable means (for example using an adhesive or by heating) to a cover thereby forming the enclosed fragmentation cell(s), inlet(s), outlet(s) and connecting channel(s).

In general, it is preferable for the device to be fabricated by injection molding of a plastic, for example COC. This allows facile and convenient manufacture of the device.

The device comprises a substrate with the desired microstructure formed in its upper surface. The substrate may be silicon, for example, or a plastic substrate formed by replication of a silicon master. The substrate is bonded at its upper surface to a cover, thereby defining a series of units/cells, inlets, outlets, and/or channels. The cover may be formed from plastic or glass, for example. The cover is preferably transparent and this allows observation of the fluid. If the device is to be made from silicon, it may be made by DRIE or the device may be fabricated by structuring of mould inserts by milling and electro-discharge machining (EDM), followed by injection moulding of the chip parts, followed by mechanical post-processing of the polymer parts, for example drilling, milling, deburring. This may subsequently be followed by insertion of the filter, solvent bonding, and mounting of fluidic connections.

The fluid sample may be or be derived from, for example, a biological fluid, a dairy product, an environmental fluid and/or drinking water, or a fluid sample containing cells obtained or derived from a clinical tissue sample, e.g. a

biopsy or similar tissue sampling method, e.g. cervical scrapings. Non-limiting examples include blood, serum, saliva, urine, milk, drinking water, marine water and pond water. For many complicated biological samples such as, for
5 example, blood and milk, it will be appreciated that before one can isolate and purify DNA and/or RNA from bacterial cells and virus particles in a sample, it is first necessary to separate the virus particles and bacterial cells from the other particles in sample. It will also be appreciated that
10 it may be necessary to perform additional sample preparation steps in order to concentrate the bacterial cells and virus particles, i.e. to reduce the volume of starting material, before proceeding to break down the bacterial cell wall or virus protein coating and isolate nucleic acids. This is
15 important when the starting material consists of a large volume, for example an aqueous solution containing relatively few bacterial cells or virus particles. This type of starting material is commonly encountered in environmental testing applications such as the routine
20 monitoring of bacterial contamination in drinking water.

The device or system is preferably designed to cater for a sample volume of 1-100 ml.

25 The present invention also provides an apparatus for the analysis of biological and/or environmental samples, the apparatus comprising a system as herein described. The apparatus may be a disposable apparatus.

30 The present invention will now be described, by way of example, with reference to the accompanying drawings.

- 39 -

A typically device layout is illustrated schematically in Figure 1. The device comprises an inlet 1 for a fluid sample, a lysis unit with integrated filter 4, a nucleic acid extraction unit 5 and a mixing unit 6. The device is provided with reservoirs of lysis fluid (7), first buffer solution (8), eluant fluid (9), optionally second buffer solution (10) and mixing fluid (11).

In use, fluid is passed into the sample inlet. It may be actively pumped into the inlet by action of, for example, a syringe. Alternatively, a pump may be provided in fluid communication with the inlet so that sample is sucked into the fluid inlet from a passive storage system. This pump may be the same as or different to the pump 27 for actuating the fluids that are pre-loaded into the device.

Optionally, the system may comprise a turbidity sensor 2 and / or a pressure sensor 3. Turbidity may also measured via optical sensor assembly 2 by measuring passing and scattered light as an indicator of glycoprotein content and cell number of the sample. Pressure may be measured by the pressure sensor 3 as an indication of filter load. In use, if the sample does not have pre-determined levels of pressure and turbidity, the sample may be rejected.

25

In use, fluid from the sample may be passed to the waste unit 12 once the sample has been optionally filtered. In addition, the lysis fluid and first buffer solution may be passed to a waste unit 12 when eluted from the nucleic acid extraction unit. These two outlets are shown as different outlets in Figure 1. In this case, optional valves 15 and 16 may be used to control the flow of fluids through the

30

- 40 -

fluid pathway or to the waste unit. However, more convenient approach is shown in Figure 2. In this Figure, a single waste unit is provided. This is shown having an optional outlet so that pressure does not build up in the system. This outlet also allows gas to be released from the system during the optional air drying step of the nucleic acid purification unit. Furthermore, the flow of reagents around the chip may be controlled by one variable-position valve, referred to previously as the third variable-position valve or actuation valve. Although not shown in Figure 2, this third variable-position valve may be provided in combination with its other functions shown in Figure 2 or as a separate variable-position valve to provide mixing fluid 11 to the mixing unit 6.

15

The reagents 7, 8, 9 and 10 may be provided in parallel reagent reservoirs. An exemplary arrangement of three parallel reservoirs is shown in Figure 3. In this Figure, reservoirs 20, 21 and 22 are each joined at either end to variable-position valves 23 (the upper variable-position valve) and 24 (the lower variable-position valve). Reservoir 20 contains reagent 7, reservoir 21 contains reagent 8 and reservoir 22 contains reagent 9. Optionally one or two further parallel reagent reservoirs may be provided. These may contain the mixing fluid and / or the second washing buffer.

25

The upper variable position valve is connected to a pump 27. This pump preferably actuates all of the reagents 7, 8, 9 and, if present, 10 and 11, on the device.

30

- 41 -

The lower variable position valve is connected to first and second actuation channels 25 and 26. The first actuation channel is connected to the lysis unit so that, in use, the lysis fluid may be actuated by the pump 27 and supplied to the lysis unit through the first actuation channel. The second actuation channel is connected to the nucleic acid extraction unit so that, in use, first washing buffer and eluant fluid may be supplied to the nucleic acid extraction unit through the second actuation channel.

10

As will be appreciated, the concerted control of the upper and lower variable-position valves can be used to actuate all the fluids that are pre-loaded onto the device. This control can be further improved by the use of a third variable-position valve as shown in Figure 2.

15

The nucleic acid extraction unit may contain silica beads, for example 0.3 mg of 15-30 μm size silica beads.

Electrodes may be also provided (not shown) just below the packed bed for electrokinetic collection of the negatively charged, eluting nucleic acids.

20

Two possible configurations for the mixing unit 6 are shown in Figures 4 and 5. In Figure 4, the third variable-position valve 33 is used to position eluted sample from the nucleic acid extraction unit 5 in a first channel 30. Then, the mixing fluid 11 from the mixing fluid reservoir is loaded through the third variable-position valve 33 into a second channel 31. Once loaded, both channels are actuated. Since the channels are co-terminus at the start of the elongated mixing channel 32, the mixing fluid and eluted sample pass into the elongated mixing channel and mix. The

25

30

- 42 -

shape of the elongated mixing channel encourages complete mixing of the sample and mixing fluid.

In Figure 4, preferably the position of the plugs of the mixing fluid and eluted sample are measured by an optical instrument. Preferably, this optical instrument is the same optical instrument that undertakes the turbidity measurement on the sample. This is shown by the arrows in Figure 2: a single optical detector array is provided that detects light for both the turbidity measurement (52) and the positioning of the plugs of the sample and mixing fluid in the mixing unit 55.

Figure 5 shows an alternative configuration to Figure 4. In particular, a third variable position valve 33 is provided directly connected to a mixing channel 32. This third variable position valve is also connected to both ends of the mixing fluid reservoir, shown as 34. The valve is also connected to the outlet of nucleic acid extraction unit 5. In use, the variable-position valve allows the mixing fluid and the sample eluted from the nucleic acid extraction unit to be mixed directly in the mixing channel without the need for a complicated optical system to measure the position of the plugs (i.e. fore-most points) of both the sample and the mixing fluid.

Accordingly, in use, a sample loaded into the device undergoes several steps as shown in Figure 6. Step 1 is the sample loading. 1-20ml of fluid sample is introduced into the device via sample inlet, for example using a syringe pump, and flows through the lysis/filtration unit to waste. Cells and/or particles present in the sample are retained by

- 43 -

the filter in the lysis unit. Pressure is measured using a pressure guage as an indication of filter load. Turbidity is also measured via optical sensor assemble measuring passing and scattered light as an indicator of glycoprotein content and cell number of the sample.

Step 2 is the lysis. Lysis fluid is transferred from a reagent reservoir pre-loaded with lysis solution, for example through the first actuation channel. The lysis fluid is then transferred to the nucleic acid extraction unit. Cells and/or particles retained on the filter in step 1 are lysed to release their contents, the lysed sample then passes to the nucleic acid extraction unit. Nucleic acids present in the lysed sample are bound by the silica beads in the nucleic acid extraction unit and retained. Fluid exits the extraction unit and exits to the waste. If a variable-position valve is positioned connected to the outlet of the extraction unit, the valve is positioned to allow fluid flowing through the nucleic acid extraction unit to exit to the waste. In this step, all the fluids may be actuated by a single pump.

Step 3 is the first wash. The first wash solvent is transferred to the nucleic acid extraction unit, preferably through the second actuation channel. A third variable-position valve connected to the outlet of the nucleic acid extraction chamber may be positioned to allow fluid flowing through the nucleic acid extraction unit to exit to waste. All fluids may be actuated by the same single pump as in the previous step.

- 44 -

Step 4 is the optional second wash, e.g. with isopropanol. The details of this wash are the same as that for the first wash. Again all fluids may be actuated by the same single pump as in steps 2 to 4.

5

Step 5 is air drying and heating. The single pump used to actuate all fluids in steps 2 to 4 is used again to pump air through the nucleic acid extraction unit. This is achieved by, for example, leaving the fluid pathway open that allowed the second washing buffer to be pumped into the nucleic acid extraction unit. The chamber may be heated if required.

Step 6 is the elution of nucleic acid. Eluant fluid is pumped from the eluant reservoir with the same single pump used to actuate all fluids in steps 2 to 5. If present, the third variable-position valve is positioned to allow fluid flowing through the nucleic acid extraction unit to exit to the mixing unit. Nucleic acid is eluted from the nucleic acid extraction chamber and transported to the mixing unit. An optical sensor can be used to monitor arrival of eluted nucleic acid at the mixing unit.

Step 7 is the mixing. As noted previously, the exact details of this mixing step depends on the make-up of the mixing unit.

Once mixed with the mixing fluid, the sample passes to a nucleic acid amplification unit.

In one embodiment, the nucleic acid amplification unit comprises a series of two chambers as illustrated in Figure 7. In the first chamber 40, the primers for the

- 45 -

amplification reaction are pre-loaded. They may be pre-loaded in dried form. The primers may be provided similarly pre-loaded for other configurations of nucleic acid amplification units.

5

In Figure 7, if NASBA is to be carried out in the reaction chamber system, NASBA reagents are preloaded into the second chamber 41. All other reagents may also be provided preloaded in either the first or second reaction chambers or both.

10

Figure 8 shows one possible configuration of the device of the present invention. The figure shows a sample inlet (50), a pressure sensor (51), a turbidity sensor (52) designed so that it can also be used to measure the position of the fluid in the mixing unit (55), an integrated filtration and lysis unit (53), a nucleic acid extraction unit (54), a waste unit (56), a pump (57) for actuating all fluids on the device, upper and lower variable position valves (58 and 59), a third variable position valve for both position the sample and mixing fluid in the mixing unit and for controlling the flow of fluids around the device and to the waste unit (56), reagent storage reservoirs (61, 62, 63, 64 and 65), and specific actuation channels connecting the lower variable position valve to the lysis unit, nucleic acid extraction unit and mixing unit (66, 67 and 68). A channel is seen leaving the elongated channel of the mixing unit (55), which connects to a nucleic acid amplification unit (not shown).

15

20

25

30

Figure 9 shows an alternative configuration of the mixing unit. A variable-position valve (72) is used to control a

- 46 -

mixing fluid reservoir (70). The valve is connected to a mixing channel (71). Sample is provided from the nucleic acid extraction unit through an actuation channel (74).

5 Accordingly, the device of the present invention can be used on millilitre sample volumes for routine diagnostics. This has been demonstrated by the present inventors on samples containing between 50 and 50000 cells. In particular, primers for HPV16 were provided in the nucleic acid
10 amplification unit and NASBA was used to amplify the RNA extracted from cells. The above protocols were followed. In particular, 3 ml of sample was loaded into the sample inlet. The system was fabricated from COC. The silica in the nucleic acid extraction unit was pre-treated for 24
15 hours with 3% hydrogen peroxide. A "Genomed A" silica filter was used.

Once the sample was loaded, 120 μ l of 'Biomerieux Buffer pH 7.5' was used as the lysis fluid. Then, 230 μ l of 75%
20 ethanol in water was used as the first washing buffer. The second washing buffer consisted of 100% ethanal. The nucleic acid extraction unit was dried with 7 times 4 ml air supplied at 1.5 ml / minute, the 1 times 2 ml air supplied at 1.5 ml / minute. Drying of the nucleic acid extraction
25 unit then took place at 60°C for 20 minutes. NASBA was then performed on the sample using primers for HPV16. A positive result was observed for the sample.

CLAIMS:

1. An integrated lab-on-a-chip device for carrying out a nucleic acid extraction process on a fluid sample containing
5 cells and/or particles, the device comprising:
- (a) a sample inlet for loading of a fluid sample,
 - (b) a lysis unit for lysis of cells and/or particles present in the fluid sample,
 - (c) a reservoir of lysis fluid for the lysis unit,
 - 10 (d) a nucleic acid extraction unit downstream of the lysis unit, and
 - (e) reservoirs of first washing buffer and eluant fluid for the nucleic acid extraction unit,
- the device further comprising:
- 15 (f) a mixing unit downstream of the nucleic acid extraction unit, and
 - (g) a source of mixing fluid for the mixing unit.
2. The integrated lab-on-a-chip device of claim 1, further
20 comprising:
- (h) a filtration unit that is either upstream of the lysis unit or integrally formed with the lysis unit.
3. The integrated lab-on-a-chip device of claim 1 or claim
25 2, wherein the reservoirs of lysis fluid, first washing buffer and eluant fluid are arranged in parallel, each reservoir having an upper end and a lower end, wherein the device further comprises:
- 30 (i) an upper variable-position valve connected to the upper ends of the reservoirs of lysis fluid, first washing buffer and eluant fluid,

- 48 -

(g) a pump connected to the upper variable-position valve,

(h) a lower variable-position valve connected to the lower ends of the at least three fluid reservoirs,

5 (j) a first actuation channel connecting the lower variable-position valve to the lysis unit, and

(k) a second actuation channel connecting the lower variable-position valve to the nucleic acid extraction unit,

10 wherein at least the lysis fluid, first washing buffer and eluant fluid are actuated by the single pump (g).

4. The device of any one of the preceding claims further comprising:

15 (l) a reservoir of second washing buffer for the nucleic acid extraction unit arranged in parallel with the reservoirs of lysis fluid, first washing buffer and eluant fluid,

20 wherein the reservoir of second washing buffer has an upper end and a lower end, the upper end of the reservoir being connected to the upper variable-position valve and the lower end of the reservoir being connected to the lower variable-position valve, and wherein the second washing buffer is actuated by the single pump (g).

25

5. The device of any one of the preceding claims, wherein the mixing fluid comprises DMSO, sorbitol or a mixture thereof.

30 6. The device of any one of the preceding claims, wherein the mixing fluid is actuated by the single pump (g).

- 49 -

7. The device of claim 6, wherein the reservoir of mixing fluid is arranged parallel to the reservoirs of lysis fluid, first washing buffer and eluant fluid and has an upper end and a lower end, wherein the upper end is connected to upper
5 variable-position valve and the lower end is connected to the lower variable-position valve.

8. The device of claim 7, wherein the device further comprises a third actuation channel connecting the lower
10 variable-position valve with the mixing unit.

9. The device of any one of the preceding claims, wherein the mixing unit comprises:

- 15 (i) a third variable-position valve downstream of the nucleic acid extraction unit and connected to the reservoir of mixing fluid, and
(ii) a mixing channel downstream of the third variable-position valve.

20 10. The device of any one of the preceding claims, wherein the device further comprises a turbidity sensor positioned to determine the turbidity of a fluid sample loaded via the sample inlet.

25 11. The device of any one of the preceding claims, wherein the device further comprises a pressure sensor positioned to determine the pressure of a fluid sample laded via the sample inlet.

30 12. The device of any one of the preceding claims, wherein the device further comprises:

- 50 -

(m) a waste unit, wherein the waste unit is in fluid communication with the lysis unit and/or the nucleic acid extraction unit.

5 13. The device of any one of the preceding claims, wherein the device further comprises means for heating the contents of the lysis unit and/or the nucleic acid extraction unit.

10 14. The device of claim 13, wherein the means for heating comprises one or more Peltier elements located in or adjacent the lysis unit and/or the nucleic acid extraction unit.

15 15. An integrated lab-on-a-chip device for carrying out a nucleic acid extraction process on a fluid sample containing cells and/or particles, the device comprising:

- (a) a sample inlet for loading of a fluid sample,
- (b) a lysis unit for lysis of cells and/or particles present in the fluid sample,
- 20 (c) a reservoir of lysis fluid for the lysis unit,
- (d) a nucleic acid extraction unit downstream of the lysis unit, and

(e) reservoirs of first washing buffer and eluant fluid for the nucleic acid extraction unit,
25 wherein the reservoirs of lysis fluid, first washing buffer and eluant fluid are arranged in parallel, each reservoir having an upper end and a lower end, wherein the device further comprises:

- (i) an upper variable-position valve connected to the
30 upper ends of the reservoirs of lysis fluid, first washing buffer and eluant fluid,

(g) a pump connected to the upper variable-position valve,

(h) a lower variable-position valve connected to the lower ends of the at least three fluid reservoirs,

5 (j) a first actuation channel connecting the lower variable-position valve to the lysis unit, and

(k) a second actuation channel connecting the lower variable-position valve to the nucleic acid extraction unit.

10

16. An integrated lab-on-a-chip diagnostic system for carrying out nucleic acid extraction and a nucleic acid sequence amplification and detection process on a fluid sample containing cells and/or particles, the system

15 comprising:

a nucleic acid extraction device according to any one of claims 1 to 15, and

a nucleic acid reaction unit.

20 17. A system as claimed in claim 16 wherein the nucleic acid extraction device and the nucleic acid reaction unit are integrally formed.

25 18. A method of carrying out a nucleic acid extraction process on a fluid sample containing cells and/or particles using an integrated lab-on-a-chip device, the method comprising:

30 (i) providing an integrated lab-on-chip device comprising a sample inlet, a lysis unit, a nucleic acid extraction unit, a mixing unit, and reservoir of lysis fluid, first washing buffer, eluant fluid and mixing fluid,

- 52 -

(ii) loading a sample through the sample inlet of the device,

(iii) carrying out lysis on the cells and / or particles of the sample by passing lysis fluid from the lysis fluid reservoir over the cells and / or particles,

(iv) passing the lysis fluid through the nucleic acid extraction unit to extract nucleic acids,

(v) transferring first washing buffer from the first washing buffer reservoir through the nucleic acid extraction unit,

(vi) transferring eluant fluid from the eluant reservoir through the nucleic acid extraction unit to produce an eluted sample from the nucleic acid extraction unit, and

(vii) mixing the eluted sample with mixing solvent in the mixing unit.

19. A method of carrying out a nucleic acid extraction process on a fluid sample containing cells and/or particles using an integrated lab-on-a-chip device, the method comprising:

(i) providing an integrated lab-on-chip device comprising a sample inlet, a lysis unit, a nucleic acid extraction unit, a mixing unit, and reservoir of lysis fluid, first washing buffer, eluant fluid and mixing fluid,

(ii) loading a sample through the sample inlet of the device,

(iii) carrying out lysis on the cells and / or particles of the sample by passing lysis fluid from the

lysis fluid reservoir over the cells and / or particles,

(iv) passing the lysis fluid through the nucleic acid extraction unit to extract nucleic acids,

5 (v) transferring first washing buffer from the first washing buffer reservoir through the nucleic acid extraction unit, and

(vi) transferring eluant fluid from the eluant reservoir through the nucleic acid extraction unit to
10 produce an eluted sample from the nucleic acid extraction unit,

wherein the lysis fluid, first washing buffer and eluant fluid are actuated by a single pump.

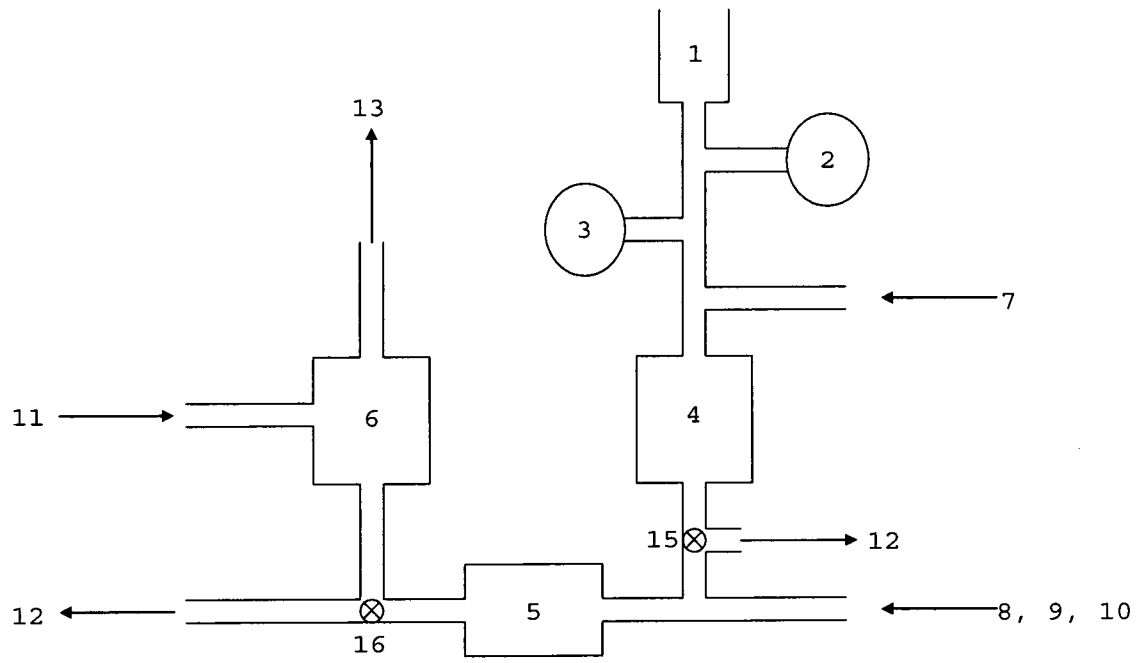

Figure 1

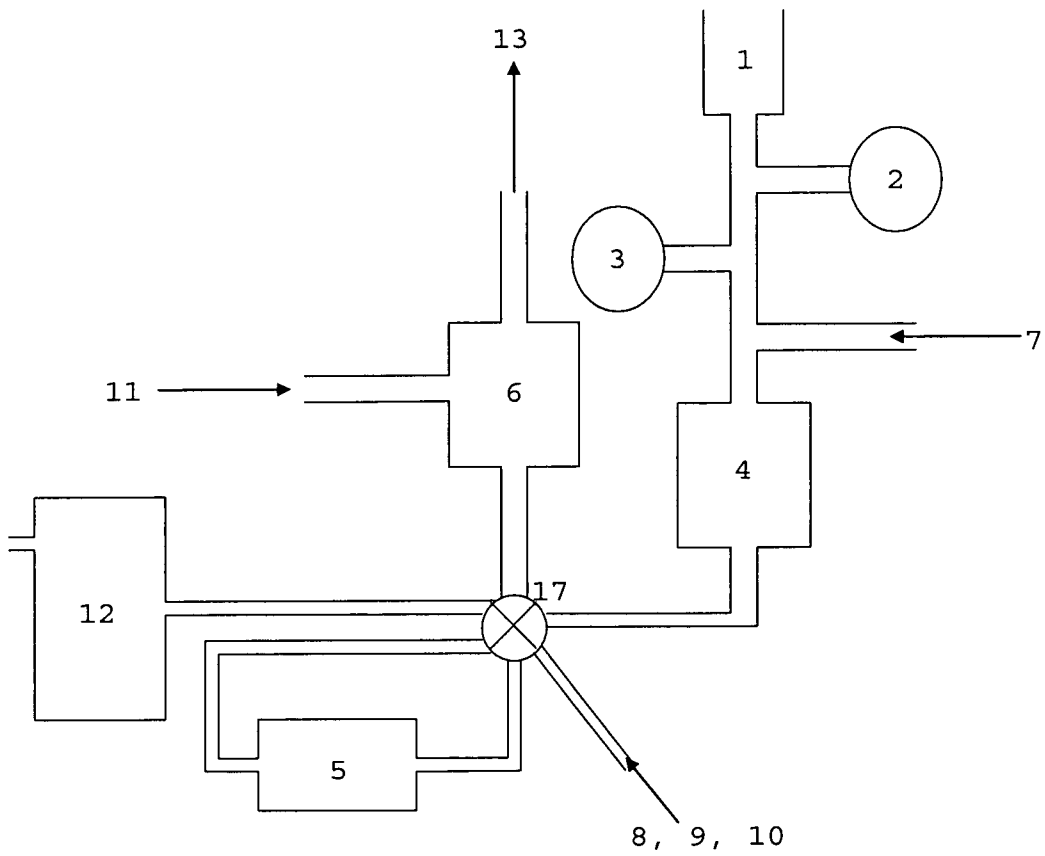

Figure 2

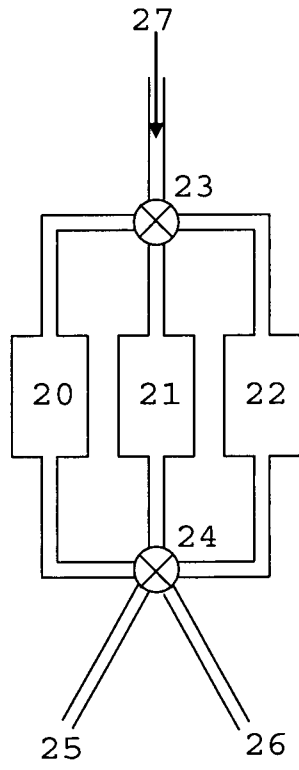

Figure 3

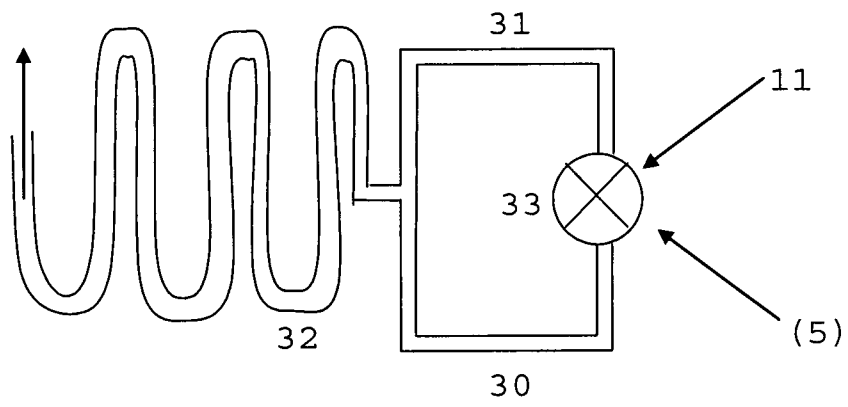

Figure 4

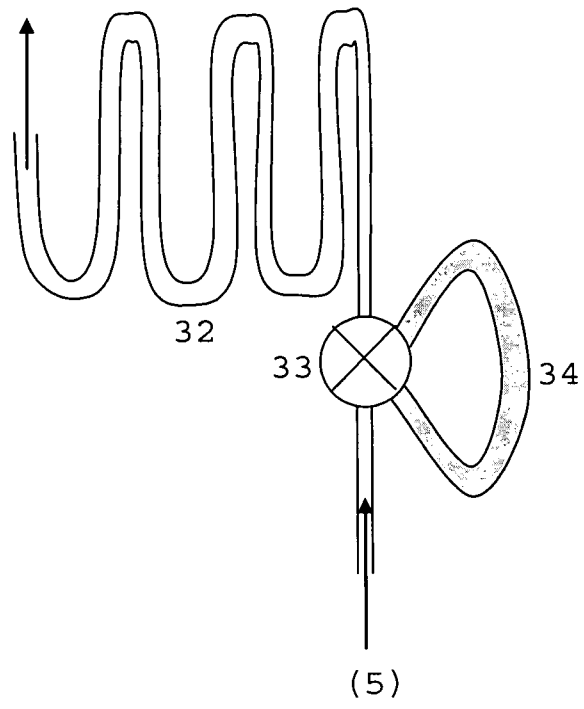

Figure 5

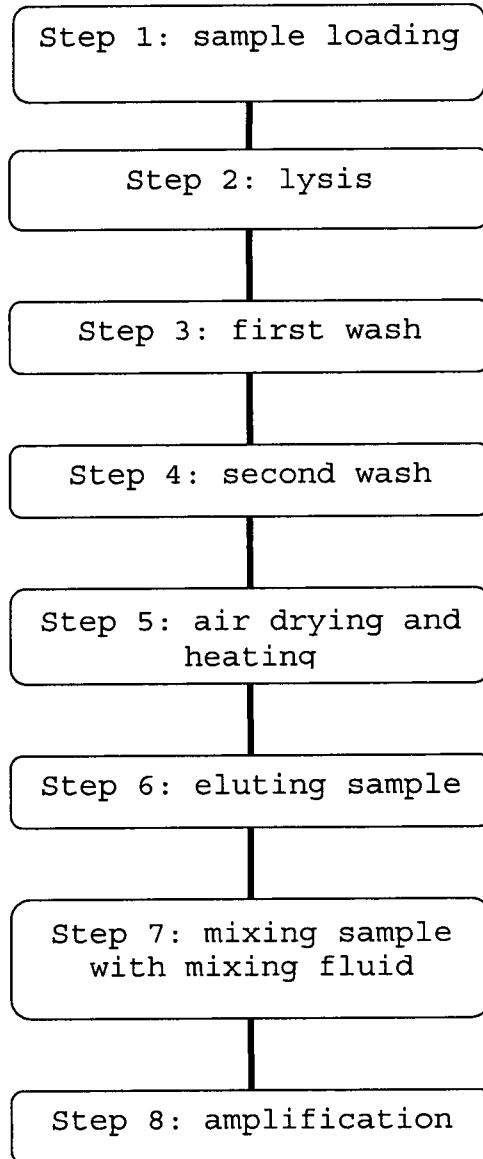

Figure 6

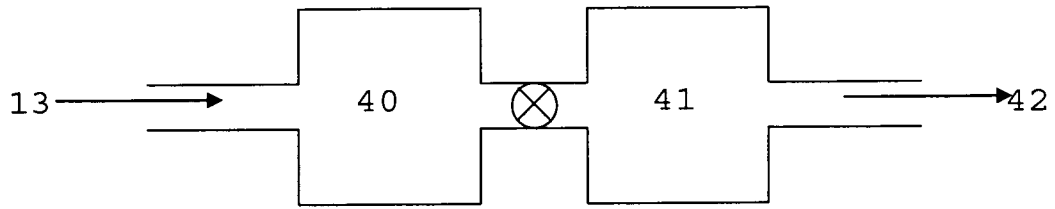

Figure 7

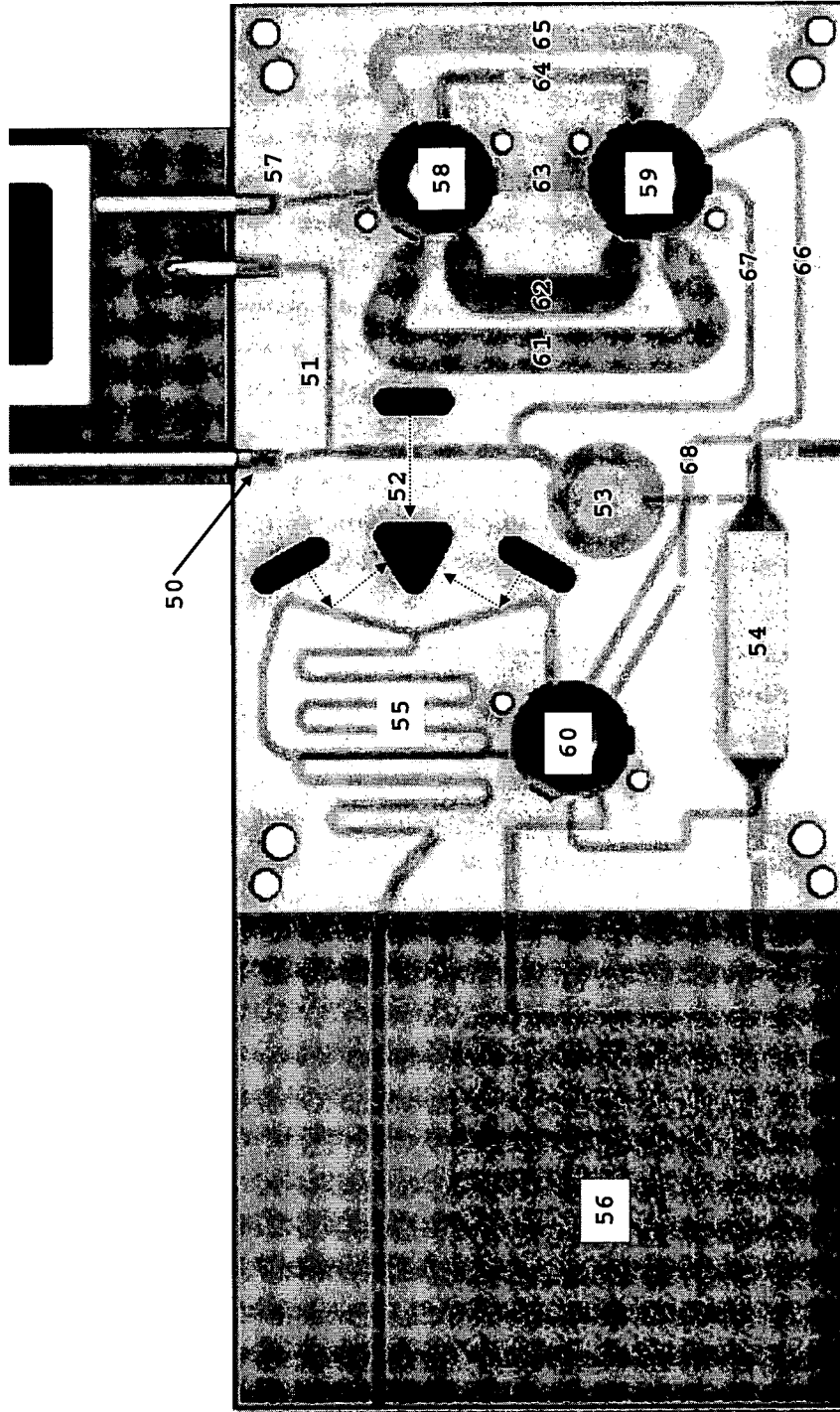

Figure 8

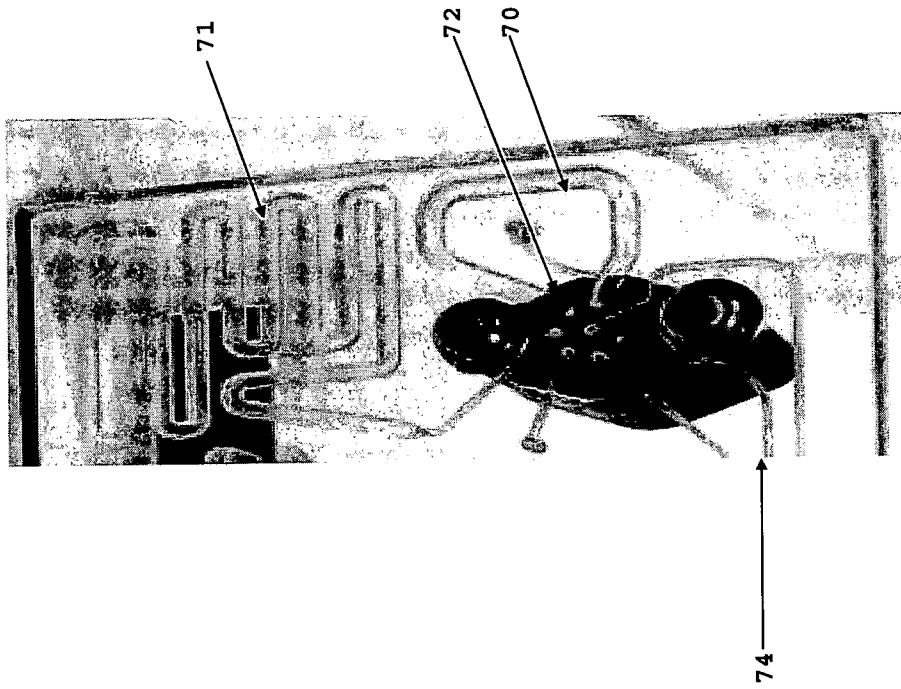

Figure 9

INTERNATIONAL SEARCH REPORT

International application No
PCT/GB2008/001956

A. CLASSIFICATION OF SUBJECT MATTER
INV. B01L3/00

According to International Patent Classification (IPC) or to both national classification and IPC

B. FIELDS SEARCHED

Minimum documentation searched (classification system followed by classification symbols)
B01L B01J C12M

Documentation searched other than minimum documentation to the extent that such documents are included in the fields searched

Electronic data base consulted during the international search (name of data base and, where practical, search terms used)
EPO-Internal, WPI Data

C. DOCUMENTS CONSIDERED TO BE RELEVANT

Category*	Citation of document, with indication, where appropriate, of the relevant passages	Relevant to claim No.
P, X	WO 2008/055257 A (VECTRANT TECHNOLOGIES INC [US]; WITTY THOMAS R [US]; WOBKEN MARK E [US]) 8 May 2008 (2008-05-08) paragraph [0006] paragraph [0052] - paragraph [0057] paragraph [0062] - paragraph [0069]	1-4, 6-9, 12, 15-19
X	WO 2006/121997 A (IDAHO TECHNOLOGY INC [US]; RIRIE KRIK M [US]; RASMUSSEN RANDY P [US];) 16 November 2006 (2006-11-16) paragraph [0037] - paragraph [0046]; figures 1, 3	1-9, 11-19

Further documents are listed in the continuation of Box C.

See patent family annex.

* Special categories of cited documents :

- *A* document defining the general state of the art which is not considered to be of particular relevance
- *E* earlier document but published on or after the international filing date
- *L* document which may throw doubts on priority claim(s) or which is cited to establish the publication date of another citation or other special reason (as specified)
- *O* document referring to an oral disclosure, use, exhibition or other means
- *P* document published prior to the international filing date but later than the priority date claimed

- *T* later document published after the international filing date or priority date and not in conflict with the application but cited to understand the principle or theory underlying the invention
- *X* document of particular relevance; the claimed invention cannot be considered novel or cannot be considered to involve an inventive step when the document is taken alone
- *Y* document of particular relevance; the claimed invention cannot be considered to involve an inventive step when the document is combined with one or more other such documents, such combination being obvious to a person skilled in the art.
- *8* document member of the same patent family

Date of the actual completion of the international search

8 August 2008

Date of mailing of the International search report

26/08/2008

Name and mailing address of the ISA/

European Patent Office, P.B. 5818 Patentlaan 2
 NL - 2280 HV Rijswijk
 Tel. (+31-70) 340-2040, Tx. 31 651 epo nl,
 Fax: (+31-70) 340-3016

Authorized officer

Marti, Pedro

INTERNATIONAL SEARCH REPORT

International application No

PCT/GB2008/001956

C(Continuation). DOCUMENTS CONSIDERED TO BE RELEVANT		
Category*	Citation of document, with indication, where appropriate, of the relevant passages	Relevant to claim No.
X	US 2005/053952 A1 (HONG JONG WOOK [US] ET AL) 10 March 2005 (2005-03-10) paragraph [0008] - paragraph [0016] paragraph [0169] paragraph [0268] - paragraph [0293]; figure 29a	1-4, 15-19
X	US 6 403 367 B1 (CHENG JING [CN] ET AL) 11 June 2002 (2002-06-11) column 5, line 21 - line 26 column 11, line 44 - column 12, line 32; figure 7	1,3,6, 15-19
X	WO 2005/073691 A (NORCHIP [NO]; SCHONFELD FRIEDHELM [DE]; VON GERMAR FRITHJOF [DE]; KARL) 11 August 2005 (2005-08-11) cited in the application page 28, line 4 - page 14, line 6 page 28, line 31 - page 35, line 5	1,2,5,6, 16-19
X	US 2004/151629 A1 (PEASE GRANT [US] ET AL) 5 August 2004 (2004-08-05) paragraph [0095] - paragraph [0110] paragraph [0139]; figures 17-22	1,2,10, 13,16-19
X	US 2005/142565 A1 (SAMPER VICTOR [SG] ET AL) 30 June 2005 (2005-06-30) paragraph [0038] - paragraph [0045] paragraph [0049] - paragraph [0051]	1,10,13, 16-19
X	WO 2004/009849 A (ISIS PHARMACEUTICALS INC [US]; ECKER DAVID J [US]; HOFSTADLER STEVEN A) 29 January 2004 (2004-01-29) examples 1,2	1,16-19
X	US 2003/138819 A1 (GONG HAIQING [SG] ET AL) 24 July 2003 (2003-07-24) paragraph [0079] - paragraph [0104]; figure 1	1,16-19
A	US 2003/186295 A1 (COLIN BRUNO [FR] ET AL) 2 October 2003 (2003-10-02) the whole document	1-19

INTERNATIONAL SEARCH REPORT

International application No.
PCT/GB2008/001956

Box No. II Observations where certain claims were found unsearchable (Continuation of item 2 of first sheet)

This international search report has not been established in respect of certain claims under Article 17(2)(a) for the following reasons:

1. Claims Nos.:
because they relate to subject matter not required to be searched by this Authority, namely:

2. Claims Nos.:
because they relate to parts of the international application that do not comply with the prescribed requirements to such an extent that no meaningful international search can be carried out, specifically:

3. Claims Nos.:
because they are dependent claims and are not drafted in accordance with the second and third sentences of Rule 6.4(a).

Box No. III Observations where unity of invention is lacking (Continuation of item 3 of first sheet)

This International Searching Authority found multiple inventions in this international application, as follows:

see additional sheet

1. As all required additional search fees were timely paid by the applicant, this international search report covers allsearchable claims.
2. As all searchable claims could be searched without effort justifying an additional fees, this Authority did not invite payment of additional fees.
3. As only some of the required additional search fees were timely paid by the applicant, this international search report covers only those claims for which fees were paid, specifically claims Nos.:

4. No required additional search fees were timely paid by the applicant. Consequently, this international search report is restricted to the invention first mentioned in the claims; it is covered by claims Nos.:

Remark on Protest

- The additional search fees were accompanied by the applicant's protest and, where applicable, the payment of a protest fee.
- The additional search fees were accompanied by the applicant's protest but the applicable protest fee was not paid within the time limit specified in the invitation.
- No protest accompanied the payment of additional search fees.

FURTHER INFORMATION CONTINUED FROM PCT/ISA/ 210

This International Searching Authority found multiple (groups of) inventions in this international application, as follows:

1. claims: 1-14,16-19

Claims 1-14: Integrated lab-on-a-chip device for carrying out a nucleic acid extraction process on a fluid sample containing cells and/or particles comprising: a sample inlet, a lysis unit, a reservoir of lysis fluid, a nucleic acid extraction unit, reservoirs of first washing buffer and eluant fluid, a mixing unit downstream of the nucleic acid extraction unit, and a source of mixing fluid.

Claims 16-17: Integrated lab-on-a-chip diagnostic system for carrying out nucleic acid extraction and a nucleic acid sequence amplification and detection process on a fluid sample containing cells and/or particles, the system comprising a nucleic acid extraction device according to any one of claims 1 to 15.

Claims 18 and 19: Methods of carrying out a nucleic acid extraction process on a fluid sample containing cells and/or particles using an integrated lab-on-a-chip device, comprising the step of providing an integrated lab-on-chip device comprising a sample inlet, a lysis unit, a nucleic acid extraction unit, a mixing unit, and reservoirs of lysis fluid, first washing buffer, eluant fluid and mixing fluid.

2. claim: 15

Integrated lab-on-a-chip device for carrying out a nucleic acid extraction process on a fluid sample containing cells and/or particles comprising a sample inlet, a lysis unit, a reservoir of lysis fluid, a nucleic acid extraction unit downstream of the lysis unit, reservoirs of first washing buffer and eluant fluid, wherein the reservoirs of lysis fluid, first washing buffer and eluant fluid are arranged in parallel, each reservoir having an upper end and a lower end, wherein the device further comprises an upper variable-position valve connected to the upper ends of the reservoirs of lysis fluid, first washing buffer and eluant fluid, a pump connected to the upper variable-position valve, a lower variable-position valve connected to the lower ends of the at least three fluid reservoirs, a first actuation channel connecting the lower variable-position valve to the lysis unit, and a second actuation channel connecting the lower variable-position valve to the nucleic acid extraction unit.

INTERNATIONAL SEARCH REPORT

Information on patent family members

International application No

PCT/GB2008/001956

Patent document cited in search report		Publication date	Patent family member(s)	Publication date
WO 2008055257	A	08-05-2008	US 2008153096 A1	26-06-2008
WO 2006121997	A	16-11-2006	AU 2006244187 A1	16-11-2006
			CA 2607661 A1	16-11-2006
			EP 1920070 A2	14-05-2008
US 2005053952	A1	10-03-2005	AU 2003299541 A1	25-05-2004
			EP 1546412 A2	29-06-2005
			JP 2006517095 T	20-07-2006
			WO 2004040001 A2	13-05-2004
US 6403367	B1	11-06-2002	NONE	
WO 2005073691	A	11-08-2005	AU 2005208085 A1	11-08-2005
			BR PI0507200 A	12-06-2007
			CA 2554452 A1	11-08-2005
			CN 1973197 A	30-05-2007
			EP 1714134 A1	25-10-2006
			GB 2416030 A	11-01-2006
			JP 2007519917 T	19-07-2007
			KR 20070027507 A	09-03-2007
US 2004151629	A1	05-08-2004	AU 2004210166 A1	19-08-2004
			CA 2515036 A1	19-08-2004
			CN 1767898 A	03-05-2006
			EP 1587626 A1	26-10-2005
			JP 2006517024 T	13-07-2006
			KR 20050106408 A	09-11-2005
			MX PA05008119 A	30-09-2005
			US 2008164155 A1	10-07-2008
			WO 2004069412 A1	19-08-2004
US 2005142565	A1	30-06-2005	EP 1704232 A1	27-09-2006
			WO 2005066343 A1	21-07-2005
			JP 2007534313 T	29-11-2007
WO 2004009849	A	29-01-2004	AU 2003254093 A1	09-02-2004
US 2003138819	A1	24-07-2003	AU 2002339833 A1	06-05-2003
			EP 1461454 A2	29-09-2004
			WO 03035909 A2	01-05-2003
US 2003186295	A1	02-10-2003	AT 396357 T	15-06-2008
			AU 8601201 A	13-03-2002
			EP 1313973 A1	28-05-2003
			FR 2813207 A1	01-03-2002
			WO 0218823 A1	07-03-2002
			JP 2004507750 T	11-03-2004