



HU000033538T2

(19) **HU**(11) Lajstromszám: **E 033 538**(13) **T2****MAGYARORSZÁG**
Szellemi Tulajdon Nemzeti Hivatala**EURÓPAI SZABADALOM**
SZÖVEGÉNEK FORDÍTÁSA(21) Magyar ügyszám: **E 09 785289**
(22) A bejelentés napja: **2009. 07. 09.**(51) Int. Cl.: **B01L 9/00** (2006.01)
G06K 7/00 (2006.01)(96) Az európai bejelentés bejelentési száma:
EP 20090785289(86) A nemzetközi (PCT) bejelentési szám:
PCT/GB 09/050810(97) Az európai bejelentés közzétételi adatai:
EP 2307143 A1 **2010. 01. 14.**(87) A nemzetközi közzétételi szám:
WO 10004331(97) Az európai szabadalom megadásának meghirdetési adatai:
EP 2307143 B1 **2017. 05. 24.**(30) Elsőbbségi adatok:
0812540 **2008. 07. 09.** **GB**(73) Jogosult(ak):
Raymond A Lamb Limited, Runcorn Cheshire
(GB)(72) Feltaláló(k):
HUGHES, Thomas Fergus, Netherfield TN33 9QL (GB)(74) Képviselő:
Gödölle, Kékes, Mészáros & Szabó
Szabadalmi és Védjegy Iroda, Budapest(54) **Laboratóriumi minta archiváló berendezés és eljárás**

Az európai szabadalom ellen, megadásának az Európai Szabadalmi Közlönyben való meghirdetésétől számított kilenc hónapon belül, felszólalást lehet benyújtani az Európai Szabadalmi Hivatalnál. (Európai Szabadalmi Egyezmény 99. cikk(1))

A fordítást a szabadalmat az 1995. évi XXXIII. törvény 84/H. §-a szerint nyújtotta be. A fordítás tartalmi helyességét a Szellemi Tulajdon Nemzeti Hivatala nem vizsgálta.

(19)



(11)

EP 2 307 143 B1

(12)

EUROPEAN PATENT SPECIFICATION

(45) Date of publication and mention of the grant of the patent:
24.05.2017 Bulletin 2017/21

(51) Int Cl.:
B01L 9/00 (2006.01) G06K 7/00 (2006.01)

(21) Application number: **09785289.1**

(86) International application number:
PCT/GB2009/050810

(22) Date of filing: **09.07.2009**

(87) International publication number:
WO 2010/004331 (14.01.2010 Gazette 2010/02)

(54) **LABORATORY SAMPLE ARCHIVING APPARATUS AND METHOD**

LABORPROBENABLEGEVORRICHTUNG UND -VERFAHREN

APPAREIL ET PROCÉDÉ D ARCHIVAGE D ÉCHANTILLONS DE LABORATOIRE

(84) Designated Contracting States:
AT BE BG CH CY CZ DE DK EE ES FI FR GB GR HR HU IE IS IT LI LT LU LV MC MK MT NL NO PL PT RO SE SI SK SM TR

(72) Inventor: **HUGHES, Thomas Fergus**
Netherfield TN33 9QL (GB)

(30) Priority: **09.07.2008 GB 0812540**

(74) Representative: **Johnstone, Douglas Ian et al**
Baron Warren Redfern
1000 Great West Road
Brentford TW8 9DW (GB)

(43) Date of publication of application:
13.04.2011 Bulletin 2011/15

(56) References cited:
WO-A-00/16280 WO-A-2004/006051
US-A- 5 287 414 US-A1- 2006 022 827

(73) Proprietor: **Raymond A Lamb Limited**
Lottbridge Drove
Eastbourne
East Sussex BN23 6QE (GB)

EP 2 307 143 B1

Note: Within nine months of the publication of the mention of the grant of the European patent in the European Patent Bulletin, any person may give notice to the European Patent Office of opposition to that patent, in accordance with the Implementing Regulations. Notice of opposition shall not be deemed to have been filed until the opposition fee has been paid. (Art. 99(1) European Patent Convention).

Description

[0001] The present invention relates to an apparatus and a method for archiving laboratory samples.

[0002] Laboratory samples are customarily stored by being mounted on slides or accommodated in so-called cassettes or other receptacles. For simplicity, reference below has simply been made to slides. The slides are customarily accommodated drawers which are translatable in and out of cabinets holding plural rows and columns of drawers. A laboratory may keep thousands of slides and need to maintain a record of the whereabouts of the slides for many years during which the slides may be taken in and out of the cabinets. Maintaining accurate records concerning which slides are in the cabinets at any one time and when they were taken in and out of the cabinets is a time consuming task and prone to human error. If a conventional radio frequency identification (RFID) reader is used to assist in the archiving process the closeness of the slides to each other in a typical laboratory cabinet drawer causes problems with an RFID signal from one slide being masked or shadowed by radio RFID tags of adjacent slides. The conventional reader may also pick-up signals from RFID tags of adjacent slides which it is not intended to pick-up.

[0003] WO 2004/006051, on which the preamble of claim 1 is based, discloses a system for tracking objects of evidence wherein each object includes a transponder. The system includes a cabinet containing drawers and each drawer is translatable in a translation direction into and out of the cabinet. Antennae in the cabinet are spaced above each drawer when it is closed to divide the area of the drawer into sectors and the antennae are connected to a server via scanners. When an object of evidence is placed in a drawer and the drawer is closed, the system can determine from the relevant antenna which sector of which drawer the object of evidence is located.

[0004] WO 00/16280 discloses a system for tracking file folders wherein each file folder includes an RFID tag. The system includes a filing cabinet containing a plurality of drawers wherein the file folders have hooked ends to enable them to hang in the drawers. At the back of each drawer is an inductive loop antenna which is connected to a controller. The controller sequentially polls the antennae which cause the RFID tags of the file folders in the corresponding drawers to be activated and the controller can then determine which files are in which drawers.

[0005] An object of the invention is to provide an archiving apparatus and method which at least partly overcome the problems referred to above.

[0006] Thus according to a first aspect of the invention there is provided an archive apparatus for storing and archiving items including radio frequency identification means the apparatus comprising a support structure, a drawer translatable in a translation direction into and out of the support structure, item support means associated

with the drawer, a radio frequency reader antenna connected to the support structure adjacent to the drawer and recording means adapted to operatively communicate with the reader antenna to store information obtained from the radio frequency identification means of items supported by the drawer, characterized in that said items are laboratory samples; the item support means is a sample support means for supporting an array of said laboratory samples spaced at a pitch along the translation direction for movement with the drawer; and the reader antenna is configured to emit a curtain of electromagnetic waves which has a maximum dimension in the translation direction which is less than the pitch of the laboratory samples whereby the reader antenna will only read one radio frequency identification means at any one time as the drawer is translated between its opened and closed positions. With such an apparatus, because the reader antenna is connected to the support structure adjacent to the drawer it can be positioned in an optimum manner relative to samples or slides to eliminate the problem of masking referred to above. Furthermore the operative communication between the reader antenna and the recording means permits the information from the radio frequency identification means to be stored by the recording means without human intervention thus cutting out human error and the significant time involved in prior art archiving systems. The drawer can enable the samples to be orientated so that they can be read easily by the reader antenna. With an arrangement of the reader antenna being configured to emit a curtain of electromagnetic waves, the reader antenna can be arranged to communicate with the radio frequency identification means associated with a limited number of slides or samples. If RFID tags of the slides are so-called passive RFID tags then they will only emit a signal upon receipt of a signal from the reader antenna.

[0007] Preferably the recording means includes a control means operatively connected to the reader antenna and a single control means may advantageously be operatively connected to plural reader antennae connected to the same support structure.

[0008] In order to provide a system which can automatically track movements of slides into and out of the support structure preferably the control means is operatively connected to a computer system including sample tracking software. The tracking software may comprise software such as the tracking software marketed under the name LambTrack.

[0009] Since laboratories often accommodate many drawers of slides, preferably the support structure accommodates plural drawers and more preferably one said reader antenna is connected to the support structure adjacent to each drawer.

[0010] When the support structure accommodates plural drawers each with an associated reader antenna the control means is preferably operatively connected to plural said reader antennae.

[0011] The apparatus may not be limited to a single

support structure and may advantageously comprise a compound archive apparatus including plural archive apparatuses as described above. In such a compound archive apparatus the recording means preferably includes a single computer system operatively connected to the reader antennae. In this manner a single system can be used to track the movements of slides into and out of all support structures in a given laboratory or possibly in several laboratories between which the slides may be transferred for various operations.

[0012] According to a second aspect of the invention there is provided a method for storing and archiving laboratory samples with radio frequency identification means including providing apparatus comprising a support structure, a drawer translatable in a translation direction into and out of the support structure, supporting the laboratory samples in an array in sample support means associated with the drawer with the laboratory samples spaced at a pitch along the translation direction for movement with the drawer, providing a radio frequency reader antenna connected to the support structure adjacent to the drawer and recording means, translating the drawer in the translation direction so that the laboratory samples pass through a curtain of electromagnetic waves emitted by the reader antenna wherein the curtain has a maximum dimension in the translation direction which is less than the pitch of the laboratory samples whereby the reader antenna will only read one radio frequency identification means at any one time as the drawer is translated between its opened and closed positions, operatively communicating information from the radio frequency identification means of the samples supported by the drawer to the recording means and recording said information with the recording means.

[0013] The method preferably also comprises the further steps of at least partly translating the drawer out of the support structure, altering a distribution of the samples supported by the drawer, translating the drawer back into the support structure and updating a record held by the recording means of samples supported by the drawer based on signals received by the reader antenna.

[0014] In order that the method not only records information concerning the slides currently in the drawer the method preferably also records historic information concerning the samples in the drawer in addition to current information concerning the samples in the drawer.

[0015] To assist in the interpretation of the information held by the recording means, preferably the stored information concerning samples supported by the drawer is displayed by the recording means graphically. Alternatively the information could be displayed as text or as a combination of text and graphic representations.

[0016] The invention will now be described by way of example only with reference to the accompanying schematic drawings in which:

Figure 1 shows a partial perspective view of a support structure of the archive apparatus according to

the invention;

Figure 2 shows a side view of a part of the support structure shown in Figure 1 with a drawer pulled out;

Figure 3 shows a detailed partial side view, partly broken away, of the part of the support structure shown in Figure 2; and

Figure 4 shows the interconnections between plural support structures and associated controllers and a central computer.

[0017] Referring to Figure 1 the support structure (hereinafter referred to as a cabinet 4) supports plural drawers 6 which are translatable in a translation direction 12 into and out of the cabinet 4. Although the term drawer has been used, there is no requirement for the drawer to even partly enclose a volume in which the slides are accommodated. It is merely necessary for it to be possible to draw the drawer at least partly out of the cabinet and for the drawer to support an array 10 of slides 20 by means of slide support means 8. The left hand drawer shown in Fig. 1 is empty and is pulled out of the cabinet 4 so as to show the slide support means which comprises vertical ribs 8 which project inwardly from inner surfaces 24 of confronting side walls 26 of the drawers 6. These ribs 8 are shown more clearly in the partially cut-away view of a drawer 6 shown in Fig. 3 and are spaced such that gaps 30 between them snugly accommodate a slide 20. The slides 20 are supported vertically with a relatively close pitch or centre spacing distance X as shown in Fig. 3. The distance X may conveniently be slightly more than the thickness of a slide.

[0018] As shown most clearly in Figure 3, a radio frequency reader antenna 14 is mounted immediately above each drawer opening 28 in a front face 32 of the cabinet 4. Each reader antenna 14 is specially designed and configured to provide a curtain 18 of electromagnetic waves which can be used to power up the RFID tag 2 mounted on each slide 20. This may be achieved by the deployment of a shield close to the reader antenna with a slot formed therein to limit the extent to which electromagnetic waves emitted by the reader antenna spread out as they travel away from the reader antenna. With a slide mounted in the drawer with its RFID tag 2 positioned uppermost as shown, where the curtain of electromagnetic waves 18 has a maximum dimension in the translation direction of a distance Y which is less than the pitch X of the slides in order that the reader antenna will only read one RFID tag at any one time as the drawer is translated between its opened and closed positions.

[0019] As shown in Figure 4, each reader antenna 14 is operatively connected, for example by a wire, to a controller. The connection may alternatively be by some non-wired means. The controller 34 may be provided with a signal from a drawer actuated switch (one only shown in Fig. 4) and actuate the appropriate reader antenna 14

upon sensing that a drawer opening activity has been commenced. Preferably a single controller 34 is mounted in each cabinet and controls the actuation of all of the reader antennae in that cabinet. The controller 34 may alternatively be connected to, rather than mounted within, the cabinet 4.

[0020] As a drawer 6 is progressively opened the reader antenna 14 over that drawer reads the RFID tag of each slide as it passes through the curtain 18 of electromagnetic radiation emitted by the reader antenna 14. Information from the RFID tag is routed by the controller 34 to a central computer 38 in which tracking software logs the information. When required this information can be supplied by the central computer and may be supplied in a graphic and/or text format which makes it readily apparent which slides are accommodated in each drawer and in what position in the drawer the slide is located. A graphical view of the physical storage units and their contents may be displayed. The controller may alternatively store the relevant information locally and not be connected to a central computer. In this case the controller would be interrogatable so as to provide information concerning the slides in the cabinet and also possibly historic information concerning slides in the cabinet.

[0021] The controller 34 may be configured to maintain an actuated reader antenna 14 in an active state until the associated drawer is closed as sensed by the associated switch 36 or for a certain period of time after actuation. The reader antenna 14 provides information to the central computer 38 via the controller 34 as the drawer is closed so that the tracking software can be updated to take account of any changes to the slides in the drawer by removal, addition or moving.

[0022] The support structure or cabinet 4 may also be provided with a reader 40 suitable for reading an identification badge 42 or other identification means of a user. Information relating to the user may be stored by the controller 34 and/or central computer 38 together with information concerning the samples 20 added to or removed from a particular drawer 6. The support structure could also be adapted to only unlock a particular support structure/drawer for a user who has been assigned appropriate authority. The user identification badge 42 could include information concerning such authority.

[0023] Various modifications to the apparatus and method, which would be obvious to a skilled person in the art, may be made without departing from the scope of the invention as defined in the following claims.

Claims

1. Archive apparatus for storing and archiving items (20) including radio frequency identification means (2) the apparatus comprising a support structure (4), a drawer (6) translatable in a translation direction (12) into and out of the support structure (4), item support means (8) associated with the drawer (6), a

radio frequency reader antenna (14) connected to the support structure (4) adjacent to the drawer (6) and recording means (34, 38) adapted to operatively communicate with the reader antenna (14) to store information obtained from the radio frequency identification means of items (20) supported by the drawer (6), **characterized in that**

said items are laboratory samples (20);

the item support means (8) is a sample support means for supporting an array (10) of said laboratory samples (20) spaced at a pitch (X) along the translation direction (12) for movement with the drawer (6); and

the reader antenna (14) is configured to emit a curtain (18) of electromagnetic waves which has a maximum dimension (Y) in the translation direction which is less than the pitch (X) of the laboratory samples (20) whereby the reader antenna (14) will only read one radio frequency identification means (2) at any one time as the drawer (6) is translated between its opened and closed positions.

2. The apparatus according to claim 1, wherein the recording means (34, 38) includes a control means (34) operatively connected to the reader antenna (14).
3. The apparatus according to claim 2, wherein the control means (34) is operatively connected to a computer system (38) including sample tracking software.
4. The apparatus according to claim 1, 2 or 3, wherein the support structure (4) accommodates plural drawers (6).
5. The apparatus according to claim 4, wherein one said reader antenna (14) is connected to the support structure (4) adjacent to each drawer (6).
6. The apparatus according to claims 2 and 5, wherein the control means (34) is operatively connected to plural said reader antennae (14).
7. Compound archive apparatus comprising plural archive apparatuses according to any preceding claim.
8. The compound archive apparatus according to claim 7, wherein the recording means (34, 38) includes a single computer system (38) operatively connected to the reader antennae (14).
9. A method for storing and archiving laboratory samples (20) with radio frequency identification means (2) including providing apparatus comprising a support structure (4), a drawer (6) translatable in a trans-

lation direction (12) into and out of the support structure (4), supporting the laboratory samples (20) in an array (10) in sample support means (8) associated with the drawer (6) with the laboratory samples (20) spaced at a pitch (X) along the translation direction (12) for movement with the drawer (6), providing a radio frequency reader antenna (14) connected to the support structure (4) adjacent to the drawer (6) and recording means (34, 38), translating the drawer (6) in the translation direction (12) so that the laboratory samples (20) pass through a curtain (18) of electromagnetic waves emitted by the reader antenna (14) wherein the curtain (18) has a maximum dimension (Y) in the translation direction which is less than the pitch (X) of the laboratory samples (20) whereby the reader antenna (14) will only read one radio frequency identification means (2) at any one time as the drawer (6) is translated between its opened and closed positions, operatively communicating information from the radio frequency identification means (2) of the samples (20) supported by the drawer (6) to the recording means (34, 38) and recording said information with the recording means (34, 38).

10. The method according to claim 9, comprising the further steps of at least partly translating the drawer (6) out of the support structure (4), altering a distribution of the samples supported by the drawer (6), translating the drawer (6) back into the support structure (4) and updating a record held by the recording means (34, 38) of samples (20) supported by the drawer (6) based on signals received by the reader antenna (14).
11. The method according to claim 9 or 10, wherein the recording means (34, 38) records historic information concerning the samples (20) in the drawer (6) in addition to current information concerning the samples (20) in the drawer (6).
12. The method according to claim 9, 10 or 11, wherein the stored information concerning samples (20) supported by the drawer (6) is displayed by the recording means (34, 38) graphically.
13. The method according to any of claims 9 to 12, including identifying a user accessing the samples (20) by means of user identification means (42) and using this identification to record which user has accessed the samples (20) or to control access to the samples (20).

Patentansprüche

1. Archivierungsvorrichtung zum Aufbewahren und Archivieren von Gegenständen (20), die RFID-Mittel

(2) aufweisen, wobei die Vorrichtung eine Tragstruktur (4), eine Schublade (6), die in einer Verfahrrichtung (12) in die Tragstruktur (4) hinein und aus ihr heraus verfahrbar ist, ein Gegenstandstragmittel (8), das der Schublade (6) zugeordnet ist, eine RFID-Leserantenne (14), die benachbart zu der Schublade (6) mit der Tragstruktur (4) verbunden ist, und ein Aufzeichnungsmittel (34, 38) umfasst, das dazu angepasst ist, mit der Leserantenne (14) wirksam zu kommunizieren, um Informationen zu speichern, die von den RFID-Mitteln von Gegenständen (20) erhalten wurden, die von der Schublade (6) getragen werden, **dadurch gekennzeichnet, dass**

- die Gegenstände Laborproben (20) sind; das Gegenstandstragmittel (8) ein Proben-tragmittel zum Tragen einer Anordnung (10) der Laborproben (20) ist, die zur Bewegung mit der Schublade (6) in einem Abstand (X) entlang der Verfahrrichtung (12) beabstandet sind; und die Leserantenne (14) dazu konfiguriert ist, einen Vorhang (18) elektromagnetischer Wellen abzugeben, der eine maximale Abmessung (Y) in der Verfahrrichtung hat, die kleiner als der Abstand (X) der Laborproben (20) ist, wodurch die Leserantenne (14) nur ein RFID-Mittel (2) zu einer bestimmten Zeit liest, während die Schublade (6) zwischen ihrer offenen und geschlossenen Position verfahren wird.
2. Vorrichtung gemäß Anspruch 1, wobei das Aufzeichnungsmittel (34, 38) ein Steuerungsmittel (34) aufweist, das mit der Leserantenne (14) wirksam verbunden ist.
3. Vorrichtung gemäß Anspruch 2, wobei das Steuerungsmittel (34) mit einem Computersystem (38) wirksam verbunden ist, das eine Probennachverfolgungssoftware enthält.
4. Vorrichtung gemäß Anspruch 1, 2 oder 3, wobei in der Tragstruktur (4) mehrere Schubladen (6) untergebracht sind.
5. Vorrichtung gemäß Anspruch 4, wobei eine solche Leserantenne (14) benachbart zu jeder Schublade (6) mit der Tragstruktur (4) verbunden ist.
6. Vorrichtung gemäß einem der Ansprüche 2 und 5, wobei das Steuerungsmittel (34) mit mehreren solchen Leserantennen (14) wirksam verbunden ist.
7. Verbund-Archivierungsvorrichtung, die mehrere Archivierungsvorrichtungen gemäß einem der vorhergehenden Ansprüche umfasst.
8. Verbund-Archivierungsvorrichtung gemäß Anspruch 7, wobei das Aufzeichnungsmittel (34, 38)

ein einziges Computersystem (38) aufweist, das mit den Leserantennen (14) wirksam verbunden ist.

9. Verfahren zum Aufbewahren und Archivieren von Laborproben (20) mit RFID-Mitteln (2), aufweisend: Vorsehen einer Vorrichtung, die eine Tragstruktur (4), eine Schublade (6) umfasst, die in einer Verfahr- richtung (12) in die Tragstruktur (4) hinein und aus ihr heraus verfahrbar ist, welche die Laborproben (20) in einer Anordnung (10) in einem Probentrag- mittel (8) trägt, das der Schublade (6) mit den La- borproben (20) zugeordnet ist, die zur Bewegung mit der Schublade (6) in einem Abstand (X) entlang der Verfahr- richtung (12) beabstandet sind, Vorsehen einer RFID-Leserantenne (14), die benachbart zu der Schublade (6) mit der Tragstruktur (4) verbunden ist, und eines Aufzeichnungsmittels (34, 38), Verfahren der Schublade (6) in der Verfahr- richtung (12), so- dass die Laborproben (20) durch einen Vorhang (18) elektromagnetischer Wellen gelangen, die von der Leserantenne (14) abgegeben werden, wobei der Vorhang (18) eine maximale Abmessung (Y) in der Verfahr- richtung hat, die kleiner als der Abstand (X) der Laborproben (20) ist, wodurch die Leserantenne (14) nur ein RFID-Mittel (2) zu einer bestimmten Zeit liest, während die Schublade (6) zwischen ihrer of- fenen und geschlossenen Position verfahren wird, wirksames Kommunizieren von Informationen von den RFID-Mitteln (2) der Proben (20), die von der Schublade (6) getragen werden, zu dem Aufzeich- nungsmittel (34, 38) und Aufzeichnen der Informati- onen mit dem Aufzeichnungsmittel (34, 38).

10. Verfahren gemäß Anspruch 9, umfassend die fol- genden weiteren Schritte:

mindestens teilweise Verfahren der Schublade (6) aus der Tragstruktur (4) heraus, Ändern einer Verteilung der von der Schublade (6) getrage- nen Proben, Verfahren der Schublade (6) wie- der in die Tragstruktur (4) hinein und Aktualisie- ren einer von dem Aufzeichnungsmittel (34, 38) gehaltenen Aufzeichnung von der Schublade (6) getragener Proben (20) auf Basis von der Leserantenne (14) empfangener Signale.

11. Verfahren gemäß Anspruch 9 oder 10, wobei das Aufzeichnungsmittel (34, 38) historische Informati- onen über die Proben (20) in der Schublade (6) zu- sätzlich zu aktuellen Informationen über die Proben (20) in der Schublade (6) aufzeichnet.

12. Verfahren gemäß Anspruch 9, 10 oder 11, wobei die gespeicherten Informationen über die von der Schublade (6) getragenen Proben (20) von dem Auf- zeichnungsmittel (34, 38) graphisch angezeigt wer- den.

13. Verfahren gemäß einem der Ansprüche 9 bis 12, aufweisend Identifizieren eines auf die Proben (20) zugreifenden Benutzers mittels Benutzeridentifikati- onsmitteln (42) und Verwenden dieser Identifikation zum Aufzeichnen, welcher Benutzer auf die Proben (20) zugegriffen hat, oder zum Kontrollieren des Zu- griffs auf die Proben (20).

10 Revendications

1. Dispositif d'archivage pour stocker et archiver des articles (20) comprenant des moyens d'identification par radiofréquence (2), le dispositif comprenant une structure de support (4), un tiroir (6) déplaçable par translation dans une direction de translation (12) dans et hors de la structure de support (4), des moyens de support d'article (8) associés au tiroir (6), une antenne de lecteur de radiofréquence (14) connectée à la structure de support (4) adjacente au tiroir (6) et des moyens d'enregistrement (34, 38) adaptés pour communiquer fonctionnellement avec l'antenne de lecteur (14) pour stocker des informations obtenues à partir des moyens d'identification par radiofréquence d'articles (20) supportés par le tiroir (6), **caractérisé en ce que** lesdits articles sont des échantillons de laboratoire (20) ; les moyens de support d'article (8) sont un moyen de support d'échantillon pour supporter un réseau (10) desdits échantillons de laboratoire (20) espacés avec un pas (X) suivant la direction de translation (12) pour un mouvement avec le tiroir (6) ; et l'antenne de lecteur (14) est configurée pour émettre un rideau (18) d'ondes électromagnétiques qui a une dimension maximale (Y) dans la direction de translation qui est inférieure au pas (X) des échantillons de laboratoire (20), moyennant quoi l'antenne de lec- teur (14) lira un seul moyen d'identification par ra- diofréquence (2) à n'importe quel moment lorsque le tiroir (6) est déplacé par translation entre ses po- sitions ouverte et fermée.
2. Dispositif selon la revendication 1, dans lequel les moyens d'enregistrement (34, 38) comprennent un moyen de commande (34) connecté fonctionnelle- ment à l'antenne de lecteur (14).
3. Dispositif selon la revendication 2, dans lequel le moyen de commande (34) est connecté fonctionnel- lement à un système informatique (38) comprenant un logiciel de suivi d'échantillon.
4. Dispositif selon la revendication 1, 2 ou 3, dans le- quel la structure de support (4) loge plusieurs tiroirs (6).
5. Dispositif selon la revendication 4, dans lequel une

- dite antenne de lecteur (14) est connectée à la structure de support (4) adjacente à chaque tiroir (6).
6. Dispositif selon les revendications 2 et 5, dans lequel le moyen de commande (34) est connecté fonctionnellement à plusieurs dites antennes de lecteur (14). 5
7. Appareil d'archivage composé comprenant une pluralité de dispositifs d'archivage selon une quelconque revendication précédente. 10
8. Appareil d'archivage composé selon la revendication 7, dans lequel les moyens d'enregistrement (34, 38) comprennent un unique système informatique (38) connecté fonctionnellement aux antennes de lecteur (14). 15
9. Procédé pour stocker et archiver des échantillons de laboratoire (20) avec des moyens d'identification par radiofréquence (2), comprenant la fourniture d'un dispositif comprenant une structure de support (4), un tiroir (6) déplaçable par translation dans une direction de translation (12) dans et hors de la structure de support (4), le support des échantillons de laboratoire (20) dans un réseau (10) dans des moyens de support d'échantillons (8) associés au tiroir (6) avec les échantillons de laboratoire (20) espacés avec un pas (X) suivant la direction de translation (12) pour un mouvement avec le tiroir (6), la fourniture d'une antenne de lecteur de radiofréquence (14) connectée à la structure de support (4) adjacente au tiroir (6) et aux moyens d'enregistrement (34, 38), le déplacement par translation du tiroir (6) dans la direction de translation (12) de manière que les échantillons de laboratoire (20) passent à travers un rideau (18) d'ondes électromagnétiques émises par l'antenne de lecteur (14), dans lequel le rideau (18) a une dimension maximale (Y) dans la direction de translation qui est inférieure au pas (X) des échantillons de laboratoire (20), moyennant quoi l'antenne de lecteur (14) lira un seul moyen d'identification par radiofréquence (2) à n'importe quel moment lorsque le tiroir (6) est déplacé par translation entre ses positions ouverte et fermée, en communiquant fonctionnellement des informations des moyens d'identification par radiofréquence (2) des échantillons (20) supportés par le tiroir (6) aux moyens d'enregistrement (34, 38) et l'enregistrement desdites informations avec les moyens d'enregistrement (34, 38). 20
25
30
35
40
45
50
10. Procédé selon la revendication 9, comprenant en outre les étapes ultérieures de translation au moins partielle du tiroir (6) hors de la structure de support (4), la modification d'une distribution des échantillons supportés par le tiroir (6), la translation du tiroir (6) à nouveau dans la structure de support (4) et la mise à jour d'un enregistrement maintenu par les moyens d'enregistrement (34, 38) d'échantillons 55
- (20) supportés par le tiroir (6) sur la base de signaux reçus par l'antenne de lecteur (14).
11. Procédé selon la revendication 9 ou 10, dans lequel les moyens d'enregistrement (34, 38) enregistrent des informations historiques concernant les échantillons (20) dans le tiroir (6) en plus d'informations actuelles concernant les échantillons (20) dans le tiroir (6).
12. Procédé selon la revendication 9, 10 ou 11, dans lequel les informations stockées concernant des échantillons (20) supportés par le tiroir (6) sont affichées graphiquement par les moyens d'enregistrement (34, 38).
13. Procédé selon l'une quelconque des revendications 9 à 12, comprenant l'identification d'un utilisateur accédant aux échantillons (20) au moyen de moyens d'identification d'utilisateur (42) et l'utilisation de cette identification pour enregistrer l'utilisateur qui a accédé aux échantillons (20) ou pour contrôler l'accès aux échantillons (20).

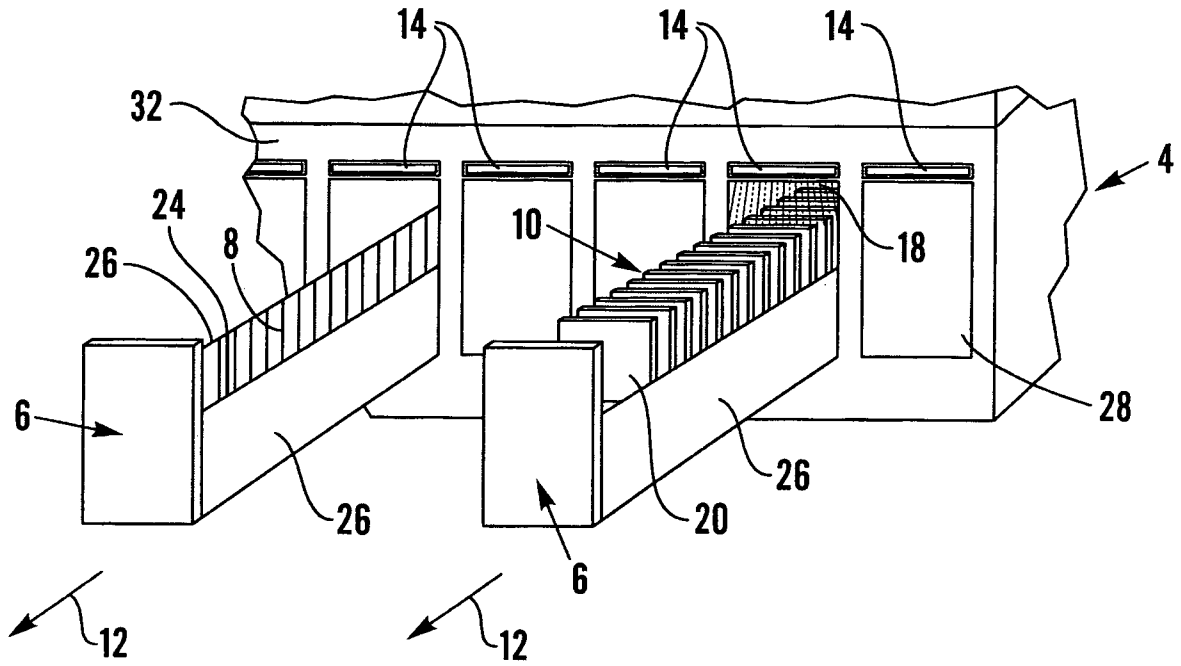

Fig. 1

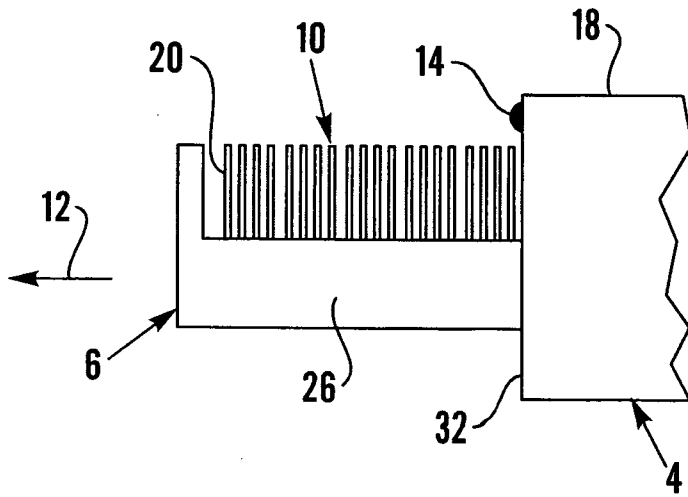

Fig. 2

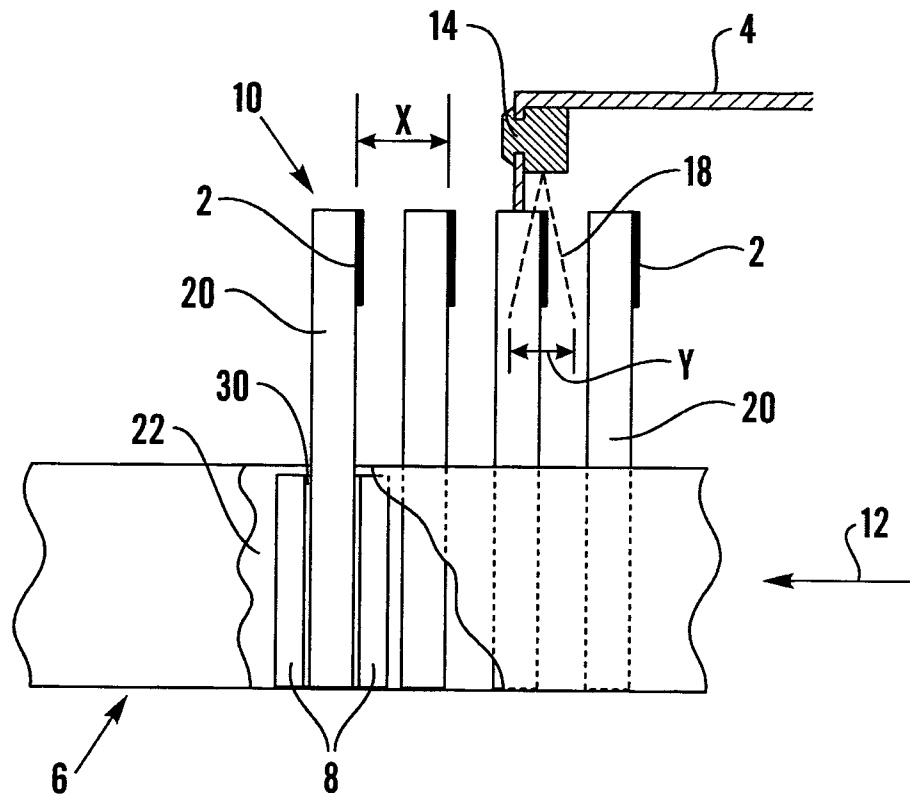

Fig.3

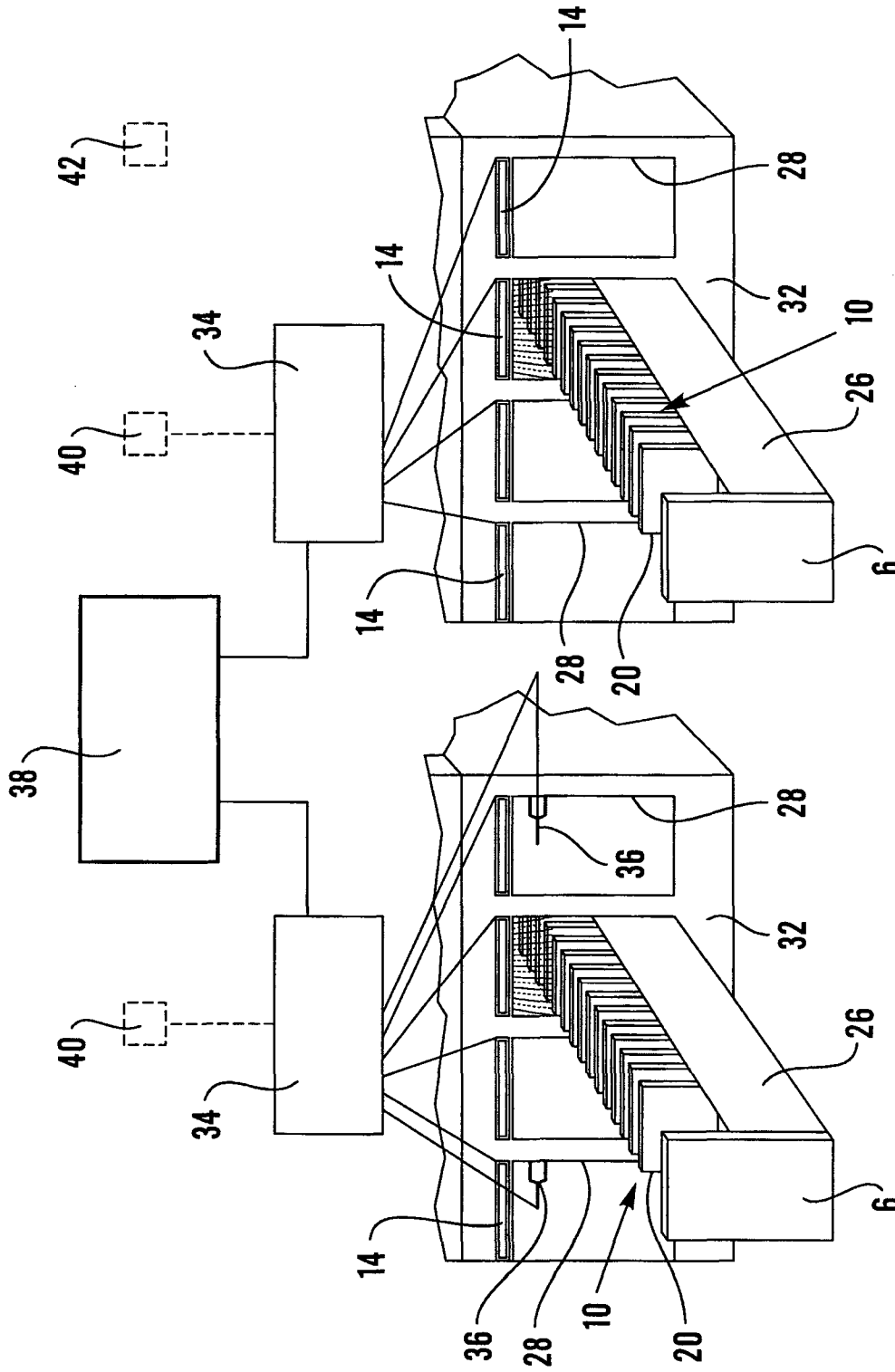

Fig.4

REFERENCES CITED IN THE DESCRIPTION

This list of references cited by the applicant is for the reader's convenience only. It does not form part of the European patent document. Even though great care has been taken in compiling the references, errors or omissions cannot be excluded and the EPO disclaims all liability in this regard.

Patent documents cited in the description

- WO 2004006051 A [0003]
- WO 0016280 A [0004]

Szabadalmi igénypontok

1. Archiváló berendezés tárgyak (20) tárolására és archiválására, amely tárgyak magukban foglalnak rádiófrekvenciás azonosító eszközt (2), a berendezés tartalmaz tartószerkezetet (4), fiókot (6), amely mozgatási irányban (12) a tartószerkezetbe (4) bemozgatható és abból kimozgatható, tárgytartó eszközt (8), amely kapcsolatban van a fiókkal (6), rádiófrekvenciás olvasó antennát (14), amely csatlakoztatva van a tartószerkezethez (4) a fiók (6) közelében, és regisztráló eszközt (34, 38), amely úgy van kialakítva, hogy funkcionálisan kommunikáljon az olvasó antennával (14), hogy tárolja a fiók (6) által tartott tárgyak (20) rádiófrekvenciás azonosító eszközeitől kapott információt, **azzal jellemezve**, hogy

a tárgyak laboratóriumi minták (20);

a tárgytartó eszköz (8) mintatartó eszköz a laboratóriumi minták (20) elrendezésének (10) tartására, amely laboratóriumi minták a fiókkal (6) való mozgatás mozgatási iránya (12) mentén térközzel (X) vannak elhelyezve; és az olvasó antenna (14) úgy van kialakítva, hogy elektromágneses hullámok függönyét (18) bocsátja ki, amelynek maximális mérete (Y) a mozgatási irányban kisebb, mint a laboratóriumi minták (20) térköze (X), ezáltal az olvasó antenna (14) csak egyetlen rádiófrekvenciás eszközt (2) olvas bármely időpontban, amikor a fiók (6) nyitott és zárt helyzete között mozgásra kerül.

2. Az 1. igénypont szerinti berendezés, amelyben a regisztráló eszköz (34, 38) tartalmaz vezérlő eszközt (34), amely funkcionálisan csatlakoztatva van az olvasó antennához (14).
3. A 2. igénypont szerinti berendezés, amelyben a vezérlő eszköz (34) funkcionálisan csatlakoztatva van mintakövető szoftvert magában foglaló számítógép rendszerhez (38).
4. Az 1., 2. vagy 3. igénypont szerinti berendezés, amelyben a tartószerkezet (4) több fiókot (6) képes befogadni.



5. A 4. igénypont szerinti berendezés, amelyben egy említett olvasó antenna (14) van csatlakoztatva a tartószerkezeihez (4) mindegyik fiók (6) közelében.
6. A 2. és 5. igénypontok szerinti berendezés, amelyben a vezérlő eszköz (34) funkcionálisan csatlakoztatva van több említett olvasó antennához (14).
7. Összetett archiváló berendezés, amely több, az előző igénypontok bármelyike szerinti archiváló berendezést tartalmaz.
8. A 7. igénypont szerinti összetett archiváló berendezés, amelyben a regisztráló eszköz (34, 38) tartalmaz egyetlen számítógépet (38), amely funkcionálisan csatlakoztatva van az olvasó antennákhoz (14).
9. Eljárás rádiófrekvenciás azonosító eszközzel (2) ellátott laboratóriumi minták (20) tárolására és archiválására, amely tartalmazza a következő lépéseket: rendelkezésre bocsátunk egy berendezést, amely tartalmaz tartószerkezetet (4), fiókot (6), amely mozgató irányban (12) a tartószerkezetbe (4) bemozgatható és abból kimozgatható, tartjuk a laboratóriumi mintákat (20) egy elrendezésben (10) egy mintatartó eszközben (8), amely kapcsolatban van a fiókkal (6), ahol a laboratóriumi minták (20) a fiókkal (6) való mozgató mozgató irány (12) mentén térköz (X) vannak elhelyezve, rendelkezésre bocsátunk egy rádiófrekvenciás olvasó antennát (14), amely csatlakoztatva van a tartószerkezetbe (4) a fiók (6) közelében, és egy regisztráló eszközt (34, 38), mozgatójuk a fiókot (6) a mozgató irányban (12) úgy, hogy a laboratóriumi minták (20) keresztülhaladjanak az olvasó antenna (14) által kibocsátott elektromágneses hullámok függőnyén (18), ahol a függőny (18) maximális mérete (Y) a mozgató irányban kisebb, mint a laboratóriumi minták (20) térköze (X), ezáltal az olvasó antenna (14) csak egyetlen rádiófrekvenciás eszközt (2) olvas bármely időpontban, amikor a fiók (6) nyitott és zárt helyzete között mozgatóra kerül, funkcionálisan kommunikáljuk a fiók (6) által tartott minták (20) rádiófrekvenciás azonosító eszközeitől (2) érkező információt a regisztráló eszközhöz (34, 38), és regisztráljuk az információt a regisztráló eszközzel (34, 38).

10. A 9. igénypont szerinti eljárás, amely tartalmazza a következő további lépéseket: legalább részben kimoszatjuk a fiókot (6) a tartószerkezetből (4), megváltoztatjuk a fiók (6) által tartott minták elosztását, visszamoszatjuk a fiókot (6) a tartószerkezetbe (4), és az olvasó antenna (14) által vett jelek alapján frissítjük a regisztráló eszközben (34, 38) a fiók (6) által tartott mintákra (20) vonatkozó információt.
11. A 9. vagy 10. igénypont szerinti eljárás, amelyben a regisztráló eszköz (34, 38) regisztrálja a fiókban (6) lévő mintákra (20) vonatkozó korábbi információt a fiókban (6) lévő mintákra (20) vonatkozó aktuális információn kívül.
12. A 9., 10. vagy 11. igénypont szerinti eljárás, amelyben a fiók (6) által tartott mintákra (20) vonatkozó tárolt információt a regisztráló eszközzel (34, 38) grafikusán megjelenítjük.
13. A 9–12. igénypontok bármelyike szerinti eljárás, amely magában foglalja, hogy felhasználó azonosító eszközzel (42) azonosítunk egy felhasználót, aki hozzáfér a mintákhoz (20), és ezt az azonosítást annak regisztrálására használjuk, hogy melyik felhasználó fért hozzá a mintákhoz (20), vagy a mintákhoz (20) való hozzáférés ellenőrzésére.