



(51) International Patent Classification:

G02F 1/167 (2006.01) G02F 1/1685 (2019.01)
G02F 1/16766 (2019.01) G09G 3/34 (2006.01)

(21) International Application Number:

PCT/US2022/040697

(22) International Filing Date:

18 August 2022 (18.08.2022)

(25) Filing Language:

English

(26) Publication Language:

English

(30) Priority Data:

63/234,295 18 August 2021 (18.08.2021) US
63/336,331 29 April 2022 (29.04.2022) US

(71) Applicant: **E INK CORPORATION** [US/US]; 1000 Technology Park Drive, Attn: IP Department, Billerica, Massachusetts 01821-4165 (US).

(72) Inventors: **CHEN, Aaron**; c/o E Ink Corporation, 1000 Technology Park Drive, Billerica, Massachusetts 01821-4165 (US). **SIM, Teck Ping**; c/o E Ink Corporation, 1000 Technology Park Drive, Billerica, Massachusetts 01821-4165 (US). **CROUNSE, Kenneth R.**; c/o E Ink Corporation, 1000 Technology Park Drive, Billerica, Massachusetts 01821-4165 (US). **AMUNDSON, Karl**

Raymond; c/o E Ink Corporation, 1000 Technology Park Drive, Billerica, Massachusetts 01821-4165 (US).

(74) Agent: **COLANGELO, Jason P.**; c/o E Ink Corporation, 1000 Technology Park Drive, Attn: IP Department, Billerica, Massachusetts 01821-4165 (US).

(81) Designated States (unless otherwise indicated, for every kind of national protection available): AE, AG, AL, AM, AO, AT, AU, AZ, BA, BB, BG, BH, BN, BR, BW, BY, BZ, CA, CH, CL, CN, CO, CR, CU, CV, CZ, DE, DJ, DK, DM, DO, DZ, EC, EE, EG, ES, FI, GB, GD, GE, GH, GM, GT, HN, HR, HU, ID, IL, IN, IQ, IR, IS, IT, JM, JO, JP, KE, KG, KH, KN, KP, KR, KW, KZ, LA, LC, LK, LR, LS, LU, LY, MA, MD, ME, MG, MK, MN, MW, MX, MY, MZ, NA, NG, NI, NO, NZ, OM, PA, PE, PG, PH, PL, PT, QA, RO, RS, RU, RW, SA, SC, SD, SE, SG, SK, SL, ST, SV, SY, TH, TJ, TM, TN, TR, TT, TZ, UA, UG, US, UZ, VC, VN, WS, ZA, ZM, ZW.

(84) Designated States (unless otherwise indicated, for every kind of regional protection available): ARIPO (BW, GH, GM, KE, LR, LS, MW, MZ, NA, RW, SD, SL, ST, SZ, TZ, UG, ZM, ZW), Eurasian (AM, AZ, BY, KG, KZ, RU, TJ, TM), European (AL, AT, BE, BG, CH, CY, CZ, DE, DK, EE, ES, FI, FR, GB, GR, HR, HU, IE, IS, IT, LT, LU, LV, MC, MK, MT, NL, NO, PL, PT, RO, RS, SE, SI, SK, SM,

(54) Title: METHODS FOR DRIVING ELECTRO-OPTIC DISPLAYS

(57) Abstract: Methods are described for driving an electro-optic display having a plurality of display pixels. Each of the display pixels is associated with a display transistor. The method includes the following steps in order. A first voltage is applied to a first display transistor associated with a first display pixel of the plurality of display pixels. The first voltage is applied during at least one frame of a driving waveform. A second voltage is applied to the first display transistor associated with the first display pixel. The second voltage has a non-zero amplitude less than the first voltage and is applied during the last frame of the driving waveform. The amplitude of the second voltage is based on a voltage offset value and a sum of remnant voltages each frame of the driving waveform contributes to the first display pixel when the first voltage is applied to the first display transistor.

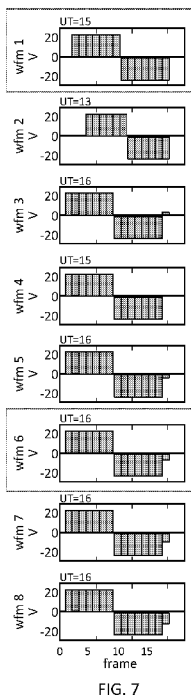

FIG. 7

WO 2023/023213 A1

TR), OAPI (BF, BJ, CF, CG, CI, CM, GA, GN, GQ, GW,
KM, ML, MR, NE, SN, TD, TG).

Declarations under Rule 4.17:

- *as to applicant's entitlement to apply for and be granted a patent (Rule 4.17(ii))*
- *as to the applicant's entitlement to claim the priority of the earlier application (Rule 4.17(iii))*

Published:

- *with international search report (Art. 21(3))*

METHODS FOR DRIVING ELECTRO-OPTIC DISPLAYS

CROSS-REFERENCE TO RELATED APPLICATIONS

[0001] This application claims priority to U.S. Provisional Application No. 63/234,295 filed August 18, 2021, and to U.S. Provisional Application No. 63/336,331 filed April 29, 2022. The entire disclosures of the aforementioned provisional applications are incorporated by reference herein.

FIELD OF THE INVENTION

[0002] The subject matter disclosed herein relates to means and methods to drive electro-optic displays. More particularly, the subject matter is related to driving methods and/or schemes for reducing optical kickback and build-up of remnant voltages caused by residual charges.

BACKGROUND OF THE INVENTION

[0003] Electrophoretic displays or EPDs are commonly driven by so-called DC-balanced waveforms. DC-balanced waveforms have been proven to improve long-term usage of EPDs by reducing severe hardware degradations and eliminating other reliability issues. However, the DC-balance waveform constraint limits the set of possible waveforms that are available to drive the EPD display, making it difficult or sometimes impossible to implement advantageous features via a waveform mode. For example, when implementing a “flash-less” white-on-black display mode, excessive white edge accumulation may become visible when gray-tones that have transitioned to black are next to a non-flashing black background. To clear such edges, a DC-imbalanced drive scheme may have worked well, but such drive scheme requires breaking the DC-balance constraint. Waveforms that are not DC-balanced may result in polarization kickback (e.g., a change in the optical state of an electro-optic medium in a short period after the medium ceases to be driven; for example, a pixel driven to black may revert to a dark gray a short period after the waveform concludes) and cause damage to the electrodes.

[0004] Furthermore, electro-optic displays driven by DC-imbalanced waveforms may produce a remnant voltage, this remnant voltage being ascertainable by measuring the open-circuit electrochemical potential of a display pixel. It has been found that remnant voltage

is a more general phenomenon in electrophoretic and other impulse-driven electro-optic displays, both in cause(s) and effect(s). It has also been found that DC imbalances may cause long-term lifetime degradation of some electrophoretic displays.

SUMMARY OF THE INVENTION

[0005] There exists a need to design driving methods or schemes that address the deficiencies described above. In particular, there exists a need for driving methods or schemes that can eliminate or minimize the hardware degradations caused by optical kickback and remnant voltage.

[0006] In one aspect, the invention includes a method for driving an electro-optic display having a plurality of display pixels where each of the display pixels is associated with a display transistor. The method includes the following steps in order: A first voltage is applied to a first display transistor associated with a first display pixel of the plurality of display pixels. The first voltage is applied during at least one frame of a driving waveform. A second voltage is applied to the first display transistor associated with the first display pixel. The second voltage has a non-zero amplitude less than the first voltage and is applied during the last frame of the driving waveform. The amplitude of the second voltage is based on a voltage offset value and a sum of remnant voltages each frame of the driving waveform contributes to the first display pixel when the first voltage is applied to the first display transistor associated with the first display pixel.

[0007] In some embodiments, the duration of each frame of the driving waveform is substantially the same. In some embodiments, the amplitude of the second voltage is further based on an amount of lightness of the first display pixel resulting from the driving waveform. In some embodiments, the voltage offset value is based on a voltage contributed to the first display pixel due to a change in a gate voltage of the first display transistor and a parasitic capacitance of the first display transistor.

[0008] In some embodiments, the method also includes applying a third voltage to the first display transistor associated with the first display pixel, wherein the third voltage is substantially 0V.

[0009] In some embodiments, an amount of remnant voltage each frame of the driving waveform contributes to the first display pixel when the first voltage is applied to the first display transistor associated with the first display pixel is determined based on the amplitude

of the first voltage and a remnant voltage coefficient corresponding to an amount of remnant voltage a frame of the driving waveform contributes to the display pixel.

[0010] In some embodiments, the method also includes determining the remnant voltage coefficients using an operational transconductance amplifier circuit model.

[0011] In another aspect, the invention includes a method for driving a black-and-white electro-optic display to an optical rail state. The electro-optic display includes an electrophoretic display medium electrically coupled between a plurality of display pixel electrodes and a common electrode. Each of the plurality of display pixel electrodes is associated with a display pixel, and the electrophoretic display medium includes a plurality of electrically charged black pigment particles and electrically charged white pigment particles. The method includes the following steps in order: A first display transistor associated with a first display pixel of the plurality of display pixels is connected to a first voltage driver circuit configured to provide a first voltage sufficient to drive the display pixel to an optical rail state. The first voltage is provided during one or more frames of a driving waveform. The first display transistor associated with the first display pixel of the plurality of display pixels is connected to a second voltage driver circuit configured to provide second voltage having a non-zero amplitude less than the first voltage for reducing an amount of remnant voltage the driving waveform contributes to the first display pixel, wherein the second voltage is provided after the one or more frames of the driving waveform. The first display pixel is placed in a floating state.

[0012] In some embodiments, the optical rail state comprises one of a substantially black state or a substantially white state. In some embodiments, the electrophoretic display medium includes only the plurality of electrically charged black pigment particles and electrically charged white pigment particles.

[0013] In some embodiments, the second voltage is provided for a period of time longer in duration than each frame of the driving waveform. In some embodiments, the second voltage is provided for a period of time shorter in duration than each frame of the driving waveform.

[0014] In some embodiments, connecting the first display transistor associated with the first display pixel of the plurality of display pixels to a first voltage driver circuit includes setting a first switching device in electrical communication with the first voltage driver circuit and a display pixel electrode associated with the first display pixel to a closed state.

[0015] In some embodiments, connecting the first display transistor associated with the first display pixel of the plurality of display pixels to the second voltage driver circuit includes setting the first switching device to an open state, and setting a second switching device in electrical communication with the second voltage driver circuit and a display pixel electrode associated with the first display pixel to a closed state.

[0016] In some embodiments, placing the first display pixel in a floating state comprises setting the second switching device to an open state. In some embodiments, placing the first display pixel in a floating state includes disconnecting an electrical connection between the common electrode and a ground voltage.

[0017] In some embodiments, the first voltage and the second voltage have the same polarity. In some embodiments, the amplitude of the second voltage and a duration of time the second voltage is provided are based on an amount of lightness of the optical rail state resulting from the driving waveform.

BRIEF DESCRIPTION OF DRAWINGS

[0018] FIG. 1 illustrates a circuit diagram representing an exemplary electrophoretic display.

[0019] FIG. 2 shows a circuit model of the electro-optic imaging layer.

[0020] FIG. 3A illustrates a linear ink model of an electrophoretic display.

[0021] FIG. 3B illustrates corresponding voltages for the model illustrated in FIG. 3B.

[0022] FIG. 4 illustrates voltages across an electro-optic medium resulting from shorting and floating after an active drive.

[0023] FIG. 5 illustrates a build-up of residual charges of a DC balanced white-to-white transition.

[0024] FIG. 6 illustrates an exemplary remnant voltage coefficient diagram corresponding to individual frames of a driving waveform.

[0025] FIG. 7 illustrates eight sample driving waveforms.

[0026] FIG. 8 illustrates remnant voltage values corresponding to the waveforms shown in FIG. 7.

[0027] FIG. 9A illustrates an exemplary waveform for driving a display pixel to black.

[0028] FIG. 9B illustrates an exemplary waveform for driving a display pixel to white.

[0029] FIG. 10A illustrates a voltage across an electro-optical medium and the resulting lightness definition.

[0030] FIG. 10B illustrates the end of drive lightness for different combinations of drive voltage and hold time.

[0031] FIG. 11A illustrates another voltages across the electro-optic medium with different wV_L voltages.

[0032] FIG. 11B illustrates the corresponding optical responses to the voltages illustrated in FIG. 11A.

[0033] FIG. 11C illustrates the optical kickbacks as a function of the voltage wV_L .

[0034] FIG. 12 illustrates a build-up of residual charges of a DC balanced white-to-white transition.

[0035] FIG. 13 illustrates one implementation of the driving methods presented herein.

[0036] FIG. 14 illustrates one method to implement the waveforms presented herein.

[0037] FIG. 15A illustrates voltages across an electro-optic medium and optical trace using the waveform presented herein.

[0038] FIG. 15B illustrates voltages across an electro-optic medium and optical trace with floating after an active drive.

[0039] FIG. 15C illustrates voltage across an electro-optic medium and optical trace with shorting after an active drive.

[0040] FIG. 15D illustrates the build-up of residual charges of a DC-balanced white-to-white transition.

DETAILED DESCRIPTION

[0041] The subject matter disclosed herein relates to improving electro-optic display durability. Specifically, it is related to driving methods or schemes designed to minimize remnant voltages or charges, which can cause hardware degradation over time.

[0042] The term “electro-optic”, as applied to a material or a display, is used herein in its conventional meaning in the imaging art to refer to a material having first and second display states differing in at least one optical property, the material being changed from its first to its second display state by application of an electric field to the material. Although the optical property is typically color perceptible to the human eye, it may be another optical property, such as optical transmission, reflectance, luminescence or, in the case of displays

intended for machine reading, pseudo-color in the sense of a change in reflectance of electromagnetic wavelengths outside the visible range.

[0043] The terms “bistable” and “bistability” are used herein in their conventional meaning in the art to refer to displays comprising display elements having first and second display states differing in at least one optical property, and such that after any given element has been driven, by means of an addressing pulse of finite duration, to assume either its first or second display state, after the addressing pulse has terminated, that state will persist for at least several times, for example at least four times, the minimum duration of the addressing pulse required to change the state of the display element. It is shown in U.S. Patent No. 7,170,670 that some particle-based electrophoretic displays capable of gray scale are stable not only in their extreme black and white states but also in their intermediate gray states, and the same is true of some other types of electro-optic displays. This type of display is properly called “multi-stable” rather than bistable, although for convenience the term “bistable” may be used herein to cover both bistable and multi-stable displays.

[0044] The term “gray state” is used herein in its conventional meaning in the imaging art to refer to a state intermediate two extreme optical states of a pixel, and does not necessarily imply a black-white transition between these two extreme states. For example, several of the E Ink patents and published applications referred to below describe electrophoretic displays in which the extreme states are white and deep blue, so that an intermediate “gray state” would actually be pale blue. Indeed, as already mentioned, the change in optical state may not be a color change at all. The terms “black” and “white” may be used hereinafter to refer to the two extreme optical states of a display (also referred to as “optical rail states”), and should be understood as normally including extreme optical states which are not strictly black and white, for example, the aforementioned white and dark blue states. The term “monochrome” may be used hereinafter to denote a display or drive scheme which only drives pixels to their two extreme optical states with no intervening gray states.

[0045] The term “pixel” is used herein in its conventional meaning in the display art to mean the smallest unit of a display capable of generating all the colors which the display itself can show. In a full color display, typically each pixel is composed of a plurality of sub-pixels each of which can display less than all the colors which the display itself can show. For example, in most conventional full color displays, each pixel is composed of a red sub-pixel, a green sub-pixel, a blue sub-pixel, and optionally a white sub-pixel, with

each of the sub-pixels being capable of displaying a range of colors from black to the brightest version of its specified color.

[0046] Several types of electro-optic displays are known. One type of electro-optic display is a rotating bichromal member type as described, for example, in U.S. Patents Nos. 5,808,783; 5,777,782; 5,760,761; 6,054,071 6,055,091; 6,097,531; 6,128,124; 6,137,467; and 6,147,791 (although this type of display is often referred to as a “rotating bichromal ball” display, the term “rotating bichromal member” is preferred as more accurate since in some of the patents mentioned above the rotating members are not spherical). Such a display uses a large number of small bodies (typically spherical or cylindrical) which have two or more sections with differing optical characteristics, and an internal dipole. These bodies are suspended within liquid-filled vacuoles within a matrix, the vacuoles being filled with liquid so that the bodies are free to rotate. The appearance of the display is changed by applying an electric field thereto, thus rotating the bodies to various positions and varying which of the sections of the bodies is seen through a viewing surface. This type of electro-optic medium is typically bistable.

[0047] Another type of electro-optic display uses an electrochromic medium, for example an electrochromic medium in the form of a nanochromic film comprising an electrode formed at least in part from a semi-conducting metal oxide and a plurality of dye molecules capable of reversible color change attached to the electrode; see, for example O'Regan, B., et al., *Nature* 1991, 353, 737; and Wood, D., *Information Display*, 18(3), 24 (March 2002). See also Bach, U., et al., *Adv. Mater.*, 2002, 14(11), 845. Nanochromic films of this type are also described, for example, in U.S. Patents Nos. 6,301,038; 6,870,657; and 6,950,220. This type of medium is also typically bistable.

[0048] Another type of electro-optic display is an electro-wetting display developed by Philips and described in Hayes, R.A., et al., “Video-Speed Electronic Paper Based on Electrowetting”, *Nature*, 425, 383-385 (2003). It is shown in U.S. Patent No. 7,420,549 that such electro-wetting displays can be made bistable.

[0049] One type of electro-optic display, which has been the subject of intense research and development for a number of years, is the particle-based electrophoretic display, in which a plurality of charged particles move through a fluid under the influence of an electric field. Electrophoretic displays can have attributes of good brightness and contrast, wide

viewing angles, state bistability, and low power consumption when compared with liquid crystal displays.

[0050] As noted above, electrophoretic media require the presence of a fluid. In most prior art electrophoretic media, this fluid is a liquid, but electrophoretic media can be produced using gaseous fluids; see, for example, Kitamura, T., et al., “Electrical toner movement for electronic paper-like display”, IDW Japan, 2001, Paper HCS1-1, and Yamaguchi, Y., et al., “Toner display using insulative particles charged triboelectrically”, IDW Japan, 2001, Paper AMD4-4). See also U.S. Patents Nos. 7,321,459 and 7,236,291. Such gas-based electrophoretic media appear to be susceptible to the same types of problems due to particle settling as liquid-based electrophoretic media, when the media are used in an orientation which permits such settling, for example in a sign where the medium is disposed in a vertical plane. Indeed, particle settling appears to be a more serious problem in gas-based electrophoretic media than in liquid-based ones, since the lower viscosity of gaseous suspending fluids as compared with liquid ones allows more rapid settling of the electrophoretic particles.

[0051] Numerous patents and applications assigned to or in the names of the Massachusetts Institute of Technology (MIT) and E Ink Corporation describe various technologies used in encapsulated electrophoretic and other electro-optic media. Such encapsulated media comprise numerous small capsules, each of which itself comprises an internal phase containing electrophoretically-mobile particles in a fluid medium, and a capsule wall surrounding the internal phase. Typically, the capsules are themselves held within a polymeric binder to form a coherent layer positioned between two electrodes. The technologies described in these patents and applications include:

(a) Electrophoretic particles, fluids and fluid additives; see for example U.S. Patents Nos. 7,002,728 and 7,679,814;

(b) Capsules, binders and encapsulation processes; see for example U.S. Patents Nos. 6,922,276 and 7,411,719;

(c) Films and sub-assemblies containing electro-optic materials; see for example U.S. Patents Nos. 6,982,178 and 7,839,564;

(d) Backplanes, adhesive layers and other auxiliary layers and methods used in displays; see for example U.S. Patents Nos. D485,294; 6,124,851; 6,130,773; 6,177,921; 6,232,950; 6,252,564; 6,312,304; 6,312,971; 6,376,828; 6,392,786;

6,413,790; 6,422,687; 6,445,374; 6,480,182; 6,498,114; 6,506,438; 6,518,949; 6,521,489; 6,535,197; 6,545,291; 6,639,578; 6,657,772; 6,664,944; 6,680,725; 6,683,333; 6,724,519; 6,750,473; 6,816,147; 6,819,471; 6,825,068; 6,831,769; 6,842,167; 6,842,279; 6,842,657; 6,865,010; 6,873,452; 6,909,532; 6,967,640; 6,980,196; 7,012,735; 7,030,412; 7,075,703; 7,106,296; 7,110,163; 7,116,318***; 7,148,128; 7,167,155; 7,173,752; 7,176,880; 7,190,008; 7,206,119; 7,223,672; 7,230,751; 7,256,766; 7,259,744; 7,280,094; 7,301,693; 7,304,780; 7,327,511; 7,347,957; 7,349,148; 7,352,353; 7,365,394; 7,365,733; 7,382,363; 7,388,572; 7,401,758; 7,442,587; 7,492,497; 7,535,624;*** 7,551,346; 7,554,712; 7,583,427; 7,598,173; 7,605,799; 7,636,191; 7,649,674; 7,667,886; 7,672,040; 7,688,497; 7,733,335; 7,785,988; 7,830,592; 7,843,626; 7,859,637; 7,880,958; 7,893,435; 7,898,717; 7,905,977; 7,957,053; 7,986,450; 8,009,344; 8,027,081; 8,049,947; 8,072,675; 8,077,141; 8,089,453; 8,120,836; 8,159,636; 8,208,193; 8,237,892; 8,238,021; 8,362,488; 8,373,211; 8,389,381; 8,395,836; 8,437,069; 8,441,414; 8,456,589; 8,498,042; 8,514,168; 8,547,628; 8,576,162; 8,610,988; 8,714,780; 8,728,266; 8,743,077; 8,754,859; 8,797,258; 8,797,633; 8,797,636; 8,830,560; 8,891,155; 8,969,886; 9,147,364; 9,025,234; 9,025,238; 9,030,374; 9,140,952; 9,152,003; 9,152,004; 9,201,279; 9,223,164; 9,285,648; and 9,310,661; and U.S. Patent Applications Publication Nos. 2002/0060321; 2004/0008179; 2004/0085619; 2004/0105036; 2004/0112525; 2005/0122306; 2005/0122563; 2006/0215106; 2006/0255322; 2007/0052757; 2007/0097489; 2007/0109219; 2008/0061300; 2008/0149271; 2009/0122389; 2009/0315044; 2010/0177396; 2011/0140744; 2011/0187683; 2011/0187689; 2011/0292319; 2013/0250397; 2013/0278900; 2014/0078024; 2014/0139501; 2014/0192000; 2014/0210701; 2014/0300837; 2014/0368753; 2014/0376164; 2015/0171112; 2015/0205178; 2015/0226986; 2015/0227018; 2015/0228666; 2015/0261057; 2015/0356927; 2015/0378235; 2016/077375; 2016/0103380; and 2016/0187759; and International Application Publication No. WO 00/38000; European Patents Nos. 1,099,207 B1 and 1,145,072 B1;

(e) Color formation and color adjustment; see for example U.S. Patents Nos. 6,017,584; 6,664,944; 6,864,875; 7,075,502; 7,167,155; 7,667,684; 7,791,789; 7,956,841; 8,040,594; 8,054,526; 8,098,418; 8,213,076; and 8,363,299; and U.S.

Patent Applications Publication Nos. 2004/0263947; 2007/0109219; 2007/0223079; 2008/0023332; 2008/0043318; 2008/0048970; 2009/0004442; 2009/0225398; 2010/0103502; 2010/0156780; 2011/0164307; 2011/0195629; 2011/0310461; 2012/0008188; 2012/0019898; 2012/0075687; 2012/0081779; 2012/0134009; 2012/0182597; 2012/0212462; 2012/0157269; and 2012/0326957; (f)

Methods for driving displays; see for example U.S. Patents Nos. 7,012,600 and 7,453,445;

(g) Applications of displays; see for example U.S. Patents Nos. 7,312,784 and 8,009,348;

(h) Non-electrophoretic displays, as described in U.S. Patents Nos. 6,241,921; 6,950,220; 7,420,549 and 8,319,759; and U.S. Patent Application Publication No. 2012/0293858;

(i) Microcell structures, wall materials, and methods of forming microcells; see for example United States Patents Nos. 7,072,095 and 9,279,906; and

(j) Methods for filling and sealing microcells; see for example United States Patents Nos. 7,144,942 and 7,715,088.

[0052] This application is further related to U.S. Patents Nos. D485,294; 6,124,851; 6,130,773; 6,177,921; 6,232,950; 6,252,564; 6,312,304; 6,312,971; 6,376,828; 6,392,786; 6,413,790; 6,422,687; 6,445,374; 6,480,182; 6,498,114; 6,506,438; 6,518,949; 6,521,489; 6,535,197; 6,545,291; 6,639,578; 6,657,772; 6,664,944; 6,680,725; 6,683,333; 6,724,519; 6,750,473; 6,816,147; 6,819,471; 6,825,068; 6,831,769; 6,842,167; 6,842,279; 6,842,657; 6,865,010; 6,873,452; 6,909,532; 6,967,640; 6,980,196; 7,012,735; 7,030,412; 7,075,703; 7,106,296; 7,110,163; 7,116,318; 7,148,128; 7,167,155; 7,173,752; 7,176,880; 7,190,008; 7,206,119; 7,223,672; 7,230,751; 7,256,766; 7,259,744; 7,280,094; 7,301,693; 7,304,780; 7,327,511; 7,347,957; 7,349,148; 7,352,353; 7,365,394; 7,365,733; 7,382,363; 7,388,572; 7,401,758; 7,442,587; 7,492,497; 7,535,624; 7,551,346; 7,554,712; 7,583,427; 7,598,173; 7,605,799; 7,636,191; 7,649,674; 7,667,886; 7,672,040; 7,688,497; 7,733,335; 7,785,988; 7,830,592; 7,843,626; 7,859,637; 7,880,958; 7,893,435; 7,898,717; 7,905,977; 7,957,053; 7,986,450; 8,009,344; 8,027,081; 8,049,947; 8,072,675; 8,077,141; 8,089,453; 8,120,836; 8,159,636; 8,208,193; 8,237,892; 8,238,021; 8,362,488; 8,373,211; 8,389,381; 8,395,836; 8,437,069; 8,441,414; 8,456,589; 8,498,042; 8,514,168; 8,547,628; 8,576,162; 8,610,988;

8,714,780; 8,728,266; 8,743,077; 8,754,859; 8,797,258; 8,797,633; 8,797,636; 8,830,560; 8,891,155; 8,969,886; 9,147,364; 9,025,234; 9,025,238; 9,030,374; 9,140,952; 9,152,003; 9,152,004; 9,201,279; 9,223,164; 9,285,648; and 9,310,661; and U.S. Patent Applications Publication Nos. 2002/0060321; 2004/0008179; 2004/0085619; 2004/0105036; 2004/0112525; 2005/0122306; 2005/0122563; 2006/0215106; 2006/0255322; 2007/0052757; 2007/0097489; 2007/0109219; 2008/0061300; 2008/0149271; 2009/0122389; 2009/0315044; 2010/0177396; 2011/0140744; 2011/0187683; 2011/0187689; 2011/0292319; 2013/0250397; 2013/0278900; 2014/0078024; 2014/0139501; 2014/0192000; 2014/0210701; 2014/0300837; 2014/0368753; 2014/0376164; 2015/0171112; 2015/0205178; 2015/0226986; 2015/0227018; 2015/0228666; 2015/0261057; 2015/0356927; 2015/0378235; 2016/077375; 2016/0103380; and 2016/0187759; and International Application Publication No. WO 00/38000; European Patents Nos. 1,099,207 B1 and 1,145,072 B1; all of the above-listed applications are incorporated by reference in their entireties.

[0053] This application is also related to U.S. Patents Nos. 5,930,026; 6,445,489; 6,504,524; 6,512,354; 6,531,997; 6,753,999; 6,825,970; 6,900,851; 6,995,550; 7,012,600; 7,023,420; 7,034,783; 7,061,166; 7,061,662; 7,116,466; 7,119,772; 7,177,066; 7,193,625; 7,202,847; 7,242,514; 7,259,744; 7,304,787; 7,312,794; 7,327,511; 7,408,699; 7,453,445; 7,492,339; 7,528,822; 7,545,358; 7,583,251; 7,602,374; 7,612,760; 7,679,599; 7,679,813; 7,683,606; 7,688,297; 7,729,039; 7,733,311; 7,733,335; 7,787,169; 7,859,742; 7,952,557; 7,956,841; 7,982,479; 7,999,787; 8,077,141; 8,125,501; 8,139,050; 8,174,490; 8,243,013; 8,274,472; 8,289,250; 8,300,006; 8,305,341; 8,314,784; 8,373,649; 8,384,658; 8,456,414; 8,462,102; 8,537,105; 8,558,783; 8,558,785; 8,558,786; 8,558,855; 8,576,164; 8,576,259; 8,593,396; 8,605,032; 8,643,595; 8,665,206; 8,681,191; 8,730,153; 8,810,525; 8,928,562; 8,928,641; 8,976,444; 9,013,394; 9,019,197; 9,019,198; 9,019,318; 9,082,352; 9,171,508; 9,218,773; 9,224,338; 9,224,342; 9,224,344; 9,230,492; 9,251,736; 9,262,973; 9,269,311; 9,299,294; 9,373,289; 9,390,066; 9,390,661; and 9,412,314; and U.S. Patent Applications Publication Nos. 2003/0102858; 2004/0246562; 2005/0253777; 2007/0070032; 2007/0076289; 2007/0091418; 2007/0103427; 2007/0176912; 2007/0296452; 2008/0024429; 2008/0024482; 2008/0136774; 2008/0169821; 2008/0218471; 2008/0291129; 2008/0303780; 2009/0174651; 2009/0195568; 2009/0322721; 2010/0194733; 2010/0194789; 2010/0220121; 2010/0265561; 2010/0283804;

2011/0063314; 2011/0175875; 2011/0193840; 2011/0193841; 2011/0199671;
2011/0221740; 2012/0001957; 2012/0098740; 2013/0063333; 2013/0194250;
2013/0249782; 2013/0321278; 2014/0009817; 2014/0085355; 2014/0204012;
2014/0218277; 2014/0240210; 2014/0240373; 2014/0253425; 2014/0292830;
2014/0293398; 2014/0333685; 2014/0340734; 2015/0070744; 2015/0097877;
2015/0109283; 2015/0213749; 2015/0213765; 2015/0221257; 2015/0262255;
2016/0071465; 2016/0078820; 2016/0093253; 2016/0140910; and 2016/0180777; all of the
above-listed applications are incorporated by reference in their entireties.

[0054] Many of the aforementioned patents and applications recognize that the walls surrounding the discrete microcapsules in an encapsulated electrophoretic medium could be replaced by a continuous phase, thus producing a so-called polymer-dispersed electrophoretic display, in which the electrophoretic medium comprises a plurality of discrete droplets of an electrophoretic fluid and a continuous phase of a polymeric material, and that the discrete droplets of electrophoretic fluid within such a polymer-dispersed electrophoretic display may be regarded as capsules or microcapsules even though no discrete capsule membrane is associated with each individual droplet; see for example, the aforementioned U.S. Patent No. 6,866,760. Accordingly, for purposes of the present application, such polymer-dispersed electrophoretic media are regarded as sub-species of encapsulated electrophoretic media.

[0055] A related type of electrophoretic display is a so-called “microcell electrophoretic display”. In a microcell electrophoretic display, the charged particles and the fluid are not encapsulated within microcapsules but instead are retained within a plurality of cavities formed within a carrier medium, typically a polymeric film. See, for example, U.S. Patents Nos. 6,672,921 and 6,788,449, both assigned to Sipix Imaging, Inc.

[0056] Although electrophoretic media are often opaque (since, for example, in many electrophoretic media, the particles substantially block transmission of visible light through the display) and operate in a reflective mode, many electrophoretic displays can be made to operate in a so-called “shutter mode” in which one display state is substantially opaque and one is light-transmissive. See, for example, U.S. Patents Nos. 5,872,552; 6,130,774; 6,144,361; 6,172,798; 6,271,823; 6,225,971; and 6,184,856. Dielectrophoretic displays, which are similar to electrophoretic displays but rely upon variations in electric field strength, can operate in a similar mode; see U.S. Patent No. 4,418,346. Other types of

electro-optic displays may also be capable of operating in shutter mode. Electro-optic media operating in shutter mode may be useful in multi-layer structures for full color displays; in such structures, at least one layer adjacent the viewing surface of the display operates in shutter mode to expose or conceal a second layer more distant from the viewing surface.

[0057] An encapsulated electrophoretic display typically does not suffer from the clustering and settling failure mode of traditional electrophoretic devices and provides further advantages, such as the ability to print or coat the display on a wide variety of flexible and rigid substrates. (Use of the word “printing” is intended to include all forms of printing and coating, including, but without limitation: pre-metered coatings such as patch die coating, slot or extrusion coating, slide or cascade coating, curtain coating; roll coating such as knife over roll coating, forward and reverse roll coating; gravure coating; dip coating; spray coating; meniscus coating; spin coating; brush coating; air knife coating; silk screen printing processes; electrostatic printing processes; thermal printing processes; ink jet printing processes; electrophoretic deposition (See U.S. Patent No. 7,339,715); and other similar techniques.) Thus, the resulting display can be flexible. Further, because the display medium can be printed, using a variety of methods, the display itself can be made inexpensively.

[0058] Other types of electro-optic materials may also be used in the present invention.

[0059] An electrophoretic display normally comprises a layer of electrophoretic material and at least two other layers disposed on opposed sides of the electrophoretic material, one of these two layers being an electrode layer. In most such displays both the layers are electrode layers, and one or both of the electrode layers are patterned to define the pixels of the display. For example, one electrode layer may be patterned into elongate row electrodes and the other into elongate column electrodes running at right angles to the row electrodes, the pixels being defined by the intersections of the row and column electrodes. Alternatively, and more commonly, one electrode layer has the form of a single continuous electrode and the other electrode layer is patterned into a matrix of pixel electrodes, each of which defines one pixel of the display. In another type of electrophoretic display, which is intended for use with a stylus, print head or similar movable electrode separate from the display, only one of the layers adjacent the electrophoretic layer comprises an electrode, the layer on the opposed side of the electrophoretic layer typically being a

protective layer intended to prevent the movable electrode damaging the electrophoretic layer.

[0060] In yet another embodiment, such as described in U.S. Pat. No. 6,704,133, electrophoretic displays may be constructed with two continuous electrodes and an electrophoretic layer and a photoelectrophoretic layer between the electrodes. Because the photoelectrophoretic material changes resistivity with the absorption of photons, incident light can be used to alter the state of the electrophoretic medium. Such a device is illustrated in FIG. 1. As described in U.S. Pat. No. 6,704,133, the device of FIG. 1 works best when driven by an emissive source, such as an LCD display, located on the opposed side of the display from the viewing surface. In some embodiments, the devices of U.S. Pat. No. 6,704,133 incorporated special barrier layers between the front electrode and the photoelectrophoretic material to reduce “dark currents” caused by incident light from the front of the display that leaks past the reflective electro-optic media.

[0061] The aforementioned U.S. Patent No. 6,982,178 describes a method of assembling a solid electro-optic display (including an encapsulated electrophoretic display) which is well adapted for mass production. Essentially, this patent describes a so-called “front plane laminate” (“FPL”) which comprises, in order, a light-transmissive electrically-conductive layer; a layer of a solid electro-optic medium in electrical contact with the electrically-conductive layer; an adhesive layer; and a release sheet. Typically, the light-transmissive electrically-conductive layer will be carried on a light-transmissive substrate, which is preferably flexible, in the sense that the substrate can be manually wrapped around a drum (say) 10 inches (254 mm) in diameter without permanent deformation. The term “light-transmissive” is used in this patent and herein to mean that the layer thus designated transmits sufficient light to enable an observer, looking through that layer, to observe the change in display states of the electro-optic medium, which will normally be viewed through the electrically-conductive layer and adjacent substrate (if present); in cases where the electro-optic medium displays a change in reflectivity at non-visible wavelengths, the term “light-transmissive” should of course be interpreted to refer to transmission of the relevant non-visible wavelengths. The substrate will typically be a polymeric film, and will normally have a thickness in the range of about 1 to about 25 mil (25 to 634 μm), preferably about 2 to about 10 mil (51 to 254 μm). The electrically-conductive layer is conveniently a thin metal or metal oxide layer of, for example, aluminum or ITO, or may be a conductive

polymer. Poly (ethylene terephthalate) (PET) films coated with aluminum or ITO are available commercially, for example as “aluminized Mylar” (“Mylar” is a Registered Trade Mark) from E.I. du Pont de Nemours & Company, Wilmington DE, and such commercial materials may be used with good results in the front plane laminate.

[0062] It has now been found that remnant voltage is a more general phenomenon in electrophoretic and other impulse-driven electro-optic displays, both in cause(s) and effect(s). It has also been found that DC imbalances may cause long-term lifetime degradation of some electrophoretic displays.

[0063] There are multiple potential sources of remnant voltage. It is believed (although some embodiments are in no way limited by this belief), that a primary cause of remnant voltage is ionic polarization within the materials of the various layers forming the display.

[0064] Such polarization occurs in various ways. In a first (for convenience, denoted “Type I”) polarization, an ionic double layer is created across or adjacent a material interface. For example, a positive potential at an indium-tin-oxide (“ITO”) electrode may produce a corresponding polarized layer of negative ions in an adjacent laminating adhesive. The decay rate of such a polarization layer is associated with the recombination of separated ions in the lamination adhesive layer. The geometry of such a polarization layer is determined by the shape of the interface, but may be planar in nature.

[0065] In a second (“Type II”) type of polarization, nodules, crystals or other kinds of material heterogeneity within a single material can result in regions in which ions can move or less quickly than the surrounding material. The differing rate of ionic migration can result in differing degrees of charge polarization within the bulk of the medium, and polarization may thus occur within a single display component. Such a polarization may be substantially localized in nature or dispersed throughout the layer.

[0066] In a third (“Type III”) type of polarization, polarization may occur at any interface that represents a barrier to charge transport of any particular type of ion. One example of such an interface in a microcavity electrophoretic display is the boundary between the electrophoretic suspension including the suspending medium and particles (the “internal phase”) and the surrounding medium including walls, adhesives and binders (the “external phase”). In many electrophoretic displays, the internal phase is a hydrophobic liquid whereas the external phase is a polymer, such as gelatin. Ions that are

present in the internal phase may be insoluble and non-diffusible in the external phase and vice versa. On the application of an electric field perpendicular to such an interface, polarization layers of opposite sign will accumulate on either side of the interface. When the applied electric field is removed, the resulting non-equilibrium charge distribution will result in a measurable remnant voltage potential that decays with a relaxation time determined by the mobility of the ions in the two phases on either side of the interface.

[0067] Polarization may occur during a drive pulse. Each image update is an event that may affect remnant voltage. A positive waveform voltage can create a remnant voltage across an electro-optic medium that is of the same or opposite polarity (or nearly zero) depending on the specific electro-optic display.

[0068] In some instances, the last frame of a driving sequence may contribute the highest level to the polarization of the ink stack. For example, sometimes a last frame can contribute multiple times (e.g., 10x) more remnant charges to the ink stack than a previous frame.

[0069] It will be evident from the foregoing discussion that polarization may occur at multiple locations within the electrophoretic or other electro-optic display, each location having its own characteristic spectrum of decay times, principally at interfaces and at material heterogeneities. Depending on the placement of the sources of these voltages (in other words, the polarized charge distribution) relative to the electro-active parts (for example, the electrophoretic suspension), and the degree of electrical coupling between each kind of charge distribution and the motion of the particles through the suspension, or other electro-optic activity, various kinds of polarization will produce more or less deleterious effects. Since an electrophoretic display operates by motion of charged particles, which inherently causes a polarization of the electro-optic layer, in a sense a preferred electrophoretic display is not one in which no remnant voltages are always present in the display, but rather one in which the remnant voltages do not cause objectionable electro-optic behavior. Ideally, the remnant impulse will be minimized and the remnant voltage will decrease below 1 V, and preferably below 0.2 V, within 1 second, and preferably within 50 ms, so that that by introducing a minimal pause between image updates, the electrophoretic display may affect all transitions between optical states without concern for remnant voltage effects. For electrophoretic displays operating at

video rates or at voltages below +/-15 V these ideal values should be correspondingly reduced. Similar considerations apply to other types of electro-optic display.

[0070] To summarize, remnant voltage as a phenomenon is at least substantially a result of ionic polarization occurring within the display material components, either at interfaces or within the materials themselves. Such polarizations are especially problematic when they persist on a time scale of roughly 50 ms to about an hour or longer. Remnant voltage can present itself as image ghosting or visual artifacts in a variety of ways, with a degree of severity that can vary with the elapsed times between image updates. Remnant voltage can also create a DC imbalance and reduce ultimate display lifetime. The effects of remnant voltage therefore may be deleterious to the quality of the electrophoretic or other electro-optic device and it is desirable to minimize both the remnant voltage itself, and the sensitivity of the optical states of the device to the influence of the remnant voltage.

[0071] FIG. 1 shows a schematic of a pixel 100 of an electro-optic display in accordance with the subject matter submitted herein. Pixel 100 may include an imaging film 110. In some embodiments, imaging film 110 may be bistable. In some embodiments, imaging film 110 may include, without limitation, an encapsulated electrophoretic imaging film, which may include, for example, charged pigment particles.

[0072] Imaging film 110 may be disposed between a front electrode 102 and a rear electrode 104. Front electrode 102 may be formed between the imaging film and the front of the display. In some embodiments, front electrode 102 may be transparent. In some embodiments, front electrode 102 may be formed of any suitable transparent material, including, without limitation, indium tin oxide (ITO). Rear electrode 104 may be formed opposite a front electrode 102. In some embodiments, a parasitic capacitance (not shown) may be formed between front electrode 102 and rear electrode 104.

[0073] Pixel 100 may be one of a plurality of pixels. The plurality of pixels may be arranged in a two-dimensional array of rows and columns to form a matrix, such that any specific pixel is uniquely defined by the intersection of one specified row and one specified column. In some embodiments, the matrix of pixels may be an “active matrix,” in which each pixel is associated with at least one non-linear circuit element 120. The non-linear circuit element 120 may be coupled between back-plate electrode 104 and an addressing electrode 108. In some embodiments, non-linear element 120 may include a diode and/or a

transistor, including, without limitation, a MOSFET. The drain (or source) of the MOSFET may be coupled to back-plate electrode 104, the source (or drain) of the MOSFET may be coupled to addressing electrode 108, and the gate of the MOSFET may be coupled to a driver electrode 106 configured to control the activation and deactivation of the MOSFET. (For simplicity, the terminal of the MOSFET coupled to back-plate electrode 104 will be referred to as the MOSFET's drain, and the terminal of the MOSFET coupled to addressing electrode 108 will be referred to as the MOSFET's source. However, one of ordinary skill in the art will recognize that, in some embodiments, the source and drain of the MOSFET may be interchanged.)

[0074] In some embodiments of the active matrix, the addressing electrodes 108 of all the pixels in each column may be connected to a same column electrode, and the driver electrodes 106 of all the pixels in each row may be connected to a same row electrode. The row electrodes may be connected to a row driver, which may select one or more rows of pixels by applying to the selected row electrodes a voltage sufficient to activate the non-linear elements 120 of all the pixels 100 in the selected row(s). The column electrodes may be connected to column drivers, which may place upon the addressing electrode 106 of a selected (activated) pixel a voltage suitable for driving the pixel into a desired optical state. The voltage applied to an addressing electrode 108 may be relative to the voltage applied to the pixel's front-plate electrode 102 (e.g., a voltage of approximately zero volts). In some embodiments, the front-plate electrodes 102 of all the pixels in the active matrix may be coupled to a common electrode.

[0075] In some embodiments, the pixels 100 of the active matrix may be written in a row-by-row manner. For example, a row of pixels may be selected by the row driver, and the voltages corresponding to the desired optical states for the row of pixels may be applied to the pixels by the column drivers. After a pre-selected interval known as the "line address time," the selected row may be deselected, another row may be selected, and the voltages on the column drivers may be changed so that another line of the display is written.

[0076] FIG. 2 shows a circuit model of the electro-optic imaging layer 110 disposed between the front electrode 102 and the rear electrode 104 in accordance with the subject matter presented herein. Resistor 202 and capacitor 204 may represent the resistance and capacitance of the electro-optic imaging layer 110, the front electrode 102 and the rear electrode 104, including any adhesive layers. Resistor 212 and capacitor 214 may represent

the resistance and capacitance of a lamination adhesive layer. Capacitor 216 may represent a capacitance that may form between the front electrode 102 and the back electrode 104, for example, interfacial contact areas between layers, such as the interface between the imaging layer and the lamination adhesive layer and/or between the lamination adhesive layer and the backplane electrode. A voltage V_i across a pixel's imaging film 110 may include the pixel's remnant voltage.

[0077] In another view representing the electro-optic medium, referring now to FIG. 3A and FIG. 3B, V_1 represent the voltage across the internal phase of the ink; V_2 represents the voltage across the external phase and V_3 represents the voltage across the interfacial layer of the adhesive and electrode. The capacitance and resistance values may be determined by fitting the model to actual experimental data. Based on these capacitance and resistance values, FIG. 3B shows the voltage across the internal, external and interfacial layers. As shown, the internal phase of the ink exhibits a reversal of drive voltage during shorting that results in optical kickback.

[0078] One way to avoid this optical kickback is to float the pixel at the end of the active drive (i.e., power off the gate, and in some instances the source, of the TFT corresponding to the pixel, thereby isolating the pixel from any conductive path). Avoiding optical kickback may be beneficial for the extreme dark/black and white state as these optical rails (e.g., the two extreme optical states of the electro-optic medium; typically black and white) influence the achievable dynamic range of the display and hence, the fundamental optical quality of the display. FIG. 4 illustrates the optical effects and remnant voltage decay with shorting (a) and floating (b) after an active drive with a test glass. Referring now to FIG. 5, while floating after an active drive addresses the optical kickback issue, the build-up of residual charge (as measured by the steady state remnant voltage in FIG. 5) in the electro-optic medium is higher and can be potentially damaging to the display. This is the reason why in typical drive in both the segmented and active matrix display, shorting may be used after an active drive to reduce the build-up of residual charge.

[0079] In practice, charges built up within an electrophoretic material due to polarization effect described above may be mitigated to reduce the remnant voltage effect. For example, by reduce the voltage level of the last frame of a driving sequence.

[0080] In some embodiments, the change in remnant voltage by an applied driving waveform $V(k)$ with N frames may be predicted as

$$\Delta V_{\text{rem}} = V_{\text{offset}} + \sum_{k=1 \sim N} V(k) * b(N-k+1) \quad (1)$$

Where the change in remnant voltage ΔV_{rem} is the sum of an offset voltage V_{offset} and a summation of the remnant voltages contributed by each frame of the driving waveform, the offset V_{offset} being the voltage added due to the gate voltage change and the TFT parasitic capacitances. In practice, each frame of the driving waveform contributes a certain amount of remnant voltage as dictated by the remnant voltage coefficient b , where in some instances, the remnant voltage coefficient b is the highest for the last frame of the drive. The remnant voltage coefficient b may be determined experimentally or calculated mathematically using models such as an Ota circuit model.

[0081] Referring now to FIG. 6, illustrated herein is an exemplary remnant voltage coefficient curve determined by fitting a linear remnant voltage model of equation (1) to measured remnant voltage change on an active matrix display (e.g., an electrophoretic display) using a plurality of random waveforms. As FIG. 6 shows, the last frame contributes to the highest level to the polarization of the ink stack, resulting in a 10x higher remnant voltage coefficient ($b(1)$) than the earlier frames ($b(k>1)$).

[0082] In practice, adjusting the voltage amplitude of the last frame of a drive sequence or driving scheme or driving waveform to a right level can result in a reduced remnant charges or voltages generated. Referring now to FIG. 7, where eight waveforms with different last frame voltage amplitudes are applied to a display. Specifically, waveform 1 shows a last frame having a same voltage as the previous frames, and in contrast, waveform 6 shows a last frame having a lower voltage compared to previous frames. The resulting remnant voltage values are presented in FIG. 8 where waveform 6 (i.e., approximately 4.2 volts in absolute value) resulted in a reduced remnant voltage generated compared to that of waveform 1 (i.e., approximately 5.2 volts in absolute value). In general, to achieve a better optical state and also reduce remnant voltage built-up, and for the purpose of illustrate the working principle presented herein, a white-to-white transition is used here as an example where a negative voltage drives a display pixel to white, the

$$\Delta V_{\text{rem, new}} \geq \Delta V_{\text{rem, old}} \quad (2)$$

$$L_{\text{new}} \geq L_{\text{old}} \quad (3)$$

Where the change in remnant voltage due to applying the new waveform $\Delta V_{\text{rem, new}}$ is larger than or equal to the change in remnant voltage due to applying the old waveform $\Delta V_{\text{rem, old}}$, but it should be noted that since discussed here is a white-to-white transition where negative voltages are used to drive the display pixels and the resulting remnant voltages are negative in value as well, as such, $\Delta V_{\text{rem, new}} \geq \Delta V_{\text{rem, old}}$ means the change in remnant voltage due to the new waveform is less negative than if the old waveform is applied, because less remnant voltage is generated by the new waveform.

[0083] Furthermore, if equation (2) is expressed in terms of equation (1), then

$$\begin{aligned} & \sum_{k=1 \sim N} V(k) * b(N-k+1+\Delta k) + V_{\text{low}} * b(1+\Delta k) \geq \sum_{k=1 \sim N} V(k) * b(N-k+1) \\ \rightarrow & V_{\text{low}} \geq V_{\text{low}}^* = [1 / b(1+\Delta k)] * \sum_{k=1 \sim N} V(k) * [b(N-k+1) - b(N-k+1+\Delta k)] \quad (4) \end{aligned}$$

which means that the low voltage V_{low} at the end of a waveform shifted by Δk frames needs to be smaller in magnitude than or equal to V_{low}^* as defined in Equation (4), while the lightness of the display pixel resulting from the new waveform (L_{new}) needs to be whiter than or equal to that of the old waveform (L_{old}), in order to achieve enhanced lightness at a smaller remnant voltage cost.

[0084] In some embodiments, optical kickback can be avoided by not shorting at the end of an active drive, but instead, pulling the voltage applied to the display pixel to a lower voltage of the same polarity as the drive pulse that does not results in optical kickback, and is small enough to avoid excessive build-up of residual charges. The techniques described herein can be particularly effective for electro-optic displays having an electrophoretic medium incorporating only types of colored pigment particles. In some embodiments, the methods described herein are carried out on black-and-white electro-optic displays having an electrophoretic medium incorporating only charged black pigment particles and charged white pigment particles.

[0085] FIG. 9A and FIG. 9B illustrate driving waveforms for driving a display pixel to a black state and a white state, respectively. The illustrated shaped waveform pulses are presented herein for illustration purposes only. One of ordinary skill in the art will appreciate that the working principals herein can be applied to waveforms of other shapes and for other optical transitions.

[0086] In some embodiments, in constructing a waveform to minimize the optical kickback and the residual charges, one may select a ${}^wV_H \leq -10V$, ${}^wt_H > 20ms$ (wV_H , wt_H) pair such that the white optical rail is reached. FIG. 10A illustrates a voltage across an electro-optical medium and the resulting lightness definition, and FIG. 10B illustrates the end of drive lightness L^* for different combinations of voltage, wV_H and time, wt_H . A combination of wV_H and wt_H can be selected to achieve the necessary lightness of the optical white rail. The same methodology using ${}^bV_H \geq 10V$ and ${}^bt_H > 20ms$ can be applied for driving a display pixel to the black optical rail. Secondly, values in the range of $0 > {}^wV_L \geq -10V$ for ${}^wt_L > 20ms$ can be selected such that optical kickback is negligible or to an acceptable level. The minimum wV_L may be selected to lower the impact of remnant voltage on the display module. Furthermore, the update time can be further reduced by increasing wV_H and reducing wt_H as suggested by FIG. 10B to compensate for the extra time needed for wt_L . . One of ordinary skill in the art will appreciate that this method can be adopted for driving display pixels to a black optical state.

[0087] In some embodiments, values for wV_H and wt_H can be selected based on the plots shown in FIG. 11A, FIG. 11B, and FIG. 11C, which help illustrate tradeoffs between the values of wV_H and wt_H to achieve the desired optical rail. In some embodiments, a higher wV_H can increase ink speed and reduce the time wt_H to achieve the desired optical rail and vice versa. Selecting wV_H and wt_H may be determined based on desired maximum update time and desired white state rail requirements. Referring now to FIG. 11C, as an example, for a white to white drive with ${}^wV_H = 15V$ and ${}^wt_H = 247.1ms$, selecting a ${}^wV_L = 5V$ can reduce optical kickback by more than $0.6 L^*$ over a driving scheme in which the display pixel is shorted to $0V$ at the end of the driving waveform without reducing the drive voltage.

[0088] The same methodology with bV_L in the range of $0 < {}^bV_L \leq 10V$ and ${}^bt_L > 20ms$ can be employed for the black rail. Furthermore, a minimized ${}^wt_L > 20ms$ and ${}^bt_L > 20ms$ may be selected such that the residual charge build-up on the module is minimized. A minimum wt_L and bt_L are desired here for this special waveform update to reduce impact on the total waveform update time. In some embodiments, a value for wt_L can be selected based on the plots shown in FIG. 12. FIG. 12 illustrates the residual charge build-up in the electro-optic medium (as measured by the steady state remnant voltage) for different wt_L times. In one embodiment, selecting a ${}^wt_L = 141.2ms$ allows one to achieve a good tradeoff between minimizing the residual charge build-up and overall update time of the waveform.

[0089] In some embodiments, the selected (wV_L , wt_L) pair may be fixed for a given ink platform at the end of a normal pulse drive dictated by the (wV_H , wt_H) pair. Similarly the selected (bV_L , bt_L) pair may be fixed for a given ink platform at the end of a normal pulse drive dictated by the (bV_H , bt_H) pair. This configuration provides the flexibility to use rail voltage modulation (as given in the preceding implementation section) to achieve the desired low voltage setting with an active matrix display. In addition, an impulse potential in V.ms can be used as a measure to maintain DC balancing of the driving waveform, where this impulse potential may be defined as:

$$\begin{aligned} \text{impulse potential V.ms (drive pulse to white)} &= {}^wV_H * {}^wt_H + {}^wV_L * {}^wt_L \\ \text{impulse potential V.ms (drive pulse to black)} &= {}^bV_H * {}^bt_H + {}^bV_L * {}^bt_L \end{aligned}$$

[0090] Finally, one may choose to keep the display pixels in an electrically floating state after the completion of a drive waveform.

[0091] In practice, the subject matter disclosed herein may be implemented as illustrated in FIG. 13. In some embodiments, the selection of wV_H , wV_L , bV_H and bV_L for wt_H , wt_L , bt_H and bt_L duration respectively may be controlled by switches SW1, SW2, SW3 and SW4 respectively. And floating may be achieved at the end of the drive by setting all the switches (SW1 to SW4) to an open state. For example, for an active matrix display, an exemplary waveform may be implemented by setting the wV_H , wV_L , bV_H and bV_L values for the wt_H , wt_L , bt_H and bt_L durations with wt_H , wt_L , bt_H and bt_L being multiples of the frame time, as described in U.S. Patent 8,125,501, which is incorporated herein in its entirety, using voltage modulated driving systems. And then floating at the end of the low voltage drive can be achieved by using a high impedance switch on the VCOM_PANEL line to float the common electrode.

[0092] In another embodiment, for an active matrix display, a waveform may be implemented by selecting wV_H , wV_L , bV_H and bV_L values for wt_H , wt_L , bt_H and bt_L durations with wt_H , wt_L , bt_H and bt_L being multiples of the frame time by modulating the supply rail voltages (i.e. VPOS and VNEG) as shown in FIG. 14. In this configuration, transition to intermediate graytones (other than to black and to white) would be forced to i) select zero drives in frames where the V_L is being modulated for VPOS and VNEG or ii) tuned the intermediate gray tones with consideration of a lower voltage at the end of the drive. And

floating at the end of the low voltage drive may be achieved by using a high impedance switch on the VCOM_PANEL line to float the common electrode.

[0093] Referring now to FIGS. 15A-15C, which show a resulting shaped waveform in terms of optical performance and build-up of residual charge performance compared to the current default method of shorting at the end of the drive. In particular, FIG. 15A illustrates voltages across an electro-optic medium and optical trace using the waveform presented herein. FIG. 15B illustrates voltages across an electro-optic medium and optical trace with floating after an active drive. FIG. 15C illustrates voltage across an electro-optic medium and optical trace with shorting after an active drive.

[0094] FIG. 15D illustrates the build-up of residual charges of a DC-balanced white-to-white transition. The results show that the proposed method presented herein, when optimized properly, not only avoids optical kickback but also reduces build-up of residual charge as compared to the default method of shorting. Additionally, floating immediate after drive as shown in FIG. 15B and proposed by U.S. Patent No. 7,034,783, which is incorporated herein in its entirety, while avoiding optical kickback will possibly have deleterious effects on the display after prolonged usage due to the build-up of residual charge.

[0095] It will be apparent to those skilled in the art that numerous changes and modifications can be made to the specific embodiments of the invention described above without departing from the scope of the invention. Accordingly, the whole of the foregoing description is to be interpreted in an illustrative and not in a limitative sense.

CLAIMS

1. A method for driving an electro-optic display, the electro-optic display having a plurality of display pixels, wherein each of the plurality of display pixels is associated with a display transistor, the method comprising the following steps in order:
 - applying a first voltage to a first display transistor associated with a first display pixel of the plurality of display pixels, wherein the first voltage is applied during at least one frame of a driving waveform;
 - applying a second voltage to the first display transistor associated with the first display pixel,
 - wherein the second voltage has a non-zero amplitude less than the first voltage and is applied during the last frame of the driving waveform, and
 - wherein the amplitude of the second voltage is based on a voltage offset value and a sum of remnant voltages each frame of the driving waveform contributes to the first display pixel when the first voltage is applied to the first display transistor associated with the first display pixel.
2. The method of claim 1 wherein the duration of each frame of the driving waveform is substantially the same.
3. The method of claim 1 wherein the amplitude of the second voltage is further based on an amount of lightness of the first display pixel resulting from the driving waveform.
4. The method of claim 1 wherein the voltage offset value is based on a voltage contributed to the first display pixel due to a change in a gate voltage of the first display transistor and a parasitic capacitance of the first display transistor.
5. The method of claim 1 further comprising applying a third voltage to the first display transistor associated with the first display pixel, wherein the third voltage is substantially 0V.

6. The method of claim 1 wherein an amount of remnant voltage each frame of the driving waveform contributes to the first display pixel when the first voltage is applied to the first display transistor associated with the first display pixel is determined based on the amplitude of the first voltage and a remnant voltage coefficient corresponding to an amount of remnant voltage a frame of the driving waveform contributes to the display pixel.

7. The method of claim 6 further comprising determining the remnant voltage coefficients using an operational transconductance amplifier circuit model.

8. A method for driving a black-and-white electro-optic display to an optical rail state, the electro-optic display comprising an electrophoretic display medium electrically coupled between a plurality of display pixel electrodes and a common electrode, wherein each of the plurality of display pixel electrodes is associated with a display pixel, and wherein the electrophoretic display medium comprises a plurality of electrically charged black pigment particles and electrically charged white pigment particles, the method comprising the following steps in order:

connecting a first display transistor associated with a first display pixel of the plurality of display pixels to a first voltage driver circuit configured to provide a first voltage sufficient to drive the display pixel to an optical rail state, wherein the first voltage is provided during one or more frames of a driving waveform;

connecting the first display transistor associated with the first display pixel of the plurality of display pixels to a second voltage driver circuit configured to provide second voltage having a non-zero amplitude less than the first voltage for reducing an amount of remnant voltage the driving waveform contributes to the first display pixel, wherein the second voltage is provided after the one or more frames of the driving waveform; and

placing the first display pixel in a floating state.

9. The method of claim 8 wherein the optical rail state comprises one of a substantially black state or a substantially white state.

10. The method of claim 8 wherein the electrophoretic display medium comprises only the plurality of electrically charged black pigment particles and electrically charged white pigment particles.

11. The method of claim 8 wherein the second voltage is provided for a period of time longer in duration than each frame of the driving waveform.

12. The method of claim 8 wherein the second voltage is provided for a period of time shorter in duration than each frame of the driving waveform.

13. The method of claim 8 wherein connecting the first display transistor associated with the first display pixel of the plurality of display pixels to a first voltage driver circuit comprises setting a first switching device in electrical communication with the first voltage driver circuit and a display pixel electrode associated with the first display pixel to a closed state.

14. The method of claim 13 wherein connecting the first display transistor associated with the first display pixel of the plurality of display pixels to the second voltage driver circuit comprises:

setting the first switching device to an open state; and

setting a second switching device in electrical communication with the second voltage driver circuit and a display pixel electrode associated with the first display pixel to a closed state.

15. The method of claim 14 wherein placing the first display pixel in a floating state comprises setting the second switching device to an open state.

16. The method of claim 14 wherein placing the first display pixel in a floating state comprises disconnecting an electrical connection between the common electrode and a ground voltage.

17. The method of claim 8 wherein the first voltage and the second voltage have the same polarity.

18. The method of claim 8 wherein the amplitude of the second voltage and a duration of time the second voltage is provided are based on an amount of lightness of the optical rail state resulting from the driving waveform.

200

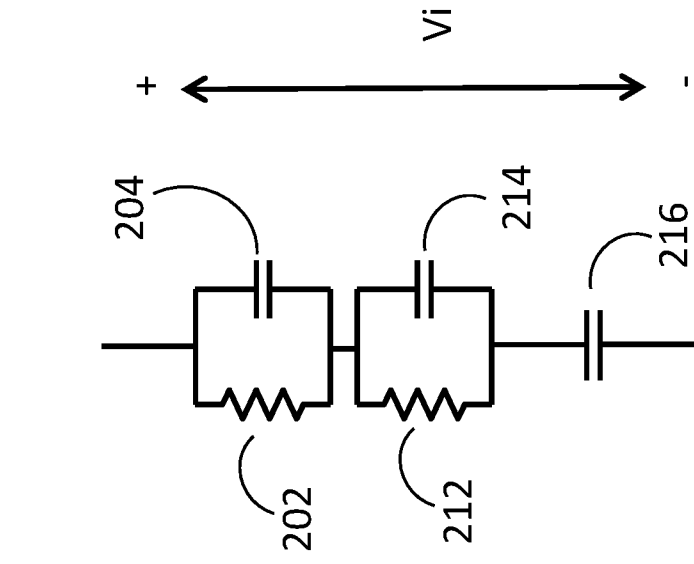

FIG. 2

100

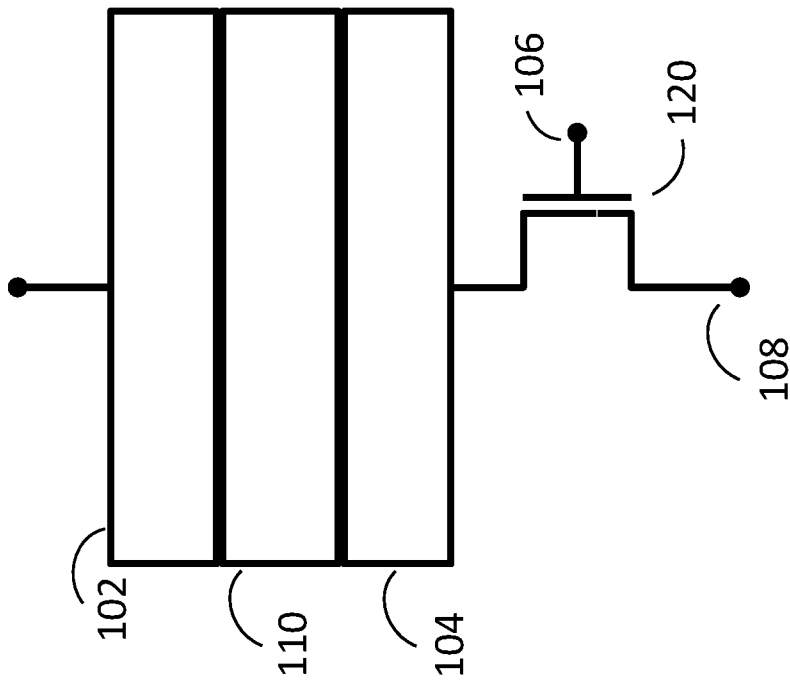

FIG. 1

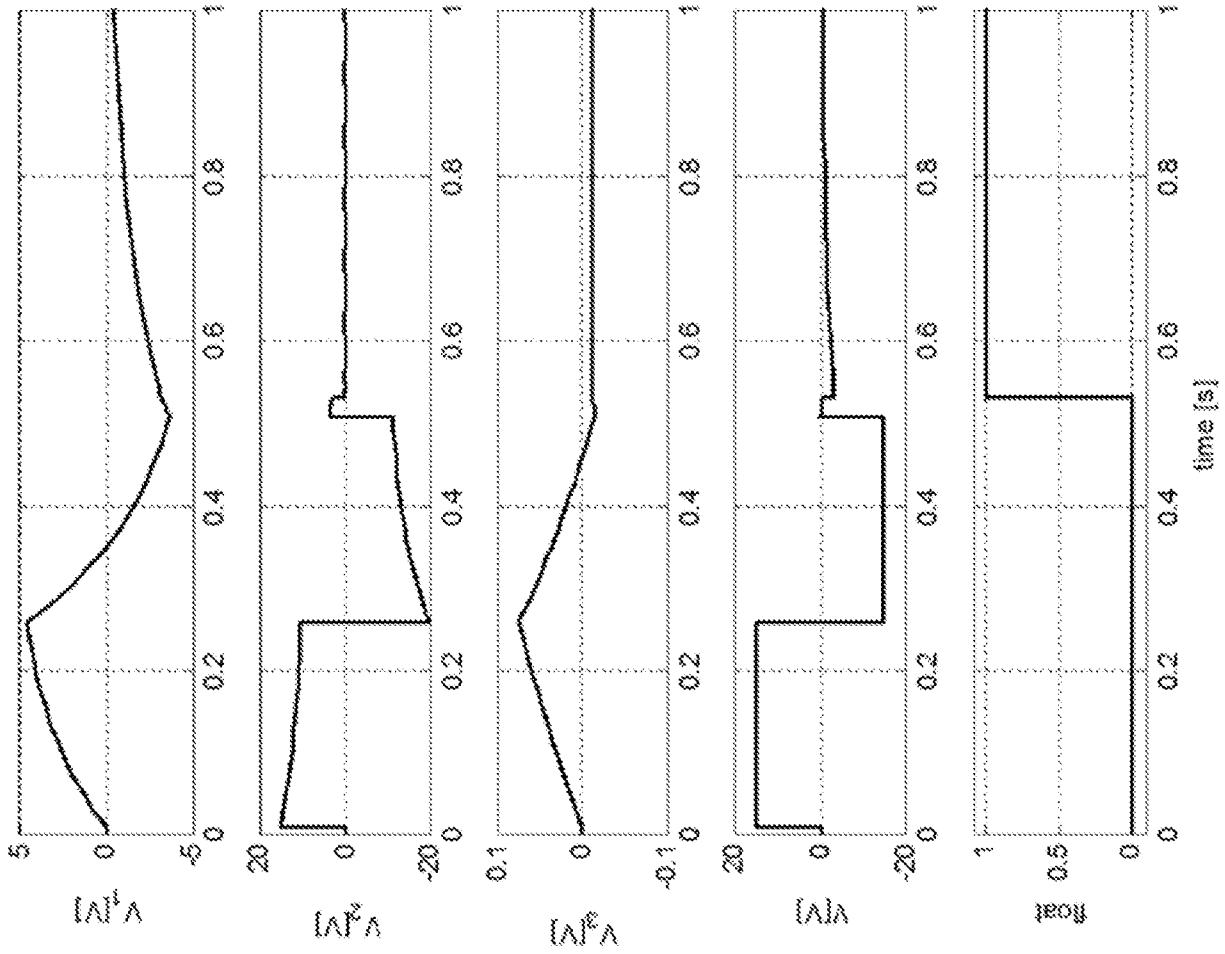

FIG. 3B

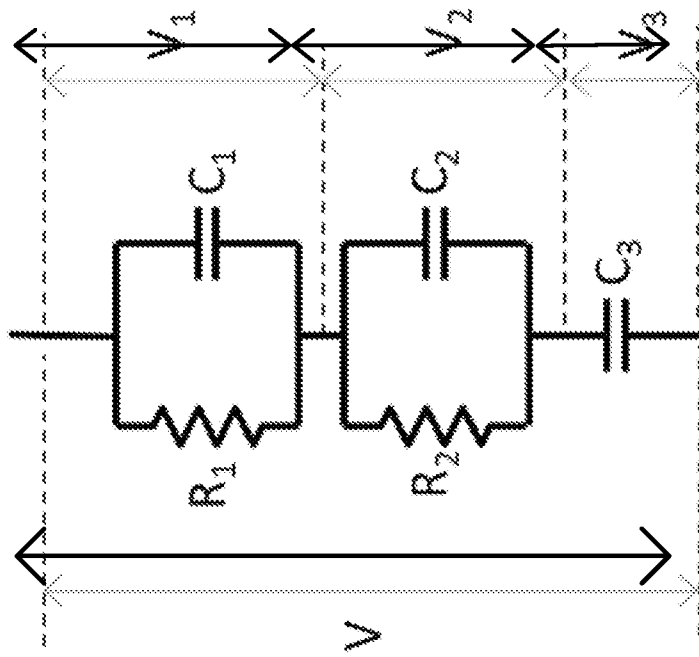

FIG. 3A

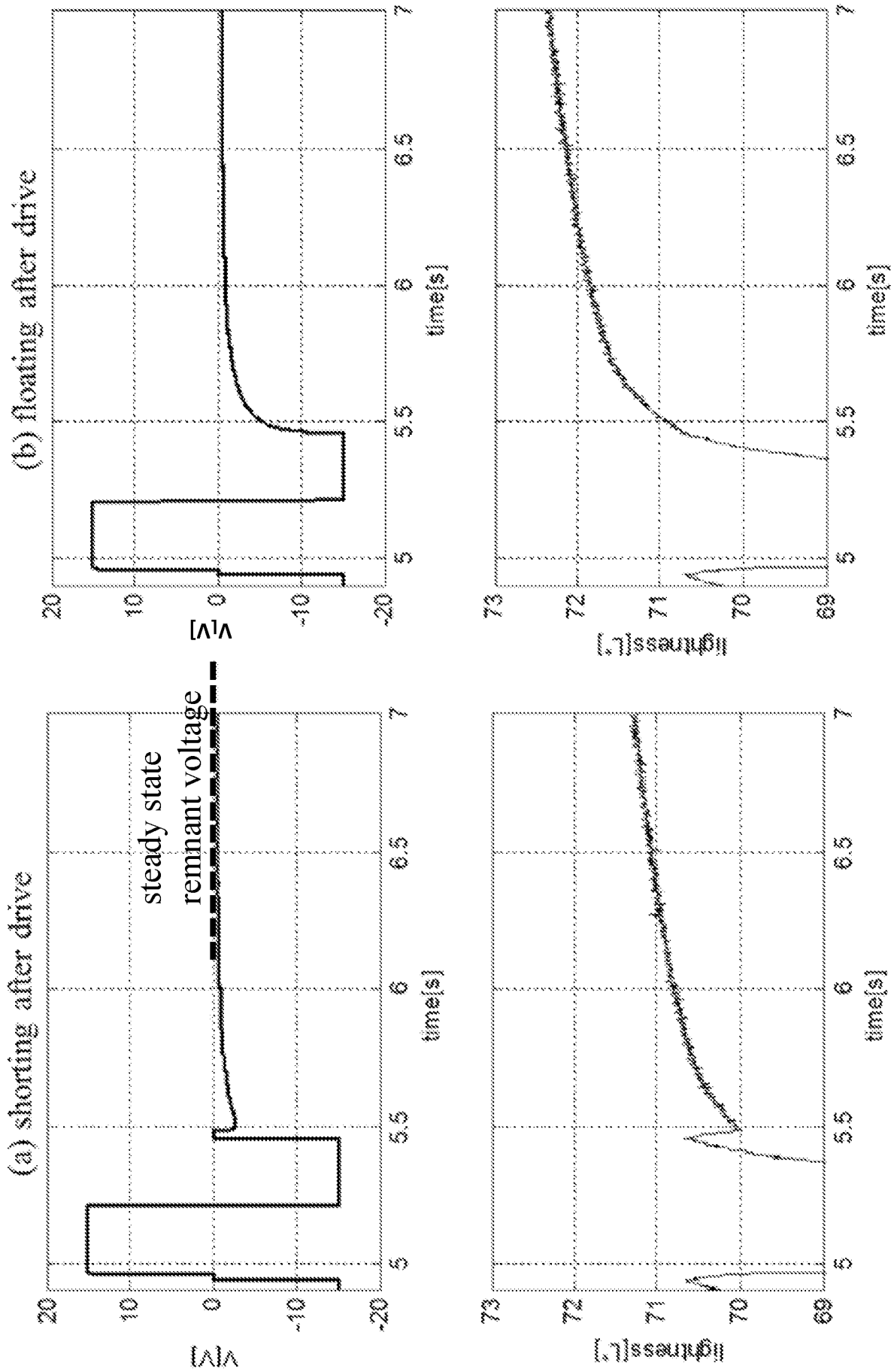

FIG. 4

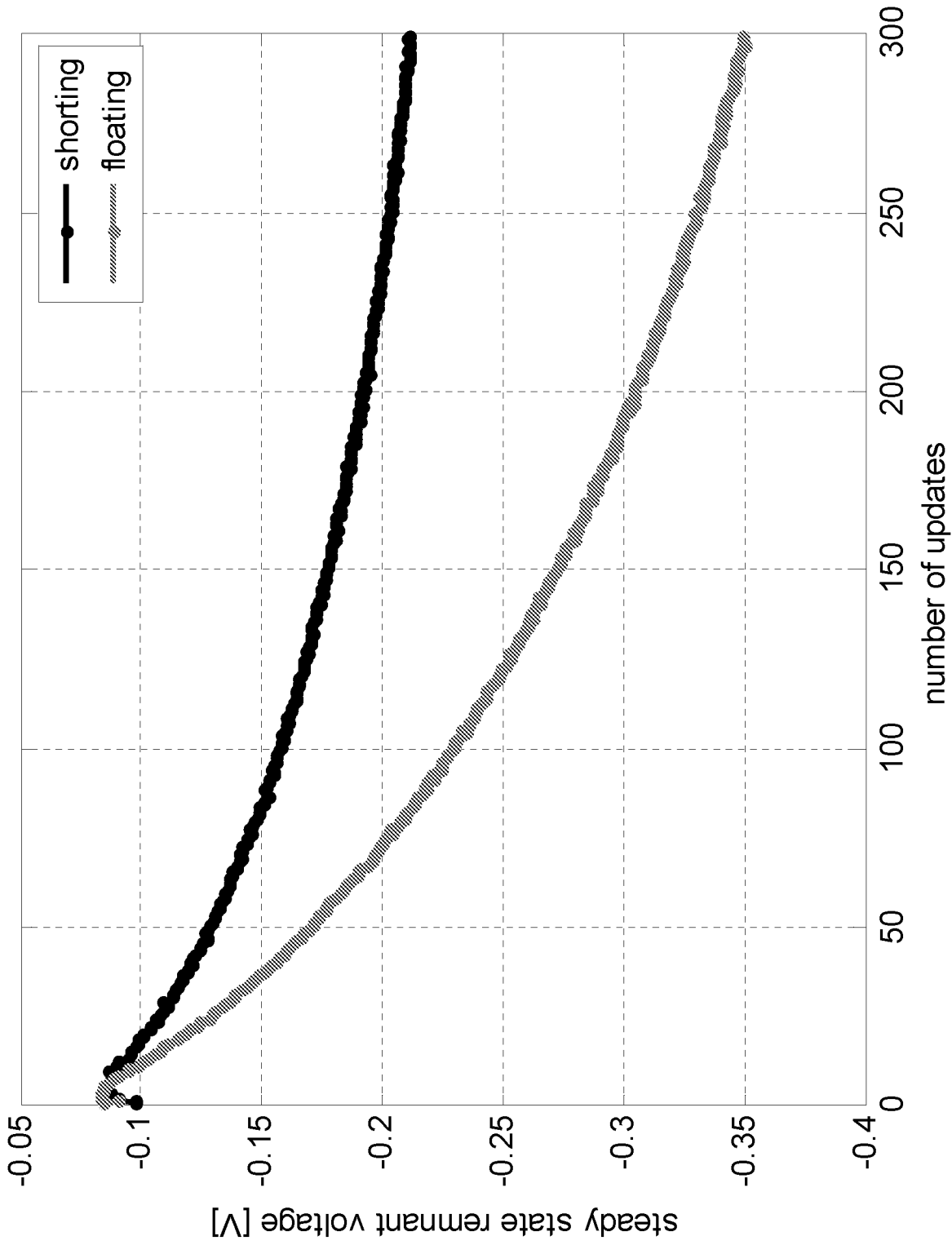

FIG. 5

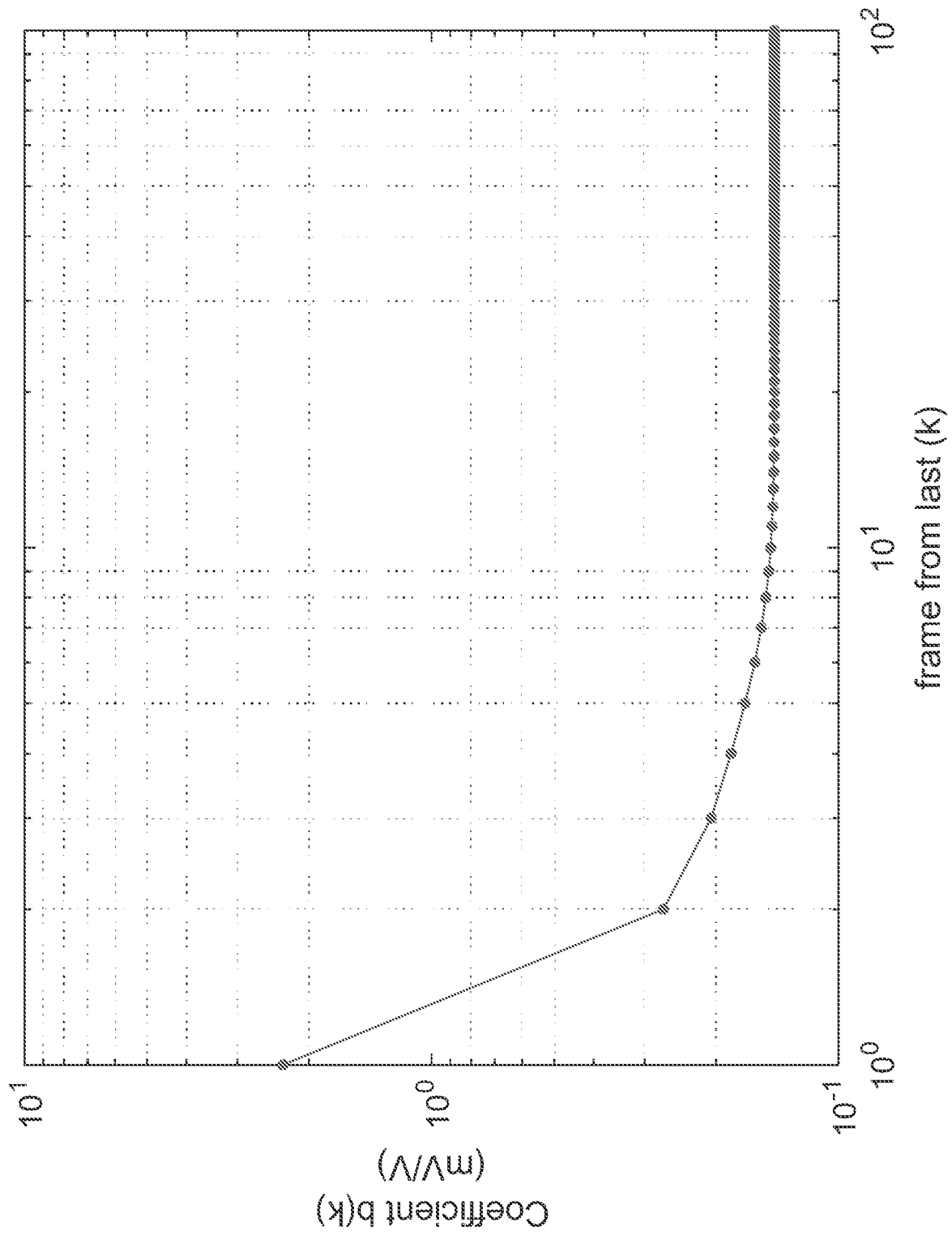

FIG. 6

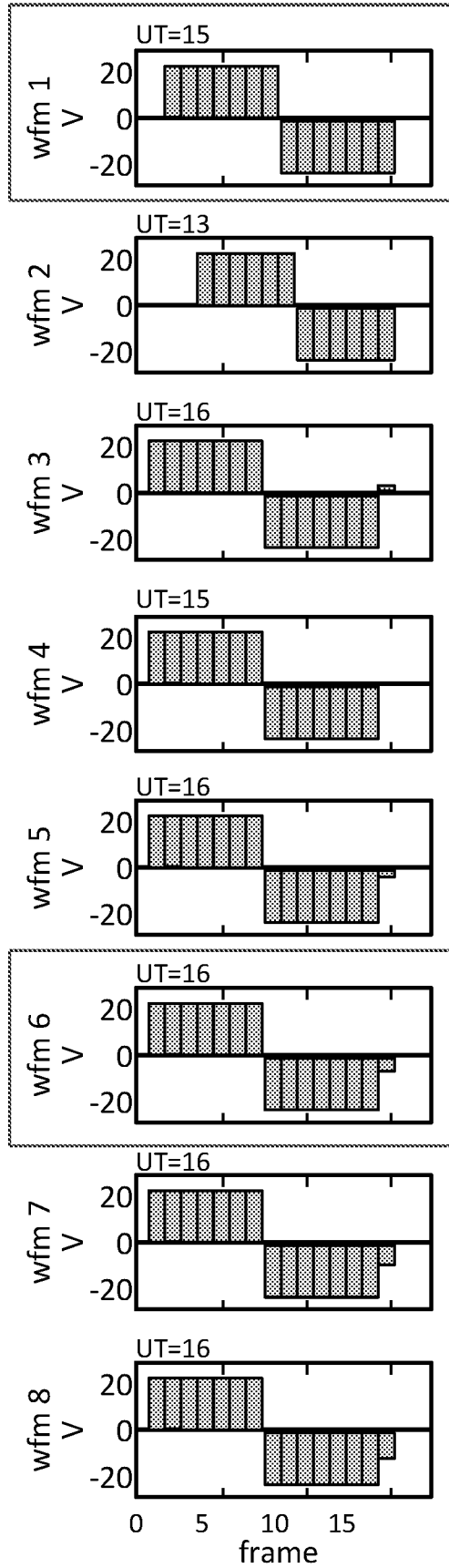
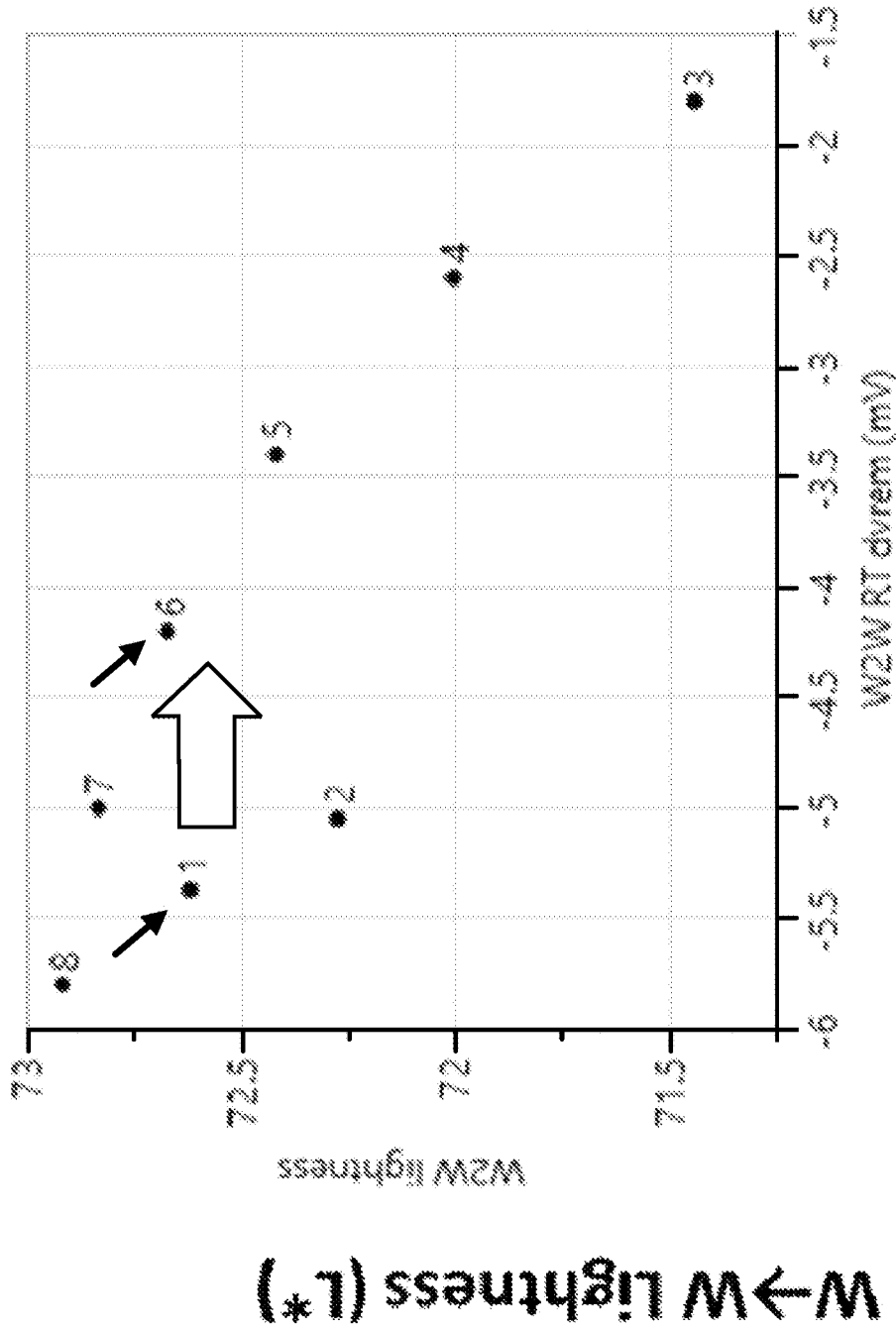

FIG. 7



W→W Remnant Voltage (mV)

FIG. 8

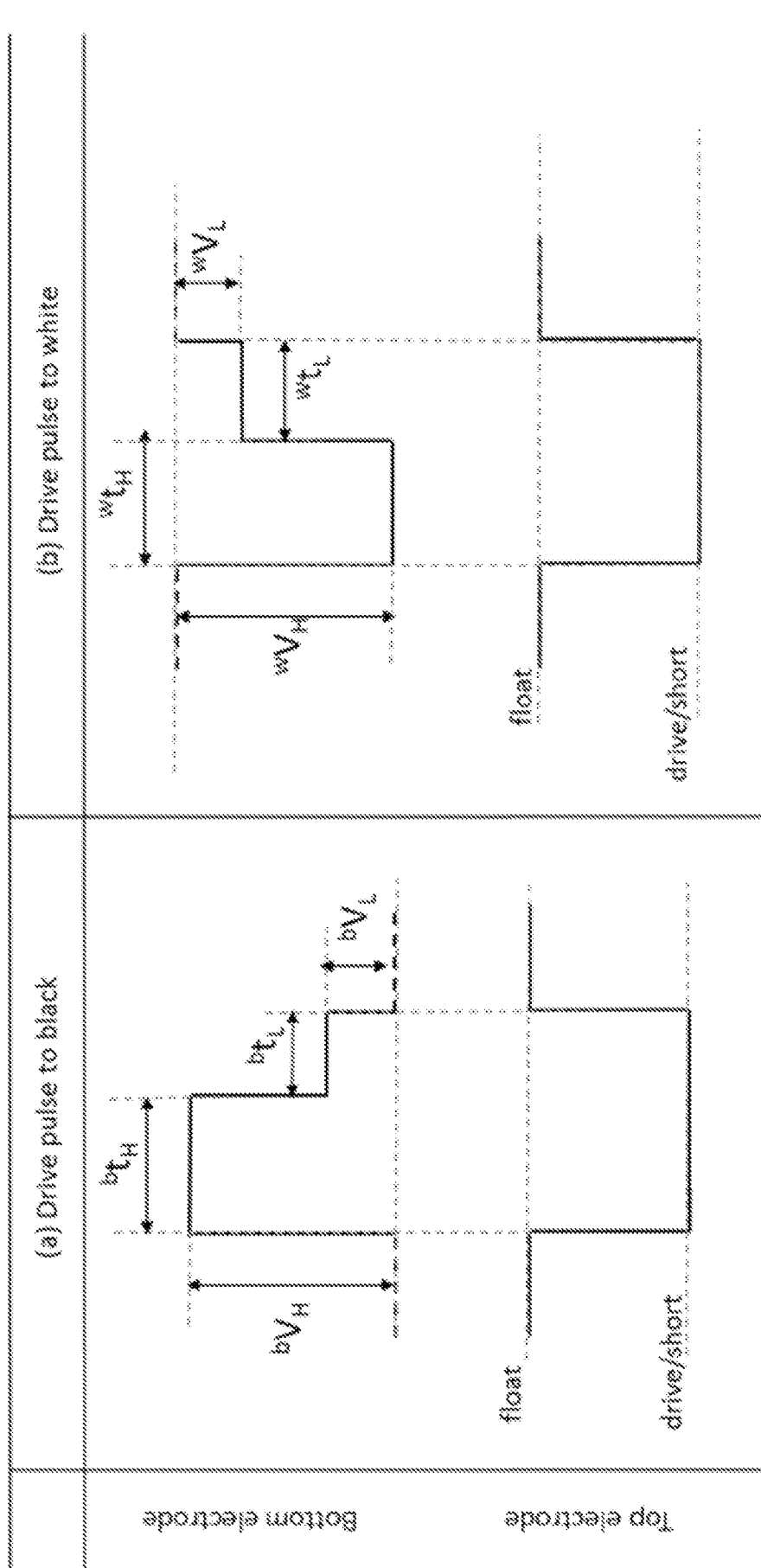
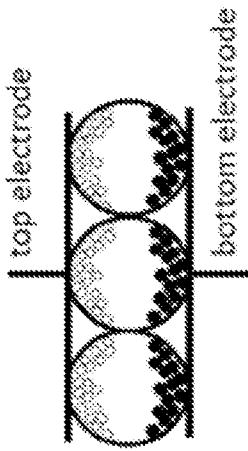

FIG. 9B

FIG. 9A

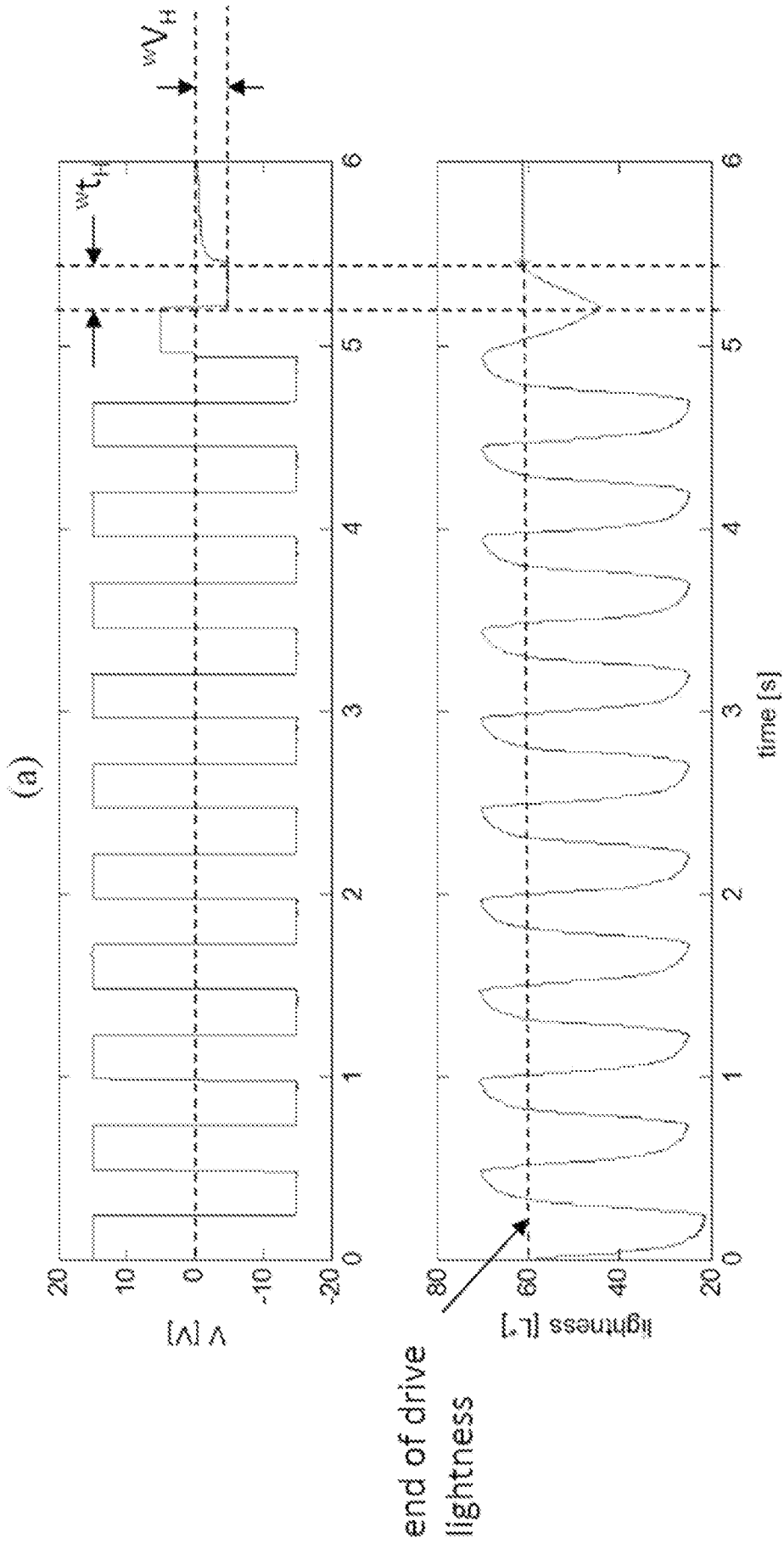

FIG. 10A

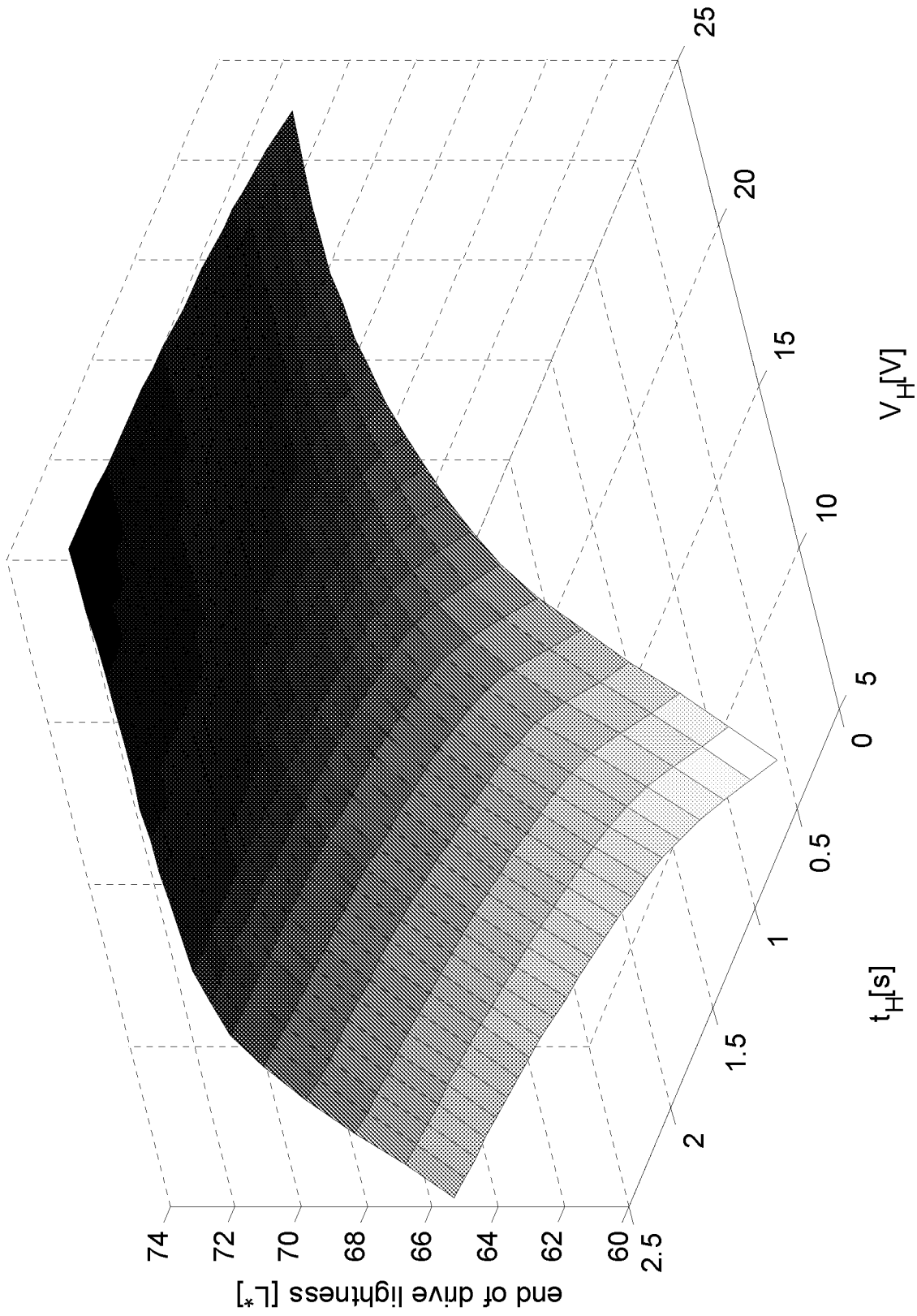
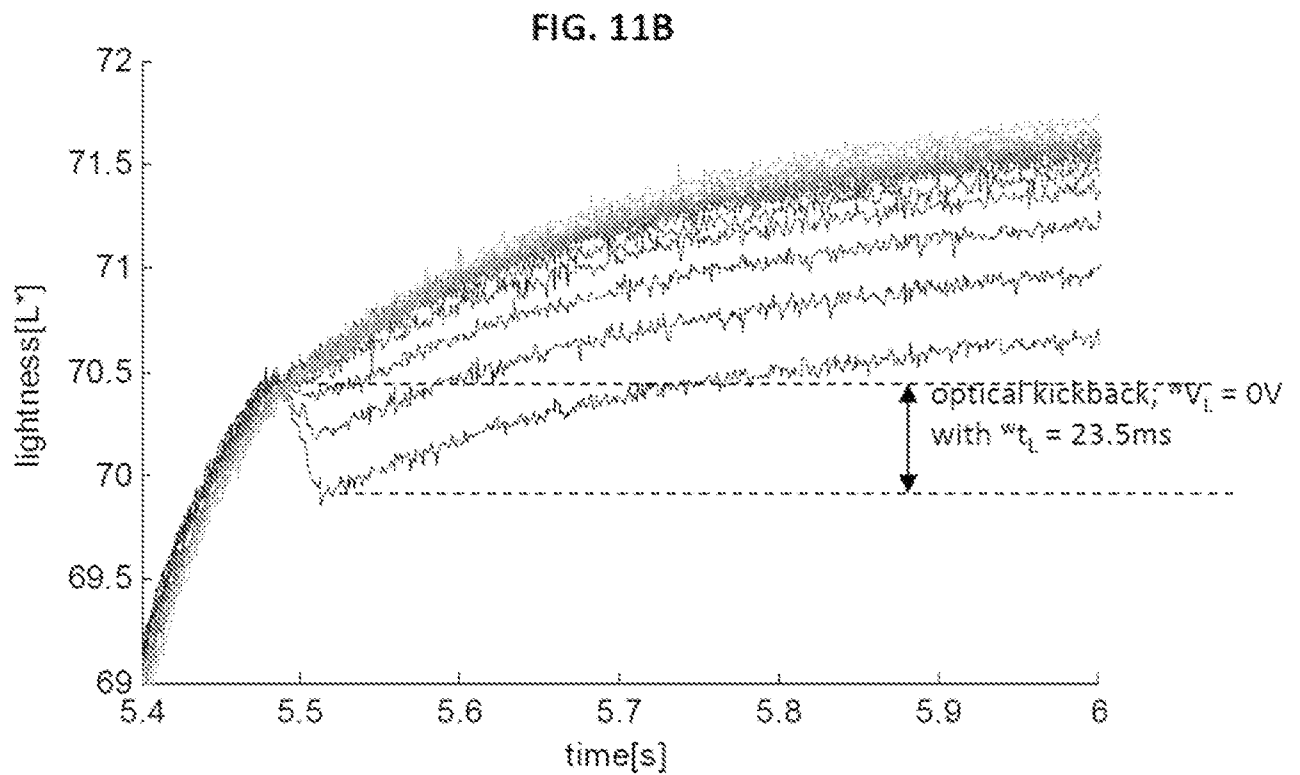
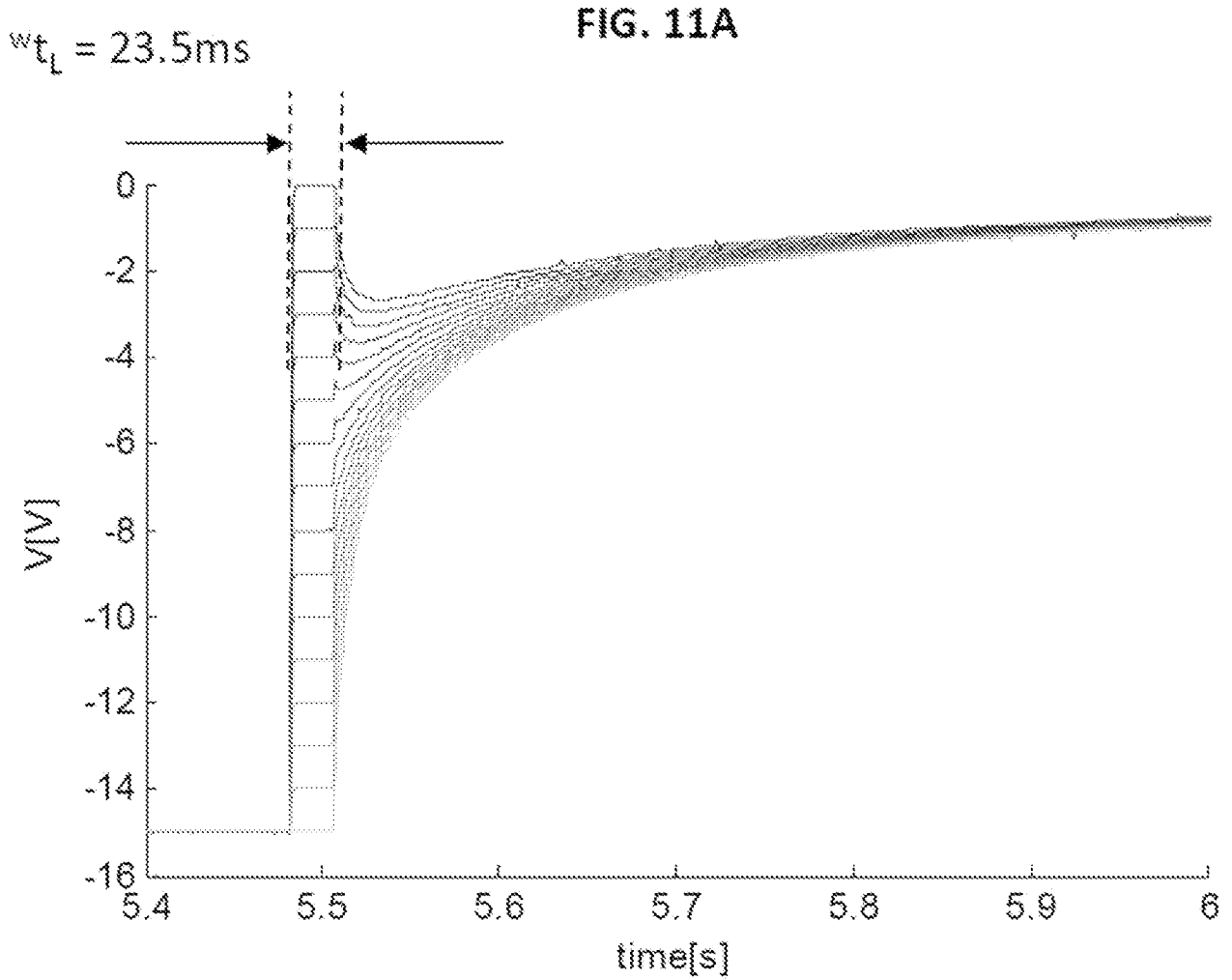

FIG. 10B



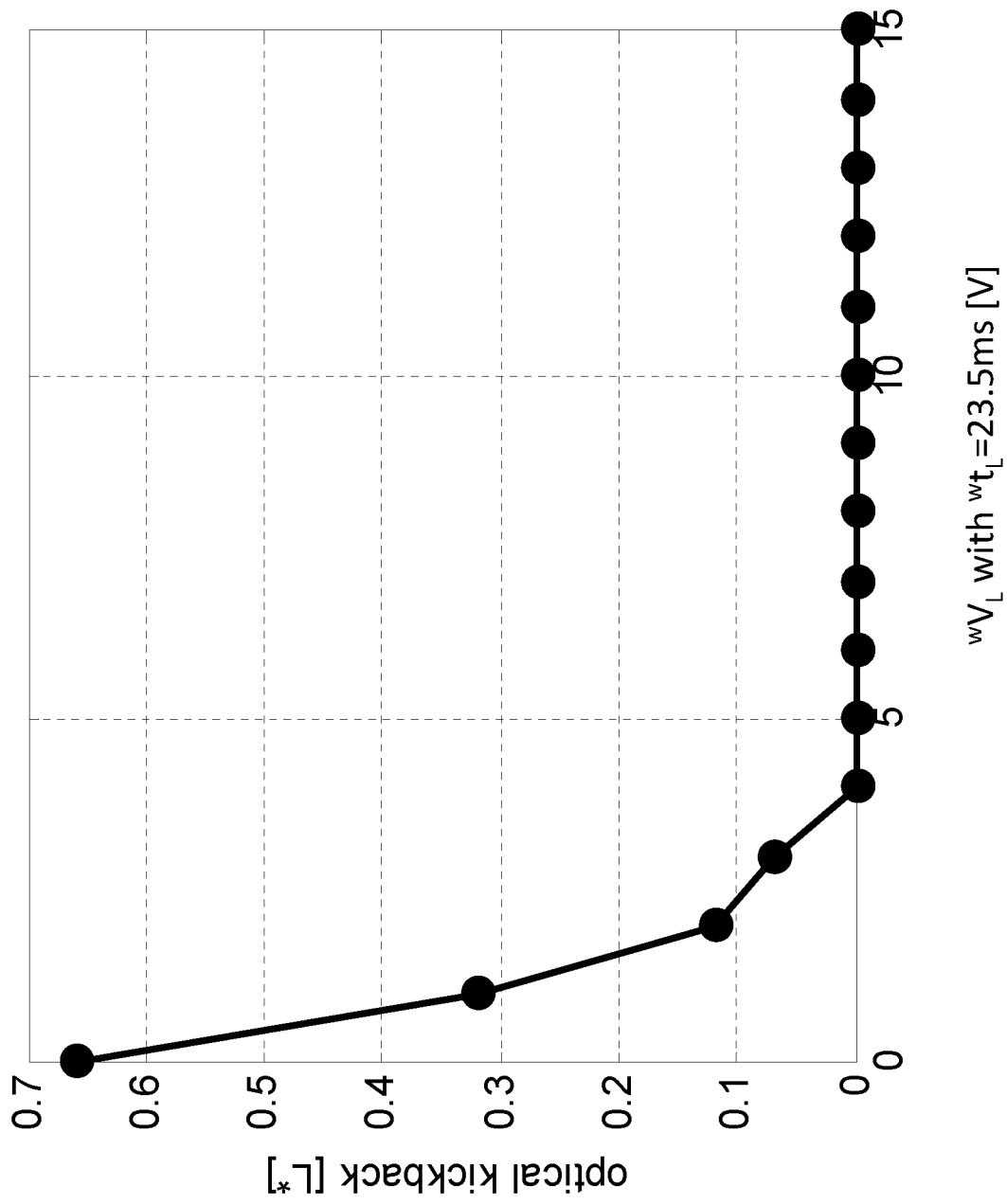

FIG. 11C

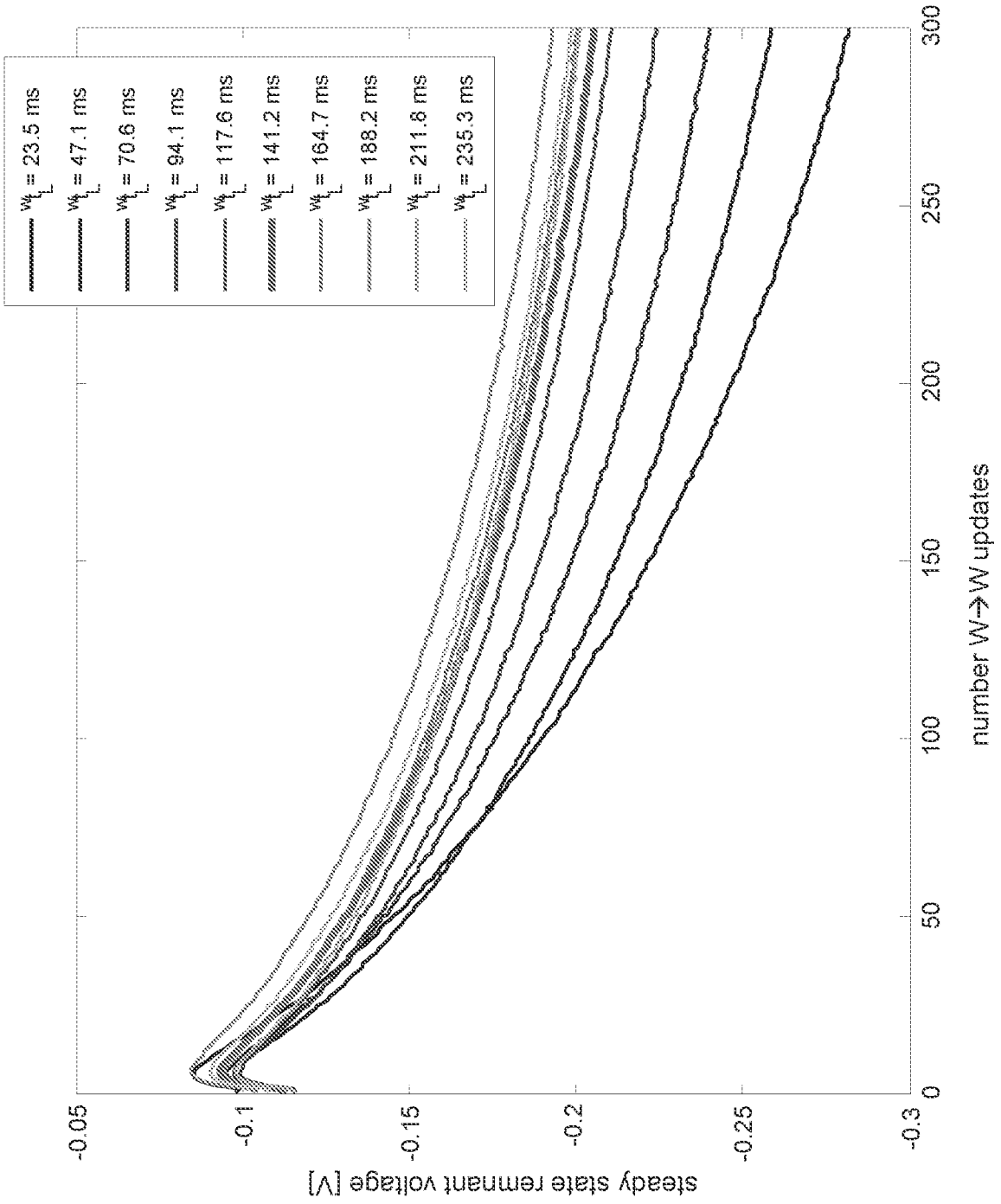

FIG. 12

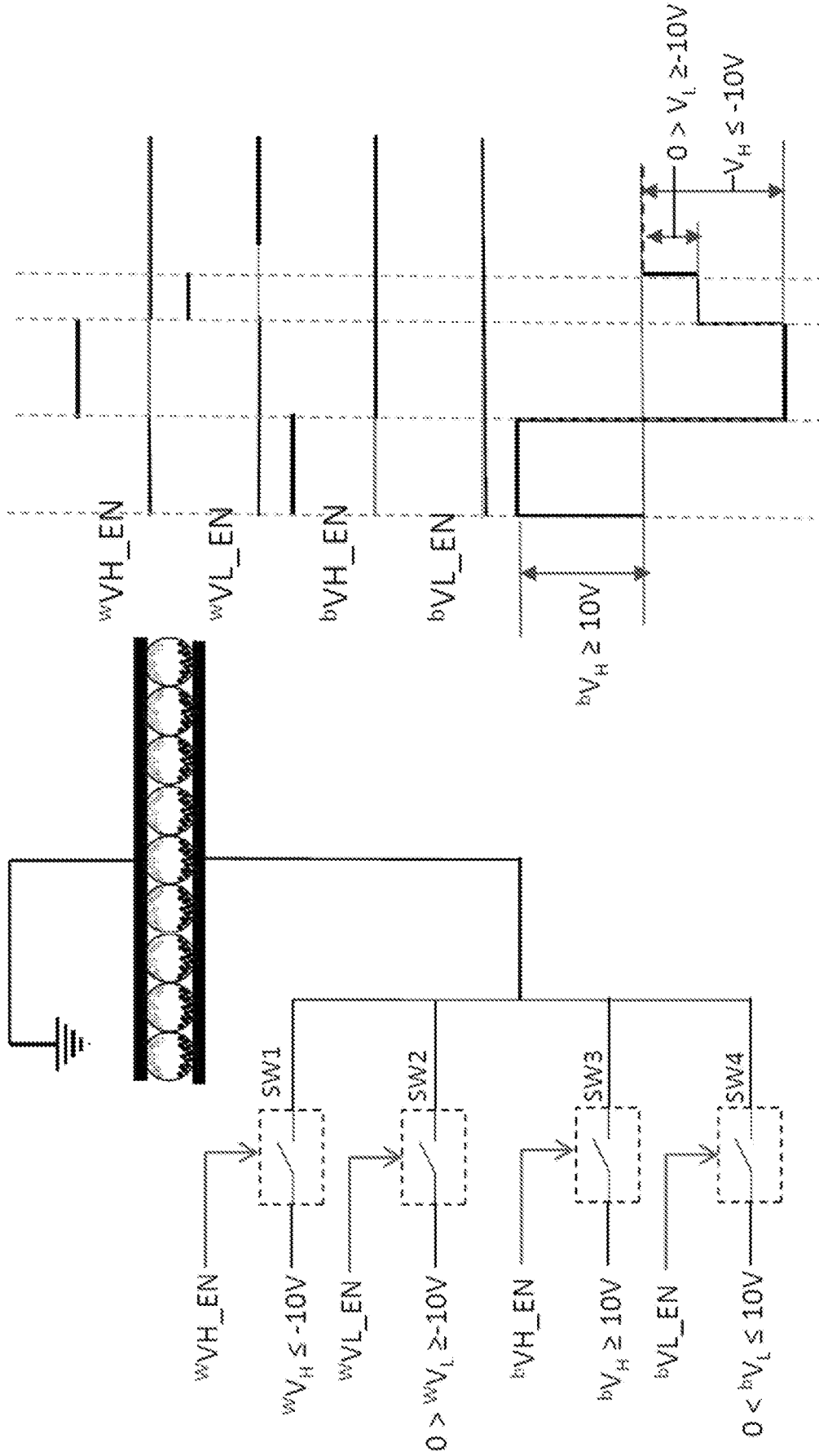

FIG. 13

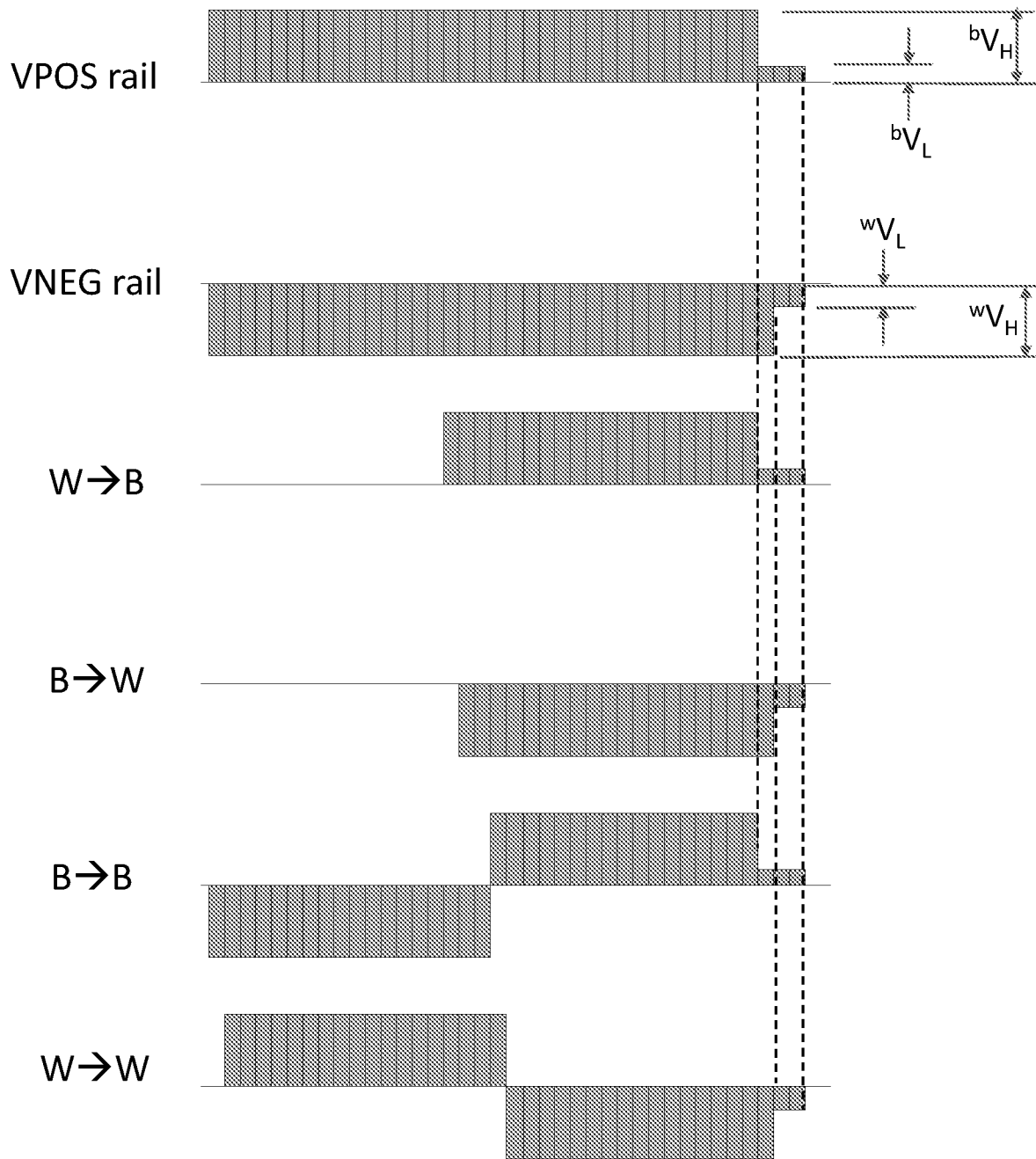

FIG. 14

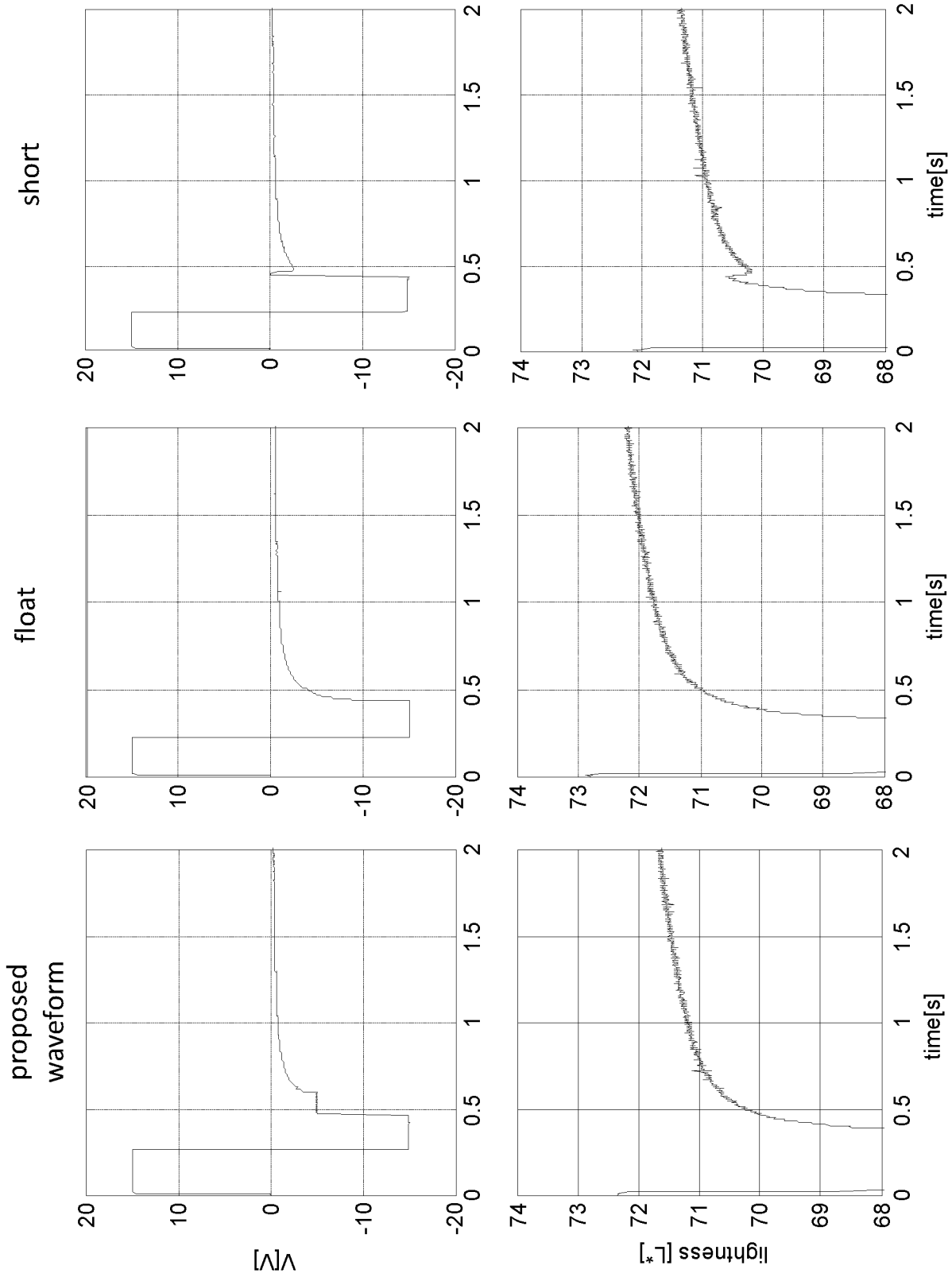

FIG. 15C

FIG. 15B

FIG. 15A

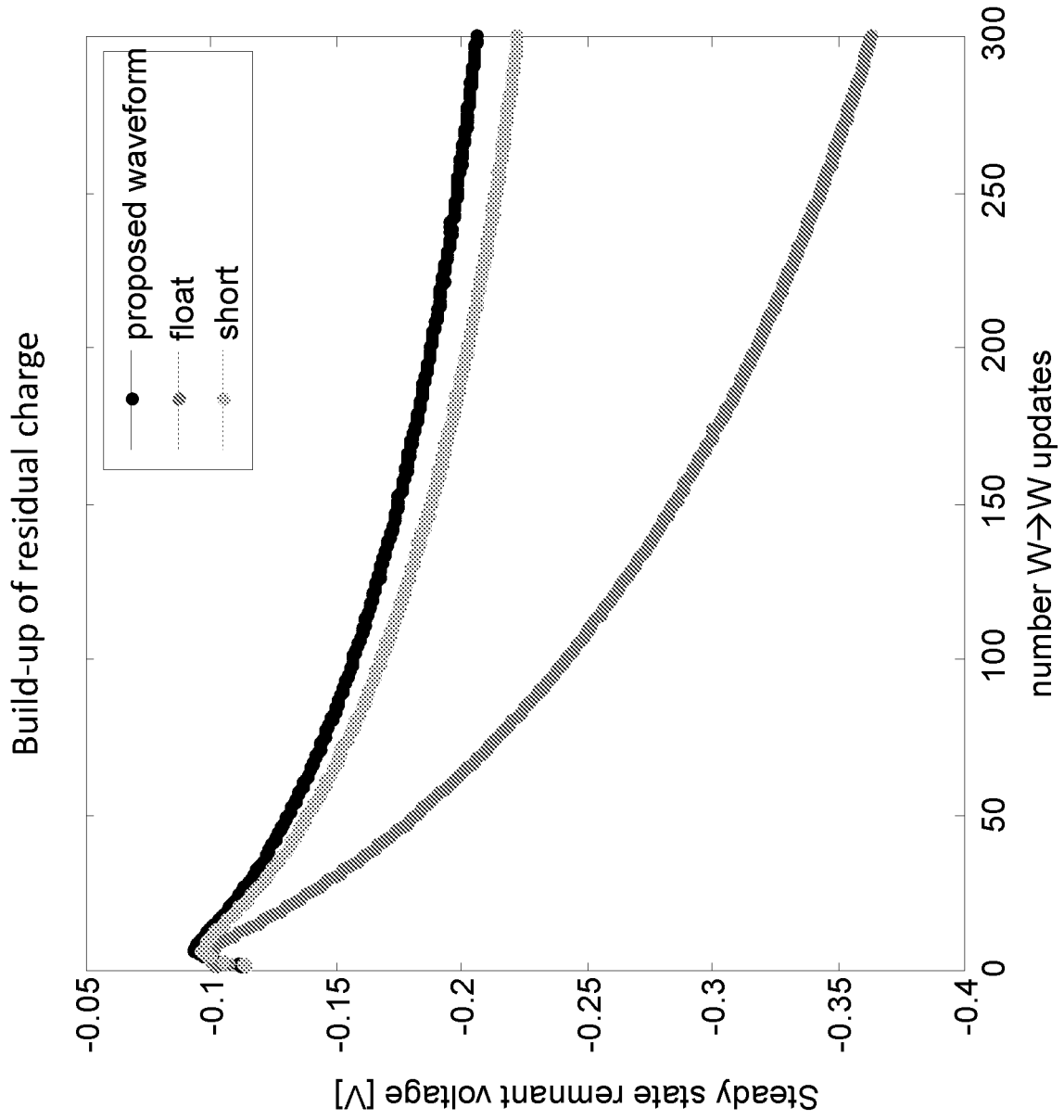

FIG. 15D

INTERNATIONAL SEARCH REPORT

International application No.

PCT/US2022/040697

A. CLASSIFICATION OF SUBJECT MATTER		
G02F 1/167(2006.01)i; G02F 1/16766(2019.01)i; G02F 1/1685(2019.01)i; G09G 3/34(2006.01)i		
According to International Patent Classification (IPC) or to both national classification and IPC		
B. FIELDS SEARCHED		
Minimum documentation searched (classification system followed by classification symbols) G02F 1/167(2006.01); G02F 1/1685(2019.01); G09G 3/20(2006.01); G09G 3/34(2006.01); G09G 5/00(2006.01)		
Documentation searched other than minimum documentation to the extent that such documents are included in the fields searched Korean utility models and applications for utility models Japanese utility models and applications for utility models		
Electronic data base consulted during the international search (name of data base and, where practicable, search terms used) eKOMPASS(KIPO internal) & Keywords: electro-optic display, pixel, transistor, first voltage, second voltage, voltage offset value, remnant voltage		
C. DOCUMENTS CONSIDERED TO BE RELEVANT		
Category*	Citation of document, with indication, where appropriate, of the relevant passages	Relevant to claim No.
Y	US 2020-0209703 A1 (E INK CALIFORNIA, LLC) 02 July 2020 (2020-07-02) paragraphs [0045]-[0049]; claims 1-2; and figure 1	8-12,17-18
A		1-7,13-16
Y	US 2005-0001812 A1 (KARL R. AMUNDSON et al.) 06 January 2005 (2005-01-06) paragraphs [0074]-[0077], [0322], [0532]-[0538]	8-12,17-18
A	US 2016-0225321 A1 (E INK CORPORATION) 04 August 2016 (2016-08-04) paragraphs [0072]-[0076]; and figure 3	1-18
A	US 2011-0012889 A1 (TSUTOMU MIYAMOTO) 20 January 2011 (2011-01-20) paragraphs [0058]-[0075]; and figures 1-5	1-18
A	JP 2011-248037 A (SEIKO EPSON CORP.) 08 December 2011 (2011-12-08) paragraphs [0013]-[0022]; and figures 1-3	1-18
<input type="checkbox"/> Further documents are listed in the continuation of Box C. <input checked="" type="checkbox"/> See patent family annex.		
* Special categories of cited documents: "A" document defining the general state of the art which is not considered to be of particular relevance "D" document cited by the applicant in the international application "E" earlier application or patent but published on or after the international filing date "L" document which may throw doubts on priority claim(s) or which is cited to establish the publication date of another citation or other special reason (as specified) "O" document referring to an oral disclosure, use, exhibition or other means "P" document published prior to the international filing date but later than the priority date claimed "T" later document published after the international filing date or priority date and not in conflict with the application but cited to understand the principle or theory underlying the invention "X" document of particular relevance; the claimed invention cannot be considered novel or cannot be considered to involve an inventive step when the document is taken alone "Y" document of particular relevance; the claimed invention cannot be considered to involve an inventive step when the document is combined with one or more other such documents, such combination being obvious to a person skilled in the art "&" document member of the same patent family		
Date of the actual completion of the international search 05 December 2022		Date of mailing of the international search report 05 December 2022
Name and mailing address of the ISA/KR Korean Intellectual Property Office 189 Cheongsa-ro, Seo-gu, Daejeon 35208, Republic of Korea Facsimile No. +82-42-481-8578		Authorized officer YANG, Jeong Rok Telephone No. +82-42-481-5709

INTERNATIONAL SEARCH REPORT
Information on patent family members

International application No.

PCT/US2022/040697

Patent document cited in search report			Publication date (day/month/year)	Patent family member(s)			Publication date (day/month/year)
US	2020-0209703	A1	02 July 2020	CA	3119532	A1	09 July 2020
				CN	113228151	A	06 August 2021
				EP	3903303	A1	03 November 2021
				JP	2022-512474	A	04 February 2022
				KR	10-2021-0084679	A	07 July 2021
				TW	202029153	A	01 August 2020
				TW	I734327	B	21 July 2021
				WO	2020-142399	A1	09 July 2020
US	2005-0001812	A1	06 January 2005	US	2003-0137521	A1	24 July 2003
				US	2006-0232531	A1	19 October 2006
				US	6504524	B1	07 January 2003
				US	6531997	B1	11 March 2003
				US	7012600	B2	14 March 2006
				US	7119772	B2	10 October 2006
				US	7733311	B2	08 June 2010
US	2016-0225321	A1	04 August 2016	CN	107223278	A	29 September 2017
				CN	107223278	B	28 May 2019
				CN	108028034	A	11 May 2018
				CN	108028034	B	04 June 2021
				CN	113241041	A	10 August 2021
				EP	3254276	A1	13 December 2017
				EP	3350798	A1	25 July 2018
				HK	1247729	A1	28 September 2018
				JP	2018-505446	A	22 February 2018
				JP	2018-529126	A	04 October 2018
				JP	2021-092821	A	17 June 2021
				JP	6613311	B2	27 November 2019
				JP	6871241	B2	12 May 2021
				KR	10-2017-0103870	A	13 September 2017
				KR	10-2018-0030949	A	26 March 2018
				KR	10-2020-0110475	A	23 September 2020
				KR	10-2061401	B1	31 December 2019
				KR	10-2158965	B1	23 September 2020
				KR	10-2308589	B1	01 October 2021
				TW	201640478	A	16 November 2016
				TW	201719616	A	01 June 2017
				TW	201810230	A	16 March 2018
				TW	I611393	B	11 January 2018
				TW	I637377	B	01 October 2018
				TW	I654594	B	21 March 2019
				US	10475396	B2	12 November 2019
				US	10803813	B2	13 October 2020
US	2017-0076672	A1	16 March 2017				
US	2020-0402469	A1	24 December 2020				
WO	2016-126771	A1	11 August 2016				
WO	2017-049020	A1	23 March 2017				
US	2011-0012889	A1	20 January 2011	CN	101958097	A	26 January 2011
				JP	2011-022497	A	03 February 2011
JP	2011-248037	A	08 December 2011	CN	102262856	A	30 November 2011

INTERNATIONAL SEARCH REPORT
Information on patent family members

International application No.

PCT/US2022/040697

Patent document cited in search report	Publication date (day/month/year)	Patent family member(s)	Publication date (day/month/year)
		CN 102262856 B	15 April 2015
		JP 5655371 B2	21 January 2015
		US 2011-0291708 A1	01 December 2011
		US 8564531 B2	22 October 2013
<hr/>			