

(12) **United States Patent**
Nau, Jr.

(10) **Patent No.:** **US 11,103,135 B2**
(45) **Date of Patent:** ***Aug. 31, 2021**

(54) **SURGICAL DEVICES AND METHODS UTILIZING OPTICAL COHERENCE TOMOGRAPHY (OCT) TO MONITOR AND CONTROL TISSUE SEALING**

(71) Applicant: **COVIDIEN LP**, Mansfield, MA (US)

(72) Inventor: **William H. Nau, Jr.**, Longmont, CO (US)

(73) Assignee: **Covidien LP**, Mansfield, MA (US)

(*) Notice: Subject to any disclaimer, the term of this patent is extended or adjusted under 35 U.S.C. 154(b) by 261 days.

This patent is subject to a terminal disclaimer.

(21) Appl. No.: **16/275,913**

(22) Filed: **Feb. 14, 2019**

(65) **Prior Publication Data**

US 2019/0175022 A1 Jun. 13, 2019

Related U.S. Application Data

(63) Continuation of application No. 14/052,827, filed on Oct. 14, 2013, now Pat. No. 10,206,583.
(Continued)

(51) **Int. Cl.**
A61B 5/00 (2006.01)
A61B 17/32 (2006.01)
(Continued)

(52) **U.S. Cl.**
CPC **A61B 5/0084** (2013.01); **A61B 5/0066** (2013.01); **A61B 18/1445** (2013.01);
(Continued)

(58) **Field of Classification Search**
None
See application file for complete search history.

(56) **References Cited**

U.S. PATENT DOCUMENTS

D249,549 S 9/1978 Pike
D263,020 S 2/1982 Rau, III
(Continued)

FOREIGN PATENT DOCUMENTS

CN 201299462 Y 9/2009
DE 2415263 A1 10/1975
(Continued)

OTHER PUBLICATIONS

Johannes de Boer et al., "Imaging Thermally Damaged Tissue by Polarization Sensitive Optical Coherence Tomography", *Optics Express*, Sep. 14, 1998, vol. 3, No. 6, pp. 212-218.

(Continued)

Primary Examiner — Katherine L Fernandez

Assistant Examiner — Colin T. Sakamoto

(74) *Attorney, Agent, or Firm* — Carter, DeLuca & Farrell LLP

(57) **ABSTRACT**

Surgical devices and methods for utilizing optical coherence tomography (OCT) to monitor and control tissue sealing are disclosed. The surgical device includes an end effector assembly that includes first and second jaw members that are movable between a first, spaced-apart position and a second proximate position. An OCT system, at least a portion of which is incorporated into the end effector assembly, is configured to sense properties of the tissue, e.g., the structural density of the tissue, disposed between the first and second jaw members. A tissue-sealing energy source may be disposed within at least one of the jaw members and may provide tissue-sealing energy to tissue disposed between the jaw members. A controller, which is coupled to the OCT system and the tissue-sealing energy source, controls the tissue-sealing energy generated by the tissue-sealing energy source based on the properties of the tissue sensed by the OCT system.

16 Claims, 9 Drawing Sheets

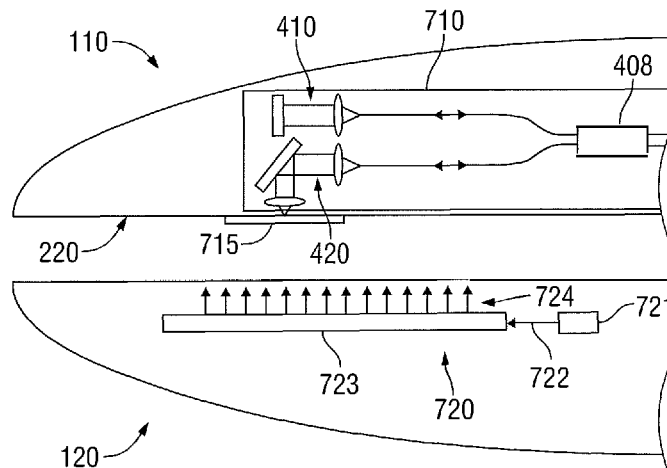

Related U.S. Application Data

- (60) Provisional application No. 61/720,817, filed on Oct. 31, 2012.
- (51) **Int. Cl.**
A61B 18/14 (2006.01)
A61B 18/00 (2006.01)
A61B 90/00 (2016.01)
- (52) **U.S. Cl.**
 CPC *A61B 2017/320093* (2017.08); *A61B 2017/320094* (2017.08); *A61B 2017/320095* (2017.08); *A61B 2018/0063* (2013.01); *A61B 2018/00642* (2013.01); *A61B 2090/3735* (2016.02)

D627,462	S	11/2010	Kingsley	
D628,289	S	11/2010	Romero	
D628,290	S	11/2010	Romero	
D630,324	S	1/2011	Reschke	
D649,249	S	11/2011	Guerra	
D649,643	S	11/2011	Allen, IV et al.	
D661,394	S	6/2012	Romero et al.	
10,206,583	B2*	2/2019	Nau, Jr.	A61B 5/0066
2002/0166946	A1	11/2002	Iizuka et al.	
2005/0203504	A1	9/2005	Wham et al.	
2006/0015165	A1	1/2006	Bertolero et al.	
2007/0055117	A1	3/2007	Alphonse	
2007/0197874	A1*	8/2007	Ishihara	A61B 5/1076 600/160
2007/0270792	A1	11/2007	Hennemann et al.	
2009/0177094	A1	7/2009	Brown et al.	
2011/0251605	A1*	10/2011	Hoarau	A61B 18/1233 606/34
2011/0279821	A1*	11/2011	Brennan	A61B 5/04001 356/479
2011/0282190	A1	11/2011	Caffey et al.	
2012/0253328	A1*	10/2012	Cunningham	A61L 2/00 606/1
2013/0345558	A1	12/2013	Boppart	
2015/0224326	A1	8/2015	Toth	

(56) **References Cited**

U.S. PATENT DOCUMENTS

D295,893	S	5/1988	Sharkany et al.
D295,894	S	5/1988	Sharkany et al.
D298,353	S	11/1988	Manno
D299,413	S	1/1989	DeCarolis
D343,453	S	1/1994	Noda
D348,930	S	7/1994	Olson
D349,341	S	8/1994	Lichtman et al.
D354,564	S	1/1995	Medema
D358,887	S	5/1995	Feinberg
D384,413	S	9/1997	Zlock et al.
5,772,597	A	6/1998	Goldberger et al.
H1745	H	8/1998	Paraschac
D402,028	S	12/1998	Grimm et al.
D408,018	S	4/1999	McNaughton
D416,089	S	11/1999	Barton et al.
D424,694	S	5/2000	Tetzlaff et al.
D425,201	S	5/2000	Tetzlaff et al.
H1904	H	10/2000	Yates et al.
6,201,608	B1	3/2001	Mandella
D449,886	S	10/2001	Tetzlaff et al.
6,343,227	B1	1/2002	Crowley
D453,923	S	2/2002	Olson
D454,951	S	3/2002	Bon
D457,958	S	5/2002	Dycus et al.
D457,959	S	5/2002	Tetzlaff et al.
H2037	H	7/2002	Yates et al.
D465,281	S	11/2002	Lang
D466,209	S	11/2002	Bon
6,485,413	B1	11/2002	Boppart et al.
D493,888	S	8/2004	Reschke
D496,997	S	10/2004	Dycus et al.
D499,181	S	11/2004	Dycus et al.
D502,994	S	3/2005	Blake, III
D509,297	S	9/2005	Wells
D525,361	S	7/2006	Hushka
D531,311	S	10/2006	Guerra et al.
D533,274	S	12/2006	Visconti et al.
D533,942	S	12/2006	Kerr et al.
D535,027	S	1/2007	James et al.
D538,932	S	3/2007	Malik
D541,418	S	4/2007	Schechter et al.
D541,611	S	5/2007	Aglassinger
D541,938	S	5/2007	Kerr et al.
D545,432	S	6/2007	Watanabe
D547,154	S	7/2007	Lee
D564,662	S	3/2008	Moses et al.
D567,943	S	4/2008	Moses et al.
D575,395	S	8/2008	Hushka
D575,401	S	8/2008	Hixson et al.
D582,038	S	12/2008	Swoyer et al.
D617,900	S	6/2010	Kingsley et al.
D617,901	S	6/2010	Unger et al.
D617,902	S	6/2010	Twomey et al.
D617,903	S	6/2010	Unger et al.
D618,798	S	6/2010	Olson et al.
D621,503	S	8/2010	Otten et al.

FOREIGN PATENT DOCUMENTS

DE	02514501	A1	10/1976
DE	2627679	A1	1/1977
DE	03423356	A1	1/1986
DE	03612646	A1	4/1987
DE	8712328	U1	2/1988
DE	04303882	C2	2/1995
DE	04403252	A1	8/1995
DE	19515914	C1	7/1996
DE	19506363	A1	8/1996
DE	29616210	U1	11/1996
DE	19608716	C1	4/1997
DE	19751106	A1	5/1998
DE	19738457	A1	3/1999
DE	19751108	A1	5/1999
DE	19946527	C1	7/2001
DE	10031773	A1	11/2001
DE	10045375	A1	4/2002
DE	20121161	U1	4/2002
DE	10249674	A1	5/2004
DE	202007009165	U1	8/2007
DE	202007009317	U1	8/2007
DE	202007009318	U1	8/2007
DE	202007016233	U1	1/2008
DE	102004026179	B4	1/2009
DE	102008018406	B3	7/2009
EP	1281878	A1	2/2003
EP	1159926	A2	3/2003
EP	2174613	A1	4/2010
EP	2241280	A2	10/2010
JP	61501068	A	5/1986
JP	6502328	A	3/1992
JP	55106	A	1/1993
JP	0540112	A	2/1993
JP	6121797	A	5/1994
JP	6285078	A	10/1994
JP	06343644	A	12/1994
JP	6511401	A	12/1994
JP	07265328	A	10/1995
JP	856955	A	5/1996
JP	08252263	A	10/1996
JP	8289895	A	11/1996
JP	8317934	A	12/1996
JP	8317936	A	12/1996
JP	910223	A	1/1997
JP	09000538	A	1/1997
JP	9122138	A	5/1997
JP	1024051	A	1/1998
JP	0010000195	A	1/1998
JP	10155798	A	6/1998
JP	1147150	A	2/1999

(56)

References Cited

FOREIGN PATENT DOCUMENTS

JP	11070124	A	3/1999
JP	11169381	A	6/1999
JP	11192238	A	7/1999
JP	11244298	A	9/1999
JP	2000102545	A	4/2000
JP	2000135222	A	5/2000
JP	2000342599	A	12/2000
JP	2000350732	A	12/2000
JP	2001003400	A	1/2001
JP	2001008944	A	1/2001
JP	2001029356	A	2/2001
JP	2001128990	A	5/2001
JP	2001190564	A	7/2001
JP	2002136525	A	5/2002
JP	2002528166	A	9/2002
JP	2003116871	A	4/2003
JP	2003175052	A	6/2003
JP	2003245285	A	9/2003
JP	2004517668	A	6/2004
JP	2004528869	A	9/2004
JP	2005152663	A	6/2005
JP	2005253789	A	9/2005
JP	2006015078	A	1/2006
JP	2006501939	A	1/2006
JP	2006095316	A	4/2006
JP	2011125195	A	6/2011
JP	0006030945	B2	11/2016
SU	401367	A1	10/1973
WO	0036986	A1	6/2000
WO	0059392	A1	10/2000
WO	0115614	A1	3/2001
WO	0154604	A1	8/2001
WO	0245589	A2	6/2002
WO	2006021269	A1	3/2006
WO	2005110264	A2	4/2006
WO	2008040483	A1	4/2008
WO	20090005850	A1	1/2009
WO	2011018154	A1	2/2011

OTHER PUBLICATIONS

Michael Choti, "Abdominoperineal Resection with the LigaSure Vessel Sealing System and LigaSure Atlas 20 cm Open Instrument" *Innovations That Work*, Jun. 2003.

Chung et al., "Clinical Experience of Sutureless Closed Hemorrhoidectomy with LigaSure" *Diseases of the Colon & Rectum* vol. 46, No. 1 Jan. 2003.

Tinkler L.F., "Combined Diathermy and Suction Forceps", Feb. 6, 1967 (Feb. 6, 1965), *British Medical Journal* Feb. 6, 1976, vol. 1, nr. 5431 p. 361, ISSN: 0007-1447.

Carbonell et al., "Comparison of the Gyros PlasmaKinetic Sealer and the Valleylab LigaSure Device in the Hemostasis of Small, Medium, and Large-Sized Arteries" *Carolinas Laparoscopic and Advanced Surgery Program*, Carolinas Medical Center, Charlotte, NC; Date: Aug. 2003.

Peterson et al., "Comparison of Healing Process Following Ligation with Sutures and Bipolar Vessel Sealing" *Surgical Technology International* (2001).

"Electrosurgery: A Historical Overview" *Innovations in Electrosurgery*; Sales-Product Literature; Dec. 31, 2000.

Johnson et al. "Evaluation of a Bipolar Electrothermal Vessel Sealing Device in Hemorrhoidectomy" *Sales/Product Literature*; Jan. 2004.

E. David Crawford, "Evaluation of a New Vessel Sealing Device in Urologic Cancer Surgery" *Sales/Product Literature* 2000.

Johnson et al. "Evaluation of the LigaSure Vessel Sealing System in Hemorrhoidectomy" *American College of Surgeons (ACS) Clinica Congress Poster* (2000).

Muller et al. "Extended Left Hemicolectomy Using the LigaSure Vessel Sealing System" *Innovations That Work*; Sep. 1999.

Kennedy et al. "High-burst-strength, feedback-controlled bipolar vessel sealing" *Surgical Endoscopy* (1998) 12:876-878.

Burdette et al. "In Vivo Probe Measurement Technique for Determining Dielectric Properties at VHF Through Microwave Frequencies", *IEEE Transactions on Microwave Theory and Techniques*, vol. MTT-28, No. 4, Apr. 1980 pp. 414-427.

Carus et al., "Initial Experience With the LigaSure Vessel Sealing System in Abdominal Surgery" *Innovations That Work*, Jun. 2002.

Heniford et al. "Initial Research and Clinical Results with an Electrothermal Bipolar Vessel Sealer" Oct. 1999.

Heniford et al. "Initial Results with an Electrothermal Bipolar Vessel Sealer" *Surgical Endoscopy* (2000) 15:799-801.

Herman et al., "Laparoscopic Intestinal Resection With the LigaSure Vessel Sealing System: A Case Report"; *Innovations That Work*, Feb. 2002.

Koyle et al., "Laparoscopic Palomo Varicocele Ligation in Children and Adolescents" *Pediatric Endosurgery & Innovative Techniques*, vol. 6, No. 1, 2002.

W. Scott Helton, "LigaSure Vessel Sealing System: Revolutionary Hemostasis Product for General Surgery"; *Sales/Product Literature* 1999.

LigaSure Vessel Sealing System, the Seal of Confidence in General, Gynecologic, Urologic, and Laparoscopic Surgery; *Sales/Product Literature*; Apr. 2002.

Joseph Ortenberg "LigaSure System Used in Laparoscopic 1st and 2nd Stage Orchiopexy" *Innovations That Work*, 2002.

Sigel et al., "The Mechanism of Blood Vessel Closure by High Frequency Electrocoagulation" *Surgery Gynecology & Obstetrics*, Oct. 1965 pp. 823-831.

Sampayan et al., "Multilayer Ultra-High Gradient Insulator Technology" *Discharges and Electrical Insulation in Vacuum*, 1998. Netherlands Aug. 17-21, 1998; vol. 2, pp. 740-743.

Paul G. Horgan, "A Novel Technique for Parenchymal Division During Hepatectomy" *The American Journal of Surgery*, vol. 181, No. 3, Apr. 2001 pp. 236-237.

Benaron et al., "Optical Time-Of-Flight and Absorbance Imaging of Biologic Media", *Science, American Association for the Advancement of Science*, Washington, DC, vol. 259, Mar. 5, 1993, pp. 1463-1466.

Olsson et al. "Radical Cystectomy in Females". *Current Surgical Techniques in Urology*, vol. 14, Issue 3, 2001.

Palazzo et al. "Randomized clinical trial of Ligasure versus open haemorrhoidectomy" *British Journal of Surgery* 2002, 89, 154-157.

Levy et al. "Randomized Trial of Suture Versus Electrosurgical Bipolar Vessel Sealing in Vaginal Hysterectomy" *Obstetrics & Gynecology*, vol. 102, No. 1, Jul. 2003.

Bergdahl et al., "Studies on Coagulation and the Development of an Automatic Computerized Bipolar Coagulator" *J. Neurosurg*, vol. 75, Jul. 1991, pp. 148-151.

Strasberg et al. "A Phase I Study of the LigaSure Vessel Sealing System in Hepatic Surgery" *Section of HPB Surger, Washington University School of Medicine, St. Louis MO*, Presented at AHPBA, Feb. 2001.

Sayfan et al., "Sutureless Closed Hemorrhoidectomy: A New Technique" *Annals of Surgery*, vol. 234, No. 1, Jul. 2001, pp. 21-24.

Levy et al., "Update on Hysterectomy—New Technologies and Techniques" *OBG Management*, Feb. 2003.

Dulemba et al. "Use of a Bipolar Electrothermal Vessel Sealer in Laparoscopically Assisted Vaginal Hysterectomy" *Sales/Product Literature*; Jan. 2004.

Sengupta et al., "Use of a Computer-Controlled Bipolar Diathermy System in Radical Prostatectomies and Other Open Urological Surgery" *ANZ Journal of Surgery* (2001) 71.9 pp. 538-540.

Rothenberg et al. "Use of the LigaSure Vessel Sealing System in Minimally Invasive Surgery in Children" *Int'l Pediatric Endosurgery Group (IPEG)* 2000.

Crawford et al. "Use of the LigaSure Vessel Sealing System in Urologic Cancer Surgery"; *Grand Rounds in Urology* 1999 vol. 1 Issue 4 pp. 10-17.

Craig Johnson, "Use of the LigaSure Vessel Sealing System in Bloodless Hemorrhoidectomy"; *Innovations That Work*, Mar. 2000.

(56)

References Cited

OTHER PUBLICATIONS

Levy et al. "Use of a New Energy-based Vessel Ligation Device During Vaginal Hysterectomy"; Int'l Federation of Gynecology and Obstetrics (FIGO) World Congress 1999.

Barbara Levy, "Use of a New Vessel Ligation Device During Vaginal Hysterectomy" FIGO 2000, Washington, D.C.

E. David Crawford, "Use of a Novel Vessel Sealing Technology in Management of the Dorsal Veinous Complex" Sales/Product Literature 2000.

Jarrett et al., "Use of the LigaSure Vessel Sealing System for Peri-Hilar Vessels in Laparoscopic Nephrectomy"; Sales/Product Literature 2000.

Crouch et al. "A Velocity-Dependent Model for Needle Insertion in Soft Tissue"; MICCAI 2005; LNCS 3750 pp. 624-632, Dated: 2005.

McLellan et al., "Vessel Sealing for Hemostasis During Pelvic Surgery" Int'l Federation of Gynecology and Obstetrics FIGO World Congress 2000, Washington, DC.

McLellan et al. "Vessel Sealing for Hemostasis During Gynecologic Surgery" Sales/Product Literature 1999.

"Reducing Needlestick Injuries in the Operating Room"; Sales/Product Literature 2001.

Strasberg et al., "Use of a Bipolar Vessel-Sealing Device for Parenchymal Transection During Liver Surgery" Journal of Gastrointestinal Surgery, vol. 6, No. 4, Jul./Aug. 2002 pp. 569-574.

European Search Report dated Oct. 10, 2016, issued in EP Application No. 16176334.7.

* cited by examiner

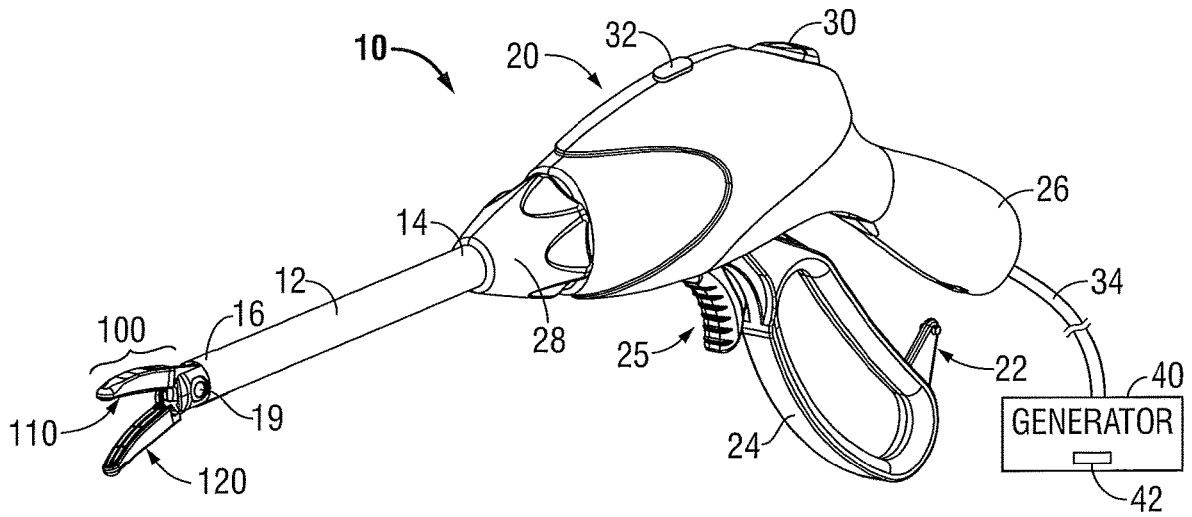

FIG. 1A

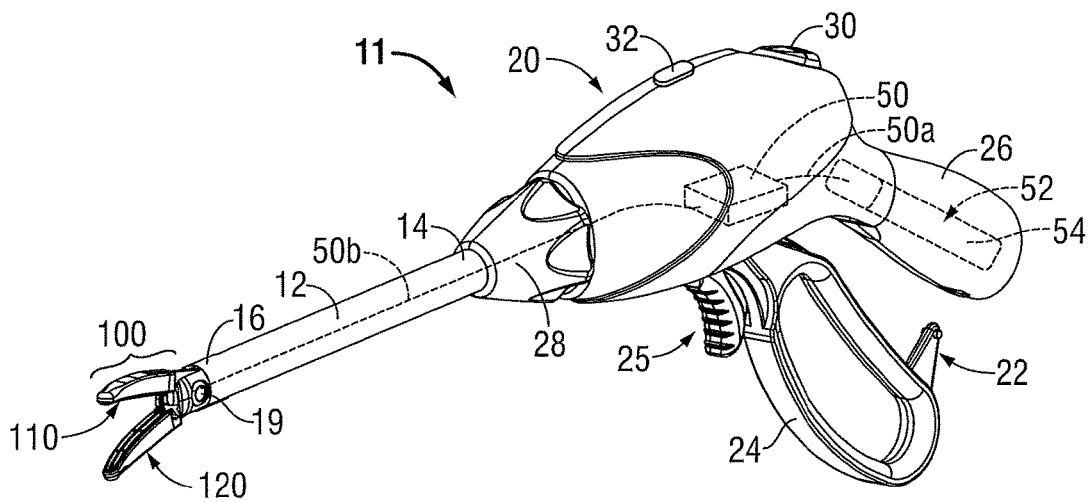

FIG. 1B

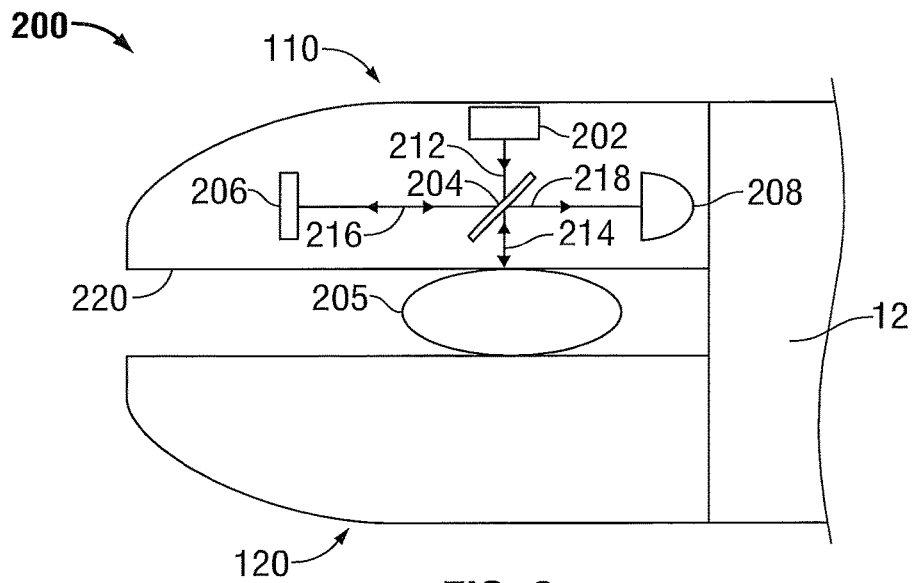

FIG. 2

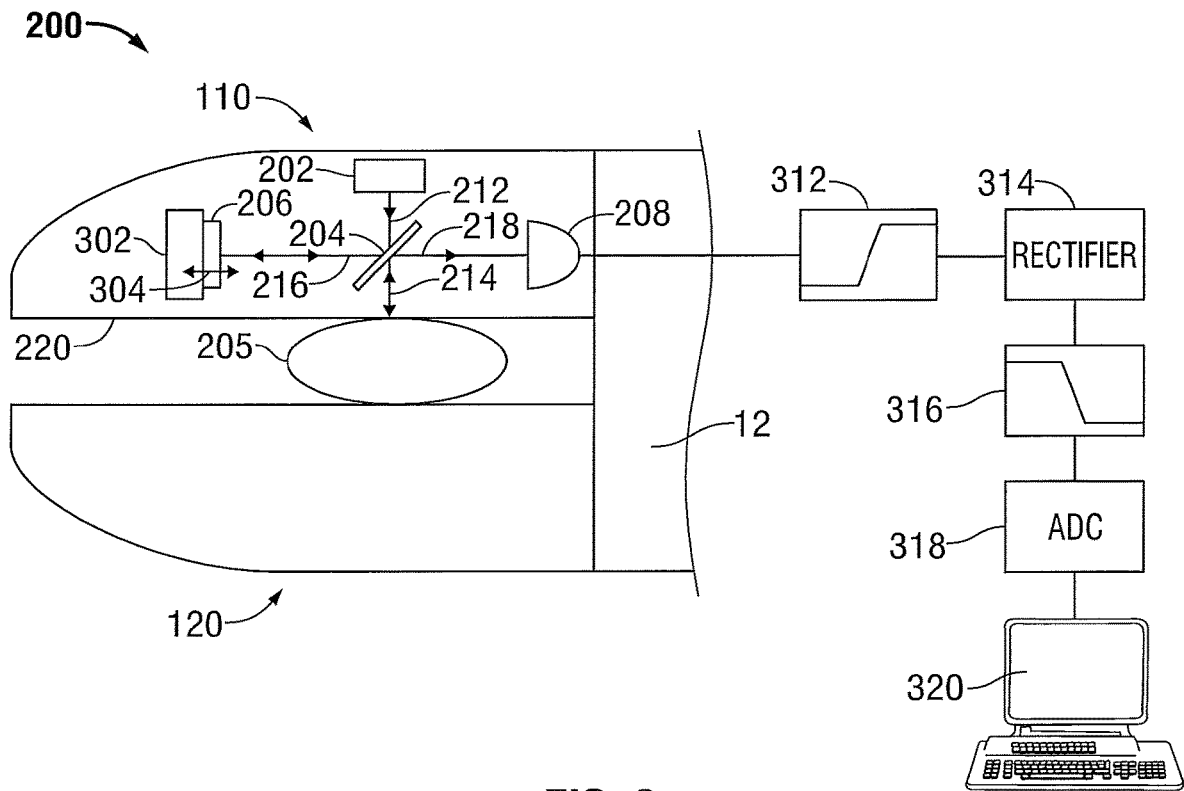

FIG. 3

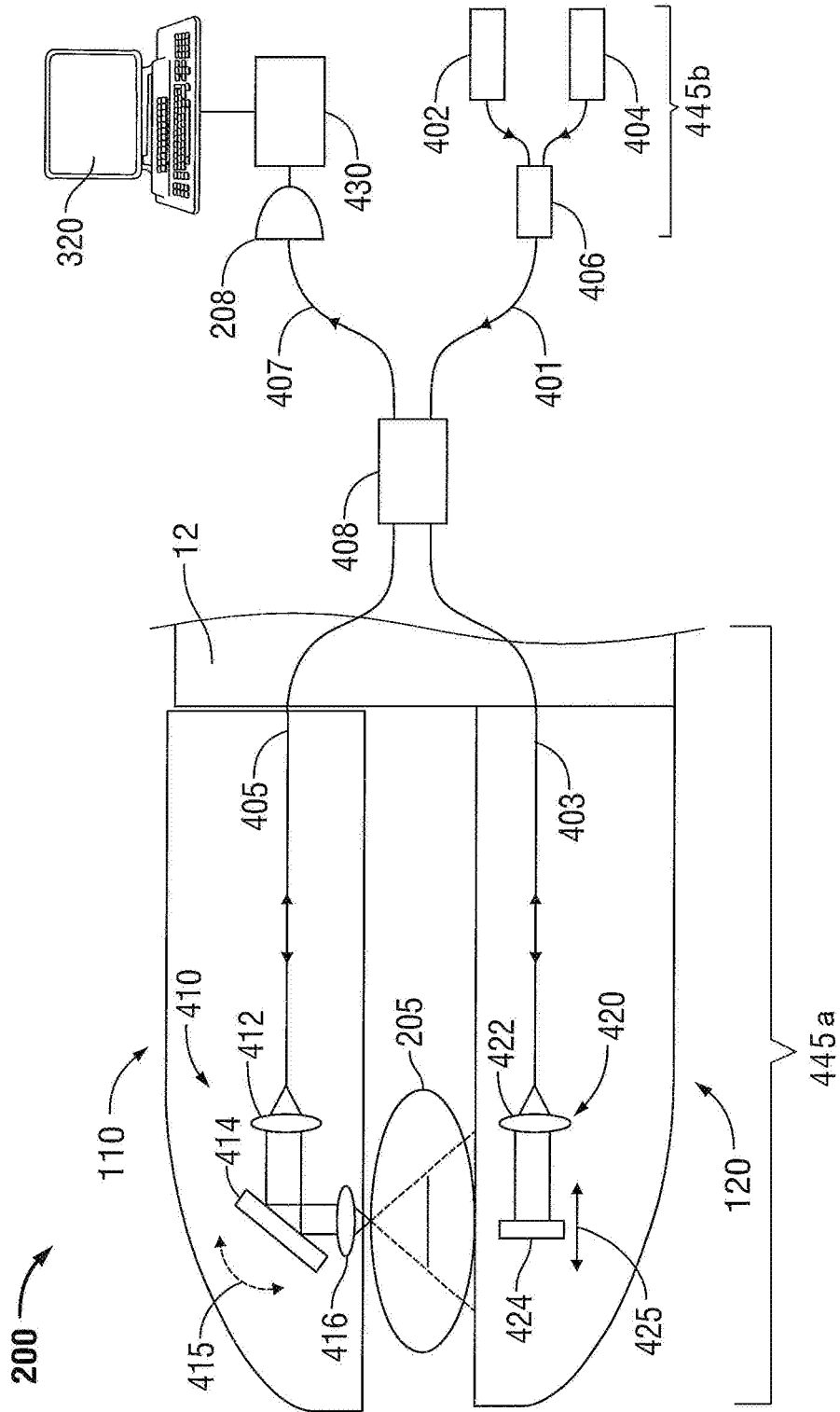

FIG. 4

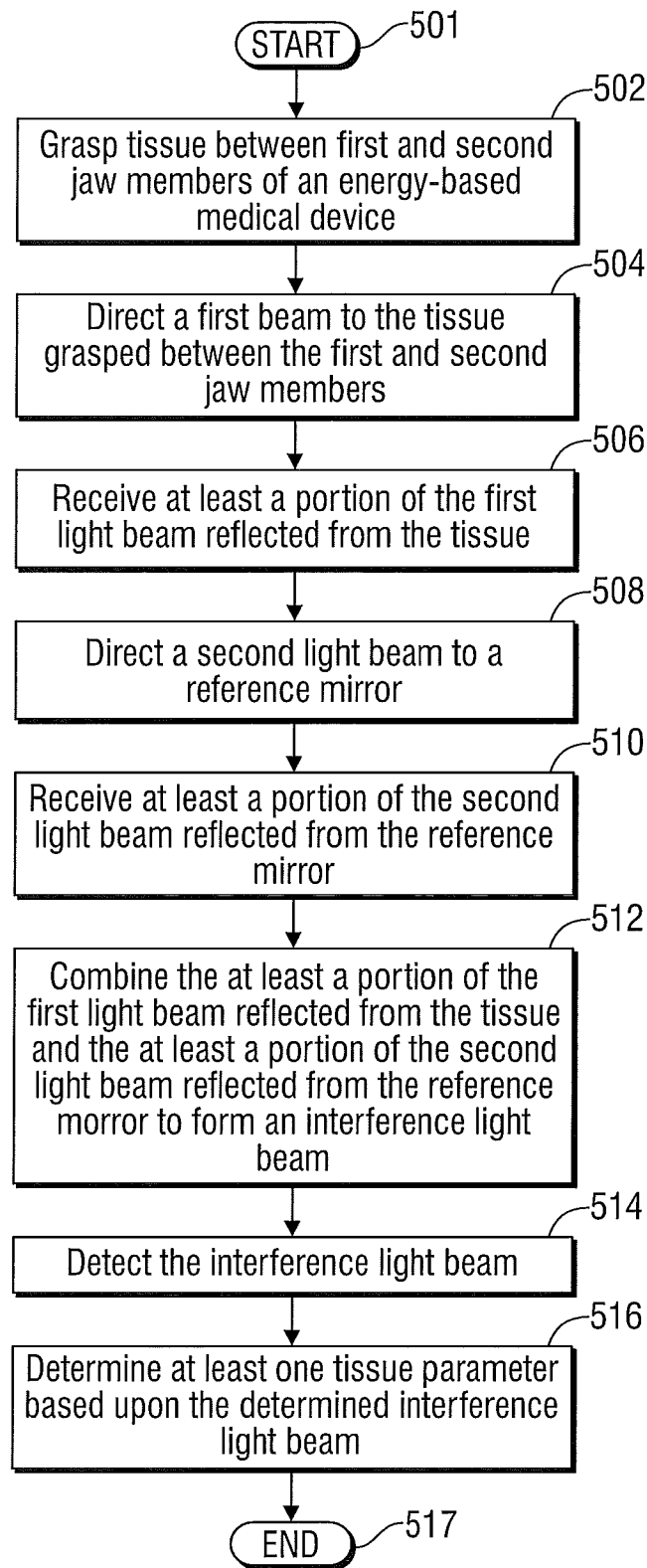

FIG. 5

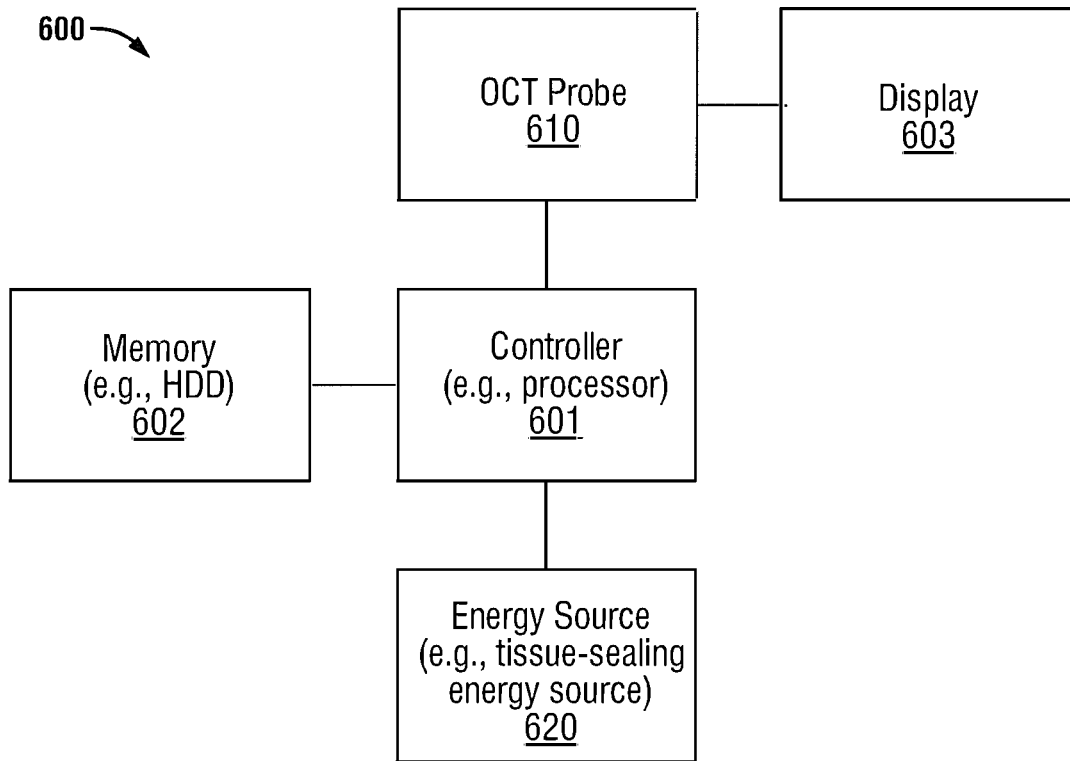

FIG. 6

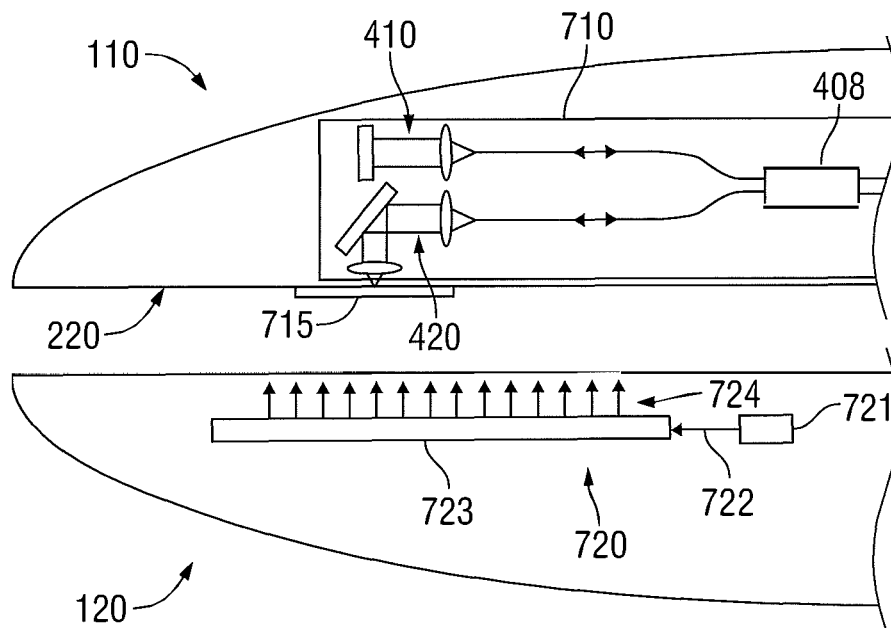

FIG. 7

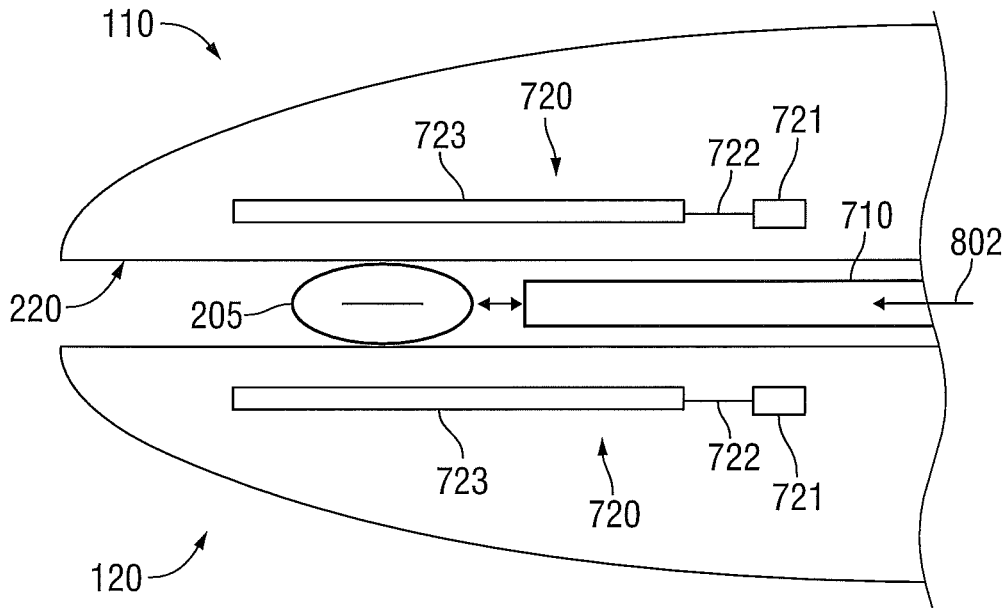

FIG. 8A

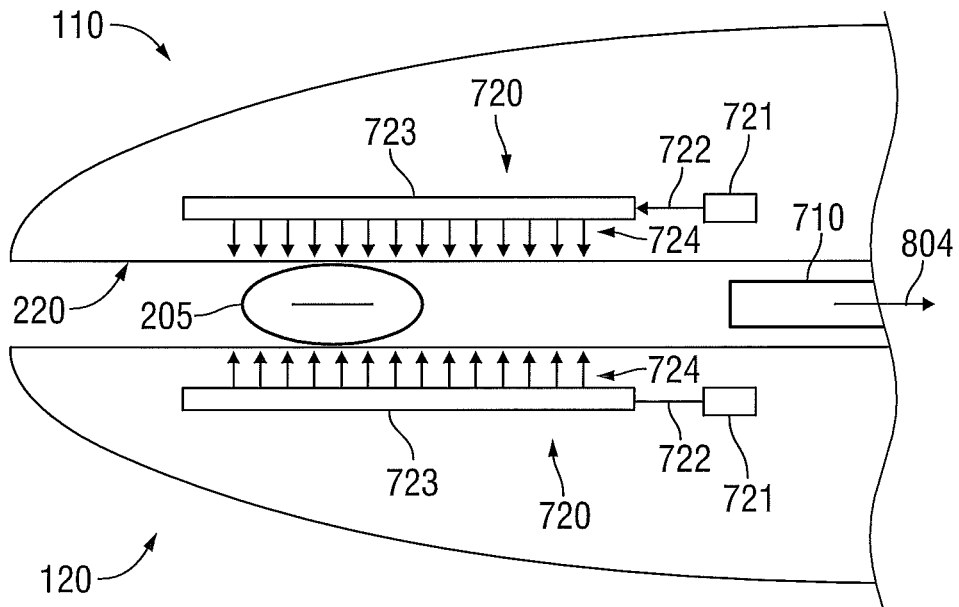

FIG. 8B

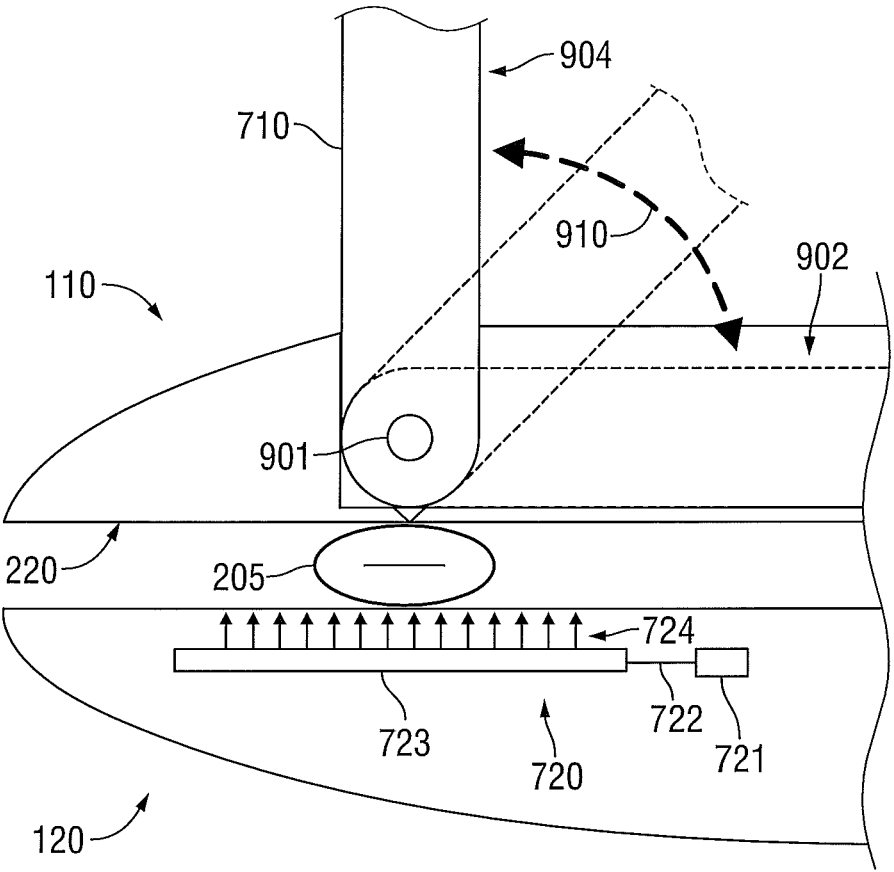

FIG. 9

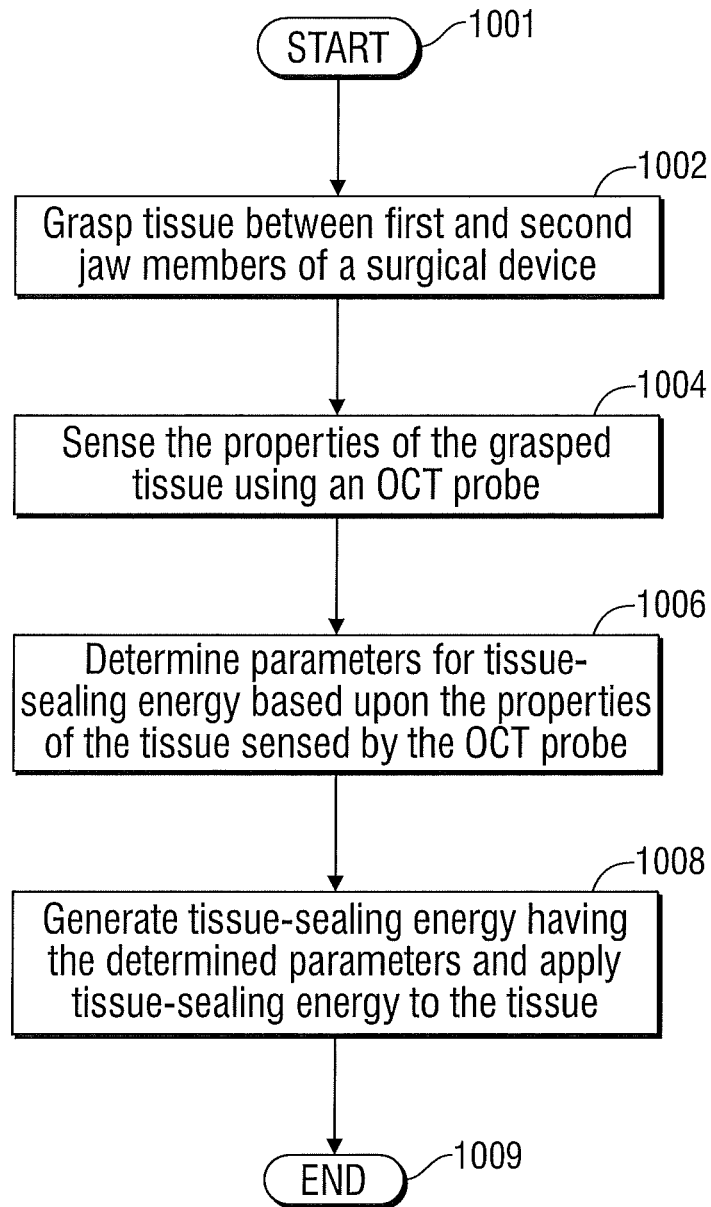

FIG. 10

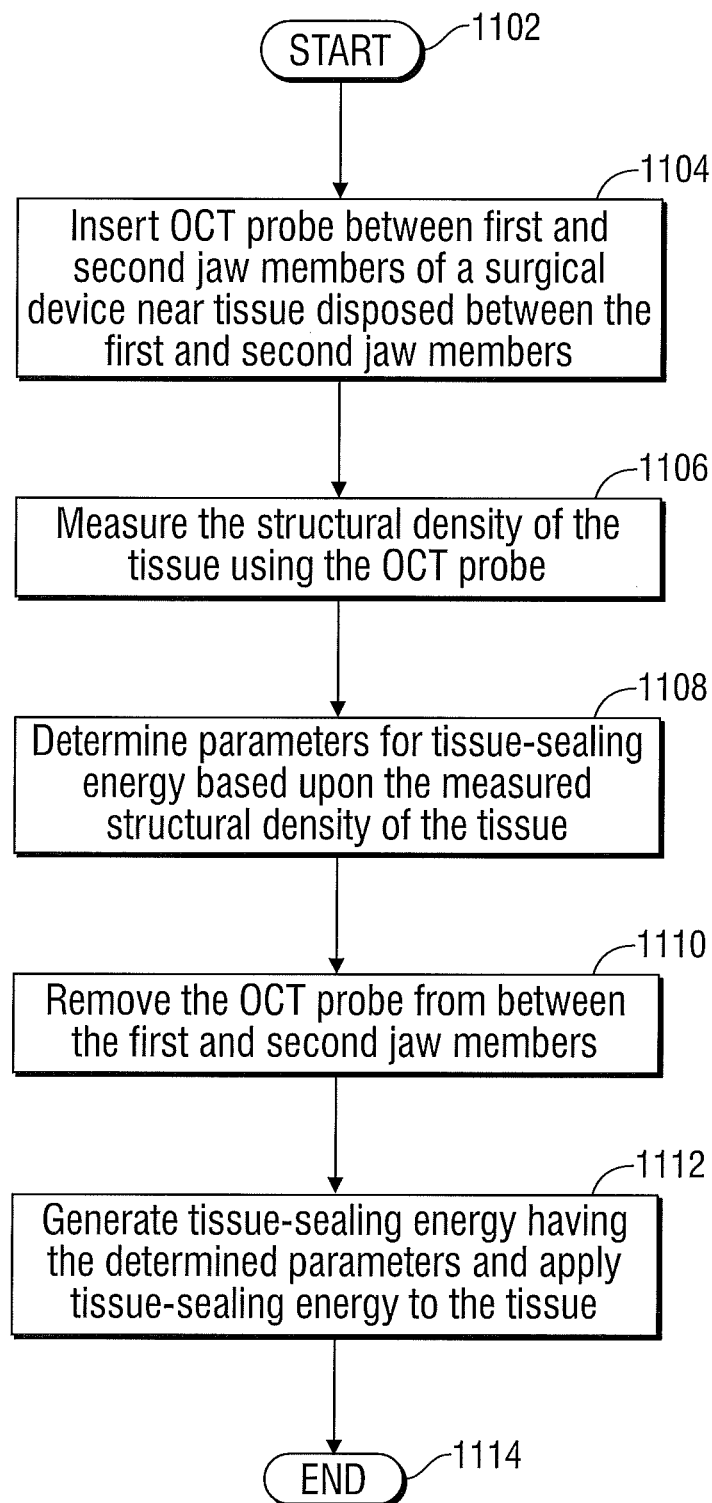

FIG. 11

**SURGICAL DEVICES AND METHODS
UTILIZING OPTICAL COHERENCE
TOMOGRAPHY (OCT) TO MONITOR AND
CONTROL TISSUE SEALING**

CROSS REFERENCE TO RELATED
APPLICATION

The present application is a continuation of U.S. patent application Ser. No. 14/052,827, filed on Oct. 14, 2013, which claims the benefit of and priority to U.S. Provisional Patent Application Ser. No. 61/720,817, filed on Oct. 31, 2012. The entire contents of each of the foregoing applications are hereby incorporated herein by reference.

BACKGROUND

Technical Field

The present disclosure relates to surgical forceps having optical components for monitoring and controlling tissue sealing. More particularly, the present disclosure relates to open or endoscopic forceps that incorporates Optical Coherence Tomography (OCT) system components to monitor and to provide feedback for controlling a tissue sealing.

Description of Related Art

Existing energy-based tissue-sealing surgical forceps use different types of energy to heat tissue. The different types of energy used to heat tissue include direct heat conduction from a heating element, RF current, ultrasound, and light. A typical energy-based tissue-sealing surgical forceps includes jaw members for grasping and compressing the tissue and applying energy to the tissue.

During a surgical procedure, it is important for a surgeon to be able to determine the status of a tissue seal, e.g., the quality of a tissue seal. This feedback allows a surgeon to appropriately operate the tissue-sealing surgical forceps to create a high-quality tissue seal. Existing tissue-sealing surgical forceps and associated systems may not provide sufficient information about the status of a tissue seal.

SUMMARY

As used herein, the term “distal” refers to that portion that is further from an operator while the term “proximal” refers to that portion that is closer to an operator. As used herein, the term “treat” refers to performing a surgical treatment to tissue including, but not limited to heating, sealing, cutting, sensing, and/or monitoring.

As used herein, the term “light source” broadly refers to all types of devices or elements that generate or transmit light for medical use (e.g., tissue treatment). These devices include lasers, light emitting diodes (LEDs), lamps, and other devices that generate light having a wavelength that is within the light spectrum (e.g., from infrared light to ultraviolet light). Also, the light sources described herein may be used interchangeably. For example, an LED light source may be used interchangeably with a laser light source.

As described in more detail below with reference to the accompanying figures, the present disclosure relates to open or endoscopic surgical forceps that incorporates optical and electrical components for performing Optical Coherence Tomography (OCT) to image tissue for diagnostic or identification purposes, or to image a tissue seal after a tissue sealing cycle to determine the quality of the tissue seal. In

some embodiments, the optical components use broadband, infrared light having a wavelength of between 800 and 1550 nm to image subsurface tissue structures at depths of a few millimeters and with a resolution on the order of micrometers.

The optical components may include reference arm optics disposed in a first jaw member of the surgical forceps and sample arm optics disposed in a second jaw member opposite the first jaw member. The optical components also include a light source configured to generate broadband light and transmit the broadband light to the reference arm and the sample arm. The optical components further include a light detector that detects an interference pattern in the broadband light that is reflected back from the reference arm optics and the sample arm optics. The electrical components may include a signal processor that processes the detected interference pattern and displays an image of the sealed tissue on a display device.

The optical components may further include a aiming light source for generating an aiming beam and an optical coupler that optically couples the aiming beam to the broadband light before the resulting light is transmitted to the reference arm optics and the sample arm optics.

The OCT system may incorporate polarization optics to measure birefringence to determine whether collagen has been denatured. In other embodiments, the OCT system may be configured to perform optical coherence microscopy using a high numerical aperture for histology or tissue diagnostics. The numerical aperture (NA) refers to the resolving power of a lens. Values of NA that are greater than 1.2 may be considered high. The optical resolution is proportional to $\lambda/(2 \times \text{NA})$, where λ is the wavelength of the light.

The OCT system may be configured to perform color Doppler coherence tomography to measure tissue perfusion.

In one aspect, the present disclosure features a surgical device. The surgical device includes a housing and an end effector assembly operably coupled to the housing. The end effector assembly includes first and second jaw members that each have a tissue contacting surface. At least one of the first and second jaw members is movable between a first, spaced-apart position and a second proximate position. The end effector assembly further includes a sample arm optical assembly of an interferometer coupled to the first jaw member. The sample arm optical assembly transmits a first light beam to tissue grasped between the first and second jaw members and receives at least a portion of the first light beam reflected from the tissue.

The end effector assembly also includes a reference mirror of the interferometer coupled to the second jaw member. The end effector assembly further includes a reference arm optical assembly of the interferometer coupled to the second jaw member. The reference arm optical assembly transmits a second light beam to the reference mirror and receives at least a portion of the second light beam reflected from the reference mirror.

The sample arm optical assembly may include movable sample arm optics that scan the first light beam across the tissue. The sample arm optical assembly may include a light guide operable to translate and rotate with respect to a longitudinal axis of the first jaw member to scan the tissue.

The reference arm optical assembly may translate along a longitudinal axis of the second jaw member. Alternatively, the reference mirror may translate along a longitudinal axis of the second jaw member.

The first jaw member may be a top jaw member and the second jaw member may be a bottom jaw member.

The surgical device may further include an optical coupler optically coupled to the sample arm optical assembly and the reference arm optical assembly. The optical coupler may provide a first light beam through a first output of the optical coupler to the sample arm optical assembly and may provide

a second light beam through a second output of the optical coupler to the reference arm optical assembly.

The surgical device may include an imaging light source that generates imaging light. The imaging light source may be optically coupled to an input of the optical coupler.

The surgical device may further include a visible light source that generates visible light and a second optical coupler having a first input, a second input, and an output. The first input of the second optical coupler may be optically coupled to the imaging light source and the second input of the second optical coupler may be optically coupled to the visible light source. The second optical coupler may combine the imaging light and the visible light and to transmit the combined light out of the output of the second optical coupler.

A portion of the housing of the surgical device may form a handle and the imaging light source and the visible light source may be disposed within the handle.

The sample arm optical assembly may include polarization optics to allow for birefringence. Alternatively, the sample arm optical assembly and the reference arm optical assembly may be configured for optical coherence microscopy using a high numerical aperture.

In another aspect, the present disclosure features a system for treating tissue. The system includes a surgical device and a processor. The surgical device includes a housing and an end effector assembly operably coupled to the housing. The end effector assembly includes first and second jaw members that each have a tissue contacting surface. At least one of the first and second jaw members is movable between a first, spaced-apart position and a second proximate position. The end effector assembly further includes a sample arm optical assembly of an interferometer coupled to the first jaw member. The sample arm optical assembly transmits a first light beam to tissue grasped between the first and second jaw members and receives at least a portion of the first light beam reflected from the tissue.

The end effector assembly also includes a reference mirror of the interferometer coupled to the second jaw member. The end effector assembly further includes a reference arm optical assembly of the interferometer coupled to the second jaw member. The reference arm optical assembly transmits a second light beam to the reference mirror and receives at least a portion of the second light beam reflected from the reference mirror.

The end effector assembly further includes a light detector that detects at least a portion of the first light beam reflected from the tissue and at least a portion of the second light beam reflected from the reference mirror and generates a light detection signal. The processor of the system for treating tissue is coupled to the light detector and is configured to process the light detection signal to obtain interference pattern data. The processor may be configured to generate an image signal based on the interference pattern data and to transmit the image signal to a display device.

The system may further include an energy source coupled to at least one of the first and second jaw members and a controller coupled to the light detector and the energy source. The energy source delivers energy to the at least one of the first and second jaw members to seal tissue and the controller controls the energy source based on the at least one measured property of the light energy passing through

the tissue. At least one of the energy source and the controller may be disposed within the housing.

In yet another aspect, the present disclosure features a method of determining properties of tissue in an energy-based medical device. The method includes grasping tissue between first and second jaw members of an energy-based medical device by moving at least one of the first and second jaw members between a first, spaced-apart position and a second proximate position. The method further includes directing a first light beam to the tissue grasped between the first and second jaw members, receiving at least a portion of the first light beam reflected from the tissue, directing a second light beam to a reference mirror, receiving at least a portion of the second light beam reflected from the reference mirror, combining the at least a portion of the first light beam reflected from the tissue and the at least a portion of the second light beam reflected from the reference mirror to form an interference light beam, detecting the interference light beam, and determining at least one tissue property based upon the detected interference light beam.

Determining at least one tissue property may include forming an image of the tissue based upon the detected interference light beam. The method may further include controlling the energy applied to the tissue by the energy-based medical device based upon the at least one tissue property. The method may further include determining tissue seal quality, identifying the tissue, or diagnosing the tissue based upon the at least one tissue property.

In one aspect, the present disclosure features a surgical device. The surgical device includes a shaft, an end effector assembly operably coupled to the shaft, and a controller. The end effector assembly includes first and second jaw members, each of which has a tissue-contacting surface. At least one of the first and second jaw members is movable between a first, spaced-apart position and a second proximate position. The end effector assembly further includes a tissue-sealing energy source disposed within at least the first jaw member. The tissue-sealing energy source is configured to provide tissue-sealing energy to tissue disposed between the first and second jaw members.

The end effector assembly further includes an OCT probe configured to sense properties of tissue disposed between the first and second jaw members. The controller is coupled to the OCT probe and the tissue-sealing energy source so that the controller can control the tissue-sealing energy generated by the tissue-sealing energy source based upon the structural density of the vessel sensed by the OCT probe.

The OCT probe may be embedded within the second jaw member. Further, at least a portion of the tissue-contacting surface of the first jaw member may include a transparent optical element that allows light to pass between the OCT probe and the tissue. Still further, the tissue-sealing energy source may generate tissue-sealing light and a reflective element may be disposed on the surface of the transparent optical element to prevent the tissue-sealing light from passing through the transparent optical element.

The OCT probe may be rotatably coupled to the second jaw member so that the OCT probe moves between a position parallel to the longitudinal axis of the second jaw member to a position perpendicular to the longitudinal axis of the second jaw member. Alternatively, the OCT probe may be movably coupled to the shaft so that the OCT probe can move out of the shaft between the first and second jaw members.

The surgical device may further include a second tissue-sealing energy source disposed within the second jaw member. The second tissue-sealing energy source may be con-

figured to provide tissue-sealing energy to tissue disposed between the first and second jaw members.

The tissue-sealing energy source may generate electrical energy or ultrasonic energy.

The controller may be configured to operate the OCT probe to sense a tissue property prior to activating the tissue-sealing energy source. The controller may be additionally or alternatively configured to operate the OCT probe to sense a tissue property while operating the tissue-sealing energy source.

The OCT probe may sense the structural density of the tissue disposed between the first and second jaw members. The controller may correlate the sensed structural density of the tissue to the amount of collagen contained within the tissue disposed between the first and second jaw members.

In another aspect, the present disclosure features a method of sealing tissue. The method includes grasping tissue between first and second jaw members of a surgical device, sensing the structural density of the tissue disposed between the first and second jaw members using an OCT probe, determining parameters for tissue-sealing energy based upon the structural density of the tissue sensed by the OCT probe, and providing the tissue-sealing energy to the tissue based upon the determined parameters of the tissue-sealing energy.

The method of sealing tissue may also include inserting the OCT probe in between the first and second jaw members so that the distal end of the OCT probe is close to the tissue after the tissue is grasped between the first and second jaw members. The method may further include retracting the OCT probe from in between the first and second jaw members after the OCT probe completes sensing the structural density of the tissue grasped between the first and second jaw members.

The method may include sensing the structural density of the tissue disposed between the first and second jaw members using an OCT probe after providing the tissue-sealing energy to the tissue, and determining the quality of the tissue seal based upon the sensed structural density of the tissue.

The method may include rotating the OCT probe from a first position parallel to the longitudinal axis of the second jaw member to a second position perpendicular to the longitudinal axis of the second jaw member prior to activating the OCT probe to sense the structural density of the grasped tissue.

The tissue-sealing energy may be electrical energy or ultrasonic energy. The method may include simultaneously operating the OCT probe to sense the structural density of the tissue and to provide tissue-sealing energy to the tissue. The method of sealing tissue may include correlating the sensed structural density of the grasped tissue to the amount of collagen and/or elastin contained within the grasped tissue.

BRIEF DESCRIPTION OF THE DRAWINGS

Various embodiments of the subject instrument are described herein with reference to the drawings wherein:

FIG. 1A is a perspective view of an endoscopic forceps having an end effector assembly, which incorporates all or a portion of the components of an OCT system, attached to a distal end of the forceps according to some embodiments of the present disclosure;

FIG. 1B is a perspective view of a battery-operated endoscopic forceps having an end effector assembly, which incorporates all or a portion of the components of an OCT system, attached to a distal end of the forceps according to another embodiment of the present disclosure;

FIG. 2 is a schematic side, cross-sectional view of an end effector assembly incorporating optical components of an OCT system according to embodiments of the present disclosure;

FIG. 3 is a schematic diagram of a surgical system incorporating an OCT system according to other embodiments of the present disclosure;

FIG. 4 is a schematic diagram of a surgical system incorporating a fiber-optic OCT system according to yet other embodiments of the present disclosure;

FIG. 5 is a flow diagram of a method of determining properties of tissue in an energy-based medical device according to embodiments of the present disclosure.

FIG. 6 is a schematic diagram of a surgical system according to embodiments of the present disclosure;

FIG. 7 is a schematic diagram of a surgical system incorporating a fiber-optic OCT system and a light energy delivery system according to embodiments of the present disclosure;

FIGS. 8A and 8B are schematic diagrams of surgical systems incorporating a fiber-optic OCT system and a light energy delivery system according to other embodiments of the present disclosure;

FIG. 9 is a schematic diagram of a surgical system incorporating a fiber-optic OCT system and a light energy delivery system according to yet other embodiments of the present disclosure;

FIG. 10 is a flow diagram of a method of sealing tissue with an energy-based medical device according to embodiments of the present disclosure; and

FIG. 11 is a flow diagram of a method of sealing tissue with an energy-based medical device according to other embodiments of the present disclosure.

DETAILED DESCRIPTION

Embodiments of the presently-disclosed surgical instrument are described in detail with reference to the drawings wherein like reference numerals identify similar or identical elements.

FIG. 1A shows an endoscopic surgical forceps **10** that incorporates the OCT systems described below. In FIG. 1A, forceps **10** is coupled to an energy source (e.g., a generator **40**) for generating energy, such as electrical energy, ultrasonic energy, or light energy configured to seal tissue. The energy source (e.g., generator **40**) is configured to output energy having desired characteristics. Forceps **10** is coupled to the generator **40** via a cable **34** that is configured to transmit energy and control signals between the forceps **10** and the generator **40**. Various embodiments of the forceps **10** using various types of energy are described below.

Forceps **10** is configured to support an end effector assembly **100**. Forceps **10** includes various conventional features (e.g., a housing **20**, a handle assembly **22**, a trigger assembly **25**, and a rotating assembly **28**) that enable forceps **10** and end effector assembly **100** to mutually cooperate to grasp, seal, divide, and/or sense tissue. Forceps **10** generally includes a housing **20** and a handle assembly **22** that includes a moveable handle **24** and a handle **26** that is integral with housing **20**. The handle **24** is moveable relative to the handle **26** to actuate end effector assembly **100** via a drive assembly (not shown) to grasp tissue.

In some embodiments, trigger assembly **25** may be configured to actuate a knife blade (not shown) or another component to sever tissue after a successful seal. Forceps **10** also includes a shaft **12** having a distal portion **16** that mechanically engages end effector assembly **100** and a

proximal portion **14** that mechanically engages housing **20** proximate rotating assembly **28** disposed on housing **20**. Rotating assembly **28** is mechanically associated with shaft **12** such that rotational movement of rotating assembly **28** imparts similar rotational movement to shaft **12** that, in turn, rotates end effector assembly **100**.

End effector assembly **100** includes two jaw members **110**, **120** having proximal ends and distal ends (see FIG. 1A). One or both jaw members **110**, **120** are pivotable about a pin **19** and one or both jaw members **110**, **120** are movable from a first position wherein jaw members **110**, **120** are spaced relative to another, to a second position wherein jaw members **110**, **120** are closed and cooperate to grasp tissue between the jaw members **110**, **120**.

Each jaw member **110**, **120** includes a tissue contacting surface disposed on an inner-facing surface thereof (see FIG. 1A). Tissue-contacting surfaces cooperate to grasp and seal tissue held between the tissue-contacting surfaces. Tissue-contacting surfaces are connected to generator **40** that can transmit energy through the tissue held between the tissue-contacting surfaces.

First and second switch assemblies **30** and **32** are configured to selectively provide energy to end effector assembly **100**. More particularly, the first switch assembly **30** may be configured to perform a first type of surgical procedure (e.g., seal, cut, and/or sense) and a second switch assembly **32** may be configured to perform a second type of surgical procedure (e.g., seal, cut, and/or sense). It should be noted that the presently-disclosed embodiments may include any number of suitable switch assemblies and are not limited to only switch assemblies **30** and **32**. It should further be noted that the presently-disclosed embodiments may be configured to perform any suitable surgical procedure and are not limited to only sealing, cutting, and sensing.

The handle assembly **20** may further include one or more light transmissive elements, such as a cable or optical fibers **34** that connects the forceps **10** to the generator **40**. The cable **34** may include a plurality of optical fibers to transmit light through various paths and ultimately to the OCT system incorporated into the end effector assembly **100**, which is described in further detail below.

First and second switch assemblies **30** and **32** may also cooperate with a controller **42**, which may be implemented by a logic circuit, a computer, a processor, and/or a field programmable gate array. The controller **42** may automatically trigger one of the switches to change between a first mode (e.g., sealing mode) and a second mode (e.g., cutting mode) upon the detection of one or more parameters or thresholds. In some embodiments, the controller **42** is also configured to receive various sensor feedback and to control the generator **40** based on the sensor feedback. The embodiments of the present disclosure allow the jaw members **110**, **120** to seal and/or cut tissue using any suitable form of energy.

In some embodiments, the controller **42** may include a feedback loop that indicates when a tissue seal is complete based upon one or more of the following parameters: tissue temperature, optical sensing, change in impedance of the tissue over time and/or changes in the optical or electrical power or current applied to the tissue over time, rate of change of these properties and combinations thereof. An audible or visual feedback monitor may be employed to convey information to the surgeon regarding the overall seal quality or the completion of an effective tissue seal.

Referring now to FIG. 1B, forceps **11** is shown having a portable configuration and includes an internal generator **50** for generating energy that is operably coupled to a battery

compartment **52** via one or more wires **50a**. In some embodiments, one or more battery operated laser diodes or fiber lasers may also be used to provide a portable light energy source. The internal generator **50** may be configured to provide energy to the end effector assembly **100**. The battery compartment **52** may be configured to receive one or more batteries **54** for providing suitable energy to internal generator **50**. In embodiments, the controller **42** may also be disposed within the forceps **11** (e.g., the housing **20**).

Battery compartment **52** may be defined within any suitable portion of housing **20** of forceps **11**, such as the fixed handle **26**, as shown in FIG. 1B. Suitable batteries may include, but are not limited to a nickel-cadmium, lithium-ion, rechargeable, or any other suitable type. The location of internal generator **50** provides an operator increased maneuverability and convenience when performing a surgical treatment with forceps **11**.

FIG. 2 illustrates an end effector assembly **100** according to some embodiments of the present disclosure, which is configured for use with either surgical instrument **10** or surgical instrument **11** described above or any other suitable surgical instruments. However, for purposes of simplicity and consistency, end effector assembly **100** is described below with reference to instrument **10**.

The end effector assembly **100** includes a first jaw member **110** that incorporates a free-space OCT system **200**. The OCT system **200** includes a light source **202**, a beamsplitter **204**, a reference mirror **206**, and a light detector **208**. The light source **202** is electrically coupled to the generator **40** to receive power and/or command signals from the generator **40**. The light detector **208** is electrically coupled the generator **40** to provide light detection signals to the generator **40** and to receive power from the generator **40**.

In operation, the light source **202** (e.g., a monochromatic light source) emits a source beam **212** toward the beamsplitter **204**, which is positioned diagonally with respect to the source beam **212**. The beamsplitter **204** splits the source beam **212** into two halves: a first beam **214** and a second beam **216**. The first beam **214** is transmitted through the beamsplitter **204** and then is reflected back from the tissue **205** towards the beamsplitter **204**. The second beam **216** is reflected off the beamsplitter **204** and then is reflected back towards the beamsplitter **204** by the reference mirror **206**. The back-reflected first beam **214** and the back-reflected second beam **216** are recombined by the beamsplitter **204** into a recombined beam **218** that is detected by the light detector **208**. The light detector **208** then transmits an electrical signal representing the detected recombined beam **218** to the generator **40**, which detects an interference pattern based on the electrical signal and displays an image of the tissue **205** based on the detected interference pattern.

FIG. 3 is a schematic diagram of a surgical system **300** incorporating an OCT system having an optical assembly **305** and an electrical assembly **310**. As shown, the surgical system **300** includes an end effector assembly **301** that incorporates the optical assembly **305** and the electrical assembly **310**. The configuration of the optical assembly **305** is similar to the configuration of the optics in FIG. 2, except that the reference mirror **206** is disposed on a movable element **302** that can move the reference mirror **206** along a horizontal axis **304** to perform scanning of the tissue.

FIG. 3 also illustrates the electrical assembly **310** of the OCT system that receives the interference signal generated by the light detector **208**. The electrical assembly **310** may be disposed in the generator of FIG. 1. The electrical assembly **310** includes an amplifier **312**, a demodulator **314**, and an analog-to-digital converter (ADC) **316**. The amplifier

312 amplifies the light detector signals and the demodulator 314 demodulates the amplified signals as the reference mirror 206 is moved along a horizontal axis 304. The demodulator 314 provides scan signals to the ADC 316, which converts the scan signals into digital scan data. The digital scan data are then provided to a computer system 320 that generates an image that is displayed on the display of the computer system 320. In addition or in the alternative, the computer system 320 may analyze the digital scan data to identify the tissue, to determine the status of the tissue being sealed, or to determine that quality of a tissue seal.

In some embodiments, the computer system 320 may be incorporated into the forceps 11 of FIG. 1B. For example, the processor of the computer system 320 may be incorporated into the internal generator 50 of the forceps 11 and a display of the computer system 320 may be disposed on the housing 20 of the forceps 11.

FIG. 4 is a schematic diagram of a surgical system 400 incorporating a fiber-optic OCT system. A first portion 445a of the fiber-optic OCT system is incorporated into the jaw members 110, 120 of the end-effector assembly 440. The first portion 445a of the fiber-optic OCT system includes a sample arm 410, which is incorporated into the first jaw member 110, and a reference arm 420, which is incorporated into the second jaw member 120. Alternatively, the reference arm 420 may be incorporated into the generator 40 of FIG. 1A.

A second portion 445b of the fiber-optic OCT system is disposed outside of the end-effector assembly 440. In some embodiments, the second portion 445b of the fiber-optic OCT system is disposed in the generator 40 of FIG. 1A. In other embodiments, the second portion 445b of the fiber-optic OCT system is disposed in the internal generator 50 of FIG. 1B.

As shown in FIG. 4, the second portion 445b of the fiber-optic OCT system includes two light sources: an imaging light source 402 and a visible light source 404. The imaging light source 402 may be a broadband source (e.g., a broadband, near-infrared source) that generates an imaging beam to image tissue. Examples of broadband sources include super-luminescent diodes, fiber amplifiers, and femto-second pulse lasers that generate light having a wavelength that ranges between 800 and 1550 nanometers. The visible light source 404 generates a visible aiming beam. The outputs of the imaging light source 402 and the visible light source 404 are optically coupled to a 2x1 optical coupler 406, which combines the imaging light beam with the visible light beam so that a user can see the imaging light beam.

The light output from the 2x1 optical-fiber coupler 406 is coupled into optical fiber 401 of the fiber-optic interferometer. The light is split into two optical fibers—a reference arm optical fiber 403 and a sample arm optical fiber 405—using a 2x2 optical-fiber coupler 408. The reference arm optical fiber 403 is optically coupled to reference arm optics 420. The reference arm optics 420 includes a lens 422, such as a convex lens, and a reference mirror 424. The lens 422 forms a light beam from the light emitted from the reference arm optical fiber 403 and directs it to the reference mirror 424. The light reflects off the reference mirror 424 and travels back towards the optical-fiber coupler 408 through the lens 422 and the reference arm optical fiber 403.

A sample arm optical fiber 405 is coupled to the sample arm optics 410, which transmits light to the tissue 205. The light is reflected from the tissue 205 back into the sample arm optical fiber 405. The light is reflected from the tissue as a result of changes in the index of refraction within the

structure of the tissue, e.g., between intercellular fluid and collagen fibers. The light reflected back from the tissue 205 and the light reflected back from the reference mirror 424 are recombined within the 2x2 fiber-optical coupler 408.

Because of the short coherence length of the broadband light source 402, the light reflected from the tissue and the light reflected from the reference mirror 424 will interfere constructively and destructively only if the optical path lengths of the sample arm 410 and the reference arm 420 are matched. By changing the length of the reference arm, the tissue can be sampled at various depths.

The light recombined by the 2x2 fiber-optical coupler 408 is provided to the optical detector 208, e.g., a photodiode via optical fiber 407. The optical detector 208 detects the interference between the light reflected from the tissue and the light reflected from the reference mirror 424. During OCT imaging, the reference mirror 424 is scanned along the longitudinal axis 425 A-A of the second jaw member 120 at a constant velocity, thus allowing depth scans of the tissue (analogous to ultrasound A-scans).

The sample arm optics 410 may be configured to perform lateral scans across the tissue to construct two- and three-dimensional images. In the embodiment shown in FIG. 4, the sample arm mirror 414 may be rotatable 415 about a transverse axis B-B of the first jaw member 110 to scan the tissue 205 along the longitudinal axis of the first jaw member 110. The detected interference signals from this scan are then used to construct a two-dimensional cross-sectional image of the tissue 205.

The optical detector 208 then transmits the detected interference signal to a processor 430, which forms an image of the tissue based on the detected interference signal. The image is then displayed on a computer display 320.

The surgical systems according to embodiments of the present disclosure may generate images of a region of tissue so that a surgeon can determine the status of the tissue after a sealing procedure. For example, the surgeon can use the generated images to verify whether or not the tissue has been sealed or to determine whether or not the tissue has been properly sealed.

FIG. 5 is a flow diagram of a method for determining properties of tissue in an energy-based medical device according to embodiments of the present disclosure. After starting in step 501, tissue is grasped between first and second jaw members of an energy-based medical device in step 502. In step 504, a first light beam is directed to the tissue grasped between the first and second jaw members and, in step 506, at least a portion of the first light beam reflected from the tissue is received, e.g., by a light detector. In step 508, a second light beam is directed to a reference mirror, and, in step 510, at least a portion of the second light beam reflected from the reference mirror is received, e.g., by the light detector.

In step 512, at least a portion of the first light beam reflected from the tissue and at least a portion of the second light beam reflected from the reference mirror are combined to form an interference light beam. Finally, before ending in step 517, the interference light beam is detected in step 514 and one or more tissue properties are determined based upon the detected interference light beam in step 516. The tissue properties may include tissue type, cell type, disease state, or disease pathology.

As described herein, the energy-based medical devices may have an OCT probe embedded within the jaw members or the OCT probe may be a retractable probe that is deployed from the shaft of the medical device. In these configurations, the OCT imaging may be performed prior to energy delivery

when the jaw members clamp onto unsealed tissue, to determine the structural density of the tissue. The structural density information would then be relayed to a controller to adjust the temperature and/or energy to perform a tissue seal. The OCT imaging may also be performed after performing a tissue sealing procedure so that the clinician can determine the success and/or quality of the tissue seal. This type of imaging/sealing medical device would be beneficial when sealing large vessels and thick tissue masses.

The OCT imaging may be used in combination with any type of energy-based medical device including medical devices that treat tissue using light energy, radio frequency energy, or ultrasound energy.

FIG. 6 is a schematic diagram of surgical system 600 that incorporates an OCT probe. The surgical system 600 includes a controller 601, a memory 602, a display 603, an OCT system 610, and a generator or energy source 620. The controller 601 is electrically connected to the energy source 620 to control the energy output from the energy source 620. The energy source 620 may output light energy, electrical energy, or ultrasonic energy. The controller 601 controls the amount of energy output from the energy source 620 to achieve a desired tissue effect. For example, in the case that the energy source 620 is a light energy source, the controller 601 controls the intensity and/or other properties of the light energy, e.g., polarization, to seal tissue that is placed between the jaws of a surgical device.

According to the present disclosure, the controller 601 is electrically connected to the OCT system 610 to receive optical feedback information, which is used by the controller 601 to adjust the properties of the energy output from the energy source 620. The optical feedback information includes images that indicate the structural density and/or other properties of the tissue that is placed between the jaws of a surgical instrument. As described herein, all or a portion of the surgical system 600 may be incorporated into a surgical instrument. For a portable surgical instrument, all of the components of the surgical system 600 may be incorporated into the surgical instrument.

The controller 601, which may be a processor, a digital signal processor, a central processing unit (CPU), or micro-processor, is coupled to the memory 602, which may be a non-volatile memory such as ROM or NVRAM. The controller 601 may retrieve instructions from the memory 602 and may execute the instructions to control the energy source 620 based on feedback from the OCT system 610.

The OCT system 610 may be coupled to a display 603 that displays images of the tissue obtained by the OCT system 610. The display 603 may allow for an operating mode in which a user may manually adjust the amount of energy output from the energy source 610 as the user views the display 603.

According to the present disclosure, the OCT probe may be embedded in a jaw member of a tissue-sealing surgical device, e.g., an optical vessel sealer, which allows for imaging of tissue to be performed before and after the tissue seal without device reconfiguration. The jaw member may include a transparent window disposed at or near the tissue-contacting surface of the jaw member to allow for imaging of tissue disposed between the jaw members of the tissue-sealing surgical device.

FIG. 7 is a schematic diagram of a surgical system incorporating a fiber-optic OCT probe 710 and a light-energy delivery system 720. The fiber-optic OCT probe 710 is incorporated into the first jaw member 110 and the light-energy delivery system 820 is incorporated into the second jaw member 120. The fiber-optic OCT probe 710

incorporates similar components as the fiber-optic OCT system shown in FIG. 4. The fiber-optic OCT probe 710 includes a sample arm 410 and a reference arm 420 and an optical coupler 408. The OCT probe 710 may be optically coupled to the remaining components of an OCT system, which are illustrated above in FIG. 4.

The light-energy delivery system 720 includes a light source 721, an optical fiber or other light waveguide 722, and a light distribution element 723. The light source 721 generates light having an appropriate intensity and wavelength for sealing or otherwise treating tissue disposed between the jaw members 110 and 120. The optical fiber 722 carries the light generated by the light source 721 to the light distribution element 723, which forms and distributes a light beam perpendicular to or substantially perpendicular to the tissue-contacting surface of the second jaw member 120.

A method of using the surgical system of FIG. 7 may include grasping tissue between the first and second jaw members 110 and 120, sensing optical properties of the tissue using the OCT probe 710, and delivering light to tissue using the light-energy delivery system 720 based on the sensed optical properties of the tissue.

Vessels containing large and small amounts of collagen show differences in structural density. Specifically, vessels with large collagen content have greater structural density than vessels with low collagen content. Thus, OCT may be used to detect the structural density of vessels, which may then be correlated to collagen content.

Preliminary testing has shown that vessels with a large amount of collagen content (e.g., the carotid artery) are more consistently sealed than vessels with low collagen content (e.g., the femoral artery). Since collagen has a lower denaturation temperature than elastin, tissues with higher collagen content may form seals at lower temperatures. Thus, OCT may be used to determine the collagen or elastin content of tissue, and the amount of energy delivered to the tissue may be controlled based on the collagen or elastin contents of the tissue.

For example, OCT may be used to determine the amount of collagen and/or elastin in a vessel disposed between the jaw members 110 and 120. If the OCT probe 710 senses a large amount of collagen in the vessel, then the light-energy delivery system 720 may deliver less energy to the vessel as compared to another vessel having a smaller amount of collagen because collagen has a lower denaturation temperature.

The tissue-contacting surface 220 of the first jaw member 110 may be coated with a reflective layer 715 adjacent the light output of the sample arm 410 of the fiber-optic OCT probe 710 so that the light beam from the light-energy delivery system 720 does not damage the components of the fiber-optic OCT probe 710.

In another mode of operation, the OCT probe 710 and the light-energy delivery system 720 may be operated simultaneously. In other words, the OCT probe 710 may sense optical properties of the tissue while the light-energy delivery system 720 is delivering light to the tissue. In this mode of operation, a controller (not shown) coupled to the light-energy delivery system 720 may control the intensity of the light produced by the light-energy delivery system 720.

FIGS. 8A and 8B are schematic diagrams of a surgical system incorporating light-energy delivery systems 720 into both the first and second jaw members 110 and 120. Specifically, each of the first and second jaw members 110 and 120 includes a light source 721, an optical fiber or waveguide 722, and a light distribution element 723. The OCT probe 710 is movably coupled to the surgical device so that

it can be inserted into and removed from between the first and second jaw members **110** and **120**.

In an example mode of operation, tissue is grasped between the first and second jaw members **110** and **120** of a surgical device. Next, the OCT probe **710** is inserted **802** between the first and second jaw members **110** and **120** so that the distal end of the OCT probe **710** is disposed adjacent to the tissue. Then, the OCT probe is operated to sense the properties of the tissue disposed between the first and second jaw members. A controller (not shown) coupled to the OCT probe **710** may determine parameters for light energy based upon the properties of the tissue sensed by the OCT probe **710**.

Next, as illustrated in FIG. **8B**, the OCT probe **710** is removed **804** from in between the first and second jaw members **110** and **120**. Then, the controller (not shown) may operate the light-energy delivery systems **720** according to the determined parameters for the light energy. The controller may operate the light-energy delivery systems **720** so that they simultaneously and/or alternatively deliver light to the tissue.

In other embodiments, the light energy delivery systems **723** may be replaced by other energy delivery systems such as ultrasonic or electrical energy delivery systems. These alternative energy delivery systems may be operated in the same manner as described above with respect to the light energy delivery systems **720**.

FIG. **9** is a schematic diagram of a surgical system incorporating the light energy delivery system **720** and a rotatable OCT probe **710**. As shown in FIG. **9**, the OCT probe **710** is rotatable **910** about the pin **901** from a first position **902** to a second position **904**. The first position **902** may be a position at which the OCT probe **710** is not used and the second position **904** may be a position at which the OCT probe **710** is operated to sense properties of the tissue disposed between the jaw members **110** and **120**.

Thus, according to one method of operation, the first and second jaw members **110** and **120** are operated to grasp tissue **205** and the OCT probe **710** is rotated from the first position **902** to the second position **904**. Then, the OCT probe **710** is operated to sense properties of the tissue **205**. After the OCT probe **710** senses the properties of the tissue **205**, the OCT probe **710** may be rotated back to the first position **902** before the light-energy delivery system **720** delivers light to the tissue **205**. Alternatively, the OCT probe **710** may remain in the second position **904** while the light-energy delivery system **720** delivers light to the tissue **205**. Then, the light-energy delivery system **720** delivers light to the tissue **205**.

FIG. **10** is a flow diagram of a method of sealing tissue using an energy-based surgical device. After starting in step **1001**, tissue is grasped between the first and second jaw members of the surgical device in step **1002**. In step **1004**, the properties of the tissue disposed between the first and second jaw members are sensed using an OCT probe. The sensed properties of the tissue may include the structural density or structural profile of the tissue.

In step **1006**, parameters of tissue-sealing energy are determined based upon the properties of the tissue sensed by the OCT probe. These parameters may include power, voltage, and/or current in the case of electro-surgical and ultrasonic surgical devices. In the case of light-based surgical devices, the parameters may include intensity, frequency, wavelength, and/or polarization. The parameters may also include temperature.

For example, if the OCT probe senses a high structural density of vascular tissue disposed between the first and

second jaw members, which indicates a large concentration of collagen within the vascular tissue, the intensity and wavelength of a light beam generated by a light-based surgical instrument may be controlled so that a sufficient amount of light energy is provided to the vascular tissue to denature the collagen within the vascular tissue.

Before the method ends in step **1009**, tissue-sealing energy having the determined parameters is generated and applied to the tissue.

FIG. **11** is a flow diagram of another method of sealing tissue using an energy-based surgical device. After starting, in step **1102**, an OCT probe is inserted between first and second jaw members of a surgical device near tissue disposed between the first and second jaw members, in step **1104**. In step **1106**, the structural density of the tissue disposed between the first and second jaw members are measured using the OCT probe. In step **1108**, parameters for tissue-sealing energy to be applied to the tissue are determined based upon the structural density of the tissue measured in step **1106**.

After determining the parameters for the tissue-sealing energy to be applied to the tissue in step **1108**, the OCT probe is removed from between the first and second jaw member in step **1110** so that the probe is not exposed to the tissue-sealing energy. Then, before the method ends in step **1114**, tissue-sealing energy having the determined parameters is generated and applied to the tissue.

The OCT systems described above may be modified to monitor different properties of tissue. For example, the sample arm optics **410** and the reference arm optics **420** of the OCT system could incorporate polarization-altering optics (e.g., polarized lenses, plates, or windows) to determine the tissue birefringence based upon the magnitude of the back-reflected light.

The OCT systems may be configured to perform optical coherence microscopy for histology or tissue diagnostics. The OCT system may incorporate optical elements to achieve resolutions comparable to confocal microscopy but with increased depth of penetration. For example, the OCT system may incorporate optical elements having a high numerical aperture (e.g., the lens **416** may have a high numerical aperture) to achieve high resolutions and a large penetration depth.

The surgical systems of the present disclosure (e.g., the surgical system **400** of FIG. **4**) may incorporate mechanisms for selectively applying different optical elements to achieve different optical effects. In some embodiments, the surgical system **400** may include a mechanism that switches between a standard optical element (e.g., the lens **416**) and an optical element having a high numerical aperture. In other embodiments, a polarization-altering optical element may be inserted in series with the standard optical element (e.g., the lens **416**).

In other embodiments, the OCT systems may be configured to perform color Doppler optical coherence tomography (CDOCT) to measure tissue perfusion, i.e., the amount of blood that flows through tissue.

While several embodiments of the disclosure have been shown in the drawings and/or discussed herein, it is not intended that the disclosure be limited thereto, as it is intended that the disclosure be as broad in scope as the art will allow and that the specification be read likewise. Therefore, the above description should not be construed as limiting, but merely as exemplifications of particular embodiments. Those skilled in the art will envision other modifications within the scope and spirit of the claims appended hereto.

What is claimed is:

1. A surgical system comprising:
 - a housing;
 - an end effector assembly operably coupled to the housing, the end effector assembly including:
 - 5 first and second jaw members each having a tissue contacting surface, at least one of the first or second jaw members movable between a first, spaced-apart position and a second grasping position;
 - a sample arm optical assembly of an interferometer within the first jaw member, the sample arm optical assembly configured to transmit a first light beam to tissue grasped between the first and second jaw members and to receive at least a portion of the first light beam reflected from the tissue;
 - 15 a reference mirror of the interferometer within the first jaw member;
 - a reference arm optical assembly of the interferometer within the first jaw member, the reference arm optical assembly configured to transmit a second light beam to the reference mirror and to receive at least a portion of the second light beam reflected from the reference mirror; and
 - 20 an optical coupler within the first jaw member and optically coupled to the sample arm optical assembly and the reference arm optical assembly, the optical coupler configured to:
 - provide the first light beam through a first output of the optical coupler to the sample arm optical assembly,
 - 30 provide the second light beam through a second output of the optical coupler to the reference arm optical assembly, and
 - provide a third light beam through a third output of the optical coupler, the third light beam based on the portion of the first light beam reflected from the tissue and the portion of the second light beam reflected from the reference mirror; and
 - a processor configured to process a signal based on the third light beam and obtain interference pattern data.
2. The surgical system according to claim 1, wherein the sample arm optical assembly includes movable sample arm optics configured to scan the first light beam across the tissue.
3. The surgical system according to claim 1, wherein the sample arm optical assembly includes a light guide operable to translate along and rotate with respect to a longitudinal axis of the first jaw member to scan the tissue.
4. The surgical system according to claim 1, wherein the reference arm optical assembly is operable to translate along a longitudinal axis of the first jaw member.
5. The surgical system according to claim 1, wherein the reference mirror is operable to translate along a longitudinal axis of the first jaw member.
6. The surgical system according to claim 1, wherein the first jaw member is a top jaw member and the second jaw member is a bottom jaw member.
7. The surgical system according to claim 1, further comprising an imaging light source that generates imaging light, the imaging light source optically coupled to an input of the optical coupler.
8. The surgical system according to claim 7, further comprising:
 - a visible light source that generates visible light; and
 - 65 a second optical coupler comprising a first input, a second input, and an output, the first input of the second optical coupler optically coupled to the imaging light source

- and the second input of the second optical coupler optically coupled to the visible light source, the second optical coupler configured to combine the imaging light and the visible light and to transmit the combined light out of the output of the second optical coupler.
- 9. The surgical system according to claim 8, wherein a portion of the housing forms a handle, and the imaging light source and the visible light source are disposed within the handle.
- 10. The surgical system according to claim 1, wherein the sample arm optical assembly includes polarization optics to allow for birefringence.
- 11. The surgical system according to claim 1, wherein the sample arm optical assembly and the reference arm optical assembly are configured for optical coherence microscopy using a high numerical aperture.
- 12. A surgical system comprising:
 - a first jaw member and a second jaw member each having a tissue contacting surface, at least one of the first or second jaw members movable between a first spaced-apart position and a second grasping position, wherein the first jaw member includes therein:
 - a sample arm optical assembly configured to illuminate tissue grasped between the first and second jaw members with a first light beam, and receive from the tissue a portion of the first light beam reflected off the tissue,
 - a reference arm optical assembly comprising a reference mirror configured to reflect a portion of a second light beam, and
 - an optical coupler optically coupled to the sample arm optical assembly and the reference arm optical assembly, wherein the optical coupler is configured to:
 - provide the first light beam from a first output of the optical coupler to the sample arm optical assembly,
 - receive, at the first output, the reflected portion of the first light beam from the sample arm optical assembly,
 - provide the second light beam from a second output of the optical coupler to the reference arm optical assembly,
 - receive, at the second output, the reflected portion of the second light beam from the reference arm optical assembly, and
 - provide a third light beam from a third output of the optical coupler, the third light beam based on the reflected portions of the first and second light beams received at the first and second outputs respectively; and
 - a processor configured to process a light detection signal and obtain interference pattern data therefrom, wherein the light detection signal is based on the third light beam.
- 13. The surgical system according to claim 12, wherein the processor is further configured to generate an image signal based on the interference pattern data and transmit the image signal to a display device.
- 14. The surgical system according to claim 12, further comprising a light detector configured to detect the third light beam and generate the light detection signal therefrom.
- 15. The surgical system according to claim 14, further comprising:
 - 65 an energy source coupled to at least one of the first and second jaw members, the energy source configured to deliver energy to at least one of the first jaw member or

the second jaw member to seal the tissue grasped
between the first and second jaw members; and
a controller coupled to the light detector and the energy
source, the controller configured to control the energy
source based on at least one measured property of the
detected third light beam. 5

16. The surgical system according to claim 15, further
comprising a housing coupled to the first and second jaw
members, wherein at least one of the energy source and the
controller are disposed within the housing. 10

* * * * *