

(19)



(11)

EP 3 118 433 B1

(12)

EUROPEAN PATENT SPECIFICATION

(45) Date of publication and mention of the grant of the patent:
31.08.2022 Bulletin 2022/35

(51) International Patent Classification (IPC):
F02B 19/10^(2006.01) F02B 19/12^(2006.01)
F02M 21/02^(2006.01)

(21) Application number: **15176983.3**

(52) Cooperative Patent Classification (CPC):
F02M 21/0275; F02B 19/1014; F02B 19/12;
F02M 21/0281; F02P 13/00; Y02T 10/12;
Y02T 10/30

(22) Date of filing: **16.07.2015**

(54) **PRE-COMBUSTION CHAMBER ASSEMBLY FOR INTERNAL COMBUSTION ENGINES**

VORKAMMERANORDNUNG FÜR VERBRENNUNGSMOTOREN

ENSEMBLE CHAMBRE DE PRÉCOMBUSTION POUR MOTEURS À COMBUSTION INTERNE

(84) Designated Contracting States:
AL AT BE BG CH CY CZ DE DK EE ES FI FR GB
GR HR HU IE IS IT LI LT LU LV MC MK MT NL NO
PL PT RO RS SE SI SK SM TR

(72) Inventor: **MAIER, Thomas**
68309 Mannheim (DE)

(43) Date of publication of application:
18.01.2017 Bulletin 2017/03

(74) Representative: **Novagraaf Group**
Chemin de l'Echo 3
1213 Onex/ Geneva (CH)

(73) Proprietor: **Caterpillar Energy Solutions GmbH**
68167 Mannheim (DE)

(56) References cited:
EP-A1- 0 377 265 EP-A1- 2 700 796
EP-A1- 3 176 423 WO-A1-2013/096979
US-A- 3 406 667 US-A- 5 230 313

Note: Within nine months of the publication of the mention of the grant of the European patent in the European Patent Bulletin, any person may give notice to the European Patent Office of opposition to that patent, in accordance with the Implementing Regulations. Notice of opposition shall not be deemed to have been filed until the opposition fee has been paid. (Art. 99(1) European Patent Convention).

EP 3 118 433 B1

Description

Technical Field

[0001] The present disclosure generally relates to a pre-combustion chamber assembly for internal combustion engines. The present disclosure relates further to an internal combustion engine and a pre-combustion chamber section. The present disclosure relates further to a method for operating an internal combustion engine operating at least partly on gaseous fuel.

Background

[0002] Internal combustion engines running, for example, at least in part on gaseous fuel usually need an ignition device (also referred to as precombustion chamber assembly) to ignite the mixture of gaseous fuel and air. A pre-combustion chamber assembly including a pre-combustion chamber may have a spark plug partially protruding into the pre-combustion chamber. Such a pre-combustion chamber assembly may further include a fuel supply for supplying some amount of fuel into the pre-combustion chamber. Upon ignition of the air/fuel mixture within the pre-combustion chamber, the flames may advance through orifices provided in the pre-combustion chamber into the main combustion chamber, where the flames may ignite the main amount of fuel and air for operating the internal combustion engine.

[0003] US 8,028,674 B2 discloses a fuel processor apparatus and method. A fuel nozzle includes at least one port for receiving fuel, a sidewall forming ports for introducing fuel into a pre-combustion chamber, and a plurality of conduits formed between the first end and the sidewall.

[0004] US 7,451,727 B2 discloses an engine comprising a working cylinder provided with a piston, a pre-ignition chamber provided with a spark plug, and a combustion chamber which are connected to a compressor cylinder by channels. The compressor cylinder is provided with fuel and air supplying channels arranged in the top section thereof and with a piston and shutoff valve.

[0005] Further pre-combustion chamber assemblies are known from, for example, US 4,119,065 A, US 3,970,053 A, US 6,513,483 B2, EP 0 338 882 B1, AT 510 435 B1, and WO 2009/109694 A2.

[0006] US 3,406,667 A discloses a stratified charge ignition system for a spark type internal combustion engine. The apparatus comprises a precombustion chamber coupled in fluid communication with each primary combustion chamber of the engine in place of the spark plug normally coupled thereto. Carburetion means supply a relatively rich fuel-air mixture to each precombustion chamber. A spark ignition means effects the ignition of the fuel air mixture supplied to each of said chambers in timed sequence to the operation of the engine. Fluid communication between each precombustion chamber and the primary combustion chamber coupled thereto is pro-

vided by an orifice comprising a Borda mouthpiece opening into the precombustion to define an imperforate lip extending thereto. A nozzle of substantially truncated conical shape extends from the mouthpiece in diverging relationship relative thereto and opening into the primary combustion chamber.

[0007] US 5 230 313 A refers to a cylinder head having a conventional spark plug therein, for engine start-up, and having a precombustion chamber unit mounted therein as well, for cleaner, more stable normal running of the engine. The method defines the reaming out of spark plug apertures in the head to accommodate the installation of the precombustion chamber unit. The assembly disclosed herein comprises a sleeve with a plurality of fluid-accommodating ports formed in a pre-combustion chamber, and these ports are arranged in parallel and radially aligned in the upper section. But only one orificial without a plurality of flow transfer passages has an outlet located in the flame nozzle in the lower section. An offset between a main portion having a main portion central axis and a longitudinal central axis of the pre-combustion chamber upper and lower sections is not mentioned.

[0008] EP 2 700 796 A1 shows a pre-combustion chamber tip of an internal combustion engine exposed to high thermal and mechanical stress. It is disclosed to efficiently use an limited space by providing a first group of orifices extending at a first angle with respect to a center axis and a second group of orifices extending at a second angle with respect to the center axis, wherein the outlets of the orifices are arranged at a first axial position. The chamber disclosed herein is symmetrical.

[0009] EP0377265 and WO2013096979 disclose pre-combustion chamber assemblies.

[0010] The present disclosure is directed, at least in part, to improving or overcoming one or more aspects of prior systems.

Summary of the Disclosure

[0011] According to an aspect of the present disclosure, a pre-combustion chamber assembly for internal combustion engines operating at least partly on gaseous fuel and having a cylinder defining a main combustion chamber is disclosed. The pre-combustion chamber assembly extends along a longitudinal central axis and comprises a pre-combustion chamber upper section extending along the longitudinal central axis and including an ignition device accommodation portion configured to accommodate an ignition device and a fuel supply accommodation portion for accommodating a fuel supply device, the fuel supply accommodation portion having a central axis extending in parallel to the longitudinal central axis with a predetermined offset. The precombustion chamber assembly further comprises a pre-combustion chamber lower section extending along the longitudinal central axis and connected to the pre-combustion chamber upper section. The pre-combustion chamber lower

section includes a plurality of flow transfer passages. The pre-combustion chamber assembly further comprises a pre-combustion chamber delimited within the pre-combustion chamber upper section and the precombustion chamber lower section, and fluidly connectable to the main combustion chamber via the plurality of flow transfer passages. The precombustion chamber includes a main portion having a main portion central axis extending in parallel to the longitudinal central axis with a predetermined offset. The pre-combustion chamber assembly further comprises an ignition device mounted to the ignition device accommodation portion and configured to initiate a combustion event at an ignition point within the main portion. The ignition point lies substantially on the main portion central axis.

[0012] According to another aspect of the present disclosure, an internal combustion engine operating at least partly on gaseous fuel comprises a cylinder defining a main combustion chamber, a cylinder head delimiting the main combustion chamber at a top end, and a pre-combustion chamber assembly according to the present disclosure. The pre-combustion chamber assembly is mounted to the cylinder head and configured to initiate a main combustion event within the main combustion chamber.

[0013] According to another aspect of the present disclosure, a method for operating an internal combustion engine operating at least partly on gaseous fuel and that includes a main combustion chamber and a pre-combustion chamber assembly including a longitudinal central axis and a pre-combustion chamber with a main portion having a main portion central axis extending substantially in parallel to the longitudinal central axis with a predetermined offset is disclosed. The pre-combustion chamber is fluidly connected to the main combustion chamber via a plurality of flow transfer passages. The disclosed method comprises the steps of supplying a combustion mixture into the main portion via the plurality of flow transfer passages during a compression stroke of the internal combustion engine, and igniting the combustion mixture at an ignition point within the main portion. The ignition point lies on the main portion central axis. The disclosed method further may comprise the step of supplying a predetermined amount of gaseous fuel into the main portion for enriching the main portion with gaseous fuel by means of a fuel supply accommodation portion included in a pre-combustion chamber upper section of the pre-combustion chamber assembly and configured to accommodate a fuel supply device, the fuel supply accommodation portion having a central axis extending in parallel to the longitudinal central axis with a predetermined offset.

[0014] According to another aspect of the present disclosure, a precombustion chamber lower section of a pre-combustion chamber assembly as disclosed herein includes a pre-combustion chamber lower section body extending along the longitudinal central axis and is configured to be mounted to the pre-combustion chamber upper section of the pre-combustion chamber assembly

disclosed herein. A pre-combustion chamber tip connects to the precombustion chamber lower section body and includes a plurality of flow transfer passages, the pre-combustion chamber tip extending along the longitudinal central axis. A pre-combustion chamber has a main portion formed substantially within the connecting portion and a riser passage fluidly connected to the main portion and formed substantially within the pre-combustion chamber tip, the main portion having a main portion central axis extending in parallel to the longitudinal central axis with a predetermined offset, such that, in a circumferential direction about the longitudinal central axis, the pre-combustion chamber lower section includes a varying radial wall thickness.

[0015] Other features and aspects of this disclosure will be apparent from the following description and the accompanying drawings.

Brief Description of the Drawings

[0016] The accompanying drawings, which are incorporated herein and constitute a part of the specification, illustrate exemplary embodiments of the disclosure and, together with the description, serve to explain the principles of the disclosure. In the drawings:

Fig. 1 is a diagrammatic cross-sectional view of an internal combustion engine with a pre-combustion chamber assembly installed in a cylinder head of the internal combustion engine;

Fig. 2 is a diagrammatic cross-sectional view of the cylinder head with an installed pre-combustion chamber assembly shown in greater detail;

Fig. 3 is a partial cut view of the pre-combustion chamber assembly of Fig. 2; and

Fig. 4 is a cross-sectional view of the pre-combustion chamber assembly of Fig. 3 taken along line IV - IV of Fig. 3.

Detailed Description

[0017] The following is a detailed description of exemplary embodiments of the present disclosure. The exemplary embodiments described therein and illustrated in the drawings are intended to teach the principles of the present disclosure, enabling those of ordinary skill in the art to implement and use the present disclosure in many different environments and for many different applications. Therefore, the exemplary embodiments are not intended to be, and should not be considered as, a limiting description of the scope of patent protection. Rather, the scope of patent protection shall be defined by the appended claims.

[0018] The present disclosure is based at least in part on the realization that asymmetrically arranging a pre-combustion chamber within a precombustion chamber assembly with respect to a longitudinally axis of the pre-combustion chamber assembly and providing a ignition

point lying on a central axis of the pre-combustion chamber may support in stabilizing a combustion event within the pre-combustion chamber. In particular, the combustion event is provided symmetrically within the pre-combustion chamber and, hence, extinguishing of flames generated during the combustion event may be prevented due to a uniform distance of the ignition point to the inner walls of the combustion chamber. More particularly, it is preferable that the distance between the ignition point and the inner walls of the combustion chamber is as great as possible for preventing the flames from being extinguished too early during the ignition event. The better the combustion within the pre-combustion chamber with respect to efficiency, the better the combustion within the main combustion chamber with respect to efficiency.

[0019] Within the meaning of the present disclosure, a "central axis" describes an axis of symmetry of a respective element or portion. That is that an element or portion having a "central axis" is substantially symmetrical with respect to said axis. In particular, an element or portion having a "central axis" is rotationally symmetrical with respect to said axis.

[0020] Referring now to the drawings, an exemplary embodiment of an internal combustion engine 10 is illustrated in Fig. 1. The internal combustion engine 10 may include features not shown, such as fuel systems, air systems, cooling systems, peripheries, drivetrain components, turbochargers, etc. For the purpose of the present disclosure, the internal combustion engine 10 is considered as a four-stroke gaseous fuel internal combustion engine. One skilled in the art will recognize, however, that the gaseous fuel internal combustion engine 10 may be any type of engine (two-stroke, turbine, gas, diesel, natural gas, propane, etc.) that would utilize a pre-combustion chamber. Furthermore, the internal combustion engine 10 may be of any size, with any number of cylinders, and in any configuration ("V", in-line, radial, etc.). The internal combustion engine 10 may be used to power any machine or other device, including locomotive applications, on-highway trucks or vehicles, off-highway trucks or machines, earth moving equipment, generators, aerospace applications, marine applications, pumps, stationary equipment, or other engine powered applications.

[0021] The internal combustion engine 10 may include an engine block 12 having a plurality of cylinders 14 (one of which is illustrated in Fig. 1). A piston 16 may be slidably disposed within the cylinder (or cylinder liner) 14 to reciprocate between a top dead center position and a bottom dead center position. A connecting rod 18 may connect the piston 16 to an eccentric crankpin 20 of a crankshaft 22 such that reciprocating motion of the piston may result in rotation of the crankshaft 22.

[0022] The internal combustion engine 10 may also include a cylinder head 24 engaged with the engine block 12 to cover the cylinder 14, thereby delimiting a main combustion chamber 26. The cylinder head 24 may define intake and exhaust openings 28 that may allow intake

gases into the main combustion chamber 26 and exhaust gases out of the main combustion chamber 26, respectively. Engine valves 30 may be positioned to selectively open and close the openings 28. Each cylinder 14 may include multiple intake and exhaust openings 28.

[0023] The internal combustion engine 10 may include a series of valve actuation assemblies 40 (one of which is illustrated in Fig. 1). The multiple valve actuation assemblies 40 may be provided per cylinder 14. For example, one valve actuation assembly may be used to open and close the intake valves and another valve actuation assembly may be provided to open and close the exhaust valves.

[0024] The valve actuation assembly 40 may include a rocker arm 46. The rocker arm 46 may be pivotally mounted in the cylinder head 24 and may attach to the engine valves 30 at one end and may attach to a push rod 48 at the other end. Oscillation of rocker arm 46 about its pivot point 50 may cause the valves 30 to move between an open position and a closed position. The valve actuation assembly 40 may also include valve springs 52 that may bias the valves 30 toward the closed position (i.e. closing the intake and exhaust openings 28).

[0025] The other end of the push rod 48 may engage a lifter 54 which may engage a camshaft 56. The camshaft 56 may operatively engage the crankshaft 22. The camshaft 56 may be connected with crankshaft 22 in any manner readily apparent to one skilled in the art where rotation of the crankshaft 22 may result in rotation of the camshaft 56. For example, camshaft 56 may be connected to crankshaft 22 through a gear train (not shown).

[0026] As shown in Fig. 1, a first cam lobe 58 may be disposed on the camshaft 56 to engage the lifter 54. One skilled in the art may recognize that the camshaft 56 may include additional cam lobes to engage with other lifters in order to actuate additional engine valves.

[0027] The internal combustion engine 10 may also include a precombustion chamber assembly 60 (also referred to as pre-combustion chamber ignition device), which is positioned within the cylinder head 24 between the valves 30. The pre-combustion chamber assembly 60 may be configured in a variety of ways. Any assembly capable of being positioned in the cylinder head 24 to support a combustion event outside of the main combustion chamber 26, and direct the combustion into the main combustion chamber 26 may be used.

[0028] With reference to Fig. 2, the pre-combustion chamber assembly 60 of Fig. 1 is shown in greater detail. The pre-combustion chamber assembly 60 defining a longitudinal central axis 63 may extend from the cylinder head 24 into the main combustion chamber 26. In the depicted embodiment, the precombustion chamber assembly 60 comprises a pre-combustion chamber upper section 70 and a pre-combustion chamber lower section 80 detachably mounted to the pre-combustion chamber upper section 70. In some further embodiments, the pre-combustion chamber lower section 80 may be mounted to the precombustion chamber upper section 70 via, for

example, welding or soldering.

[0029] As illustrated in Fig. 2, the pre-combustion chamber upper section 70 is disposed above the pre-combustion chamber lower section 80. In Fig. 2, a separation between the pre-combustion chamber upper section 70 and the pre-combustion chamber lower section 80 is indicated by a dashed line C. In some embodiments, the pre-combustion chamber assembly 60 may be a one-piece element manufactured by, for example, metal sintering, moulding, or any other suitable process.

[0030] The pre-combustion chamber assembly 60 is attached to the cylinder head 24 via, for example, a fastening device 61. In the assembled state, the fastening device 61 may at least partially press the pre-combustion chamber assembly 60 towards the main combustion chamber 26 (in Fig. 2 in a downward direction). On the opposite side, the pre-combustion chamber assembly 60 contacts a flange 114, such that the pre-combustion chamber upper and lower sections 70, 80 are at least partially compressed, thereby forming a robust device. In this state, the pre-combustion chamber upper and lower sections 70, 80 are relatively fixed to one another with respect to axial displacement and rotation. The pre-combustion chamber upper section 70 may be generally cylindrical and may be made of any suitable material.

[0031] The flange 114 is sealed against the main combustion chamber 26. The flange 114 extends transversely relative to the longitudinal central axis 63 and is provided to seal against a sealing surface 116 provided in the cylinder head 24 to prevent leakage between the main combustion chamber 26 and first and second cooling fluid passages 32, 34.

[0032] The pre-combustion chamber upper section 70 is configured to accommodate an ignition device, such as, for example, a spark plug 62 therein such that a sparking end of the spark plug 62 at least partially protrudes into a pre-combustion chamber 90 provided within the pre-combustion chamber assembly 60. The spark plug 62 in the context of this invention may mean any suitable ignition device available in the prior art, such as, for instance, a plasma generator, a laser ignition device, a pilot fuel injector, a glow plug, or a glow pencil.

[0033] The pre-combustion chamber lower section 80 is generally cylindrical and is mountable to the pre-combustion chamber upper section 70. Preferably, the pre-combustion chamber lower section 80 may be detachably mountable to the pre-combustion chamber upper section 70. This may allow replacing of, for example, the pre-combustion chamber lower section 80 by a new pre-combustion chamber lower section in the case of wear of the pre-combustion chamber lower section 80, especially in the case of wear of a pre-combustion chamber tip 81 including a plurality of flow transfer passages 83. For instance, after a usage time of, for example, about 15.000 hours of engine operation, the pre-combustion chamber lower section 80 may be replaced. The pre-combustion chamber lower section 80 may be cast to the general configuration and subsequently machined to final dimen-

sions where required. In some embodiments, the pre-combustion chamber lower section 80 may be machined out of a solid material block. In some further embodiments, the pre-combustion chamber lower section 80 may be sintered, or manufactured in any other suitable way known in the art.

[0034] The pre-combustion chamber upper section 70 may have a stepped bore 64 that may be adapted to receive the spark plug 62. The stepped bore 64 may have an ignition device accommodation portion 66, such as a mounting bore adapted to receive an end of the spark plug 62. The ignition device accommodation portion 66 may include a thread adapted to mate with threads on the end of the spark plug 62. The stepped bore 64 may define a sealing surface 65 that may be adapted to sealingly contact the spark plug 62. The ignition device accommodation portion 66 may have any suitable configuration for accommodating the ignition device.

[0035] Referring to Fig. 3, a partial cut view of the pre-combustion chamber assembly 60 is illustrated. The pre-combustion chamber lower section 80 includes the pre-combustion chamber tip 81 which is generally cylindrical and which may at least partially protrude into the main combustion chamber 26 through a bore 120 provided in the cylinder head 24 (see Fig. 2).

[0036] The pre-combustion chamber upper section 70 and the pre-combustion chamber lower section 80 each define at least a portion of the pre-combustion chamber 90. Particularly, the pre-combustion chamber lower section 80 defines at least a portion of the pre-combustion chamber 90, and the pre-combustion chamber upper section 70 defines a remaining portion of the pre-combustion chamber 90. Thus, the pre-combustion chamber upper and lower sections 70, 80 together define the pre-combustion chamber 90.

[0037] The pre-combustion chamber 90 includes a main portion 92, a riser passage 94, and an intermediate portion 96 fluidly interconnected between the main portion 92 and the riser passage 94. In Fig. 3, the main portion 92, the riser passage 94, and the intermediate portion 96 are indicated in dash-two-dot lines. As shown in Fig. 2, the electrode end of the spark plug 62 at least partially protrudes into the pre-combustion chamber 90, particularly into the main portion 92.

[0038] The pre-combustion chamber tip 81 having a substantially domelike shape includes a plurality of spaced apart, particularly radially oriented flow transfer passages 83. In some embodiments, the plurality of flow transfer passages 83 may extend tangentially with respect to a circle about the longitudinal axis 63.

[0039] The plurality of flow transfer passages 83 fluidly connects the pre-combustion chamber 90, particularly the riser passage 94, to the main combustion chamber 26. The plurality of flow transfer passages 83 is configured to direct burning fuel, for example, expanding gases from the pre-combustion chamber 90 in a predetermined pattern into the main combustion chamber 26 and to direct an air/fuel mixture from the main combustion chamber

26 into the pre-combustion chamber 90.

[0040] The pre-combustion chamber upper section 70 includes a precombustion chamber upper section body 72 and a fuel supply accommodation portion 74 fluidly connected to the pre-combustion chamber 90 via a fuel supply channel 76. The fuel supply accommodation portion 74 is further fluidly connected to a fuel system (not explicitly shown in the drawings) including, for example, a fuel reservoir, fuel pumps, control valves, and further elements configured to provide fuel, such as, for example, gaseous fuel, to the precombustion chamber 90. In some embodiments, the pre-combustion chamber upper section 70 may include more than one fuel supply accommodation portion 74. The fuel supply accommodation portion 74 is configured to accommodate, for example, a gaseous fuel valve (not shown in the drawings) and to supply a predetermined amount of gaseous fuel into the pre-combustion chamber 90. The gaseous fuel valve may be configured to control the supply of gaseous fuel into the pre-combustion chamber 90.

[0041] As shown, the fuel supply accommodation portion 74 includes a central axis 75 extending substantially in parallel to the longitudinal central axis 63 with a predetermined offset 77. In some embodiments, the central axis 75 of the fuel supply accommodation portion 74 may extend obliquely and inclined with respect to the longitudinal central axis 63.

[0042] The predetermined amount of gaseous fuel supplied into the main portion 92 may be configured to at least locally enrich the combustion mixture within the pre-combustion chamber 90, particularly within the main portion 92.

[0043] The pre-combustion chamber upper section 70 is mountable to the pre-combustion chamber lower section 80 via, for instance, welding, soldering, screwing, bolting, form-fitting, or any other suitable fixing means. The precombustion chamber lower section 80 includes a pre-combustion chamber lower section body 82 and an annular protrusion 84 configured to engage and match with an annular recess 73 of the pre-combustion chamber upper section body 72. For example, the pre-combustion chamber upper and lower sections 70, 80 are mounted to one another via a thread (not shown in the drawings) provided on an inner circumferential surface of the annular protrusion 84 and on an outer circumferential surface of the annular recess 73, respectively. In some embodiments, the pre-combustion chamber upper and lower sections 70, 80 are mounted to one another by welding, particularly via a laser beam weld extending about the outer circumference of the pre-combustion chamber upper and lower sections 70, 80.

[0044] With additional reference to Fig. 4, it can be seen that the main portion 92 of the pre-combustion chamber 90 is substantially cylindrical with a substantially circular cross-section and has a main portion central axis 93 extending substantially in parallel to the longitudinal central axis 63 with a predetermined offset 91. Thus, the main portion 92 is not centrally and not symmetrically

provided in the pre-combustion chamber upper and lower sections 70, 80 with respect to the longitudinal central axis 63. In further embodiments, the substantially cylindrical main portion 92 may have any other suitable cross-sectional shape, such as, for instance, a rectangular, square, and oval.

[0045] As also shown in Fig. 4, the riser passage 94 is substantially cylindrical with a substantially circular cross-section and has a riser passage central axis 95 extending coaxially with respect to the longitudinal central axis 63. Thus, the riser passage 94 is centrally and symmetrically provided in the precombustion chamber lower section 80 with respect to the longitudinal central axis 63. As shown in the embodiment of Figs. 3 and 4, the riser passage central axis 95 is substantially coaxial with respect to the longitudinal central axis 63, that is that the riser passage central axis 95 is coincident with the longitudinal axis 63. The riser passage central axis 95 extends substantially in parallel to the main portion central axis 93 with the predetermined offset 91.

[0046] In some embodiments, the riser passage central axis 95 may extend obliquely and inclined with respect to the longitudinal central axis 63. In such case, a tumble flow imparted into the combustion mixture flowing from the main combustion chamber 26 into the pre-combustion chamber 90 during a compression stroke of the internal combustion engine 10 may be enhanced.

[0047] As indicated in Fig. 3, the ignition device accommodation portion 66 includes a central axis 67 extending substantially in parallel to the longitudinal central axis 63 and coaxially with respect to the main portion central axis 93. That is that the central axis 67 is coincident with the longitudinal central axis 63. Specifically, the spark plug 62 is mounted to the ignition device accommodation portion 66 along the central axis 67 (see Fig. 2).

[0048] The spark plug 62 is configured to generate a spark within the main portion 92 for initiating a combustion event within the main portion 92 at an ignition point 99. As shown in Figs. 3 and 4, the ignition point 99 lies on both the central axis 67 of the ignition device accommodation portion 66 and the main portion central axis 93 of the main portion 92. Thus, a radial distance 97 between the ignition point 99 and an inner wall of the pre-combustion chamber 90 is equal in each radial direction with respect to the main portion central axis 93. Hence, the ignition point 99 is centrally provided within the main portion 92 with respect to the main portion central axis 93.

[0049] In some embodiments, the central axis 67 of the ignition device accommodation portion 66 may extend obliquely with respect to the main portion central axis 93 and the longitudinal central axis 63. In particular, the spark plug 62 may extend obliquely with respect to the longitudinal central axis 63 such that the ignition point 99 lies on the main portion central axis 93 and, hence, centrally within the main portion 92 in a radial direction. For example, the central axis 67 may extend obliquely with respect to the longitudinal central axis 63 with an angle between about 0° and about 30°.

[0050] In some embodiments, the ignition point 99 may further be centrally arranged within the main portion 92 with respect to an axial direction of the main portion central axis 93. That is that the ignition point 99 is centrally disposed between an upper end of the main portion 92 and a lower end of the main portion 92.

[0051] Referring to Fig. 4, a cut view of the pre-combustion chamber assembly 60 taken along line IV - IV of Fig. 3 is shown. In Fig. 4, it can be seen that the main portion 92 includes a substantially cylindrical shape with a substantially circular cross-section. The ignition point 99 lying on the main portion central axis 93 is, thus, centrally disposed within the main portion 92 and has a radial distance 97 to the inner wall of the pre-combustion chamber 90 that corresponds substantially to the radius of the main portion 92.

[0052] As further shown in Fig. 4, the pre-combustion chamber lower section body 82 includes, in a circumferential direction about the longitudinal central axis 63, a varying radial wall thickness. That is that the radial wall thickness of the pre-combustion chamber lower section body 82 with respect to the longitudinal central axis 63 is smaller on the left side in Fig. 4 than on the right side in Fig. 4 (see also Fig. 3).

Industrial Applicability

[0053] In the following, operation of the internal combustion engine 10 comprising an exemplary disclosed pre-combustion chamber assembly is described with respect to the drawings.

[0054] During operation of the internal combustion engine 10, especially during a compression stroke of one of the cylinders 14, at least some amount of an air/fuel mixture provided to the cylinder 14 through the engine valves 30 during an intake stroke is forced into the pre-combustion chamber 90 through the flow transfer passages 83. Then, for enriching the air/fuel mixture within the pre-combustion chamber 90 in order to support the ignition event, at least some amount of fuel, such as gaseous fuel, is provided into the pre-combustion chamber 90, particularly into the main portion 92, via the gaseous fuel valve mounted to the fuel supply accommodation portion 74, and fuel supply channel 76. The fuel supplied into the pre-combustion chamber 90 via the gaseous fuel valve and the fuel supply channel 76, respectively, may be supplied at a piston position in the vicinity of its bottom dead center. In some embodiments, the gaseous fuel supplied into the pre-combustion chamber 90 via the gaseous fuel valve and the fuel supply channel 76, respectively, may be supplied shortly before the ignition event is initiated.

[0055] Due to the arrangement of the fuel supply accommodation portion 74 and the fuel supply channel 76, the ignition device accommodation portion 66 needs to be displaced with respect to the longitudinal central axis 63 by the offset 91. Particularly, in view of the fuel supply accommodation portion 74 and the fuel supply channel

76, there may be not enough space at the pre-combustion chamber upper section 70 for centrally providing the ignition device accommodation portion 66.

[0056] Then, the ignition device mounted to the ignition device accommodation portion 66 may initiate a combustion event at the ignition point 99 lying on the main portion central axis 93 and, hence, in a central region of the main portion 92. Due to the central position of the ignition point 99, a uniform and symmetric combustion event may be initiated within the main portion 92, such that the flames generated during the ignition event may expand in all spatial directions in an improved manner. Moreover, the better the combustion within the pre-combustion chamber 90, the better the combustion within the main combustion chamber 26, in particular with respect to thermal efficiency.

[0057] Subsequently, the burning fuel may advance through the intermediate portion 96, the riser passage 94, and the plurality of flow transfer passages 83 into the main combustion chamber 26, where the main combustion mixture may be ignited.

[0058] The asymmetric arrangement of the pre-combustion chamber 90 with respect to the longitudinal central axis 63 may further have the effect of imparting at least partially a tumble flow into the combustion mixture pushed into the pre-combustion chamber 90 during a compression stroke. Specifically due to the asymmetric arrangement of the main portion 92 and the symmetric arrangement of the riser passage 94, the tumble flow may be imparted.

[0059] A tumble flow within the pre-combustion chamber 90, particularly within the main portion 92, may have the advantageous effect that it is substantially stable. For example, for a pre-combustion chamber main portion 92 symmetrically disposed within the pre-combustion chamber lower section 80 with a combustion point 99 being offset the central axis 93, the combustion mixture flow flowing into the main portion 92 may detach from the inner wall in all spatial directions. To the contrary, for a pre-combustion chamber main portion 92 asymmetrically disposed within the pre-combustion chamber lower section 80 with a combustion point 99 centrally provided within the main portion 92 (as shown in Fig. 3), the combustion mixture flow may detach in less spatial directions, that is that the combustion mixture flow may be substantially guided along at least a portion of the inner wall of the pre-combustion chamber 90 in a substantially defined manner.

Claims

1. A pre-combustion chamber assembly (60) for internal combustion engines (10) operating at least partly on gaseous fuel and having a cylinder (14) defining a main combustion chamber (26), the pre-combustion chamber assembly (60) extending along a longitudinal central axis (63) and comprising:

- a pre-combustion chamber upper section (70) extending along the longitudinal central axis (63), including an ignition device accommodation portion (66) configured to accommodate an ignition device (62) and including a fuel supply accommodation portion (74) for accommodating a fuel supply device, the fuel supply accommodation portion (74) having a central axis (75) extending in parallel to the longitudinal central axis (63) with a predetermined offset (77);
- a pre-combustion chamber lower section (80) extending along the longitudinal central axis (63) and connected to the pre-combustion chamber upper section (70), the pre-combustion chamber lower section (80) including a plurality of flow transfer passages (83);
- a pre-combustion chamber (90) delimited within the precombustion chamber upper section (70) and the pre-combustion chamber lower section (80) and fluidly connectable to the main combustion chamber (26) via the plurality of flow transfer passages (83), the pre-combustion chamber (90) including a main portion (92) having a main portion central axis (93) extending in parallel to the longitudinal central axis (63) with a predetermined offset (91); and
- an ignition device (62) mounted to the ignition device accommodation portion (66) and configured to initiate a combustion event at an ignition point (99) within the main portion (92), **characterized in that** the ignition point (99) lies substantially on the main portion central axis (93).
2. The pre-combustion chamber assembly (60) of claim 1, wherein the ignition device is a spark plug (62) for generating a spark at the ignition point (99), the spark plug (62) having a spark plug central axis (67) extending in parallel to the longitudinal central axis (63) with the predetermined offset (91).
 3. The pre-combustion chamber assembly (60) of any one of the preceding claims, wherein the ignition device (62) includes an ignition device central axis (67) extending coaxially with respect to the main portion central axis (93).
 4. The pre-combustion chamber assembly (60) of any one of the preceding claims, wherein the pre-combustion chamber (90) further includes a riser passage (94) fluidly interconnected between the main portion (92) and the plurality of flow transfer passages (83), the riser passage (94) having a riser passage central axis (95) extending in parallel to the main portion central axis (93) with the predetermined offset (91).
 5. The pre-combustion chamber assembly (60) of claim 4, wherein the riser passage central axis (95) extends coaxially with respect to the longitudinal central axis (63).
 6. The pre-combustion chamber assembly (60) of any one of the preceding claims, further comprising a gaseous fuel valve mounted to the fuel supply accommodation portion (74) along the fuel supply accommodation portion central axis (75).
 7. The pre-combustion chamber assembly (60) of claim 6, wherein the gaseous fuel valve is configured to supply a predetermined amount of gaseous fuel to the main portion (92) via a fuel supply channel (76) fluidly connecting the fuel supply accommodation portion (74) to the main portion (92).
 8. An internal combustion engine (10) operating at least partly on gaseous fuel, the internal combustion engine (10) comprising:
 - a cylinder (14) defining a main combustion chamber (26);
 - a cylinder head (24) delimiting the main combustion chamber (26) at a top end; and
 - a pre-combustion chamber assembly (60) according to any one of the preceding claims, the pre-combustion chamber assembly (60) being mounted to the cylinder head (24) and configured to initiate a main combustion event within the main combustion chamber (26).
 9. A method for operating an internal combustion engine (10) operating at least partly on gaseous fuel and that includes a main combustion chamber (26) and a pre-combustion chamber assembly (60) including a longitudinal central axis (63) and a pre-combustion chamber (90) with a main portion (92) having a main portion central axis (93) extending substantially in parallel to the longitudinal central axis (63) with a predetermined offset (91), the pre-combustion chamber (90) being fluidly connected to the main combustion chamber (26) via a plurality of flow transfer passages (83), the method comprising:
 - supplying a combustion mixture into the main portion (92) via the plurality of flow transfer passages (83) during a compression stroke of the internal combustion engine (10);
 - igniting the combustion mixture at an ignition point (99) within the main portion (92), and
 - supplying a predetermined amount of gaseous fuel into the main portion (92) for enriching the main portion (92) with gaseous fuel by means of a fuel supply accommodation portion (74) included in a pre-combustion chamber upper section (70) of the pre-combustion chamber assembly (60) and configured to accommodate a fuel supply device, the fuel supply accommodation

portion (74) having a central axis (75) extending in parallel to the longitudinal central axis (63) with a predetermined offset (77), **characterized in that** the ignition point (99) lies on the main portion central axis (93).

10. The method of claim 9, wherein igniting the combustion mixture includes generating a spark by a spark plug (62) having a spark plug central axis (67) extending coaxially with respect to the main portion central axis (93).
11. The method of any one of claims 9 to 10, further comprising directing burning fuel through a riser passage (94) fluidly interconnected between the main portion (92) and the plurality of flow transfer passages (83), the riser passage (94) having a riser passage central axis (95) extending substantially in parallel to the main portion central axis (93).

Patentansprüche

1. Vorkammeranordnung (60) für Verbrennungsmotoren (10), die zumindest teilweise mit gasförmigem Kraftstoff betrieben werden und einen Zylinder (14) aufweisen, der eine Hauptkammer (26) definiert, wobei sich die Vorkammeranordnung (60) entlang einer Längsmittelachse (63) erstreckt und umfasst:

einen oberen Vorkammerabschnitt (70), der sich entlang der Längsmittelachse (63) erstreckt, einen Zündvorrichtungsaufnahmeabschnitt (66) einschließt, der konfiguriert ist, um eine Zündvorrichtung (62) aufzunehmen und einen Kraftstoffzufuhrabschnitt (74) zum Aufnehmen einer Kraftstoffzufuhrvorrichtung einschließt, wobei der Kraftstoffzufuhrabschnitt (74) eine Mittelachse (75) aufweist, die sich parallel zur Längsmittelachse (63) mit einem vorbestimmten Versatz (77) erstreckt;

einen unteren Vorkammerabschnitt (80), der sich entlang der Längsmittelachse (63) erstreckt und mit dem oberen Vorkammerabschnitt (70) verbunden ist, wobei der untere Vorkammerabschnitt (80) eine Vielzahl von Strömungsübertragungskanälen (83) einschließt;

eine Vorkammer (90), die innerhalb des oberen Vorkammerabschnitts (70) und des unteren Vorkammerabschnitts (80) begrenzt ist und über die Vielzahl von Strömungsübertragungskanälen (83) mit der Hauptkammer (26) fluidisch verbindbar ist, wobei die Vorkammer (90) einen Hauptabschnitt (92) einschließt, der eine Hauptabschnittmittelachse (93) aufweist, die sich parallel zur Längsmittelachse (63) mit einem vorbestimmten Versatz (91) erstreckt; und

eine Zündvorrichtung (62), die an dem Zündvorrichtungsaufnahmeabschnitt (66) montiert ist und konfiguriert ist, um ein Verbrennungseignis an einem Zündpunkt (99) innerhalb des Hauptabschnitts (92) einzuleiten, **dadurch gekennzeichnet, dass** der Zündpunkt (99) im Wesentlichen auf der Hauptabschnittmittelachse (93) liegt.

2. Vorkammeranordnung (60) nach Anspruch 1, wobei die Zündvorrichtung eine Zündkerze (62) zum Erzeugen eines Funkens am Zündpunkt (99) ist, wobei die Zündkerze (62) eine Zündkerzenmittelachse (67) aufweist, die sich parallel zur Längsmittelachse (63) mit dem vorbestimmten Versatz (91) erstreckt.

3. Vorkammeranordnung (60) nach einem der vorstehenden Ansprüche, wobei die Zündvorrichtung (62) eine Zündvorrichtungsmittelachse (67) einschließt, die sich koaxial in Bezug auf die Hauptabschnittmittelachse (93) erstreckt.

4. Vorkammeranordnung (60) nach einem der vorstehenden Ansprüche, wobei die Vorkammer (90) ferner einen Steigkanal (94) einschließt, der zwischen dem Hauptabschnitt (92) und der Vielzahl von Strömungsübertragungskanälen (83) fluidisch verbunden ist, wobei der Steigkanal (94) eine Steigkanalmittelachse (95) aufweist, die sich parallel zur Hauptabschnittmittelachse (93) mit dem vorbestimmten Versatz (91) erstreckt.

5. Vorkammeranordnung (60) nach Anspruch 4, wobei sich die Steigkanalmittelachse (95) koaxial in Bezug auf die Längsmittelachse (63) erstreckt.

6. Vorkammeranordnung (60) nach einem der vorstehenden Ansprüche, ferner umfassend ein Ventil für gasförmigen Kraftstoff, das an dem Kraftstoffzufuhrabschnitt (74) entlang der Mittelachse (75) des Kraftstoffzufuhrabschnitts montiert ist.

7. Vorkammeranordnung (60) nach Anspruch 6, wobei das Ventil für gasförmigen Kraftstoff konfiguriert ist, um über einen Kraftstoffzufuhrkanal (76), der den Kraftstoffzufuhrabschnitt (74) fluidisch mit dem Hauptabschnitt (92) verbindet, dem Hauptabschnitt (92) eine vorbestimmte Menge an gasförmigem Kraftstoff zuzuführen.

8. Verbrennungsmotor (10), der zumindest teilweise mit gasförmigem Kraftstoff betrieben wird, wobei der Verbrennungsmotor (10) umfasst:

einen Zylinder (14), der eine Hauptkammer (26) definiert;
einen Zylinderkopf (24), der die Hauptkammer

(26) an einem oberen Ende begrenzt; und eine Vorkammeranordnung (60) nach einem der vorstehenden Ansprüche, wobei die Vorkammeranordnung (60) an dem Zylinderkopf (24) montiert ist und konfiguriert ist, um ein Hauptverbrennungsereignis innerhalb der Hauptkammer (26) einzuleiten.

9. Verfahren zum Betreiben eines Verbrennungsmotors (10), der zumindest teilweise mit einem gasförmigen Kraftstoff betrieben wird und eine Hauptkammer (26) und eine Vorkammeranordnung (60) einschließt, die eine Längsmittelachse (63) und eine Vorkammer (90) mit einem Hauptabschnitt (92) einschließt, der eine Hauptabschnittmittelachse (93) aufweist, die sich im Wesentlichen parallel zur Längsmittelachse (63) mit einem vorbestimmten Versatz (91) erstreckt, wobei die Vorkammer (90) über eine Vielzahl von Strömungsübertragungskanälen (83) mit der Hauptkammer (26) fluidisch verbunden ist, wobei das Verfahren umfasst:

Zuführen eines Verbrennungsgemischs in den Hauptabschnitt (92) über die Vielzahl von Strömungsübertragungskanälen (83) während eines Kompressionshubs des Verbrennungsmotors (10);

Zünden des Verbrennungsgemischs an einem Zündpunkt (99) innerhalb des Hauptabschnitts (92)

und

Zuführen einer vorbestimmten Menge an gasförmigem Kraftstoff in den Hauptabschnitt (92) zum Anreichern des Hauptabschnitts (92) mit gasförmigem Kraftstoff mittels eines Kraftstoffzufuhraufnahmeabschnitts (74), der in einem oberen Vorkammerabschnitt (70) der Vorkammeranordnung (60) eingeschlossen ist und konfiguriert ist, um eine Kraftstoffzufuhrvorrichtung aufzunehmen, wobei der Kraftstoffzufuhraufnahmeabschnitt (74) eine Mittelachse (75) aufweist, die sich parallel zur Längsmittelachse (63) mit einem vorbestimmten Versatz (77) erstreckt, **dadurch gekennzeichnet, dass** der Zündpunkt (99) auf der Hauptabschnittmittelachse (93) liegt.

10. Verfahren nach Anspruch 9, wobei das Zünden des Verbrennungsgemischs das Erzeugen eines Funken durch eine Zündkerze (62) mit einer Zündkerzenmittelachse (67) einschließt, die sich koaxial in Bezug auf die Hauptabschnittmittelachse (93) erstreckt.
11. Verfahren nach einem der Ansprüche 9 bis 10, ferner umfassend das Leiten von verbrennendem Kraftstoff durch einen Steigkanal (94), der zwischen dem Hauptabschnitt (92) und der Vielzahl von Strömungsübertragungskanälen (83) fluidisch verbunden ist, wobei der Steigkanal (94) eine Steigkanalmittelachse (95) aufweist, die sich im Wesentlichen parallel zur Hauptabschnittmittelachse (93) erstreckt.

mungsübertragungskanälen (83) fluidisch verbunden ist, wobei der Steigkanal (94) eine Steigkanalmittelachse (95) aufweist, die sich im Wesentlichen parallel zur Hauptabschnittmittelachse (93) erstreckt.

Revendications

1. Ensemble de chambre de précombustion (60) pour des moteurs à combustion interne (10) fonctionnant au moins partiellement avec un carburant gazeux et ayant un cylindre (14) définissant une chambre de combustion principale (26), l'ensemble de chambre de précombustion (60) s'étendant le long d'un axe central longitudinal (63) et comprenant :

une section supérieure de chambre de précombustion (70) s'étendant le long de l'axe central longitudinal (63), incluant une portion de réception de dispositif d'ignition (66) conçue pour recevoir un dispositif d'ignition (62) et incluant une portion de réception de fourniture de carburant (74) pour la réception d'un dispositif de fourniture de carburant, la portion de réception de fourniture de carburant (74) ayant un axe central (75) s'étendant parallèlement à l'axe central longitudinal (63) avec un décalage prédéterminé (77) ;

une section inférieure de chambre de précombustion (80) s'étendant le long de l'axe central longitudinal (63) et connectée à la section supérieure de chambre de précombustion (70), la section inférieure de chambre de précombustion (80) incluant une pluralité de passages de transfert de flux (83) ;

une chambre de précombustion (90) délimitée à l'intérieur de la section supérieure de chambre de précombustion (70) et la section inférieure de chambre de précombustion (80) et connectable fluidiquement à la chambre de combustion principale (26) par l'intermédiaire de la pluralité de passages de transfert de flux (83), la chambre de précombustion (90) incluant une portion principale (92) ayant un axe central de portion principale (93) s'étendant parallèlement à l'axe central longitudinal (63) avec un décalage prédéterminé (91) ; et

un dispositif d'ignition (62) monté sur la portion de réception de dispositif d'ignition (66) et conçu pour initier un événement de combustion au niveau d'un point d'ignition (99) à l'intérieur de la portion principale (92), **caractérisé en ce que** le point d'ignition (99) se trouve sensiblement sur l'axe central de portion principale (93).

2. Ensemble de chambre de précombustion (60) selon la revendication 1, dans lequel le dispositif d'ignition

- est une bougie d'allumage (62) pour la génération d'une étincelle au niveau du point d'ignition (99), la bougie d'allumage (62) ayant un axe central de bougie d'allumage (67) s'étendant parallèlement à l'axe central longitudinal (63) avec le décalage prédéterminé (91).
- 5
3. Ensemble de chambre de précombustion (60) selon l'une quelconque des revendications précédentes, dans lequel le dispositif d'ignition (62) inclut un axe central de dispositif d'ignition (67) s'étendant coaxialement par rapport à l'axe central de portion principale (93).
- 10
4. Ensemble de chambre de précombustion (60) selon l'une quelconque des revendications précédentes, dans lequel la chambre de précombustion (90) inclut en outre un passage ascendant (94) interconnecté fluidiquement entre la portion principale (92) et la pluralité de passages de transfert de flux (83), le passage ascendant (94) ayant un axe central de passage ascendant (95) s'étendant parallèlement à l'axe central de portion principale (93) avec le décalage prédéterminé (91).
- 15
5. Ensemble de chambre de précombustion (60) selon la revendication 4, dans lequel l'axe central de passage ascendant (95) s'étend coaxialement par rapport à l'axe central longitudinal (63).
- 20
6. Ensemble de chambre de précombustion (60) selon l'une quelconque des revendications précédentes, comprenant en outre une soupape de carburant gazeux montée sur la portion de réception de fourniture de carburant (74) le long de l'axe central de portion de réception de fourniture de carburant (75).
- 25
7. Ensemble de chambre de précombustion (60) selon la revendication 6, dans lequel la soupape de carburant gazeux est conçue pour fournir une quantité prédéterminée de carburant gazeux à la portion principale (92) par l'intermédiaire d'un canal de fourniture de carburant (76) connectant fluidiquement la portion de réception de fourniture de carburant (74) à la portion principale (92).
- 30
8. Moteur à combustion interne (10) fonctionnant au moins partiellement avec un carburant gazeux, le moteur à combustion interne (10) comprenant :
- 35
- un cylindre (14) définissant une chambre de combustion principale (26) ;
- 40
- une culasse (24) délimitant la chambre de combustion principale (26) au niveau d'une extrémité de sommet ; et
- 45
- un ensemble de chambre de précombustion (60) selon l'une quelconque des revendications précédentes, l'ensemble de chambre de pré-
- combustion (60) étant monté sur la culasse (24) et conçu pour initier un événement de combustion principal à l'intérieur de la chambre de combustion principale (26).
- 5
9. Procédé de fonctionnement d'un moteur à combustion interne (10) fonctionnant au moins partiellement avec un carburant gazeux et qui inclut une chambre de combustion principale (26) et un ensemble de chambre de précombustion (60) incluant un axe central longitudinal (63) et une chambre de précombustion (90) avec une portion principale (92) ayant un axe central de portion principale (93) s'étendant sensiblement parallèlement à l'axe central longitudinal (63) avec un décalage prédéterminé (91), la chambre de précombustion (90) étant connectée fluidiquement à la chambre de combustion principale (26) par l'intermédiaire d'une pluralité de passages de transfert de flux (83), le procédé comprenant :
- 10
- la fourniture d'un mélange de combustion dans la portion principale (92) par l'intermédiaire de la pluralité de passages de transfert de flux (83) pendant une course de compression du moteur à combustion interne (10) ;
- 15
- l'ignition du mélange de combustion au niveau d'un point d'ignition (99) à l'intérieur de la portion principale (92),
- 20
- et
- 25
- la fourniture d'une quantité prédéterminée de carburant gazeux dans la portion principale (92) pour l'enrichissement de la portion principale (92) avec du carburant gazeux au moyen d'une portion de réception de fourniture de carburant (74) incluse dans une section supérieure de chambre de précombustion (70) de l'ensemble de chambre de précombustion (60) et conçue pour recevoir un dispositif de fourniture de carburant, la portion de réception de fourniture de carburant (74) ayant un axe central (75) s'étendant parallèlement à l'axe central longitudinal (63) avec un décalage prédéterminé (77), **caractérisé en ce que** le point d'ignition (99) se trouve sur l'axe central de portion principale (93).
- 30
10. Procédé selon la revendication 9, dans lequel l'ignition du mélange de combustion inclut la génération d'une étincelle par une bougie d'allumage (62) ayant un axe central de bougie d'allumage (67) s'étendant coaxialement par rapport à l'axe central de portion principale (93).
- 35
11. Procédé selon l'une quelconque des revendications 9 à 10, comprenant en outre l'acheminement de carburant brûlant à travers un passage ascendant (94) fluidiquement interconnecté entre la portion principale (92) et la pluralité de passages de transfert de
- 40
- 45
- 50
- 55

flux (83), le passage ascendant (94) ayant un axe central de passage ascendant (95) s'étendant sensiblement parallèlement à l'axe central de portion principale (93).

5

10

15

20

25

30

35

40

45

50

55

FIG 1

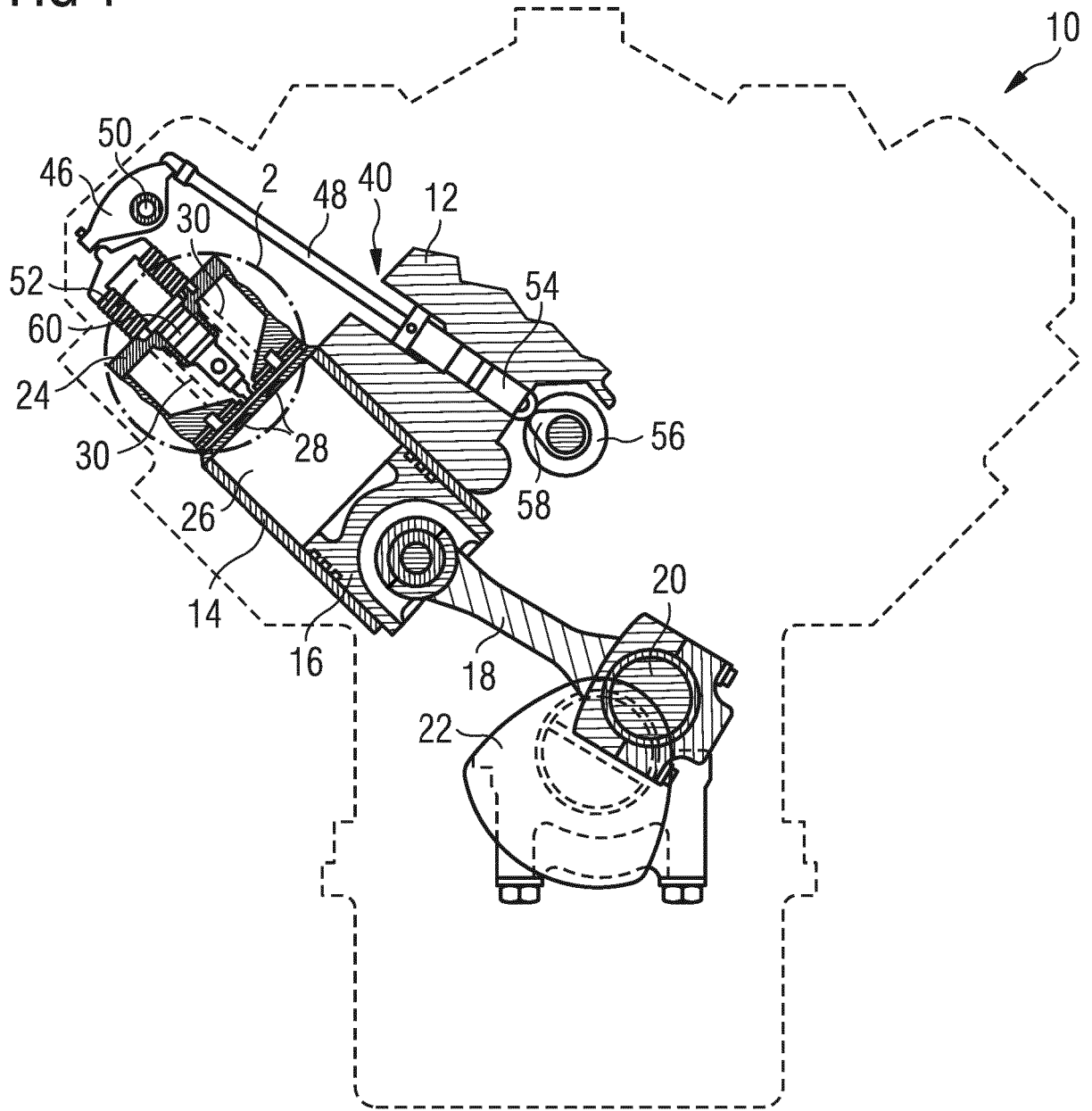

FIG 2

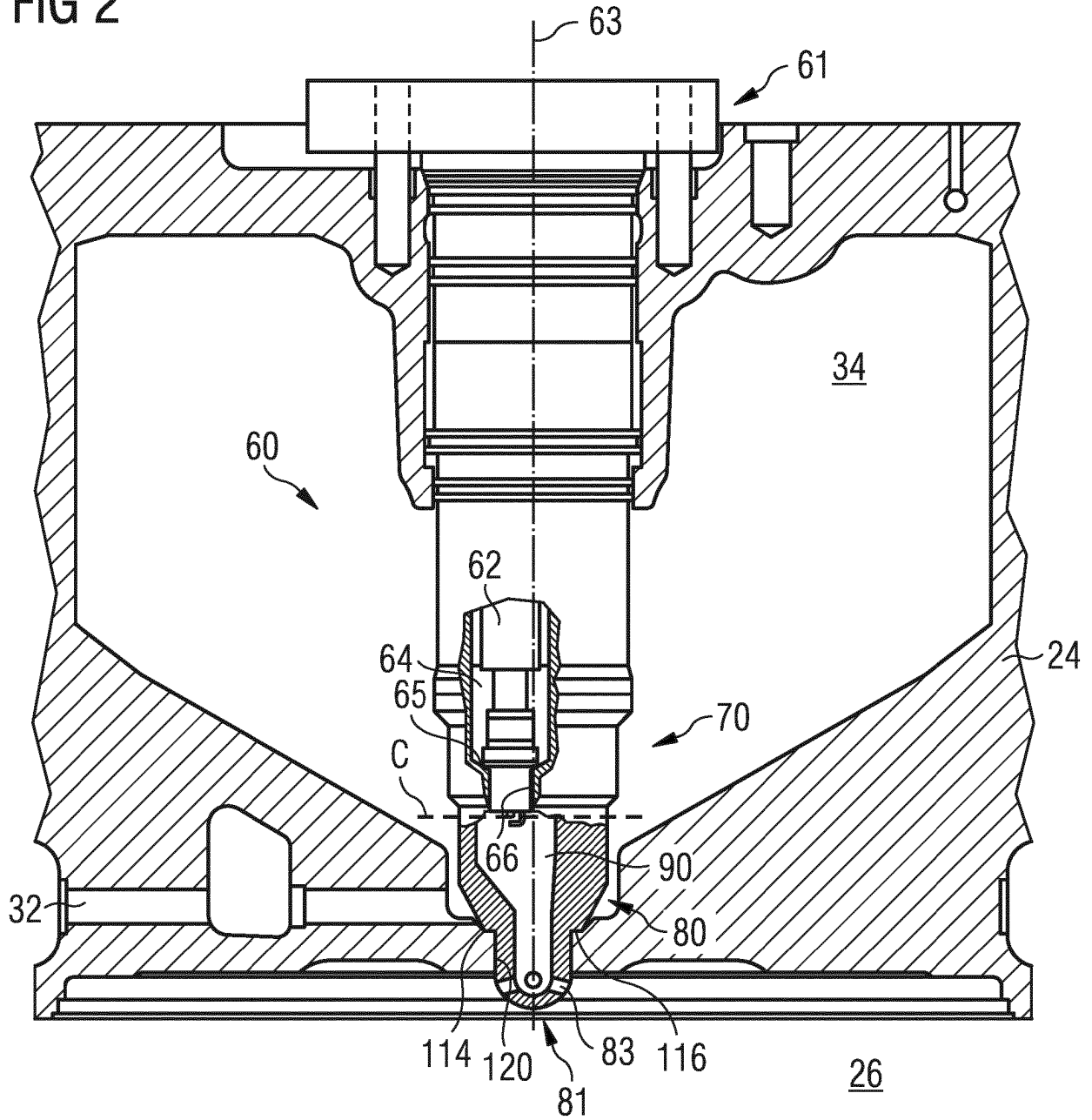

FIG 3

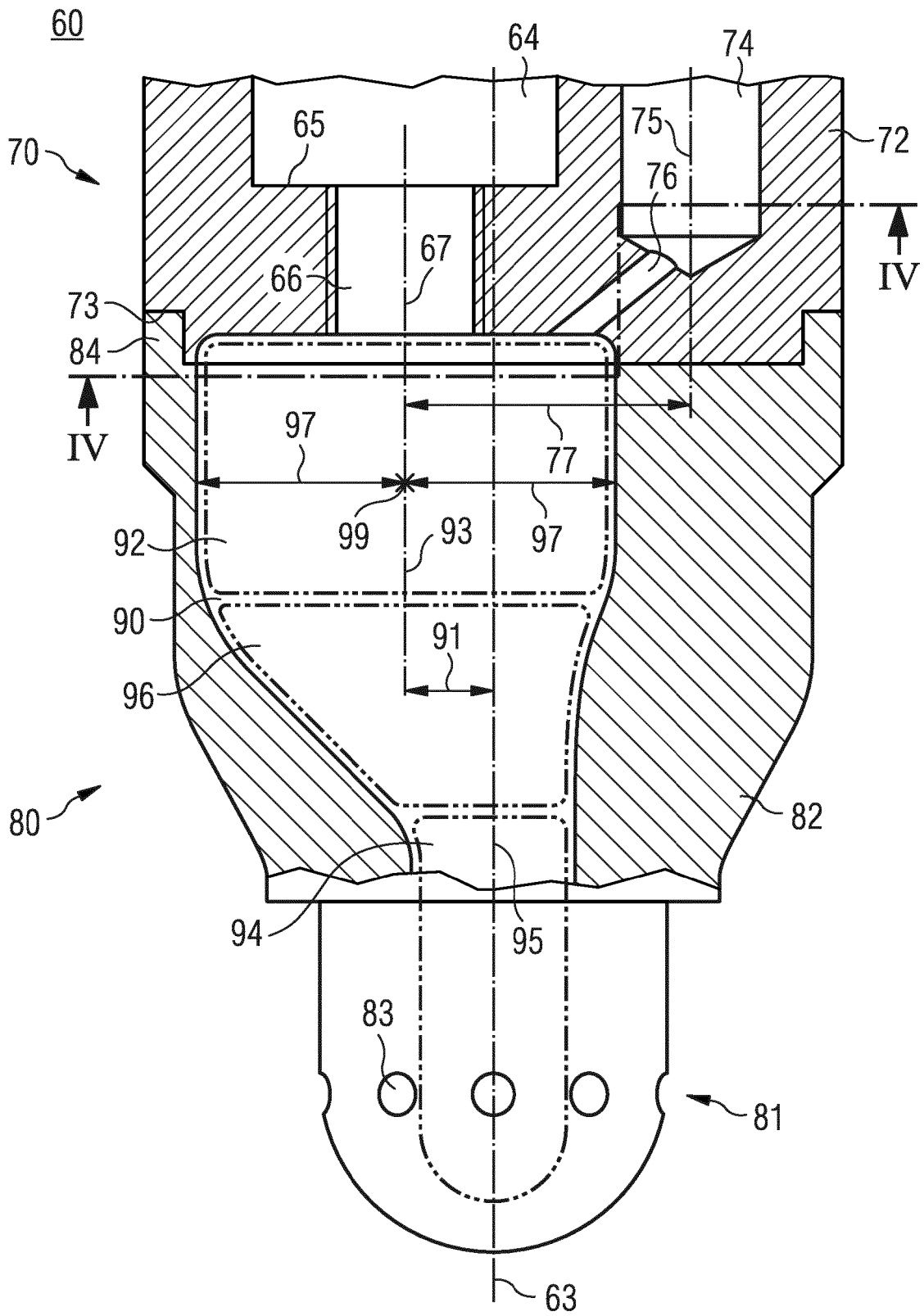
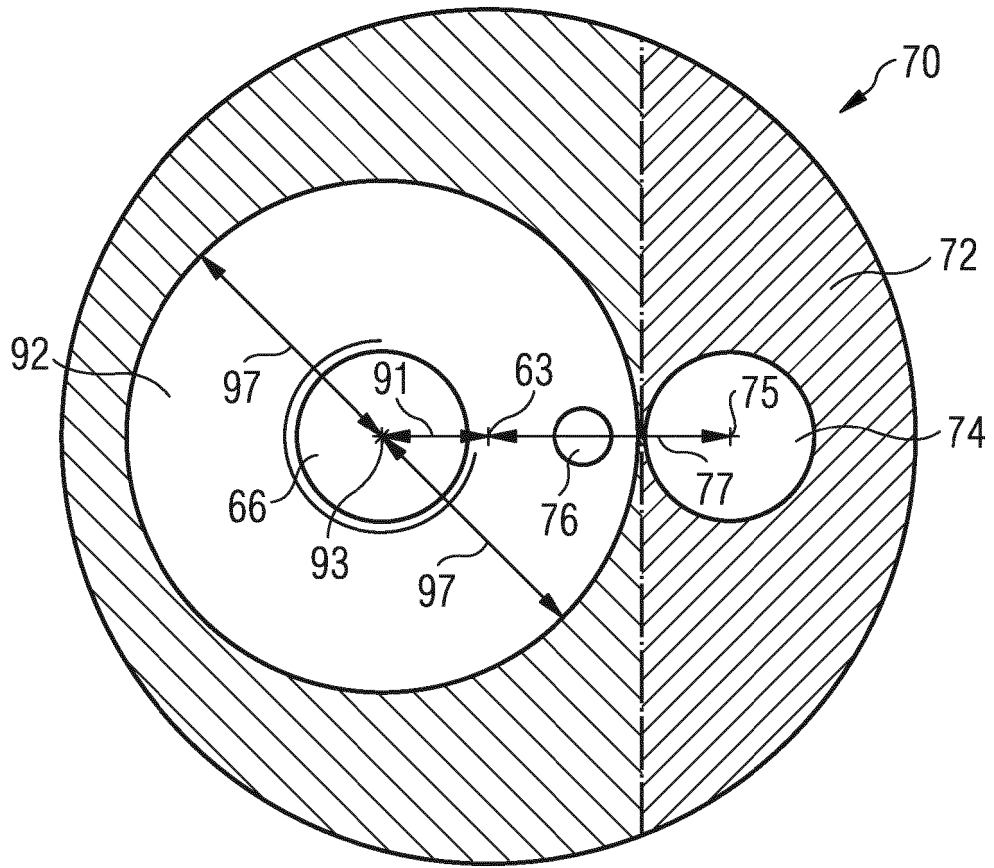

FIG 4



REFERENCES CITED IN THE DESCRIPTION

This list of references cited by the applicant is for the reader's convenience only. It does not form part of the European patent document. Even though great care has been taken in compiling the references, errors or omissions cannot be excluded and the EPO disclaims all liability in this regard.

Patent documents cited in the description

- US 8028674 B2 [0003]
- US 7451727 B2 [0004]
- US 4119065 A [0005]
- US 3970053 A [0005]
- US 6513483 B2 [0005]
- EP 0338882 B1 [0005]
- AT 510435 B1 [0005]
- WO 2009109694 A2 [0005]
- US 3406667 A [0006]
- US 5230313 A [0007]
- EP 2700796 A1 [0008]
- EP 0377265 A [0009]
- WO 2013096979 A [0009]