

July 19, 1927.

1,636,070

A. B. PICKELL  
SPRAYING DEVICE

Filed Aug. 9, 1926

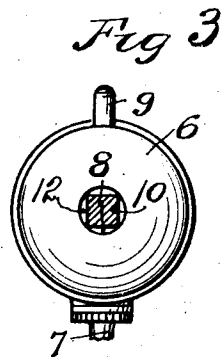
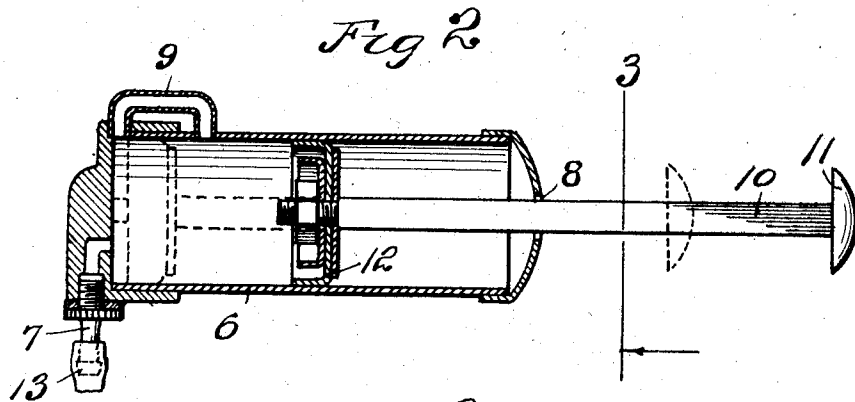
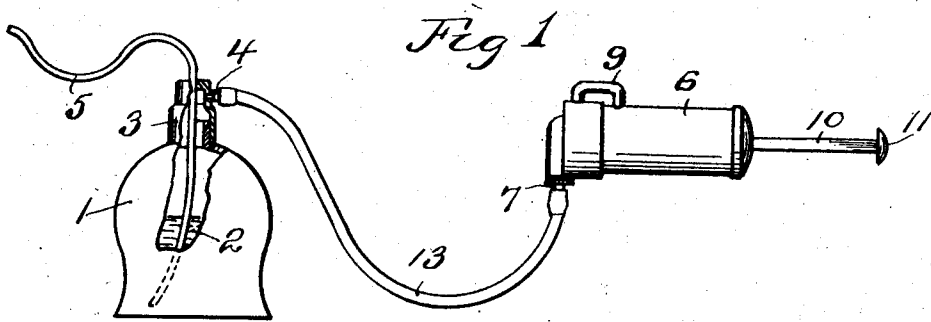

Witness:

*R. Hamilton*

INVENTOR.  
*Archie B. Pickell,*  
BY *Warren P. House,*  
His ATTORNEY.

## UNITED STATES PATENT OFFICE.

ARCHIE B. PICKELL, OF KANSAS CITY, MISSOURI.

## SPRAYING DEVICE.

Application filed August 9, 1926. Serial No. 128,030.

My invention relates to improvements in spraying devices. It is particularly well adapted for use in connection with machines which are used to dispense liquid perfume-  
 5 ery. In some of the machines now in use for this purpose, a hand operated air compressing pump is employed to force air under pressure into a spraying device. In such machines, there is a large amount of  
 10 waste of the liquid perfume due to compressed air being retained in the spraying device after the atomizing operation has been completed.

One of the objects of my invention is to  
 15 provide an air compressing pump of the type referred to, which at the end of the air compressing operation will permit the quick escape of air from the spraying device, thus at once cutting off the air pressure and per-  
 20 mitting the perfume liquid which is still in the discharge pipe of the spraying device to siphon back into the liquid perfume container of the spraying device.

A further object of my invention is to  
 25 provide in the compressing cylinder a by-pass through which the compressed air from the spraying device can escape as soon as the piston reaches the end of its compression stroke.

Still another object of my invention is to  
 30 provide novel means for permitting the escape of compressed air from the spraying device and which is readily applicable to machines now in use.

Another object of my invention is to provide a device of the kind described, which is simple, cheap, durable, not liable to get  
 35 out of order, and which is efficient in operation.

The novel features of my invention are hereinafter fully described and claimed.

In the accompanying drawing, which illustrates the preferred embodiment of my invention, as applied to a liquid spraying  
 45 device,

Fig. 1 is a side elevation, partly broken away of my improved spraying apparatus.

Fig. 2 is an enlarged central longitudinal sectional view of my improved air compressing pump.

Fig. 3 is a cross section on the line 3—3 of Fig. 2.

Similar reference characters designate similar parts in the different views.

55 1 designates the liquid container comprising a bottle adapted to contain liquid per-

fume 2, or such other liquid as it may be desired to atomize. 3 designates the usual cap for the bottle having an air inlet pipe  
 4. Mounted in the cap 3 is a discharge pipe  
 60 5, which may be flexible and which extends into the liquid 2.

My improved air compressing pump comprises a cylinder 6 having at its compression end an air outlet comprising a pipe 7, and at  
 65 its other end having an air inlet 8. The cylinder 6 is provided with an air by-pass consisting preferably of a pipe 9, the ends of which communicate with the interior of the cylinder 6, one end of the by-pass being  
 70 closely adjacent to the compression end of the cylinder, and the other end being spaced therefrom a distance greater than the thickness of the piston head to be operated in the  
 75 cylinder.

A manually operated piston has a piston rod 10 reciprocative in the air inlet 8, the outer end of the rod having a finger hold consisting of a button 11 attached thereto. The inner end of the rod 10 has fastened to  
 80 it an ordinary leather cup piston head 12, which is reciprocative in the cylinder 6 between the air inlet 8 and the compressed air outlet pipe 7. To limit the compression stroke of the piston the rod 10 is arranged to  
 85 contact with the compression end of the cylinder 6. At such position of the piston, the piston head 12 is disposed between the ends of the by-pass pipe 9, as shown in dotted lines in Fig. 2.

A pipe 13 has one end attached to the air inlet pipe 4 of the liquid container 1, the other end of the pipe 13 being attached to the outlet pipe 7.

In the operation of the invention, the  
 95 operator pulls the piston rod 10 outwardly a full stroke, upon which air will pass the compressible piston head 12 to the left thereof, as viewed in Fig. 2. The operator then pushes the piston rod 10 inwardly until the  
 100 inner end of the rod strikes the compression end of the cylinder. The air will be compressed in the cylinder, and will pass therefrom through the outlet pipe 7 and pipe 13  
 105 into the container bottle 1 through the inlet pipe 4 and the cap 3. The air pressure in the container above the liquid 2, will force the latter out of the container through the discharge pipe 5.

As soon as the piston head 12 passes to a  
 110 point between the ends of the by-pass pipe 9, the compressed air in the compression end

of the cylinder 6, pipe 13, and container 1 will pass from the compression end of the cylinder 6 through the by-pass pipe 9 past the piston head 12, and will displace the atmospheric air, which has entered the cylinder at the outer end of the piston, which displaced air will escape from the cylinder through the air inlet 8. The flow, from the discharge pipe 5 will almost instantly cease, and as the pressure in the container lowers to atmospheric, the liquid which is still in the pipe 5 will siphon back into the container 1, thereby avoiding much waste of liquid which would otherwise occur if the pressure in the container 1 were not thus quickly reduced to atmospheric.

Upon the next outward stroke of the piston, the displacing air which is at the outer end of the piston, will pass the latter and will again be compressed upon the next inward stroke of the piston. Thus the compressed air, which becomes charged with perfume vapor, will be used over and over, and there will, consequently, be very small loss of such charged air to the atmosphere, thereby effecting a great saving when high priced perfumed is dispensed.

I do not limit my invention to the structure shown and described, as many modifications, within the scope of the appended claims, may be made without departing from the spirit of my invention.

What I claim is:—

1. In a spraying device of the kind described, the combination with a container adapted to hold liquid and adapted to hold air under pressure above the liquid and having an air inlet, and a discharge pipe extending into the container and adapted to have its inlet end below the level of said liquid, of an air compressing cylinder having an air outlet and provided with a by-pass, a tube communicating with said air inlet and

said air outlet and a piston having a piston head reciprocative in said cylinder and adapted to compress air in said cylinder and to force the compressed air through said air outlet, the ends of said by-pass being disposed in the cylinder at opposite ends respectively of said piston head when the latter is at the limit of its compression stroke.

2. In a spraying device of the kind described, the combination with a container adapted to hold liquid and to hold air under pressure above said liquid and having an air inlet, and a discharge pipe extending into said container to a point adapted to be below the level of said liquid, of an air compressing cylinder having a compressed air outlet and having a by-pass the ends of which are located at different distances from the compression end of the cylinder, a pipe communicating with said air outlet and said air inlet, and a piston having a piston head reciprocative in said cylinder and adapted to force compressed air through said outlet, the ends of said by-pass being disposed in the cylinder at opposite ends respectively of said piston head when the latter is at the limit of its compression stroke.

3. In a device of the kind described, the combination with a compressed air container and having an air inlet, of a cylinder having a compressed air outlet adjacent to its compression end and having an air by-pass, a pipe communicating with said air inlet and said air outlet, and a piston having a piston head reciprocative in said cylinder and adapted to compress and force air through said outlet, the ends of said by-pass being disposed in the cylinder at opposite ends respectively of said piston head when the latter is at the limit of its compression stroke.

In testimony whereof I have signed my name to this specification.

ARCHIE B. PICKELL.