

March 7, 1939.

W. R. CORSWIRT

2,149,254

CONSTRUCTIONAL FIGURE

Original Filed Dec. 12, 1934 5 Sheets-Sheet 1

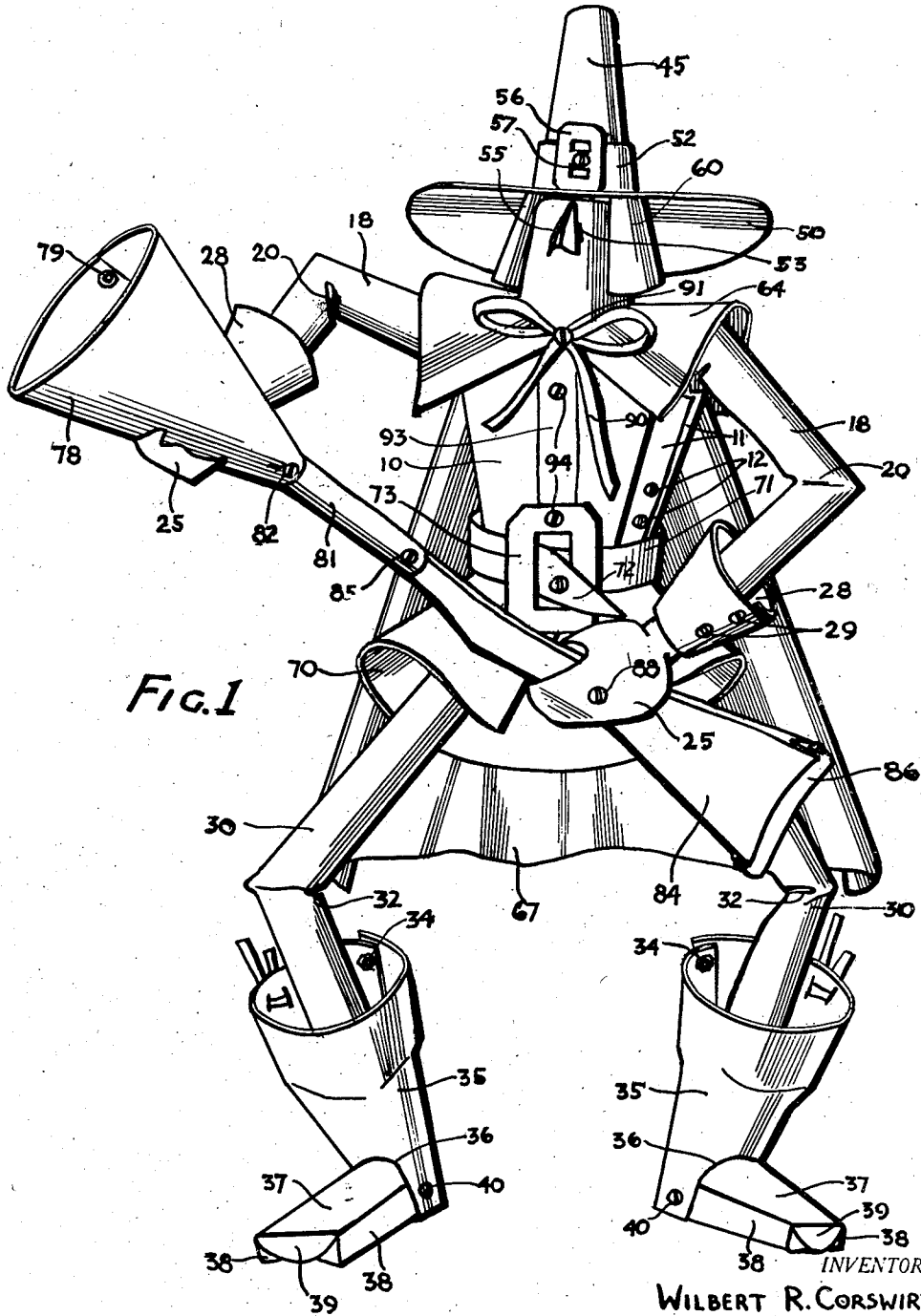

Fig. 1

INVENTOR.
WILBERT R. CORSWIRT
BY
Bohleber & Ledbetter
ATTORNEYS

March 7, 1939.

W. R. CORSWIRT

2,149,254

CONSTRUCTIONAL FIGURE

Original Filed Dec. 12, 1934

5 Sheets-Sheet 2

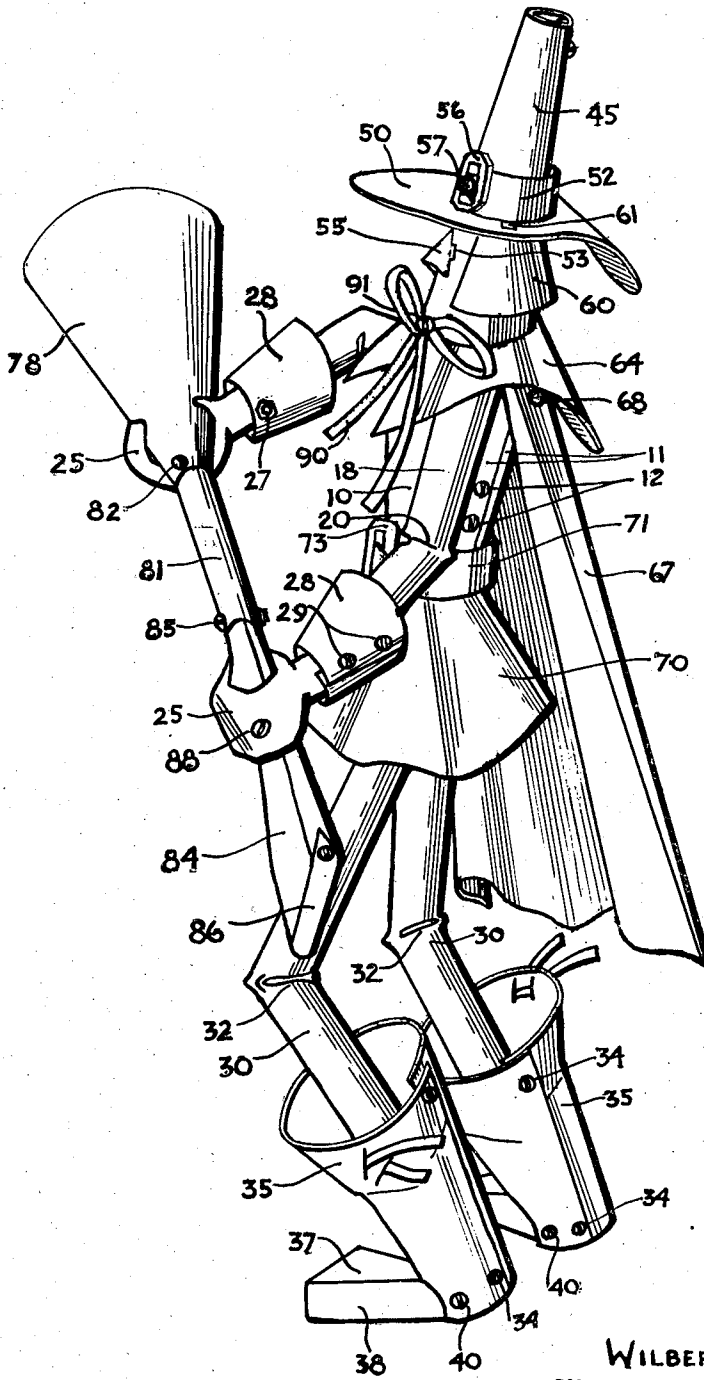

FIG. 2

INVENTOR.

WILBERT R. CORSWIRT

BY

Bohler & Ledbetter
ATTORNEYS

March 7, 1939.

W. R. CORSWIRT

2,149,254

CONSTRUCTIONAL FIGURE

Original Filed Dec. 12, 1934

5 Sheets-Sheet 3

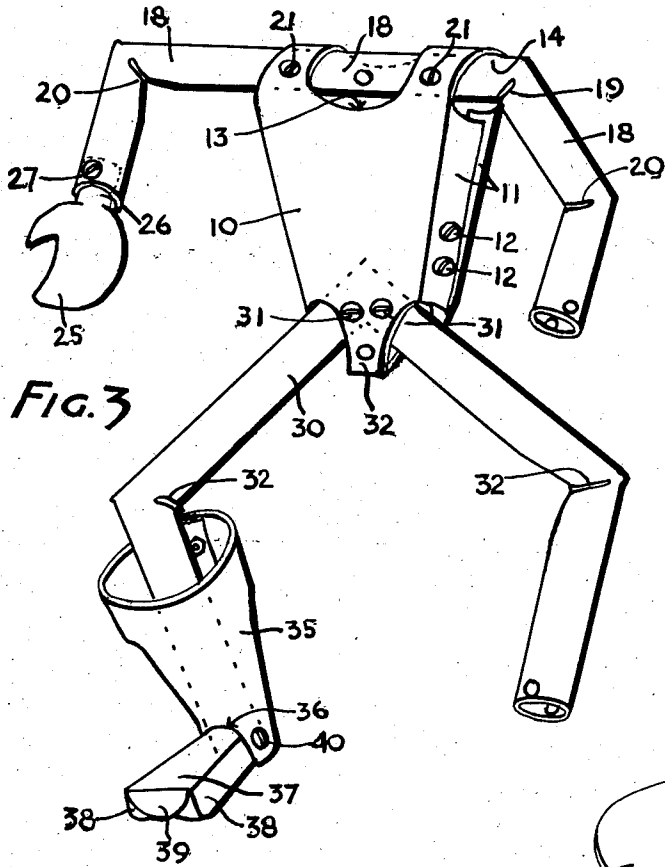

FIG. 3

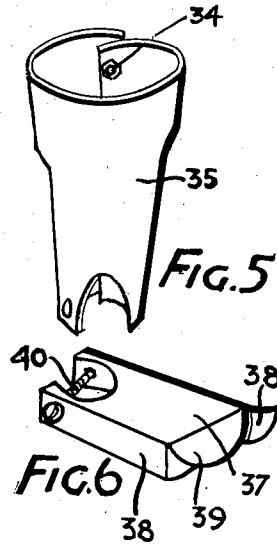

FIG. 5

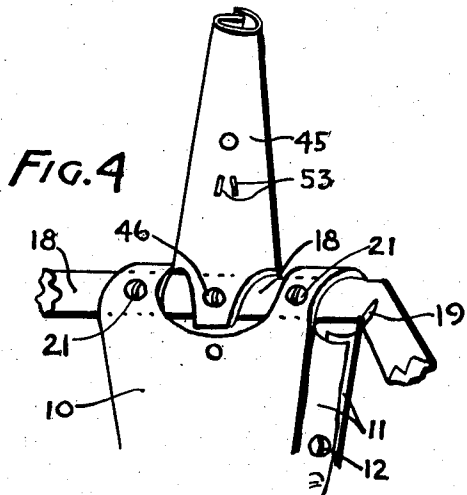

FIG. 4

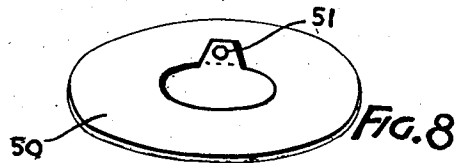

FIG. 8

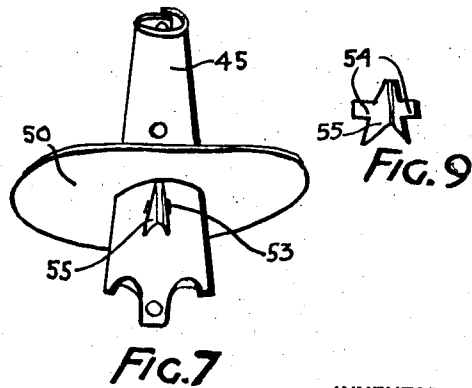

FIG. 7

INVENTOR.

WILBERT R. CORSWIRT

BY

Bohleber + Ledbetter
ATTORNEYS

March 7, 1939.

W. R. CORSWIRT

2,149,254

CONSTRUCTIONAL FIGURE

Original Filed Dec. 12, 1934 5 Sheets-Sheet 4

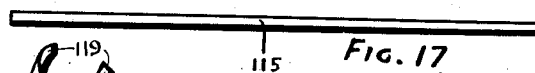
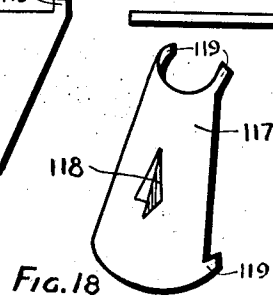
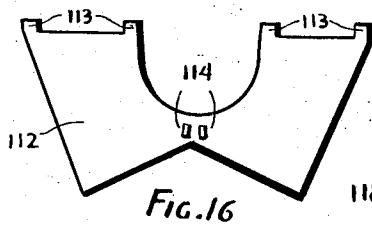
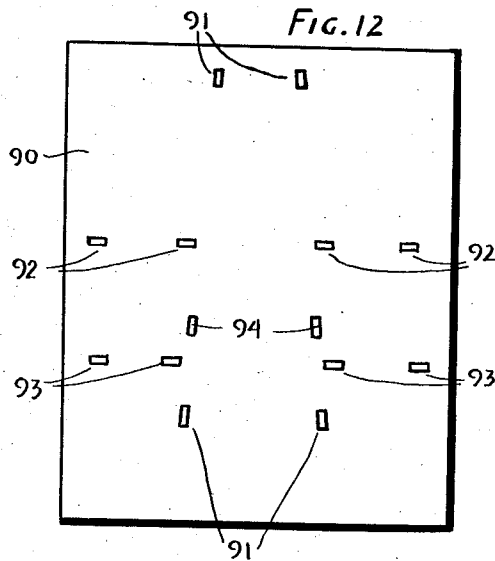
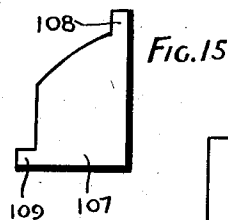
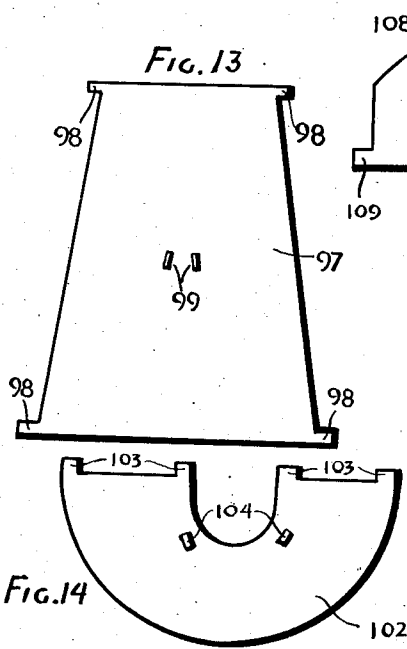
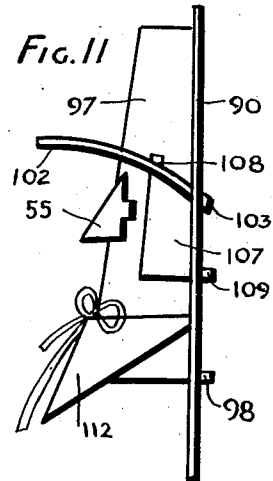
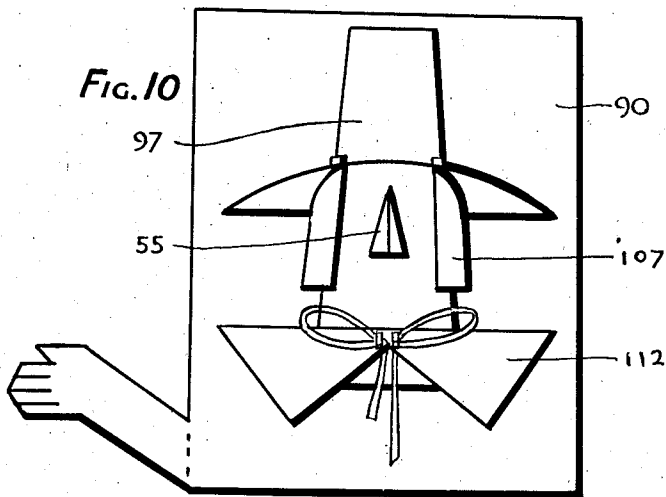

INVENTOR.

WILBERT R. CORSWIRT

BY

Bohler & Leebetter
ATTORNEYS

March 7, 1939.

W. R. CORSWIRT

2,149,254

CONSTRUCTIONAL FIGURE

Original Filed Dec. 12, 1934 5 Sheets-Sheet 5

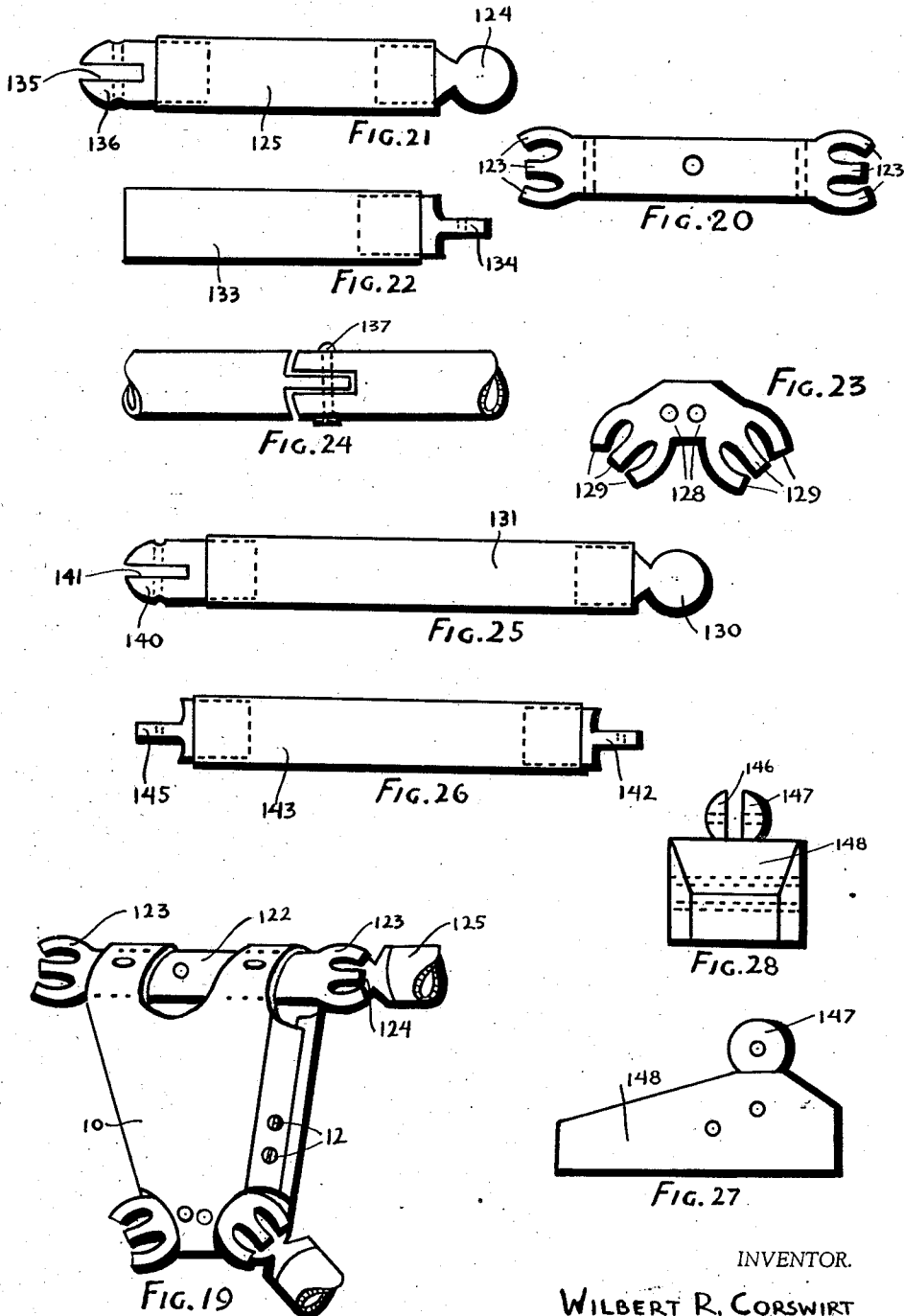

INVENTOR.

WILBERT R. CORSWIRT

BY

Bohler & Ledbetter
ATTORNEYS

UNITED STATES PATENT OFFICE

2,149,254

CONSTRUCTIONAL FIGURE

Wilbert R. Corswirt, New York, N. Y.

Application December 12, 1934, Serial No. 757,145

Renewed August 3, 1938

12 Claims. (Cl. 46—157)

The invention relates to a constructional figure having value as a work of art, but primarily intended as a toy for older children. The child is given instructions for cutting the patterns from a sheet of metal which is thereafter bent to form a particular portion of a figure. The patterns or blanks may be already prepared for the child, if desired, in which case the child bends the patterns into the shape or form of the parts of the figure for which they are intended and assembles the formed patterns or parts together to create the figure. Although there is shown and described specifically herein a human figure, the constructional toy is equally adaptable for constructing figures of animals. I have produced other figures of human as well as animal forms by utilizing the construction disclosed herein which has been particularly applied in producing a stern Puritan as an illustration of the capabilities of the method of constructing figures and of the figures which can be constructed.

It is an object of the invention to construct a figure of sheet metal, or other material having the non-resilient characteristics of sheet metal, in which the various parts of the figure are cut from a sheet in accordance with a prepared pattern and then bent into the desired shape or form of the part of the figure desired. These shapes are then assembled and secured together to complete the figure desired.

Another object is to construct a figure made up of patterns cut from sheet metal and bent into the form of the desired parts of the figure and in which parts there are overlapping portions through which holes are pierced for receiving an inserted securing means to hold the parts together.

Another object of the invention is to construct the arms and legs of the figure from tubular metallic members which may then be bent at a point intermediate their ends to form a bent knee in the case of a leg, or a bent elbow in the case of an arm, thereby giving action to the appearance of the constructed human figure.

Another object of the invention is to construct the head and the crown of a hat of one tubular member. The brim of the hat may then be inserted upon this tubular member to separate the head and the crown of the hat into their respective parts even though formed of a single tubular member.

Other objects will be more apparent from the following description, taken in connection with the accompanying drawings showing one embodiment of the invention, in which:

Figure 1 is a front view of the figure of a Puritan assembled together from parts cut into the desired shape from sheet metal and then bent to form the part of the figure desired, the various parts being assembled and secured together.

Figure 2 is a side view of the Puritan figure shown in Figure 1.

Figure 3 is a view showing the body portion of the Puritan figure with a single tubular member projected through the arm holes in the sides thereof to form the two arms of the figure. The tubular leg members are also shown as they are attached to the body portion. The securing of a boot to one leg is also shown in this figure.

Figure 4 shows the tubular head part forming both a head and a crown of a hat and shows the manner in which this part may be secured to the tubular arm part.

Figure 5 shows in detail the manner in which the upper portion of the boot is constructed and bent.

Figure 6 shows in detail the foot portion of the boot and the screw which secures the foot portion and the upper portion of the boot together and to the leg.

Figure 7 illustrates the tubular head part which forms the head of the figure and the crown of the hat, as shown in Figure 4, with the hat brim and a nose in position thereon.

Figure 8 is a view of the brim of the hat which is slipped over the tubular head part to both separate the head and the hat and to complete the hat with a brim.

Figure 9 is the nose of the figure.

Figure 10 is an assembled view of a different form of the invention in which half or substantially half of a figure is shown mounted upon a supporting backing board to which the various parts of the figure are secured.

Figure 11 is a side view of the figure shown in Figure 10 and shows how the bent sheet material projects from the backing board to form a half figure.

Figure 12 is a plan view of the backing board having slots or perforations therethrough.

Figure 13 is a plan view of the blank of sheet material which is bent to form the head and crown of the hat of the figure upon the backing board.

Figure 14 is a plan view of the blank of sheet material which forms the hat brim.

Figure 15 is a plan view of a wig, two of which are provided.

Figure 16 is a plan view of the blank for forming the collar.

Figure 17 shows the strip from which the tie is made, two such strips forming a complete tie, although one long strip may be used.

Figure 18 shows a view of another form of head and crown of a hat blank in which the nose, instead of being a separate member, is cut from the blank for the head and crown of the hat.

Figure 19 is a partial assembly view of a body of another form of the invention showing a figure in which the arms and legs are pivotally connected thereto.

Figure 20 shows the shoulder bar with prongs or fingers on either end to pivotally grip an arm member.

Figure 21 shows an upper arm member with a ball at one end and a flattened portion at the other.

Figure 22 shows a lower arm member with a flattened member at one end thereof.

Figure 23 is a view of the hip joint member or bar which also has prongs or fingers on either end in order to pivotally receive a leg member.

Figure 24 shows a knee and elbow joint assembled together.

Figure 25 shows an upper leg member with a ball at one end and a slot at the other end.

Figure 26 shows a lower leg member with a flattened portion or member at each end thereof.

Figure 27 shows a shoe made of solid material and preferably of metal.

Figure 28 is a front view of the shoe.

Details and particularly the flat patterns of all of the parts of the figure have not been shown since these parts are simple and it is believed that their shape and construction is clear from the complete figure shown in Figures 1 and 2.

The figure to be described herein is that of a Puritan. This figure is merely illustrative of one of a great many figures which may be constructed utilizing the constructions to be described herein or modifications thereof which are apparent. Figures have been constructed other than those of the human figure and these are constructed in essentially the same manner as the figure to be particularly described herein.

One of the important features of the invention is the use of sheet metal which is relatively non-resilient and consequently any form or shape into which the parts may be bent is retained by the metal. It is for this reason that a figure constructed of sheet metal, or material having similar characteristics in that it is relatively rigid and hence self-supporting, may be given a good deal of character which is not possible with other materials. Figures formed of paper must necessarily be relatively crude or of simple forms, since paper has such resiliency that it will not stay put in the form in which it is bent when the forms have a plurality of folds. This is well illustrated in the cape of the figure shown herein, in which the folds of a cape can be simulated very closely by bending folds into the metal. If a cape were attempted to be made out of paper, the paper would refuse to retain the folds and, consequently, the cape would not have the draped effect of a cloth cape, but which draped effect can be very closely simulated with the non-resilient metal. Most of the patterns are bent into three dimensional parts in that the overall form of the bent pattern occupies a three dimensional space.

Varying thicknesses of sheet metal may be used, although sheet metal of relatively thin gauge, such as eight thousandths of an inch (.008), has been found very satisfactory. The primary considerations in determining the gauge

thickness of the metal is the ease with which the metal can be bent and whether the part to be formed, such as the legs, serves as a support. Heavier gauge metal is preferable, therefore, for the legs, yet the metal must be capable of being bent without any excessive exertion. Copper, aluminum and tin have been used, but the tin is less satisfactory because the edges of the cut patterns or blanks will cut the fingers. Copper and aluminum will not cut the fingers.

The leg and arm members may be bent into tubular form from sheet metal and figures have been made in which the legs and the arms have been so constructed. It has been found, however, that manufactured tubular members of thin metal may be bent as desired to form the legs and arms of the figures in the same manner that the formed tubular members are made into leg and arm parts. Preferably tubing of slightly heavier gauge than that specified above is desirable because a leg may be and usually is bent and the thicker metal will provide sufficient support for the figure, whereas in the case of thinner metal for the leg members, bracing may have to be resorted to at the bent knee because the bending of the tubular leg member tends to weaken the leg at this point.

Leg members of ten thousandths of an inch (.010) aluminum tubing have been found very satisfactory for the legs. The gauge of the tubing of course depends primarily upon the size of the figure. The gauge specified has been found quite satisfactory for a figure having a height in the neighborhood of fifteen inches.

The Puritan shown in Figure 1 has a body part which is cut from sheet metal to form a pattern and then bent through the center to form the chest and back of the body part or the fundamental shape of the body without any detail characteristics. The sides of the body part of both the chest and the back are folded together and secured by means of one or more inserted securing means or screws. An opening is provided at the top of the body portion to receive a head part. The pattern for the body portion is cut so that when the edges are folded together, an arm hole is provided on both sides of the body part as shown.

A single tubular member is projected through the two arm openings. This tubular arm member may be bent at least at one point to simulate the arms of a figure. The tubular member is bent at the shoulder to bring the left arm down towards the side of the figure and is bent intermediate the ends of the arm to form a bent elbow. The other arm projects directly outwardly from the body part and is also bent at the elbow to form a bent arm. The tubular arm member is secured to the body part by perforating adjacent parts of each part and using inserted securing means such as the bolts extending through the shoulders of the body part and through the tubular member. The arms may be formed of two or separate tubular parts, if desired, which may be secured at the shoulders by the bolts. The single tubular arm member as shown, however, is simpler and preferable.

A hand or glove is formed by cutting a hand part or pattern approximating the general shape of a hand or glove. A tubular wrist member is bent at the end of the hand, which wrist member is preferably inserted within the end of the tubular arm member and secured in position by a screw or bolt. A gauntlet

may be formed by forming a conical member, the overlapping edges being secured together by the securing means 29 and secured to the arm by the bolt 27.

5 A single tubular leg member 30 may also be utilized, although the legs may be separate members if desired. The tubular leg member 30 is inserted in the open lower end of the body part 10 and secured in place by the bolts 31. The
10 body part 10 may have a projection 32 extending downwardly therefrom which may also receive a bolt to more securely clamp the leg member 30 to the body part 10. The leg may be bent at the knee 32 to simulate a bent leg. This bend of
15 course is intermediate the ends of the leg, determined by the lower end of one leg of the tubular member 30 and the point of its connection with the body part 10.

20 The boot 35 is formed in two parts, the leg portion being from sheet metal cut and bent into a general conical shape and the overlapping edges being secured together by the securing means 34. The leg portion of the boot 35 is then slipped onto the lower portion of the leg 30 of the figure. There is a cut out 36 on one side of
25 the leg portion of the boot 35 to receive the foot portion 37. The foot portion 37 is a box-like structure and formed by bending the sides 38 and the front 39 downwardly and underneath to simulate the foot portion of the boot. The foot portion
30 37 and the leg portion 35 of the boot are secured to the leg by a bolt 40 which extends through the three parts as shown in Figure 3.

35 The head and crown of the hat of the figure are formed of a tubular member 45 which is preferably conical. The tubular member is generally or approximately the foundational shape of a head without characteristic details, such as a nose, and other characteristic parts of the head
40 are added to form such protruding characteristic parts. This head part is secured to the tubular arm member 18 by an inserted securing means such as a screw or bolt 46 passing through both of these parts.

45 The brim of the hat 50 is an accouterment of the head and is nothing more than a disk with a hole therein which fits over the conical head part 45. A tab 51 may be provided on the hat
50 brim 50 to secure the hat in position upon the head part 45. A hat band 52 with a buckle 56 may finish the hat, the screw 57 holding these parts on the head part 45.

The head part preferably carries a pair of slots 53 to receive cooperating supporting tabs 54 upon a nose member 55. The nose member is bent into the general shape of a nose and the tabs 54 are inserted in the slots 53 to secure it
55 in place on the head part 45.

60 The wig 60 is formed from a rectangular shaped sheet metal piece having a tab 61 which may be inserted between the hat brim 50 and the head part 45 and then bent downwardly upon the brim to retain the wig in place. This wig is bent circularly and so as to be spaced slightly
65 from the head part 41. The collar 64 is a circular disk having a hole therein and then severed or a segment is cut therefrom at one point so that it may be wrapped around the head part 45 and then bent downwardly both front and back to
70 form a portion extending over the shoulders. This collar not only forms a part of the attire of the figure, but also conceals the securing means, such as the bolts or screws 21 which secure the various parts together. The cape 67 is cut from
75 sheet metal in the form of a frustrated cone and

5 folds are bent into the metal to simulate the draped folds of a cloth cape. The cape is secured underneath the collar 64 and to the shoulders of the body part 10 by means of the screw or bolt 68.

6 The skirt 70 is cut from the sheet metal in a disk pattern with a segment thereof cut out similarly to the collar 64 and bent so that it will wrap around the waist of the figure or the lower part of the body portion 10. The skirt 70 may
10 also have folds to simulate the folds in the skirt of a cloth coat. The belt 71 is a sheet metal ribbon wrapped around the figure to conceal the point of juncture between the skirt 70 and the body part 10. The belt 71 may have a point 72
15 which is projected through the opening of a metallic buckle 73 to simulate the well known Puritan buckle and belt.

20 The gun or blunderbuss is formed in four-pieces. The conical muzzle 78 is bent into a conical form and secured in this form by securing means 79. The cylindrical barrel 81 of the gun is then secured to the conical muzzle 78 by a bolt 82. The barrel 81 is a tubular member bent from sheet metal or a manufactured metallic
25 tube. The stock 84 is also bent from sheet metal into the form shown and secured to the barrel 81 by a securing means 85. A shoulder plate 86 may be inserted over the end of the stock 84. The arms of the Puritan are bent so
30 that the musket or blunderbuss is held before the Puritan with one hand 25 being wrapped underneath the muzzle of the gun and the other hand 25 being wrapped around the stock of the gun. A screw 88 passing through the hand 25 and the
35 stock 84 of the gun may secure these two parts together and a similar securing means is used for the other hand at the muzzle 78 of the gun.

40 The string tie 90 is a metallic ribbon bent into the form of a bow and secured in position at the neck of the figure by a securing screw 91. The body part 10 may simulate the jacket of a coat by extending a metallic band 93 from the bow 90 to the buckle 73. The band 93 may be secured
45 in place by screws 94.

50 In the construction shown in Figures 10 through 18 a backing or backing board 90 is provided. This backing board is provided with slots 91, 92, 93 and 94 therethrough. A head and crown of a hat member 97, shown in Figure 13, is
55 approximately half the size of the head and crown of a hat member shown in Figures 4 and 7, since this member forms only half of this part of the figure and hence needs to be bent through a half circle only. The member 97 has projections or projecting tabs 98 along the outer edges
60 thereof which are received into the slots 91 in the backing board 90, after which they are bent to secure this head and crown of a hat member to the backing board. Any other method of securing these parts to the backing board is contemplated. The member 97 may also be provided with slots 99 therethrough to receive the nose
65 shown in Figure 9 and secure the same upon the head and crown of hat member 97.

70 The hat brim 102 is also only half of the brim member shown in Figure 8, since it is to be a projecting hat brim for the hat of a figure as shown in Figures 10 and 11. The hat brim is also provided with tabs 103 which are received
75 in the slots 92 of the backing board 90. The hat brim member has a pair of slots 104 each of which receives a tab upon a wig shown in Figure 15.

The wig 107 has an upwardly projecting tab 108 and a sidewardly projecting tab 109, the tab

108 being received in one of the slots 104 in the hat brim 102, and the tab 109 projecting through one of the slots 94 in the backing board 90. These tabs are also bent to secure the wig in position.

5 Figure 16 shows a collar pattern 112, prior to bending, having tabs 113 projecting therefrom which are received into the slots 93 in the backing board 90. The collar has a bar of closely positioned slots 114 to receive the tie 115 shown in Figure 17. One or two of these tie pieces may be provided, depending upon how long a tie is desired.

10 Figure 18 shows the crown of a hat and head member 117 which is similar to that shown in Figure 13, excepting that instead of providing a separate nose piece, two sides of a triangular section are cut from the head and crown of a hat member 117. This triangular section is then bent along the third side of the triangular section to form a projecting nose piece 118. The crown of a hat and head member 117 similarly is provided with tabs 119 projecting therefrom which are received in the slots 91 of the backing board 90.

25 Generally the parts shown in Figures 10-18 are of a material having no or substantially no resiliency so that they stay in their bent form. Some part, however, such as the crown of hat and head member 97 is so supported by the backing board 90 that even though it should not stay in bent position because of resiliency in the sheet material, the backing board so supports the member that it retains its bent position when carried by, mounted or secured to the backing board. In this form of the invention then all parts need not be made of non-resilient sheet material, although some parts not so supported necessarily must be formed of relatively non-resilient material in order to retain the desired bent shape or form.

40 Figures 19 through 28 show a figures very similar to that shown in Figures 1 and 2, excepting that ball and socket joints are provided for the shoulders and the hips of the figure. In addition, the elbow and knees are provided with pivoted joints. The body 10 is identical with that shown in Figure 3. A shoulder bar 122, shown particularly in Figure 20, has a plurality of fingers 123 formed on each end of the shoulder member. These fingers 123 receive the ball 124 carried by the upper arm member 125, after which the fingers are bent around the ball to provide a ball and socket joint at the shoulder of the figure.

55 The hip member 128, shown in Figure 23, is similarly provided with fingers 129 which receive the ball 130 on the upper leg member 131, after which the fingers 129 are bent around the ball to provide a ball and socket joint. These ball and socket joints enable the figure to have the arms and legs adjusted to any position at any time.

60 The lower arm member 133 has a flattened portion 134 formed preferably on a separate member secured to the member 133. The flattened portion 134 is received into a slot 135 provided in a slotted member 136. These two parts are secured together by a pin, rivet, or other means 137 passing through holes in overlapping portions of both members so that a pivotal joint is provided which also secures these parts together.

70 The upper leg member also carries a slotted member 140 which has a slot 141, similar to the slot 135 in the slotted member 136 of the upper arm member 125 shown in Figure 21. A flat-

tened member 142 carried by the lower leg member 143 is received therein and riveted together to form a pivotal connection at the knee joint like the connection shown in Figure 24.

5 The other end of the lower leg member 143 also carries a flattened portion 145 which is received in a slot 146 of a slotted projection 147 carried by a shoe member 148. These two parts are secured together with a rivet and provide a pivotal connection between the shoe and the lower leg member 143. The shoe is preferably a solid metallic piece in order to provide a heavy foundation or support for the figure so that it will stand upright.

10 It will be noted that all of the primary bends are straight line bends in that a straight line bending axis is used in which a straight line will lie within the sheet material at the bend. The type of bend may also be described as being in one direction only. Such straight line bends are simple to perform with the fingers, with or without a form to follow, and do not require cold flow of the material, such as in pressed work, by which bends in two directions can be formed in sheet material. Generally animal figures of the prior art having featural characteristics are so formed by using pressing dies or forms which press out the features, such as a nose or ear, from the single sheet and by use of which cold flow of the material results in the pressed out parts. Bends, other than straight line bends, are illustrated in the invention herein in secondary bends, such as illustrated by the bends at elbow joints and knee joints, which bends, however, are made only after the primary straight line bends have been made. In like manner, the shaping of one or more elements as go to make up any one or more featural characteristics illustrated in the invention is done by mere bending and without any die shaping to bring about any flow of metal, although all featural characteristics need not be so formed.

25 Various modifications will occur to those skilled in the art in the configuration, composition and disposition of the component elements going to make up the invention as a whole, as well as in the selective combination or application of the respective elements, and no limitation is intended by the phraseology of the foregoing description or illustrations in the accompanying drawings, except as indicated in the appended claims.

What is claimed is:

1. A constructional figure comprising sheet metal parts to be connected together, the sheet metal parts being formed into desired patterns and bent into desired shapes, the metal sheet being relatively non-resilient so that the sheet metal parts remain in bent position, circular parts to form arms and legs at least one of which is bent at a point intermediate its ends, holes through the overlapping portions of parts to be connected together, and securing means inserted through the holes to secure connected parts together to form a figure.

2. A constructional figure comprising sheet metal parts formed into desired patterns and bent into desired shapes, the metal sheet being relatively non-resilient so that the sheet metal parts remain in bent position, a tubular head part forming the head of the figure and the crown of a hat, holes through the overlapping portions of connected parts, and securing means inserted through the holes to secure connected parts together to form a figure.

3. A constructional figure comprising sheet

metal parts to be connected together, the sheet metal parts being formed into desired patterns and bent into desired shapes, the metal sheet being relatively non-resilient so that the sheet metal parts remain in bent position, tubular members to form arms and legs at least one of which is bent at least once at a point intermediate its ends, a tubular head part forming the head and crown of a hat, holes through the overlapping portions of connected parts, and securing means inserted through the holes to secure connected parts together to form a figure.

4. A constructional figure comprising sheet metal parts to be connected together, the sheet metal parts being formed into desired patterns and bent into desired shapes, the metal sheet being relatively non-resilient so that the sheet metal parts remain in bent position, tubular members to form arms and legs at least one of which is bent at least once at a point intermediate its ends, a tubular head part forming the head and crown of a hat, a hat brim part inserted over the tubular head part, holes through the overlapping portions of connected parts, and securing means inserted through the holes to secure connected parts together to form a figure.

5. A constructional figure comprising sheet metal parts to be connected together, the sheet metal parts being formed into desired patterns and bent into desired shapes, including a body part having arm openings on each side thereof, the metal sheet being relatively non-resilient so that the sheet metal parts remain in bent position, a tubular member to form the legs, a single tubular part forming the arms projected through the arm openings to form the arms, at least one of the tubular members being bent at a point intermediate its ends, holes through the overlapping portions of connected parts, and securing means inserted through the holes to secure connected parts together to form a figure.

6. A constructional figure comprising sheet metal patterns which are bent into desired shapes to form parts of a figure, the metal sheet being relatively non-resilient so that the sheet metal patterns remain in bent position, circular parts to form arms and legs, movable connections between parts of the figure which overlap each other, holes through some of the overlapping portions of connected parts, and securing means inserted through the holes to secure connected parts together to form a figure having at least one movable connection.

7. A constructional figure comprising sheet metal patterns which are bent into desired shapes to form parts of a figure, the metal sheet being relatively non-resilient so that the sheet metal patterns remain in bent position, circular parts to form arms and legs, pivoted connections between certain parts of the figure which overlap each other, ball and socket connections between other connecting parts of the figure which also hold these parts together, holes through overlapping portions of the connected parts other than the ball and socket connections, and securing means inserted through the holes to secure connected parts together to form a connected figure and pivots at the pivoted connections.

8. A constructional figure of the animal family comprising sheet material patterns including a head pattern bent into a three dimensional shape simulating at least part of the fundamental shape of a head, and patterns of other characteristic features of the head bent into forms approximating the shapes of at least some of the char-

acteristic features of the head, the primary bends being formed upon a straight line bending axis, the sheet material having sufficient rigidity so that these bent sheet material patterns remain self-supporting in their bent three dimensional form; and means retaining the bent sheet material pattern parts in proper relation to each other to form at least part of the head of the animal figure with at least some of the characteristic features of the head.

9. A constructional figure of the animal family comprising sheet material patterns including a head pattern bent into a three dimensional shape simulating at least the fundamental shape of a head, and patterns of other characteristic features of the head bent into forms approximating the shapes of at least some of the characteristic features of the head, the primary bends being formed upon a straight line bending axis, the sheet material having sufficient rigidity so that these bent sheet material patterns remain self-supporting in their bent three dimensional form, and means retaining the bent sheet material pattern parts in proper relation to each other to form at least part of the head of the animal figure with at least some of the characteristic features of the head including a backing board to which one or more of the bent patterns are secured.

10. A constructional figure of the animal family comprising sheet material patterns including a head pattern bent into a three dimensional shape simulating at least the fundamental shape of a head, and patterns of other characteristic features of the head bent into three dimensional forms approximating the shapes of at least some of the characteristic features of the head, the primary bends being formed upon a straight line bending axis, the sheet material having sufficient rigidity so that these bent sheet material patterns remain self-supporting in their bent three dimensional form, means retaining the bent sheet material patterns in proper relation to each other to form at least the head of the animal figure with at least some of the characteristic features of the head including a backing board to which one or more of the bent patterns are secured, and projecting parts upon the backing board also forming part of the figure.

11. A constructional figure of the animal family comprising sheet material patterns including an elongated head pattern bent into a three dimensional shape simulating at least part of the fundamental shape of a head and the crown of hat, and patterns of other characteristic features of the head bent into forms approximating the shapes of at least some of the characteristic features of the head, a hat brim pattern positioned between the ends of the elongated head pattern to divide the same into a head and the crown of a hat, the primary bends being formed a straight line bending axis, the sheet material having sufficient rigidity so that these bent sheet material patterns remain self-supporting in their bent three dimensional form; and means retaining the bent sheet material pattern parts in proper relation to each other to form at least part of the head of the animal figure with at least some of the characteristic features of the head.

12. A constructional figure of the human family comprising sheet material patterns including a head pattern bent into a three dimensional shape simulating at least part of the fundamental shape of a head, and patterns of other characteristic features of the head bent into three

dimensional forms approximating the shapes of at least some of the characteristic features of the head, the primary bends being formed upon a straight line bending axis, the sheet material having sufficient rigidity so that these bent sheet material patterns remain self-supporting in their bent three dimensional form; means retaining the bent sheet material pattern parts in proper relation to each other to form at least part of the head of the human figure with at least some of the characteristic features of the head; a body part to which the head is secured; arms and legs formed of tubular members extending from the body part, and ball and socket joints at the shoulders and bottom of the body part for connecting the arms and legs to the body.

WILBERT R. CORSWIRT.