



HU000026085T2

(19) **HU**(11) Lajstromszám: **E 026 085**(13) **T2****MAGYARORSZÁG**  
Szellemi Tulajdon Nemzeti Hivatala**EURÓPAI SZABADALOM**  
**SZÖVEGÉNEK FORDÍTÁSA**(21) Magyar ügyszám: **E 09 702531**(51) Int. Cl.: **B65D 19/22** (2006.01)(22) A bejelentés napja: **2009. 01. 16.****B65D 19/38** (2006.01)**B65D 19/44** (2006.01)(96) Az európai bejelentés bejelentési száma:  
**EP 20090702531**

(86) A nemzetközi (PCT) bejelentési szám:

**PCT/FI 09/050035**(97) Az európai bejelentés közzétételi adatai:  
**EP 2240376 A1** **2009. 07. 23.**

(87) A nemzetközi közzétételi szám:

**WO 09090309**(97) Az európai szabadalom megadásának meghirdetési adatai:  
**EP 2240376 B1** **2015. 10. 07.**(30) Elsőbbségi adatok:  
**20085044** **2008. 01. 18.** **FI**(73) Jogosult(ak):  
**K. Hartwall Oy AB, 01150 Söderkulla (FI)**(72) Feltaláló(k):  
**MOBERG, Carsten, 01150 Söderkulla (FI)**(74) Képvisező:  
**SBGK Szabadalmi Ügyvivői Iroda, Budapest**(54) **Adapter raklap és rakomány kezelésére szolgáló eljárás**

Az európai szabadalom ellen, megadásának az Európai Szabadalmi Közlönyben való meghirdetésétől számított kilenc hónapon belül, felszólalást lehet benyújtani az Európai Szabadalmi Hivatalnál. (Európai Szabadalmi Egyezmény 99. cikk(1))

A fordítást a szabadalmas az 1995. évi XXXIII. törvény 84/H. §-a szerint nyújtotta be. A fordítás tartalmi helyességét a Szellemi Tulajdon Nemzeti Hivatala nem vizsgálta.



(11) **EP 2 240 376 B1**

(12) **EUROPEAN PATENT SPECIFICATION**

(45) Date of publication and mention  
of the grant of the patent:  
**07.10.2015 Bulletin 2015/41**

(51) Int Cl.:  
**B65D 19/22** <sup>(2006.01)</sup> **B65D 19/38** <sup>(2006.01)</sup>  
**B65D 19/44** <sup>(2006.01)</sup>

(21) Application number: **09702531.6**

(86) International application number:  
**PCT/FI2009/050035**

(22) Date of filing: **16.01.2009**

(87) International publication number:  
**WO 2009/090309 (23.07.2009 Gazette 2009/30)**

(54) **ADAPTOR PALLET AND METHOD OF HANDLING CARGO**

ADAPTER-PALETTE UND VERFAHREN ZUR GEPÄCKBEHANDLUNG

PALETTE D'ADAPTATEUR ET PROCEDE DE MANIPULATION DE MARCHANDISES

(84) Designated Contracting States:  
**AT BE BG CH CY CZ DE DK EE ES FI FR GB GR  
HR HU IE IS IT LI LT LU LV MC MK MT NL NO PL  
PT RO SE SI SK TR**

(30) Priority: **18.01.2008 FI 20085044**

(43) Date of publication of application:  
**20.10.2010 Bulletin 2010/42**

(73) Proprietor: **K. Hartwall Oy AB  
01150 Söderkulla (FI)**

(72) Inventor: **MOBERG, Carsten  
01150 Söderkulla (FI)**

(74) Representative: **Seppo Laine Oy  
Itämerenkatu 3 B  
00180 Helsinki (FI)**

(56) References cited:  
**DE-A1- 19 905 669 DE-U1- 20 219 319  
DE-U1-202006 007 202 DE-U1-202006 007 202  
GB-A- 2 416 527**

**EP 2 240 376 B1**

Note: Within nine months of the publication of the mention of the grant of the European patent in the European Patent Bulletin, any person may give notice to the European Patent Office of opposition to that patent, in accordance with the Implementing Regulations. Notice of opposition shall not be deemed to have been filed until the opposition fee has been paid. (Art. 99(1) European Patent Convention).

## Description

### *Field of the invention*

**[0001]** The present invention relates to an adaptor pallet for transporting and storing a plurality of wheeled dollies.

### *Background of the invention*

**[0002]** Goods of relatively small size are typically transported using wheeled dollies, which are usually platforms, which are mounted on wheels or castors. The goods are stored in containers that are prismatic and whose shape fits into the receptive platform. Upon transportation or temporary storage, the boxlike containers are stacked onto a dolly whose wheels enable easy handling by hand. The shape and size of the dollies are usually standardized to conform advantageously to industrial container models.

**[0003]** While the dollies may be moved about by hand, there is also a need to transport a plurality of dollies at once. Such need would occur e.g. when loading or unloading a trailer or a lorry. If a trailer is loaded dolly by dolly, the long duration of the operation consumes valuable docking time not to mention inflicted gratuitous vehicle idle time. Also, when transported individually, the dollies require thorough and tedious trussing up to prevent unintended movement within the load space. To tackle these disadvantages, adaptor pallets have been developed to aggregate a plurality of dollies carrying piles of containers. These adaptor pallets are usually rather flat and include a deck that has an upper support surface to accommodate a plurality of wheeled dollies, gouges to guide the dolly wheels, means for supporting the deck a certain distance above ground, receptive slots to receive the lifting forks of a forklift, an inclined surface to act as a ramp onto the deck and means for securing the dollies into the adaptor pallet. Such pallets have been extensively described in publication GB2416527 DE 20219319 U1 and DE 202006007202 U1.

**[0004]** However, the current adaptor pallets have considerable disadvantages. A major disadvantage is that adaptor pallets on the market are burdensome, tardy and not especially ergonomic to operate. For example, the construction presented in publication GB2416527 introduces a locking mechanism requiring that the operator swivels two ramp members in order to ensure that the dollies are sufficiently stationary during transport.

**[0005]** There are also other types of locking mechanisms. The most progressive ones utilize locking members which, rather than preventing the movement of the wheels, grab hold to the body of the dolly thus preventing its movement relative to the pallet. Until now they too have been inconvenient to operate due to the shortcomings of their locking mechanisms that will not enable effortless loading sequences. The problem in these types of locking mechanisms can be tracked down to the lock-

ing members, which may not be deactivated properly so that the dollies could be loaded on to the pallet. Even with the most favourable adaptor pallets, the operator must release the dolly from each of the previous locking positions when propelling the dolly to its farthest locking position. This is obviously a considerable disadvantage that results in wasted work effort and inconvenience. The discomfort of the operator may be further elevated by locking mechanisms that are difficult to negotiate combined with the load of the heavy dolly. In addition, previous pallet models were unsuitable to be stored stacked on top of each other when empty due to the shortcomings of their locking mechanisms, which would occasionally break from the weight of the other pallets.

**[0006]** It is an object of the present invention to provide an improved product to tackle at least some aforementioned disadvantages by introducing an evolved adapter pallet construction.

### *Summary of the invention*

**[0007]** The invention is based on a new type of locking mechanism that includes fully independent locking members, which may be deactivated with a lever, which may be operated without having to let go of the dolly. Furthermore, the present invention introduces activation means, which may easily be operated by manipulating a two-dimensional regulator by foot.

**[0008]** More specifically, the apparatus according to the invention is characterized by what is stated in the independent claims.

**[0009]** Considerable advantages are gained with the aid of the invention.

**[0010]** The operator is able to load the adaptor pallet without the unsolicited interference of activated locking members. Also, the locking mechanism may be operated by foot leaving both hands available to handle cargo. The opportunity to secure and release the dollies fluently by foot assuages the burdensome task of negotiating intricate fastening ramp members while supporting a heavily loaded dolly. There are improvements to known locking systems as well; the locking members may be deactivated separately by pressing them downward and the lever that manipulates them remains flat and not disruptive when not specifically turned. Furthermore, because of the advanced locking mechanism along with its lever, empty adaptor pallets are now suitable to be stored stacked on top of each other. Since the lever of the adaptor pallet remains in a horizontal position when not specifically pressed down, the pallets are easy to stack without damaging the lever or other parts of the locking system with the forks of a forklift, as would be the case with conventional pallets. If the locking members would not be independently suspended in relation to their axle, the weight of the other pallets would apply pressure to the locking members resulting in damages in the locking members themselves as well as the lever and other parts that are connected to the locking member. Also, it is im-

portant that the lifting points of the pallet remain accessible regardless of the weight on top of the pallet, so that e.g. the lever will not be damaged by for the lifting forks of a forklift. In addition to easy storage, the present pallet type is advantageous due to the ability to conform with known pallet standards. The design of the pallet allows the structure to stay within the usual standardized pallet dimensions, such as EUR-pallets (1200 mm \* 800mm) and industrial pallets (1200 mm \* 1000 mm and 1200 mm \* 1200 mm).

**[0011]** As mentioned, the lever may be operated by foot, which enables the operator to deactivate the locking members and remove his foot from danger zone before rolling out the dollies. This is a significant reformation to occupational safety, because it mitigates the risk of foot and leg injuries. Furthermore, the fully independent locking members, which fasten the dollies to the pallet, may be deactivated independently by pressing them downward. This feature makes the structure flexible to use, since empty dolly positions may be occupied while other locking members are active.

#### *Brief description of the drawings*

**[0012]** Some embodiments of the present invention shall now be described in detail with reference to the accompanying drawings, in which:

Fig. 1 shows an isometric view of an adaptor pallet loaded with four dollies.

Fig. 2 shows an isometric view of an empty adaptor pallet with activated locking members.

Fig. 3 shows an isometric detail view of the locking system of an adaptor pallet.

Fig. 4 shows an isometric detail view of the locking system illustrated in Fig. 3 when the lever is its down-right position.

Fig. 5 shows an isometric detail view of the locking member of an adaptor pallet.

#### *Detailed description of the preferred embodiments*

**[0013]** As illustrated in Fig. 1, according to one embodiment of the present invention, the adaptor pallet 10 is adapted to receive four dollies 20 in two rows, both incorporating two dollies 20. Each dolly 20 includes four wheels 22, which are located underneath its body. Dollies 20 are loaded onto adaptor pallet 10 by propelling them on their wheels 22 by hand.

**[0014]** As illustrated in Fig. 2, adaptor pallet 10 has three load bearing decks 12, the middle one of which is essentially twice as wide as the other two located at the side ends of adaptor pallet 10. Load bearing decks 12 at the side ends of adaptor pallet 10 have vertical edgings

at their outer ends. Each load bearing deck 12 has a gable wall 15, which is advantageously at least half as lofty as wheel 22. Gable walls 15 are located at either end of adaptor pallet 10 leaving the other end open for the loading of dollies 20. This end shall be referred to as the loading side of adaptor pallet 10. However, according to other embodiments of the present invention, both ends of adaptor pallet 10 may also be left open without said gable wall 15 allowing a run-through structure. Load bearing decks 12 have guide rails 11, which extend longitudinally from the loading side to gable wall 15. The distance between the vertical edging at the outer end of load bearing deck 12 and guide rail 11 is at least the width of wheel 22. The load bearing deck 12 in the middle of adaptor pallet 10 has its guide rail 11 in the middle of its upper face so that it is able to accommodate wheels 22 of dolly 20. Furthermore said guide rail 11 is wedge-shaped at the open end of the middle load bearing deck 12 and wide enough to separate the exceeding of the bodies of dollies 20. Generally speaking, the distance between the inner walls 17 is as narrow as possible in order to optimize adaptor pallet 10 for automatic storage facilities and standard handling equipment. On the other hand, lifting points 18 should be wide enough to accommodate as wide a spectrum of handling equipment as possible.

**[0015]** Load bearing decks 12 are separated by lifting points 18, which are elevated from the ground by walls 17. Lifting points 18 essentially as wide as the track of dollies 20, but at least wider than standard sized lifting forks of ordinary forklifts. Walls 17 therefore rise from load bearing decks 12 and are essentially as high as the ground clearance of dollies 20. Walls 17 are equipped with guide bars 21 which are located at the upper end of walls 17 and which are wedge-shaped at their free end. Adjacent walls 17 are connected by torsion bars 19 which add rigidity to the construction and engage with the lifting forks of the forklift. Both lifting points 18 include a lever 14, which is connected to two locking members 16 via an axle 13.

**[0016]** As illustrated in Fig. 5, locking member 16 is suspended in relation to axle 13 with spring 50 to allow elasticity between the two parts. Spring 50 has a coil-like structure with two pins protruding out of the suspending coil. One of the pins is fixed to locking member 16 and the other is fixed to plate 52 connecting torsion bars 19. The suspension is construed so that, locking member 16 may be bent down as it would when rotating axle 13 clockwise. This way, upon loading adaptor pallet 10, locking member 16 is able to conform to the body of dolly 20 with its inclined shape until its slot engages with the corresponding part of dolly 20. The suspension is essential to one embodiment of the present invention, as it enables dolly 20 to be loaded onto the first row adaptor pallet 10 without deactivating locking member 16.

**[0017]** As illustrated in Fig. 3, lever 14 is located between torsion bars 19 at their wedge-shaped end. Lever 14 is adapted to move axle 13, to which locking members

16 are attached. Lever 14 is also adapted to be moved rotationally. The rotational movement, which is from here on referred to as the first degree of freedom of activation means, is clockwise rotation about axle 13, which rotation may extend up to 90 degrees. Activations means in this context refers to the entity that attends to the activation and deactivation of locking member 16, e.g. lever 14, release rod 31 and axle 13. The linear movement, which is from here on referred to as the second degree of freedom of activation means, is movement in the direction of axle 13. It should thus be noted that although the second degree of freedom of activation means is indeed linear, lever 14 is not moved linearly according to this specific embodiment of the present invention.

**[0018]** The locking system further comprises means for deactivating locking member 16 and releasing it to its activated, upright position. Connected to lever 14 via axle 13 is primary sleeve 36, which is fitted with constrainer 38, which is a spring that is wound around axle 13. It is appropriate to note that axle 13 is not continuous; it extends from lever 14 to the second locking member 16, but there is a gap between primary sleeve 36 and secondary sleeve 34. In other words axle 13 is a member of activation means connecting the essentially functional parts. Constrainer 38 has a coil-like structure with two pins, one of which is fixed to wall 17 and the other is fixed to primary sleeve 36 thus constraining it to a preferred position in relation to lever 14. This position remains constant at all times, which means that when rotated, lever 14 is adapted to return to its original position. Primary sleeve 36 is also fitted to axle 13 and it engages with secondary sleeve 34 like a jaw clutch. There is a gap between the coupling edges of primary sleeve 36 and secondary sleeve 34 when locking member is in its activated position. Secondary sleeve 34 further delivers the rotation to locking members 16 through axle 13. Axle 13 is equipped with compression member 32 between secondary sleeve 34 and torsion bar 19. Compression member 32 enables axial elasticity of restraint bar 35 when retracted from primary sleeve 36 by restraint bar 35. Compression member 32 is restrained by restraint bar 35, which is supported by release rod 31. Release rod 31 is fixed between restraint bar 35 and the torsion bar 19 nearest to lever 14. The other end of release rod 31 is connected to release angle 33, whose horizontal portion is above lever 14 and whose vertical portion covers the front end of lever 14. Accordingly, when executing movement in the second degree of freedom of activation means, release angle 33 is actually pushed in delivering the movement to restraint bar 35.

**[0019]** As illustrated in Fig. 4, when lever 14 is rotated to its farthest position, axle 13 has delivered the rotation to locking member 16. Also, the rotation has made primary sleeve 36 and secondary sleeve 34 interact, which together with the tension of compression member 32 has retracted restraint bar 35 thus moving release rod 31 towards the loading side of adaptor pallet 10. Secondary sleeve 34 has revolved clockwise into its locked position

thus imposing its position on axle 13 and locking member 16. Secondary sleeve 34 is adapted to assume a locked position with the aid of a groove, which engages with a corresponding protruding member in restraint bar 35. The locking groove in secondary sleeve 34 is in an angled position when the locking mechanism is in a deactivated position. However, when lever 14 is rotated in its first degree of freedom, the locking groove in secondary sleeve 34 rotates so that it becomes parallel with the protruding member in restraint bar 35. Restraint bar 35 is then pushed against secondary sleeve 34 and the locking system is secured in a deactivated position. When release rod 31 is moved to the front, release angle 33 is retracted away from lever 14.

**[0020]** When lever 14 is released from the farthest position in its first direction of movement, constrainer 38 returns lever 14 to its original, horizontal position. Now locking member 16 is in its horizontal position and release angle 33 remains retracted from lever 14. The gap between the coupling edges of primary sleeve 36 and secondary sleeve 34 is now closed up. Once release angle 33 is pushed in, the movement is delivered to release rod 31, which moves restraint bar 35 and compresses compression member 32. The movement makes secondary sleeve 34 rotate in relation to primary sleeve 36, which allows axle 13 together with locking member 16 to return to their original positions. The locking groove in secondary sleeve 34 has also retracted from the protruding member in restraint bar 35. Locking member 16 is now activated. It is beneficial to note that axle 13 has now performed a restored radial displacement at its point of discontinuity.

**[0021]** In this context, lifting point 18 refers to - rather than a single point - the whole gap between walls 17. Furthermore in this context, the first and second directions of movement of activation means refer to what is described above, but they may naturally be e.g. opposite directions of the same path according to other embodiments of the present invention.

**[0022]** The loading and unloading of adaptor pallet is described in the following.

**[0023]** When adaptor pallet 10 is empty, it is prepared for loading by deactivating locking members 16 between load bearing decks 12 intended for occupation. Deactivation is done by moving lever 14 to its first direction. The motion is delivered directly to locking member 16, which is then set to deactivated position i.e. horizontally. Once locking members 16 are horizontal, first dollies 20 are loaded onto adaptor pallet 10. To prevent dollies 20 from rolling on load bearing decks 12, they are locked into position by activating locking members 16. This is carried out by moving activation means to its second direction by pushing release angle 33 inwards, which releases locking member 16 from its deactivation position and allows its slot to engage with the body of dolly 20, as illustrated in Fig. 1. Once the first dollies 20 are in place, the next ones may be loaded in a similar manner. However, when loading the last dolly 20 of a certain file,

locking member 16 does not have to be deactivated prior rolling dolly 20 onboard. On the contrary, dolly 20 is rolled directly onto adaptor pallet, in which case suspended locking member 16 conforms to the body of dolly 20 with its inclined shape until its slot engages with the corresponding part of dolly 20. Once all dollies 20 are onboard and secured, adaptor pallet 10 is ready for transport. Adaptor pallet 10 is thus ready to be hoisted from lifting points 18 with e.g. the lifting forks of a forklift.

**[0024]** Alternatively, dollies 20 may all be loaded onto adaptor pallet 10 while all locking members 16 are deactivated. This requires that the surface on which adaptor pallet 10 lies is even enough so that dollies 20 do not roll off by themselves. Once all dollies 20 are on board, locking members 16 are activated in a similar fashion as described above. When adaptor pallet 10 is ready for unloading, dollies 20 onboard are released from their locked positions by deactivating locking members 16 as described above. Once they are in their horizontal position, dollies 20 are free to be rolled off adaptor pallet 10.

## Claims

### 1. An adaptor pallet comprising:

- at least one load bearing deck (12) to receive the wheels (22) of a dolly (20), the load bearing decks (12) being separated by at least one lifting point (18) to receive the lifting forks of a forklift; and
- at least one locking member (16) to engage with the dolly (20);
- activation means for manipulating the locking member (16), wherein the activation means comprises at least a lever (14) and wherein said activation means (14) is adapted to deactivate said locking member (16) when rotated and adapted to activate said locking member (16) when moved in a linear direction **characterized in that**
- the lever (14) is adapted to move an axle (13), to which locking members (16) are attached, and **in that**
- connected to said locking member (16) is means for suspending said locking member (16) in relation to its axle (13), wherein a dolly (20) may be loaded albeit said locking member (16) being activated.

2. An adaptor pallet according to claim 1, **characterized in that** said rotational movement is about said axle (13).

3. An adaptor pallet according to claim 1, **characterized in that** said linear movement is in the axial direction of said axle (13).

4. Method of handling cargo by a system comprising at least one dolly (20) and one adaptor pallet (10), which comprises activation means for the activation and deactivation of a locking member (16), which has an axle (13) and means for suspending said locking member (16) in relation to its axle (13), **characterized by:**

- propelling at least one dolly (20) onto the first row of the adaptor pallet (10), wherein a dolly (20) may be loaded albeit said locking member (16) being activated with aid of said means for suspending said locking member (16) in relation to its axle (13) or;
- prior to propelling at least one dolly (20) onto said adaptor pallet (10) deactivating the locking member (16) of the adaptor pallet (10) by rotating the activation means of said adaptor pallet (10) about the axle (13) of said locking member (16), whereby rotating said axle (13), said locking member (16) rotates into its deactivated position; where after propelling at least one dolly (20) onto said adaptor pallet (10); and
- thereafter activating at least one of said locking members (16) by linearly moving the activation means of said adaptor pallet (10) in the direction of said axle (13) of said locking member (16) to secure the cargo.

5. Method of handling cargo according to claim 4, **characterized in that** the last dolly (20) of a file is loaded onto said adaptor pallet (10) without moving said activation means.

6. Method of handling cargo according to claims 4 or 5, **characterized in that** said adaptor pallet (10) is hoisted from its lifting points (18).

7. Method of handling cargo according to claim 4, **characterized in that** said adaptor pallet (10) is prepared for unloading by moving said activation means in a linear direction.

## Patentansprüche

### 1. Adapterpalette umfassend:

- mindestens eine Lastaufnahme­fläche (12) zur Aufnahme der Räder (22) eines Transportwagens (20), wobei die Lastaufnahme­flächen (12) durch mindestens einen He­bepunkt (18) zur Aufnahme der Gabeln eines Gabelstaplers voneinander getrennt sind; und
- mindestens ein Schließorgan (16) zum Eingriff mit dem Transportwagen (20);
- Betätigungsmittel zur Betätigung des Schließorgans (16), wobei die Betätigungsmittel

mindestens einen Hebel (14) umfassen und wobei die Betätigungsmittel (14) zur Deaktivierung des Schließorgans (16) ausgebildet sind, wenn sie verdreht werden, und zur Aktivierung des Schließorgans (16), wenn sie in einer linearen Richtung bewegt werden,

**dadurch gekennzeichnet, dass**

- der Hebel (14) zur Bewegung einer Achse (13) bestimmt ist, an der Schließorgane (16) befestigt sind, und dass  
- an dem Schließorgan (16) ein Mittel zum beweglichen Lagern des Schließorgans (16) an seiner Achse (13) verbunden ist, wodurch ein Transportwagen (20) aufgeladen werden kann, obwohl das Schließorgan (16) aktiviert ist.

2. Adapterpalette nach Anspruch 1, **dadurch gekennzeichnet, dass** die Drehbewegung um die Achse (13) stattfindet.

3. Adapterpalette nach Anspruch 1, **dadurch gekennzeichnet, dass** die lineare Bewegung in Axialrichtung der Achse (13) stattfindet.

4. Verfahren zur Handhabung von Transportgut durch ein System umfassend mindestens einen Transportwagen (20) und eine Adapterpalette (10), die Betätigungsmittel zur Aktivierung und Deaktivierung eines Schließorgans (16) aufweist, welches eine Achse (13) und Mittel zur beweglichen Lagerung des Schließorgans (16) an seiner Achse (13) aufweist, **gekennzeichnet durch:**

- Aufschieben mindestens eines Transportwagens (20) auf die erste Reihe der Adapterpalette (10), wobei ein Transportwagen (20) aufgeladen werden kann, obwohl das Schließorgan (16) aktiviert ist mit Hilfe des Mittels zur beweglichen Lagerung des Schließorgans (16) an seiner Achse (13) oder;

- Deaktivierung des Schließorgans (16) der Adapterpalette (10) vor Aufschieben mindestens eines Transportwagens (20) auf die Adapterpalette (10) **durch** Drehung des Betätigungsmittels der Adapterpalette (10) um die Achse (13) des Schließorgans (16), wobei **durch** Drehung der Achse (13) das Schließorgan (16) in seine deaktivierte Stellung gedreht wird; woraufhin mindestens ein Transportwagen (20) auf die Adapterpalette (10) aufgeschoben wird; und  
- wonach mindestens eines der Schließorgane (16) betätigt wird durch lineare Bewegung des Betätigungsmittels der Adapterpalette (10) in Richtung der Achse (13) des Schließorgans (16) zur Sicherung des Transportguts.

5. Verfahren zur Handhabung von Transportgut nach Anspruch 4, **dadurch gekennzeichnet, dass** der letzte Transportwagen (20) einer Reihe ohne Bewegung des Betätigungsmittels auf die Adapterpalette (10) geladen wird.

6. Verfahren zur Handhabung von Transportgut nach Anspruch 4 oder 5, **dadurch gekennzeichnet, dass** die Adapterpalette (10) über ihre Hebepunkte (18) angehoben wird.

7. Verfahren zur Handhabung von Transportgut nach Anspruch 4, **dadurch gekennzeichnet, dass** die Adapterpalette (10) zum Entladen vorbereitet wird, indem das Betätigungsmittel in einer linearen Richtung bewegt wird.

**Revendications**

1. Palette d'adaptateur, comprenant :

- au moins un pont portant (12) pour recevoir les roues (22) d'un châssis roulant (20), les ponts portants (12) étant séparés par au moins un point de levage (18) pour recevoir les fourches de levage d'un chariot élévateur à fourche ; et  
- au moins un élément de verrouillage (16) pour entrer en prise avec le châssis roulant (20) ;  
- un moyen d'activation pour manipuler l'élément de verrouillage (16), dans laquelle le moyen d'activation comprend au moins un levier (14) et dans laquelle ledit moyen d'activation (14) est adapté pour désactiver ledit élément de verrouillage (16) lorsqu'il est tourné et adapté pour activer ledit élément de verrouillage (16) lorsqu'il est déplacé dans une direction linéaire

**caractérisée en ce que**

- le levier (14) est adapté pour déplacer un essieu (13), auquel des éléments de verrouillage (16) sont fixés, et **en ce que**  
- raccordé audit élément de verrouillage (16) est un moyen pour suspendre ledit élément de verrouillage (16) par rapport à son essieu (13), dans laquelle un châssis roulant (20) peut être chargé bien que ledit élément de verrouillage (16) soit activé.

2. Palette d'adaptateur selon la revendication 1, **caractérisée en ce que** ledit mouvement de rotation est autour dudit essieu (13).

3. Palette d'adaptateur selon la revendication 1, **caractérisée en ce que** ledit mouvement linéaire est dans

la direction axiale dudit essieu (13).

4. Procédé de manipulation de marchandises par un système comprenant au moins un châssis roulant (20) et une palette d'adaptateur (10), qui comprend un moyen d'activation pour l'activation et la désactivation d'un élément de verrouillage (16), qui comporte un essieu (13) et un moyen pour suspendre ledit élément de verrouillage (16) par rapport à son essieu (13), **caractérisé par** :
- la propulsion d'au moins un châssis roulant (20) sur la première rangée de la palette d'adaptateur (10), dans lequel un châssis roulant (20) peut être chargé bien que ledit élément de verrouillage (16) soit activé à l'aide dudit moyen pour suspendre ledit élément de verrouillage (16) par rapport à son essieu (13) ; ou
  - avant la propulsion d'au moins un châssis roulant (20) sur ladite palette d'adaptateur (10), la désactivation de l'élément de verrouillage (16) de la palette d'adaptateur (10) en faisant tourner le moyen d'activation de ladite palette d'adaptateur (10) autour de l'essieu (13) dudit élément de verrouillage (16), tournant ainsi ledit essieu (13), ledit élément de verrouillage (16) tourne dans sa position désactivée ; après cela la propulsion d'au moins un châssis roulant (20) sur ladite palette d'adaptateur (10) ; et
  - après cela l'activation d'au moins un desdits éléments de verrouillage (16) en déplaçant linéairement le moyen d'activation de ladite palette d'adaptateur (10) dans la direction dudit essieu (13) dudit élément de verrouillage (16) pour fixer les marchandises.
5. Procédé de manipulation de marchandises selon la revendication 4,  
**caractérisé en ce que** le dernier châssis roulant (20) d'une file est chargé sur ladite palette d'adaptateur (10) sans déplacer ledit moyen d'activation.
6. Procédé de manipulation de marchandises selon les revendications 4 ou 5,  
**caractérisé en ce que** ladite palette d'adaptateur (10) est levée à partir de ses points de levage (18).
7. Procédé de manipulation de marchandises selon la revendication 4,  
**caractérisé en ce que** ladite palette d'adaptateur (10) est préparée pour le déchargement en déplaçant ledit moyen d'activation dans une direction linéaire.

55

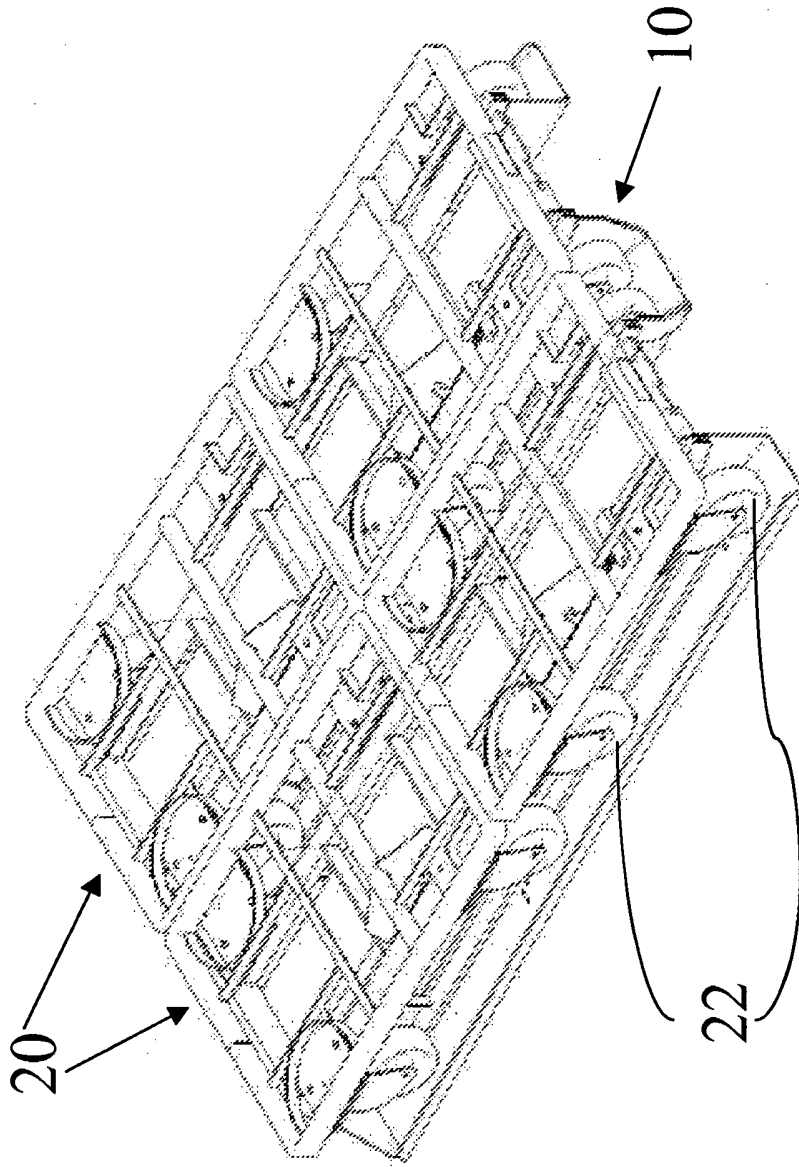

Fig. 1

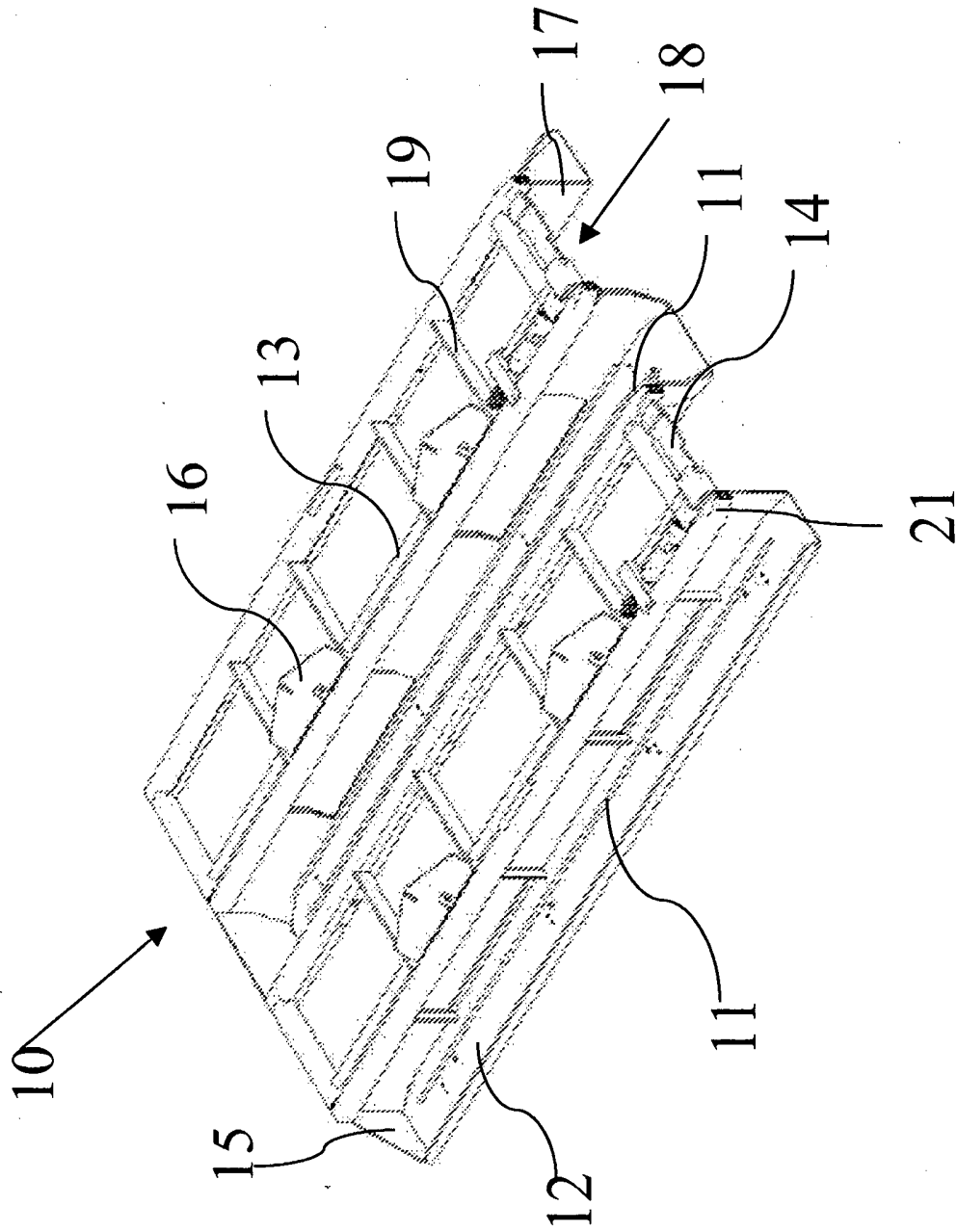

Fig. 2

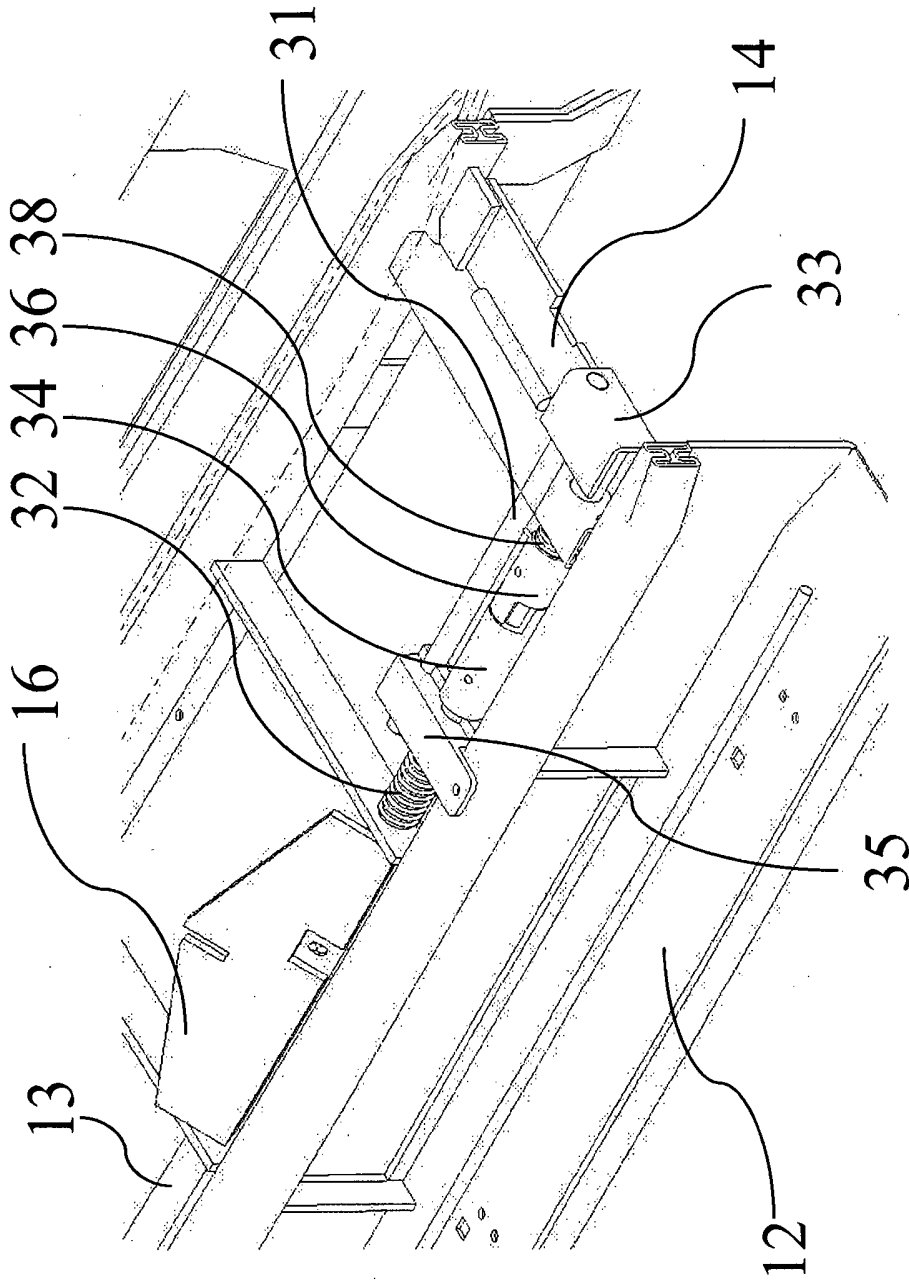

Fig. 3

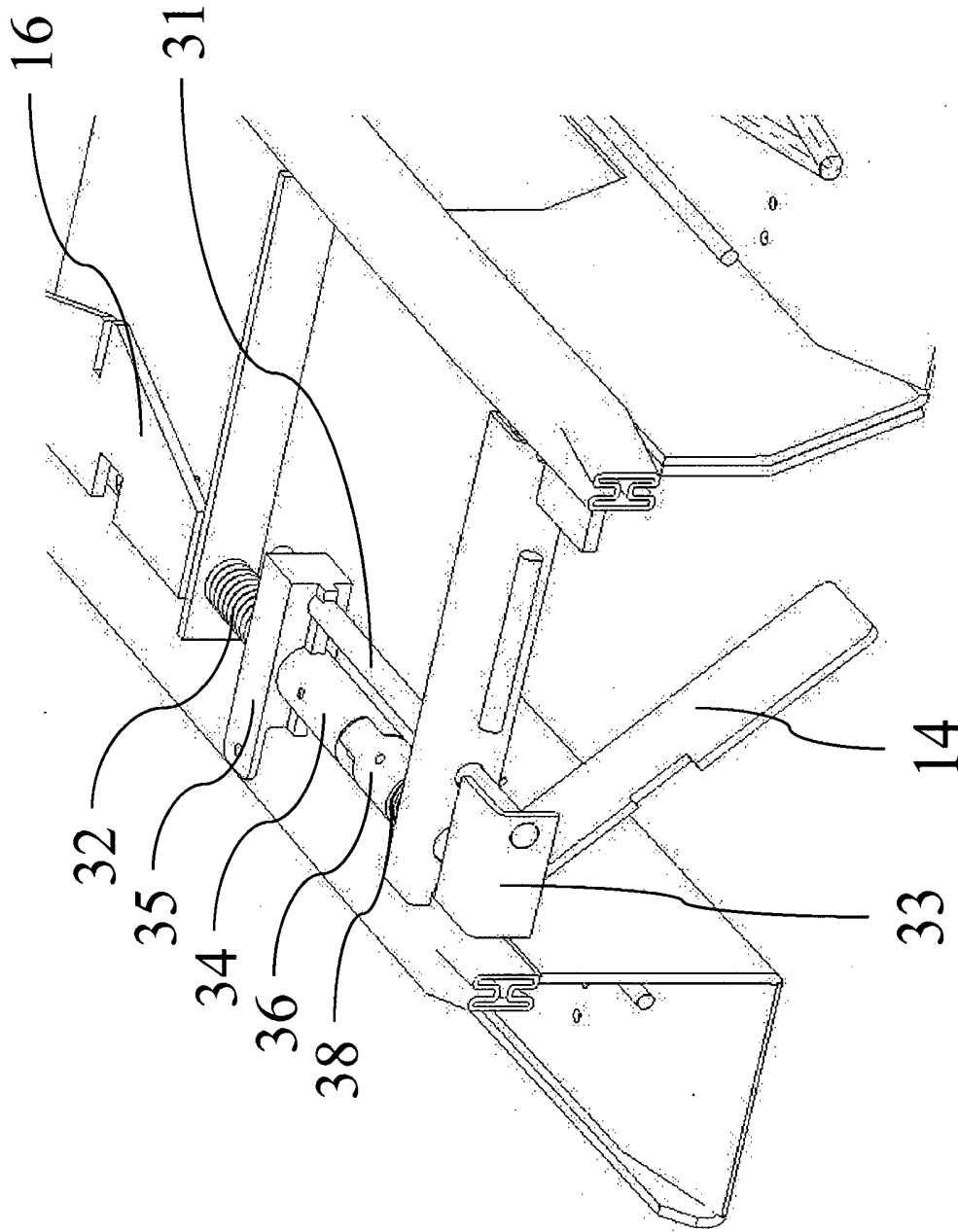

Fig. 4

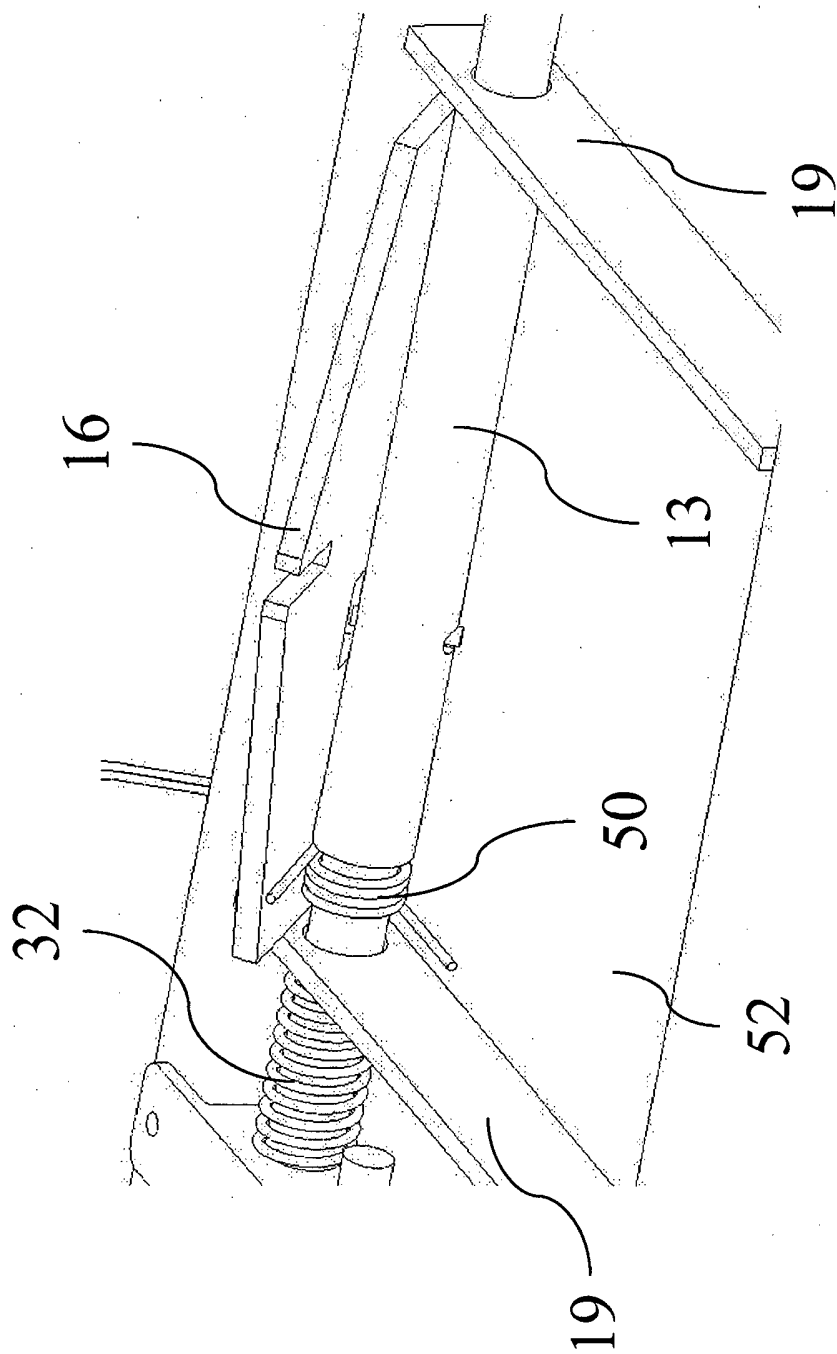

Fig. 5

**REFERENCES CITED IN THE DESCRIPTION**

*This list of references cited by the applicant is for the reader's convenience only. It does not form part of the European patent document. Even though great care has been taken in compiling the references, errors or omissions cannot be excluded and the EPO disclaims all liability in this regard.*

**Patent documents cited in the description**

- GB 2416527 A [0003] [0004]
- DE 20219319 U1 [0003]
- DE 202006007202 U1 [0003]

714316/DO

## ADAPTER RAKLAP ÉS RAKOMÁNY KEZELÉSÉRE SZOLGÁLÓ ELJÁRÁS

### SZABADALMI IGÉNYPONTOK

1. Adapter raklap, amely magában foglal:

- legalább egy teherviselő felületet (12) egy szállítókocsi (20) kerekeinek (22) befogadására, a teherviselő felületeket (12) egymástól elkülöníti legalább egy emelési pont (18) egy villás targonca emelővillájának befogadására; és

- legalább egy reteszelőelemet (16) a szállítókocsival (20) való összekapcsolódásra;

- aktiváló eszközt a reteszelőelem (16) kezelésére, amely aktiváló eszköz magában foglal legalább egy működtető kart (14), és amely aktiváló eszköz (14) úgy van kialakítva, hogy inaktíválja a reteszelőelemet (16), amikor elforgatjuk, és úgy van kialakítva, hogy aktiválja a reteszelőelemet (16), amikor egyenes vonalú irányban mozgatjuk,

azzal jellemezve, hogy

- a működtető kar (14) úgy van kialakítva, hogy mozgasson egy tengelyt (13), amelyhez reteszelőelemek (16) vannak hozzáerősítve, és azzal, hogy

- a reteszelőelemhez (16) hozzá van kapcsolva egy eszköz a reteszelőelem (16) felfüggesztésére a tengelyéhez (13) képest, és egy szállítókocsi (20) annak ellenére berakható, hogy a reteszelőelem (16) aktiválva van.

2. Az 1. igénypont szerinti adapter raklap,

azzal jellemezve, hogy a forgó mozgás a tengely (13) körül történik.

3. Az 1. igénypont szerinti adapter raklap,

azzal jellemezve, hogy az egyenes vonalú mozgás a tengely (13) axiális irányában történik.

4. Eljárás rakomány kezelésére egy olyan rendszerrel, amely legalább egy szállítókocsiból (20) és egy adapter raklapból (10) áll, amely magában foglal egy aktiváló eszközt egy reteszelőelem (16) aktiválására és inaktíválására, amely reteszelőelemnek van egy tengelye (13) és egy eszköze a reteszelőelem (16) felfüggesztésére a tengelyéhez (13) képest,

azzal jellemezve, hogy

- rávezetünk legalább egy szállítókocsit (20) az adapter raklap (10) első sorára, és egy szállítókocsi (20) annak ellenére berakható, hogy a reteszelőelem (16) aktiválva van annak az eszköznek a segítségével, amely a reteszelőelemnek (16) a tengelyéhez (13)

képest való felfüggesztésére szolgál, vagy;

- a legalább egy szállítókocsinak (20) az adapter raklapra (10) való rávezetését megelőzően inaktíváljuk az adapter raklap (10) reteszelőelemét (16) az adapter raklap (10) aktiváló eszközének a reteszelőelem (16) tengelye (13) körüli elforgatásával, elforgatva ezzel a tengelyt (13), a reteszelőelem (16) az inaktívált helyzetébe forog; azután rávezetünk legalább egy szállítókocsit (20) az adapter raklapra (10); és

- ezt követően aktiváljuk a reteszelőelemek (16) legalább egyikét az adapter raklap (10) aktiváló eszközének egyenes vonalban történő mozgatásával a reteszelőelem (16) tengelyének (13) irányában, hogy rögzítsük a rakományt.

5. A 4. igénypont szerinti eljárás rakomány kezelésére,

azzal jellemezve, hogy egy sornak az utolsó szállítókocsiját (20) az aktiváló eszköz mozgatása nélkül rakjuk fel az adapter raklapra (10).

6. A 4. vagy az 5. igénypont szerinti eljárás rakomány kezelésére,

azzal jellemezve, hogy az adapter raklap (10) az emelési pontjaitól (18) el van emelve.

7. A 4. igénypont szerinti eljárás rakomány kezelésére,

azzal jellemezve, hogy az adapter raklapot (10) az aktiváló eszköz egyenes vonalú irányban való mozgatásával előkészítjük a kirakodásra.

(A meghatalmazott)

Művelődési Dén. no Katalin  
 Szociális Szolgálat  
 Szociális Szolgálat  
 H-1024 Budapest, Andrássy út 115.  
 Telefon: 06-1-461-4000  
 E-mail: katalin@szoci.hu