

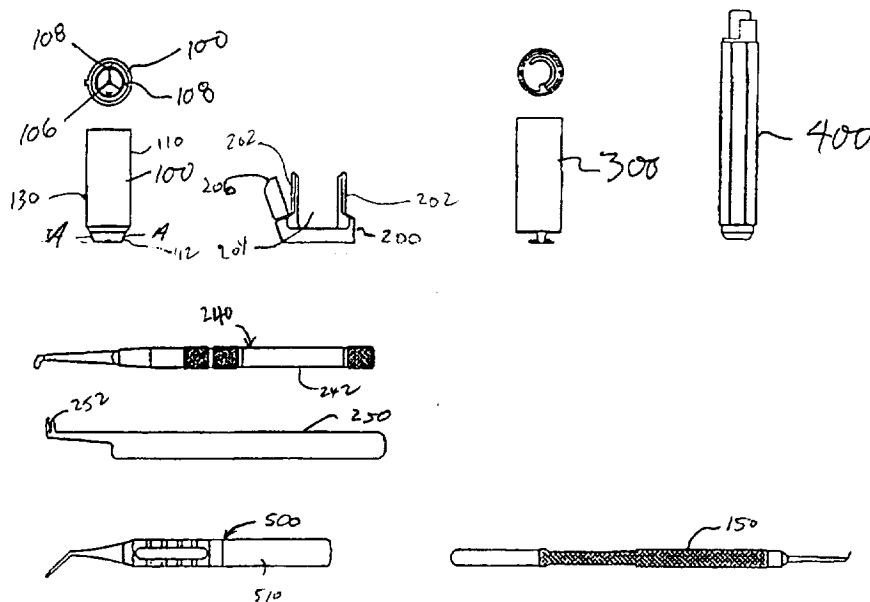

INTERNATIONAL APPLICATION PUBLISHED UNDER THE PATENT COOPERATION TREATY (PCT)

<p>(51) International Patent Classification <sup>6</sup> : <b>A61F 9/007</b></p>	<p><b>A2</b></p>	<p>(11) International Publication Number: <b>WO 98/03136</b> (43) International Publication Date: 29 January 1998 (29.01.98)</p>
<p>(21) International Application Number: PCT/US97/12684 (22) International Filing Date: 19 July 1997 (19.07.97) (30) Priority Data: 60/020,996 19 July 1996 (19.07.96) US Not furnished 18 July 1997 (18.07.97) US (71) Applicant (for all designated States except US): KERAVISION, INC. [US/US]; 48630 Millmont Drive, Fremont, CA 94838-7353 (US). (72) Inventors; and (75) Inventors/Applicants (for US only): SILVESTRINI, Thomas, A. [US/US]; 1701 Las Trampas Road, Alamo, CA 94507 (US). SCHOLL, John, Anthony [US/US]; 14 Woodranch Circle, Danville, CA 94506 (US). PROUDFOOT, Robert, A. [US/US]; 3511 Tracy Drive, Santa Clara, CA 95051 (US). GANDIONCO, Isidro, Matias [US/US]; 36520 Alder Court, Fremont, CA 94536 (US). (74) Agents: CANNON, Alan, W. et al.; Morrison &amp; Foerster LLP, 755 Page Mill Road, Palo Alto, CA 94304-1018 (US).</p>		<p>(81) Designated States: AL, AM, AT, AU, AZ, BA, BB, BG, BR, BY, CA, CH, CN, CU, CZ, DE, DK, EE, ES, FI, GB, GE, HU, IL, IS, JP, KE, KG, KP, KR, KZ, LC, LK, LR, LS, LT, LU, LV, MD, MG, MK, MN, MW, MX, NO, NZ, PL, PT, RO, RU, SD, SE, SG, SI, SK, SL, TJ, TM, TR, TT, UA, UG, US, UZ, VN, YU, ZW, ARIPO patent (GH, KE, LS, MW, SD, SZ, UG, ZW), Eurasian patent (AM, AZ, BY, KG, KZ, MD, RU, TJ, TM), European patent (AT, BE, CH, DE, DK, ES, FI, FR, GB, GR, IE, IT, LU, MC, NL, PT, SE), OAPI patent (BF, BJ, CF, CG, CI, CM, GA, GN, ML, MR, NE, SN, TD, TG).  <b>Published</b> <i>Without international search report and to be republished upon receipt of that report.</i></p>

(54) Title: OPTHAMOLOGICAL INSTRUMENTS AND METHODS OF USE



(57) Abstract

An incision and placement marker (100) is used to place incision and positioning marks on the eye as well as to center a vacuum centering guide. A corneal spreader (150) forms pockets in the corneal tissue at the incision site. Clockwise and counter-clockwise glides (240) ease the insertion of clockwise and counter-clockwise dissector blades. A field dissector inspection gauge (400) is provided to check the planarity and concentricity of dissector gauges. Forceps (500) have a space having a predetermined shape to hold an implant at a predetermined acute angle. A kit includes the incision and placement marker (100), corneal spreader (150), glide (240), field dissector inspection gauge (400), and, optionally, the forceps (500). Methods of using the instruments are also provided.

**FOR THE PURPOSES OF INFORMATION ONLY**

Codes used to identify States party to the PCT on the front pages of pamphlets publishing international applications under the PCT.

AL	Albania	ES	Spain	LS	Lesotho	SI	Slovenia
AM	Armenia	FI	Finland	LT	Lithuania	SK	Slovakia
AT	Austria	FR	France	LU	Luxembourg	SN	Senegal
AU	Australia	GA	Gabon	LV	Latvia	SZ	Swaziland
AZ	Azerbaijan	GB	United Kingdom	MC	Monaco	TD	Chad
BA	Bosnia and Herzegovina	GE	Georgia	MD	Republic of Moldova	TG	Togo
BB	Barbados	GH	Ghana	MG	Madagascar	TJ	Tajikistan
BE	Belgium	GN	Guinea	MK	The former Yugoslav Republic of Macedonia	TM	Turkmenistan
BF	Burkina Faso	GR	Greece			TR	Turkey
BG	Bulgaria	HU	Hungary	ML	Mali	TT	Trinidad and Tobago
BJ	Benin	IE	Ireland	MN	Mongolia	UA	Ukraine
BR	Brazil	IL	Israel	MR	Mauritania	UG	Uganda
BY	Belarus	IS	Iceland	MW	Malawi	US	United States of America
CA	Canada	IT	Italy	MX	Mexico	UZ	Uzbekistan
CF	Central African Republic	JP	Japan	NE	Niger	VN	Viet Nam
CG	Congo	KE	Kenya	NL	Netherlands	YU	Yugoslavia
CH	Switzerland	KG	Kyrgyzstan	NO	Norway	ZW	Zimbabwe
CI	Côte d'Ivoire	KP	Democratic People's Republic of Korea	NZ	New Zealand		
CM	Cameroon			PL	Poland		
CN	China	KR	Republic of Korea	PT	Portugal		
CU	Cuba	KZ	Kazakistan	RO	Romania		
CZ	Czech Republic	LC	Saint Lucia	RU	Russian Federation		
DE	Germany	LI	Liechtenstein	SD	Sudan		
DK	Denmark	LK	Sri Lanka	SE	Sweden		
EE	Estonia	LR	Liberia	SG	Singapore		

## OPHTHALMOLOGICAL INSTRUMENTS AND METHODS OF USE

### CROSS-REFERENCE TO RELATED APPLICATIONS

10           The present non-provisional application hereby claims priority to  
copending provisional application no. 60/020,996, which was filed on July 19,  
1996.

### TECHNICAL FIELD

15           The invention relates to ophthalmosurgical instruments generally, and  
more particularly to corneal implant instruments and methods of use.

### BACKGROUND ART

          Anomalies in the overall shape of the eye can cause visual disorders.  
Hyperopia ("farsightedness") occurs when the front-to-back distance in the eyeball  
20           is too small. In such a case, parallel rays originating greater than 20 feet from the  
eye focus behind the retina. In contrast, when the front-to-back distance of the  
eyeball is too large, myopia ("nearsightedness") occurs and the focus of parallel  
rays entering the eye occurs in front of the retina. Astigmatism is a condition  
25           which occurs when the parallel rays of light do not come to a single point within  
the eye, but rather have a variable focus due to the fact that the cornea is  
aspherical and refracts light in a different meridian at different distances. Some  
degree of astigmatism is normal, but where it is too high, it must often be  
corrected.

          Hyperopia, myopia, and astigmatism are usually corrected by glasses or  
30           contact lenses. Surgical methods for the correction of such disorders are known.  
Such methods include radial keratotomy (see e.g., U.S. Patents Nos. 4,815,463  
and 4,688,570) and laser corneal ablation (see, e.g., U.S. Patent No. 4,941,093).

Another method for correcting those disorders is through implantation of polymeric rings in the eye's corneal stroma to change the curvature of the cornea. Previous work involving the implantation of polymethylmethacrylate (PMMA) rings, allograft corneal tissue, and hydrogels is well documented. One of the devices involves a ring design that allows a split ring to be inserted into a channel dissected in the stromal layer of the cornea using a minimally invasive incision through which the channel for the implant is created and through which the implant is inserted. Techniques for implantation of corneal implants are known. Examples are disclosed in U.S. Patent No. 4,961,744 to Kilmer et al. and PCT publications PCT/US95/00063, PCT/US94/08462, and PCT/US94/08458 all of which are hereby incorporated herein by reference in their entireties.

U.S. Patent No. 4,452,235 to Reynolds describes a method and apparatus for corneal curvature adjustment. The method involves inserting one end of a split end adjusting ring into the cornea of the eye and moving the ring in a circular path until its ends meet. The ends are thereafter adjusted relative to each other until the shape of the eye has assumed a desired curvature whereupon the ends are fixedly attached to maintain the desired curvature of the cornea.

PCT Application No. PCT/US93/03214 filed 7 April 1993 describes a corneal vacuum centering guide and dissector for use in inserting an intrastromal corneal ring ("ICR"). The device is made of up of three major components: a vacuum centering guide, a barrel that fits within the inner bore of the centering guide and to which is attached the third major component, a circular dissecting ring. The three components are further described below.

WO 95/17144 describes a device and method for implanting an intralamellar ring for treatment of ametropia. Two semicircular, strip-like cutting members are mounted on a support means driven by a hand held operating member which is hand turned to form tunnels in the cornea for insetion of a ring therein. Initially, two small incisions are made to start formation of the tunnels with the cutting members.

A Russian language document entitled "Interlayer Refraction Tunnel Keratoplasty In Correcting Myopia and Astigmatism", UDC 617.753.2+617.753.3 - 089:617.713 - 089.844, describes a tunnel keratoplasty technique for attenuating refraction of the myopic eye. The corneal periphery is described as being divided  
5 into 4, 6, 8 or 12 sectors, and tangential cuts are made from the limbus, each having a depth of 0.5mm and a length of 0.5 to 1 mm.

Russian Patent SU (11) 1771730A1 discloses a method of correcting non-compound myopic astigmatism in which band-shaped implants of a predetermined cross-section are inserted into two opposed arc-shaped tunnels of the cornea which  
10 are spaced at a predetermined distance from each other in the meridian of the maximum refractive focus. The implants are pulled into the tunnels for implantation using threads.

Herrick, U.S. Patent No. 4,781,187 discloses a method and implant for refractive keratoplasty in which a plurality of radial corneal incisions are made. A  
15 piece of donor corneal tissue, having a preselected geometric configuration, is inserted into the incisions and sutured in place.

Loomas et al., U.S. Patent No. 5,403,335 discloses a corneal vacuum centering guide and dissector for producing a generally circular interlamellar pathway within the corneal stroma. A generally circular, split intracorneal ring is  
20 inserted into the pathway which is formed by the dissector. U.S. Patent No. 5,403,335 is hereby incorporated by reference herein in its entirety.

Problems have previously been encountered using a sharp tipped instrument in an attempt to form a pocket in the corneal tissue at an incision  
25 location. The sharp tip, rather than merely separating the corneal layers, would accidentally cut all the way through the corneal tissue so that the instrument would actually form an additional incision protruding though the exterior of the corneal tissue.

A need has also been expressed for an easy way to ensure that dissector blades are acceptable for use prior to surgery.

DISCLOSURE OF THE INVENTION

5

An ocular marker includes a support having an end portion. The end portion, includes a marking surface adapted to form a mark on the surface of an eye. A generally I-beam shaped portion is included on the marking surface for placing an incision mark. The marking surface further includes generally crescent shaped portions which outline the desired locations of the implants. Preferably, the crescent shaped portions further include end marks which form a distinctive break with the crescent shapes.

10

15

The support preferably includes a substantially cylindrical main body. A pin extending from an outer wall of the substantially cylindrical main body for interfitting with a vacuum centering guide. The marker further includes a reticle centrally aligned with a longitudinal axis of the substantially cylindrical main body.

20

25

Also disclosed is a corneal spreader having a handle having a first diameter or thickness, an extension extending from the handle and having a second diameter which is less than the first diameter or thickness, and a tip extending from the extension at an obtuse angle. The tip is preferably substantially flat and relatively wide and thin, and has a tip end that is substantially rounded and blunt. Preferably, the tip end is substantially hemispherically shaped. The tip further has tip sides extending from the tip end, which are sharper than the tip end.

30

A glide is disclosed as having a glide handle; a glide blade extending from the glide handle; and a glide foot extending from the glide blade and positioned at an obtuse angle with respect to a longitudinal axis of the glide handle. The glide foot is preferably substantially flat. An additional glide, which is a mirror image of the first glide, is disclosed.

The glide foot extends in a direction perpendicular to the longitudinal axis of the glide handle, by a length which is greater than or equal to a width of the glide blade at a location where the glide blade meets the glide. The glide further includes a threaded rod extending through the handle and having a collet at one end thereof, wherein the threaded rod is releasably mounted to the handle to receive the glide blade in the collet.

A field dissector inspection gauge is disclosed which includes a main body adapted to closely fit an inside diameter of a dissector tool; a post extending from one end of the main body, where the post has a diameter which is smaller than a diameter of the main body, and the post is dimensioned and adapted to extend through an interior circumference of a dissector blade of the dissector tool.

The inspection gauge further includes a fence substantially following the contour of a portion of the post and adapted to closely contour an outer edge of the dissector blade. The fence and the post form an annular recess therebetween.

Preferably, the fence forms a substantially semi-cylindrical arcuate section.

Additionally, the inspection gauge includes a second post extending from an end of the main body opposite the first post. The second post has a diameter which is smaller than the diameter of the main body, but larger than the diameter of the first post. The second post is chamfered at a free end thereof, and the chamfered end is adapted to abut a supporting spoke of the dissecting blade for inspection of the planarity of the dissecting blade.

Still further, forceps are disclosed, which include first and second handles having first and second tips extending therefrom, respectively. Each of the first and second tips have a cut out, wherein the cut outs are adapted to form a space having a predetermined shape, upon closing the first and second tips together. The predetermined shape is adapted to hold an implant at a predetermined acute angle with respect to a perpendicular to a longitudinal axis of the forceps.

A kit is disclosed to include an ocular marker; a corneal spreader; at least one glide; and a field dissector inspection gauge. Additionally, the kit may

include forceps. Still further, the kit may include a pair of glides which are mirror images of one another.

A method of using the above ophthalmological instruments includes:  
centering an incision and placement marker on an eye; marking an incision mark  
5 on the eye with the incision and placement marker; removing the incision and  
placement marker from the eye; making an incision in the corneal tissue of the eye  
in the location of the incision mark; forming a pocket intrastromally at the cite of  
the incision, using a corneal spreader; forming an intrastromal channel using a  
dissector; and inserting a corneal implant into the intrastromal channel.

10 Additionally, the method may include inserting a glide in the pocket to  
facilitate insertion of the dissector for forming the instrastromal channel. Still  
further, the method may include picking up the corneal implant with forceps  
designed to maintain the corneal implant at a predetermined angle with respect to  
the longitudinal axis of the forceps. Also disclosed is the method of checking the  
15 planarity and concentricity of the dissector, prior to use, with a field dissector  
inspection gauge.

#### BRIEF DESCRIPTION OF THE DRAWINGS

20 Figure 1 shows a set of instruments, according to the present invention, for  
placing an implant in the cornea of an eye.

Figures 2 and 3 are end partial views, in perspective, of a preferred  
incision and placement marker according to the present invention;

Figure 4 is a sectional view of Figure 1, taken along lines A-A;

25 Figure 5 illustrates the configuration of a mark provided by the use of a  
marker as shown in Figure 3;

Figure 6 is a front perspective view of the vacuum centering device  
according to the principle of the present invention;

Figure 6A is a perspective view of the vacuum centering device looking  
approximately along the line 2-2 as shown in figure 6;

Figure 6B is a bottom view of the vacuum centering device;

Figure 6C is a partial cross-sectional view of the vacuum centering device looking along the line 4-4 as shown in figure 6B;

5 Figure 6D is a cross-sectional view looking along the line 5-5 as shown in figure 6B;

Figure 6E is a cross-sectional view of the vacuum centering device as placed upon the eye;

10 Figure 6F is a detailed view of section 7-7 as shown in figure 6E depicting the vacuum centering device placed upon the eye while the device is not under vacuum;

Figure 6G is a detailed view of section 7-7 as shown in figure 6E depicting the vacuum centering device placed upon the eye while the device is under vacuum;

15 Figure 6H is a bottom view of the vacuum centering device having a saddle-shaped base showing the outer periphery having an ovaloid projection;

Figure 6I is a cross-sectional view of the vacuum centering device having a saddle-shaped base looking along the line 10-10 as shown in figure 6H;

Figure 6J is a cross-sectional side view of the vacuum centering device having a saddle shaped base looking along the line 11-11 as shown in figure 6H;

20 Figure 6K is a projection of an oval onto a sphere, representing an eye, this projection indicating the saddle shape of the invention as shown in figure 6G;

Figure 7 is an end view of an incision and placement marker according to the present invention;

25 Figure 7A is a longitudinal section view of an incision and placement marker taken through lines A-A in Figure 7;

Figure 8 shows a plan view of a spreader according to the present invention;

Figure 8A shows a partial view of the spreader of Figure 8, starting from cut lines A-A;

Figure 8B is a partial view similar to that of Figure 8A, but rotated by 90°;

Figure 8C is a sectional view taken along lines C-C in Figure 8B;

Figure 8D is a sectional view taken along lines D-D in Figure 8B;

5 Figure 8E is a magnified view of the tip of Figure 8A starting from cut lines E-E;

Figure 8F is a modification of the tip shown in Figure 8A;

Figure 9 shows an exploded view of a glide according to the present invention;

10 Figure 9A shows a view of a clockwise glide rotated 90° with respect to the view of the glide shown in Figure 1;

Figure 9B shows a view of a counterclockwise guide;

Figure 9C is a partial view showing a glide according to the present invention, used to hold a flap of corneal tissue to allow easier insertion of a dissector blade;

15 Figure 9D is a partial perspective view of the glide blade and glide foot according to the present invention;

Figure 10 is an incision mark detail producing from the procedure charted in Figure 9.

20 Figure 11 shows a plan view of a field dissector inspection gauge according to the present invention, in juxtaposition with a dissector;

Figure 11A is a sectional view, taken along the longitudinal axis, of the inspection gauge inserted into a dissector to gauge blade concentricity, according to the present invention;

25 Figure 11B is an end view of the inspection gauge inserted into a dissector to gauge blade concentricity, according to the present invention;

Figures 11C, 11D, 11E, 11F and 11G show sectional examples of various results possible when the inspection gauge is inserted into a dissector to gauge blade planarity;

30 Figure 11H is a sectional view of the inspection gauge taken along lines II-H in Figure 11;

Figure 12 shows a plan view of forceps in the open position, according to the present invention;

Figure 12A shows an enlarged detailed view of the tips of the forceps in the closed position;

5 Figure 12B shows an enlarged detailed view of the tips of the forceps with a sectional view of an implant held therein; and

Figure 13 shows a flow chart describing a method of placing an implant in a cornea according to the present invention.

### 10 BEST MODE FOR CARRYING OUT THE INVENTION

Figure 1 shows an array of instruments for placing implants in the cornea of an eye. They may be particularly sized for implantation in the cornea of a human eye. The incision and placement marker (100) serves multiple functions in the method according to the present invention. Primarily, marker (100) functions  
15 to leave properly positioned marks on the cornea of a patient with regard to where to form an incision, where the implantable ring segments should be located, and where the ends of the implantable ring segments should be located.

The incision and placement marker (100) has a substantially cylindrical body (110) with a tapered end portion (112). Tapered end portion (112) includes  
20 a marking edge (102) at the end thereof which functions to transfer intended markings to the cornea during use. The marking edge (102) includes an incision marker (104) which is preferably "I-beam" shaped, as shown in Figure 3, for example. The length of the I-beam (104a) makes a mark on the cornea which both  
25 locates where the incision is to be made and indicates the approximate length of the incision to be made. The ends of the I-beam (104b) make marks which serve to more clearly identify the end boundaries of the incision which is to be made. The incision marker (104) may take on shapes other than that of an I-beam, e.g., a "C-shape" box shape. or other shapes, as long as the shape of the marker (104) functions to indicate the location and length of the incision to be made.

The marker crescents (103) form marks to generally delineate the outer diameter of where the implants should be located. The marker crescents (103) may be configured for segments of various arcs. The one shown may be used with segments subtending a  $150^\circ$  arc, for example, as shown in Figure 7. The marks formed by the marker crescents generally indicate where the outer edges of the implant segments should be located. Gaps (107) define a clear separation between the incision marker (104) and the crescent markers (103) to maintain clear definition between the marks formed by these respective markers. For example, when the marker crescents (103) subtend approximately  $150^\circ$  each, gaps (107) combine with the incision marker to form an arc  $\Gamma$  of about  $40^\circ$  as shown in Fig. 7. End markers (105) form distinctive marks at the ends of the crescent marks to indicate where the ends of the implants should be located. These marks inform the individual that is placing the implant where to stop the insetion of the implant, i.e., the end of the implant should line up with a mark formed by end marker (105). A gap (109) is formed between end markers (105). When the marker crescents (103) subtend approximately  $150^\circ$  each, gaps (109) forms an arc  $\Delta$  of about  $20^\circ$ , as shown in Figure 7.

The incision and placement marker (100) further includes a reticle (106) supported by ring (108) which resides interiorly of the tapered end portion 112 as indicated by the position lines IV-IV in Fig. 1, the sectional view of which is shown in Fig. 4. It is noted that the ring (108) and reticle (106) are omitted from the partial views shown in Figures 2 and 3 in order to more clearly show the marking edge (102). Reticle (106) is positioned centrally of the marker (100), i.e., in line with the longitudinal axis of cylinder (110).

The tapered end portion (112) is tapered so as to form an angle  $\alpha$  of about  $28^\circ$ , as shown in Figures 2 and 7A. However, this taper may range from about  $20^\circ$  to about  $40^\circ$  to accommodate variations in eye curvature. The marker edge (102) is substantially normal to the angle of the tapered end section and is adapted to substantially parallel the corneal surface. Thus, when the marker is applied to the surface of the cornea, the marker edge makes substantially square contact with the

corneal surface and forms a substantially solid, smear free mark on the surface of the cornea.

The incision and placement marker (100) is preferably formed of stainless steel. Most preferably, the entire marker is formed of 316L stainless steel, except for reticle (106) and ring (108) which are most preferably formed of 303 or 304 stainless steel which is readily available in sheet form. However, other materials may be used to form the incision and positioning marker, such as titanium, other stainless steel alloys, and other metals and materials which are known to be dimensionally stable, biocompatible, sterilizable and relatively strong and durable.

Figure 5 is an illustration of the marks (122) that are left on the cornea after placement and then removal of the incision and placement marker (100), the method for which is described in more detail below. Incision mark (124) is in the shape of an "I-beam" and corresponds to the shape of incision marker (104). The incision mark can be located anywhere in the 360° circumference on the eye which is covered by the incision and placement marker. However, it is generally preferred to located the incision mark (124) at the 12 o'clock or 6 o'clock position on the eye (i.e., directly above or below the pupil, respectively), most preferably the 12 o'clock position. The crescent marks (123) correspond to the shapes of the crescent markers (103), and the end marks 125 correspond to the shapes of the end markers (105).

A corneal or stromal spreader (150) is inserted into the incision (124') that is initially made in the location indicated by the incision mark (124). An example of such an incision, and how it relates to the I-beam mark, is shown in Figure 10.

Once inserted into the corneal tissue through the incision, the spreader (150) is manipulated to form a small intrastromal pocket on both sides of the incision. The small intrastromal pockets are formed to facilitate insertion of dissector blades later in the procedure.

As shown in Figure 8, spreader (150) includes a handle (152) an extension (154) and a tip (156). The entire spreader is preferably made of anodized titanium alloy (6 Al, 4V), but may be made of non-anodized titanium alloy, various

stainless steels, and other metals and materials which are known to be biocompatible, sterilizable and relatively strong and durable.

At least the major portion of the shaft of handle (152) is preferably knurled to lessen the chances of the handle slipping from the operators grasp.

5 Additionally, cutouts (153) are provided in opposing positions to greatly enhance the operator's rotational control of the handle. Extension (154) has a much smaller outside diameter than handle (152), and has a tapering outside diameter that gradually decreases toward the end of extension (154) that joins with tip (156).

10 Tip (156) is substantially flat and relatively wide and thin as observed in a comparison of Figures 8A and 8B. Tip (156) extends from extension (154) at an obtuse angle  $\beta$  to the longitudinal axis of extension (154) and handle (152), as shown in Figure 8A. The obtuse angle provides the user with a comfortable handle position when the tip (156) is inserted into the incision. Tip (156) has a tapering thickness  $t$  which decreases in the direction from the extension (154) to the tip end (158).

15 As shown in Figure 8B, the tip end (158) is rounded and is preferably substantially hemispherical. although greater and lesser radii of curvature may be employed to define the tip end. Importantly, the tip end is not knife sharp, but rather, is relatively blunt so as to function to separate tissue along layers, but not to cut. The tip end (158) transitions into the tip sides (160) as the curvature of the tip end (158) gradually straightens into the substantially straight edges of the tip sides (160). The tip sides (160) are sharp, although not knife sharp. A comparison of the relatively dull edge of the tip end (158) and the relatively sharp edges of the tip sides (160) can be seen by comparing the sectional views of Figures 8C and 25 8D, respectively.

With the arrangement of the stromal spreader tip (156) as described, the relatively dull, slightly rounded tip end (158) greatly reduces the risk of perforation of the corneal tissues upon insertion of the tip into the incision.

Additionally, by rotating the spreader using the handle (152), preferably aided by cutouts (153), the stromal layers are can be effectively separated to form a pocket.

Figure 8E illustrates, in an exaggerated way, the transition between the blunt tip end (158) and the relatively sharp edge of a tip side (160), which supports the fact that the insertion of the tip presents a relatively low risk of perforation of the stromal tissues. Once the spreader has been inserted, separation can begin through use of the sharper side edges (160), together with the blunt tip end (158).

Figure 8F shows a variation of the tip shown in Figure 8A. In this variation, the joinder of the tip (156) and extension (154) is formed at the obtuse angle  $\beta$  to the longitudinal axis of extension (154) and handle (152), the same as shown in Figure 8A. However, the majority of the tip that is distal to the joinder of the tip and the extension, i.e., tip (156') is formed at an angle  $\gamma$  with regard to the longitudinal axis of extension (154) and handle (152), and where angle  $\gamma$  is an obtuse angle that is less than obtuse angle  $\beta$ . The remaining features of tip (156') are essentially the same as those described above with regard to tip (156) in Figures 8A-8E.

A set of corneal thickness gauges (250) are provided for indirectly measuring the depth of the incision (124') by measuring the thickness of corneal tissue layers which are separated down to the depth of the incision. One of the gauges (250) is shown in Figure 1, but a set of gauges having varying gaps (252) are typically provided in order to provide a range of measurement capability. A detailed description of the gauges and their use is disclosed in copending application number 08/796,595, filed on February 7, 1997, which is currently pending and which is also hereby incorporated by reference herein in its entirety.

In addition to its marking functions described above, the incision and placement marker (100) functions as a centering guide for placement of the vacuum centering guide (200). The incision and placement marker (100) includes a pin (130) extending radially from the outer wall of cylinder (110). A slot (202) is provided on each side of vacuum centering guide (200) into which pin (130)

slidably fits. The inside diameter of the vacuum centering guide (200) defined by the structures containing slots (202) is slightly larger (preferably about .002 to .003 inches) than the outside diameter of cylinder (110) of incision and placement marker (100). Reticle (106) enables the incision and placement marker (100) to be accurately, centrally placed over the cornea.

The vacuum centering guide (200) is slid over the incision and placement marker (100) making sure to engage pin (130) into one of slots (202). This ensures that window (204) will be properly positioned for ready access to the incision (124's) in the cornea, and for placing the inserts, suturing, etc. A slot (202) is provided on each side of the vacuum centering guide (200) so that it can be positioned on either eye and still be oriented so that the vacuum tube, which attaches to port (206) goes away from the nose rather than across the nose of the patient. When the vacuum tube is positioned across the nose, it sometimes makes contact with the nose, which runs the risk of breaking the vacuum seal between the vacuum centering guide and the eye.

A detailed description of a vacuum centering guide is given in Loomas, U.S. Patent No. 5,403,335, which was incorporated by reference above, and in copending application number 08/796,595, filed on February 7, 1997, which is incorporated by reference above. A preferred embodiment of a vacuum centering guide for use in the present invention is shown in Figures 6 - 6K. The vacuum centering device generally includes a main base portion which includes a sealing chamber and at least one guide support member. Top and Bottom perspective views of a vacuum centering device (1100) according to the principles of the present invention are shown in Figures 1 and 2. The vacuum centering device (1100) has a base (1102). In a preferred embodiment, guide support members (1118, 1119) extend substantially vertically from the base (1102) and are positioned opposite one another. The base (1102) includes a sealing chamber or vacuum space (1215) to which vacuum pressure may be applied by way of tubular connection (1112) which has an interior lumen (1114) in fluid communication with vacuum port (1204) inside the vacuum space (1355).

The guide support members (1118, 1119) have guide features or surfaces for receiving and accurately positioning a surgical instrument which is to be used. Such guide surfaces may have any suitable shape to mate with said instrument. In the preferred embodiment shown in Figures 1 through 8, guide support members  
5 (1118, 1119) have a cylindrical guide surface (1106) for receiving and mating cylindrical instrument.

Mating cylinders are particularly useful when a mating surgical instrument is required to be rotated relative to the vacuum centering device (1100) about the central axis (1210, see Figures 4 and 5) during a surgical procedure. Such rotation  
10 is commonly required, for example, when forming intrastromal channels using circular dissectors. The cylindrical guide surfaces (1106) provide free rotation of a mating cylindrical instrument within the vacuum centering device (1100) and yet have sufficient height to prevent unacceptable angular movement of the surgical instrument.

If relative rotation of the surgical instrument and the vacuum centering device (1100) is not desired, one or both of the guide support members (1118, 1119) may optionally be constructed with a feature that engages the surgical instrument to prevent rotation. In a preferred embodiment, guide support  
15 members (1118, 1119) have open-ended slots (1110, 1111). The open-ended slots (1110, 1111) engage one or more pins or protrusions (not shown) on a mating surgical instrument to prevent rotation of the surgical instrument about the central axis (1210). Open-ended slots (1110, 1111) may also be use to key or lock a  
20 surgical instrument into one or more rotational positions relative to the vacuum centering device (1100). In the preferred embodiment of Figure 1, a surgical instrument having a mating pin or protrusion would have two fixed positions that  
25 exactly 180 degrees apart.

The maximum angular movement or a surgical instrument allowed by the guide surfaces (1106) is a function of the clearance between the mating surfaces of the surgical instrument and the guide surfaces (1106), the height of the guide  
30 surfaces (1106), and the total subtended angle of the guide surfaces (1106). To

improve both visual access and instrument access by the surgeon, guide surfaces (1106) subtend less than 360° around the base (1102). Preferably, each guide support member (1118, 1119) and associated guide surface (1106) subtend an arc angle of between about 15° to about 360°. Most preferably, the subtended arc angle for each guide support member (1118, 1119) and associated guide surfaces (1106) will be between about 20° and 45°. As seen in the Figure 1, this arrangement leaves adequate open area between the guide support members to allow the surgeon to view the eye during surgery as well as access the eye with any necessary surgical instrument.

As mentioned above, the base (1102) has a sealed chamber or vacuum space (1355). Referring to Figures 2 through 6, the vacuum space 355 is generally bounded by an inner wall (1302) and an outer wall (1304). The inner wall may form a second cylindrical guide surface (1108) to assist guide surfaces (1106) in controlling the position of a surgical instrument.

An important aspect of the vacuum centering device (1100) is the shape of the outer wall (1304). Outer wall (1304) is constructed to have a reduced profile surface (1104) which provides for an improved fit of the base (1102) between the upper and lower eyelids. The surface (1104) may be sloped, tapered, flared, chamfered, radiused, or otherwise shaped to provide a lower profile above the surface of the eye. The reduced profile allows the vacuum centering device (1100) to be fixed to the eye with much less severe retraction of the surrounding eyelids. This in turn provides increased stability of the of the vacuum centering device as well as increased patient comfort.

The number of radial vanes (1204) may be positioned within the vacuum space to provide contact surfaces (1202) for contacting the eye. These contact surfaces are employed to engage the surface of the eye to provide resistance to rotation of the vacuum centering guide (1100) against torsional loading, for instance from a rotating surgical instrument. The radial vanes (1204) and associated contact surfaces (1202) also serve to prevent the surface of the eye to be pulled in too far within the vacuum space upon application of vacuum pressure.

Because the low profile outer wall may be in close proximity to the surface of the eye, a number of radial vanes (1204) may be positioned as shown to prevent the eye from being drawn into the vacuum space to such an extent that it substantially impairs or even completely blocks the vacuum space (1355).

5 Referring now to Figure 6, the vacuum centering device (1100) is shown in positioned on the surface of a mammalian eye (1350). The sealed chamber or vacuum space (1355) is completed as first sealing region (1206) associated with inner wall (1302) and second sealing region (1208) associate with outer wall (1304) engage the surface of eye (1350).

10 Figure 7 is a magnified view of a portion of the vacuum space (1355) positioned against the surface of the eye (1350). Figure 7 shows more clearly the preferred details of the first sealing region (1206) and second sealing region (1208) before the application of vacuum pressure to the vacuum space (1355). Both the first and second sealing regions (1206, 1208) are preferably surfaces that  
15 tend to contact the surface of the eye on an edge. First sealing region (1206) is approximately at an angle of between 25° and 65°, preferably 45°, with the central axis (1210) and contacts the eye (1350) at first edge (1362). Second sealing region (1208) is preferably at about 90° to said central axis (1210) and contacts the surface of the eye (1350) at second edge (1364).

20 As vacuum pressure is applied to the vacuum space (1355) the first edge (1362) and the second edge (1364) begin to deform and dig into the surface of the eye (1350). This initial edge contact of the first and second sealing regions (1206, 208) greatly improves the ability of the vacuum centering device to seal against the eye (1350). In that way, a lower overall pressure may be applied to effectuate  
25 proper sealing, and therefore, a lower intraocular pressure will result during surgery. To obtain the proper sealing functions outline above, the inner and outer walls are preferably made of relatively stiff materials. Preferably the vacuum centering device is made from stainless steel or titanium, but many plastics and  
30 synthetic or natural rubbers having a hardness above Shore A 90° have been found to be sufficient.

Another preferred aspect of the present invention is illustrated with respect to Figures 9 through 12 and involves a construction having a non-circular outer wall. As will be discussed below, a non-circular outer wall provides a larger contact area with the surface of the eye which in turn facilitates the use of lower applied pressures. In addition, a non-circular wall has a projected contact path around the generally spherical eye that yields improved resistance to translational and rotational slippage.

As shown in Figure 9, the vacuum centering device (1500) has a base (1501) which has generally vertical guide support members (1518, 519) having guide surfaces (1506) and optional open ended slots (1510) in the manner described above. Inner wall (1502) and outer wall (1504) form vacuum space (1555). Outer wall (1504) has a low-profile exterior surface (1508) adapted in close proximity to the surface of the eye (not shown) as described above with reference to Figures 1 through 8. The depth (1528) of the vacuum space (1555) may range from 0.200 inches to 0.010 inches and is typically in the range of about 0.020 inches to about 0.100 inches.

Inner wall (1502) has a first sealing region (1512) and outer wall has a second sealing region (1514). The vacuum space (1555) is completed as the sealing regions, are caused to seal against the surface of the eye upon the application of a vacuum pressure through vacuum port (1516) by way of connecting tube (1112). As described above, the first and second sealing regions (1512, 1514) are constructed to engage the eye at their respective edges before the application of vacuum pressure.

An important aspect of this embodiment is that the outer wall (1504) is non-circular. In a preferred embodiment, the profile of the second sealing region (1514) associated with the outer wall (1504) is ovaloid as viewed from the central axis (1570). Most preferably, the sealing region has a profile that is elliptical as shown in Figure 9, having a major axis (1521) and a minor axis (1520).

Referring to Figure 12, the elliptical shape (1552) of the outer wall (1504) and the second sealing region (1514) results in a complex "saddle-shape" (1550) when projected onto the spherical shape of the eye.

5 The shape (1550) taken by the second sealing region (1514) is more effective in many respects. First, it provides a better fit to a patient's eye as it interferes less with a patient's eye lids. The ovaloid shape more closely resembles the shape of an open eye. Second, this shape (1550) of the second sealing region (1514) advantageously resists torsional loading and improves translations stability over plain circular designs.. Additionally, the ovaloid shape can be maximized to  
10 provide greater coverage of the eye than a similar device utilizing a circular profile. This provides greater area for the vacuum to pull on, thereby increasing the force with which the device is held in place; also, it provides space for larger or more vanes adapted to prevent rotation.

Alternately, the ovaloid shape can be used to minimize the height of the  
15 device lessening the need to retract tissue to accommodate it. The decrease in overall height and subsequent loss of vacuum area that would be lost for a circular device can be recovered with the extending the outer wall around the eye in the direction of major axis (1521), thereby adding vacuum area. The preferred embodiment of the present invention makes a compromise between lessening the  
20 required height of the device to help aid the critical advantage offered by the sloped aspect of the outer wall and maximizing the area for the vacuum to pull on.

The preferred variant of the vacuum space (1555) again contains a number of vanes which serve to help prevent rotation of the support base during the ophthalmic operation. Increasing the number of vanes also reduces intraocular  
25 pressure as the vacuum force over the eye is distributed over a larger area. Additionally, the use of a greater number of vanes allow the use of a lower vacuum to hold the device to the eye. The pressure range acceptable for use with the vacuum centering device described herein in the range of 0 - 30 inches Hg.

Figure 13 shows an alternate embodiment for the guide support members  
30 that provide guide surfaces (1612) for the surgical instruments. In this

embodiment, the vacuum centering device has a generally cylindrical bore having a top ring (1602) and access windows (1604, 1605) for visual and instrument access. The top ring may be provided with anti-rotation open-ended slots as shown.

5           After sliding the vacuum centering guide into position over the incision and placement marker (100), both components are centrally placed over the eye. This centering process is performed by using the reticle (106) to center the pieces, in the same way that the reticle (106) was used to center the incision and placement marker (100) for marking. The incision and placement marker (100)  
10           and the dissectors (300) (discussed below) have equal outside diameters, which ensures that the dissectors (300) will track along the marks (122) which have been left on the eye by the incision and placement marker (100).

          Centering of the incision and placement marker (100) is preferably aligned with the actual incision mark (124') to ensure that one of the windows (204) in the vacuum guide (200) is aligned with the incision (124') so that the operator can  
15           easily access the incision (124'). Upon successful centering of the vacuum centering guide (200) and establishment of a vacuum between the eye and the vacuum centering guide (200), the incision and placement guide (100) is removed.

          A glide (240) is next inserted through the incision (124') and into one of  
20           the pockets created by the stromal spreader (150). Glide (240) is used to hold a flap of corneal tissue at the incision, to expand the incision and pocket created by the stromal spreader to allow easier insertion of the dissector blade, as shown in the partial view of Figure 9C.

          The glide 240 includes a glide handle (242) a glide blade (244) and a glide  
25           foot (246). All components are preferably made of stainless steel. The glide handle is most preferably made from 303 stainless steel and the glide blade and foot are most preferably made from a chemically etched sheet of 17-7 PH stainless steel, although other materials may be used to form the glide, such as titanium,  
30           other stainless steel alloys, and other metals and materials which are known to be dimensionally stable, biocompatible, sterilizable and relatively strong and durable.

As shown in Figures 9A and 9B, the glides (240) are designed to be a paired set, as one is provided for assisting in the insertion of a clockwise dissector and the other is provided for assisting in the insertion of a counterclockwise dissector. The clockwise glide (240) shown in Figure 9A, has a foot (246) which is substantially flat and is angled with respect to the longitudinal axis of the handle (242) at an angle  $\delta$  of about  $100^\circ$  to  $130^\circ$ , more preferably about  $110^\circ$  to  $120^\circ$ . Similarly, the foot (246) of the counterclockwise glide is angled at the same angle  $\delta$ , but this foot extends in an opposite direction to the foot of the clockwise glide. In both cases of the clockwise and counterclockwise glides (242), the foot (246) extends in a direction perpendicular to the longitudinal axis of the handle (242), from the edge of the blade (244) by a length (247) which is at least equal to half the width  $w$  of the blade (244) where the blade (244) meets the foot (246). Preferably the length (247) is about equal to or slightly greater than the width  $w$ , up to about  $1.5w$ .

Figure 9 shows a partially exploded view of a glide (240). Handle (242) is preferably knurled at (241) to facilitate nonslip handling and improve maneuverability of the glide by the operator. Handle (242) is hollow and substantially tubular. A threaded shaft (260) passes through handle (242) and includes a collet (248) at one end thereof which extends from one end of the handle (242) as shown in Figure 9. A threaded end (243) (which is also preferably knurled) of the handle (242) mates with the threads (261) on threaded shaft (260). Blade (244) includes a reduced width, straight end (244a) which is dimensioned to fit within the slot (249) provided by collet (248) when threaded end (243) is not torqued down against handle (242) via threads (261). After insertion of straight end (244a) within the slot (249), the threaded end (243) is torqued down against handle (242) via threads (261) to cause collet (248) to securely clamp the straight end (244a) of the glide blade (244) in its operative position.

As mentioned above, the glide (240) allows easier insertion of the dissector blade, as shown in the partial view of Figure 9C. Figure 1 further shows an example of a counterclockwise dissector (300) which is used to form an

intrastromal channel in which an implant will be located. Once the vacuum centering guide (200) is centered and affixed to the surface of the eye, the incision and placement marker (100) is removed from its position within the vacuum centering guide (200) and the counter-clockwise dissector barrel (300) is inserted into the central bore of the vacuum centering guide (200). With the assistance of the counter-clockwise glide (240) described above, the counter-clockwise dissector is inserted into the incision, as shown in Figure 9C. A detailed description of the counterclockwise dissector, as well as its counterpart clockwise dissector, is given in copending application no. 08/796,595, filed on February 7, 1997, which is currently pending, and which was incorporated by reference above.

Further, the vacuum centering guide, clockwise and counterclockwise dissectors and corneal thickness gauges may be constructed as described in PCT publication PCT/US95/00063 entitled "System For Inserting Material Into Corneal Stroma" which is hereby incorporated herein by reference in its entirety.

Figure 1 shows a field dissector inspection gauge (400) according to the present invention. Fig. 11A shows the field dissector inspection gauge (400) in juxtaposition with a dissector (300). The dissector (300) is a very critical instrument and must be within fairly narrow limits of tolerance in order to form a channel both safely and successfully, meaning that the intended vision correction results. If a dissector blade is malformed, or gets knocked out of concentricity and/or planarity, any channels resulting from use of that dissector might make channels that are not circular, not in the right place, or diving and, ultimately posterior perforation, or raising and anterior perforation could result.

Accordingly, the field dissector inspection gauge (400) was developed to provide a portable, accessible and easy to use tool for the operator to determine whether or not a dissector blade is within acceptable limits of concentricity and planarity. Ideally, the blade (310) should be perfectly planar and perpendicular to the longitudinal axis of the dissector (300), as shown in Figure 11. Also ideally, the dissector blade (310) should be perfectly concentric with the circumference of the dissector (300) as shown in Figure 11B. In reality, for reasons such as

dropping of an instrument, entangling more than one dissector blade during sterilization, etc, a dissector blade may be bent out of its intended plane or concentricity or both.

5 The inspection gauge (400) includes a main body (402) which is dimensioned to fit closely within the inner circumference of the dissector (300). The main body is formed to be polygonal in cross-section, preferably octagonal, but other polygons such as hexagons, pentagons, decagons, etc, are acceptable. Preferably, Any polygon shape used should have radiused outer edges (404), however, as shown in Figure 11H, in order to closely and smoothly fit the inside  
10 circumference of the dissector (300). Polygonal cross sections are preferable to a circular cross-section, since a circular cross-section was found to cause the inspection gauge to hang up inside the cylindrical barrel of the dissector (300), due to capillary action, if even a slight amount of moisture was present on the exterior of the inspection gauge at the time of insertion.

15 The entire inspection gauge (400) is preferably made of DELRIN, but it may be made of other materials that are sterilizable, not a bio-hazard that sheds bits of itself off onto the instruments during inspection, and very dimensionally stable, so that after it has been sterilized several times the dimensions do not change, melt, curl up, twist, or distort in any manner.

20 A post (406) extends from one end of the main body (402). Post (406) is dimensioned to extend through the interior of the circumference circumscribed by the inner edge of the dissector blade (310), as shown in Figure 11B. Additionally, a fence (408) is formed as an arcuate section, preferably a semi-circular arcuate section, that extends from the main body (402) and is dimensioned to closely  
25 contour the outer edge of the dissector blade (310) as shown in Figure 11B. The placement of post (406) and fence (408) is such that an annular recess is formed that forms the contour of a properly concentric dissector blade. This arrangement checks both the outside diameter and the inside diameter of dissector blade.

30 Thus, when the inspection gauge (400) in the orientation shown in Figures 11 and 11A is inserted into a dissector (300), to detect the concentricity of the

dissector blade (310), the blade (310) is determined to be within acceptable limits of concentricity if the inspection gauge (400) moves up and down freely. If the dissector blade (310) contacts the post (306) and does not move into the gap (410), this is an unacceptable situation indicating that the dissector blade (310) has  
5 been bent inwardly out of acceptable concentricity limits and the dissector would not be useable. Likewise, if the dissector blade was not concentric due to having been outwardly, it would contact or catch on the fence (408) and would not be able to move past the fence and into the gap (410). This also would be unacceptable and the dissector would not be useable.

10 The bottom end of the inspection gauge shown in Figure 11 includes a second post (412) which extends from the main body (402). Second post (412) has a diameter which is smaller than that of the main body (402), but larger than that of post (406). The end of post (412) is chamfered which dimensions the end to closely conform with the spoke (310') which connects dissector blade (310) to  
15 the dissector body (300). The end surface (415) is perpendicular to the longitudinal axis of the inspection gauge (400), and is used as a visual reference surface for visual inspection of the planarity of the dissector blade (310).

Thus, when the orientation of inspection gauge (400) is inverted with respect to the position shown in Figure 11, and then inserted into a dissector (300)  
20 until the inspection gauge can no longer be advanced, a visual inspection of the planarity of the dissector blade (310) can be made by the operator. A gap (420) is formed between the edge of the dissector blade (310) and the end surface (415) of the inspection body. A visual examination of gap (420) readily identifies whether the planarity of the dissector blade (310) is acceptable. Figure 11C shows an  
25 example of a dissector blade (310) which is substantially planar, and the gap (420) is seen to be substantially uniform across the diameter of end surface (415).

Figures 11D and 11E show examples of dissector blades which are somewhat out of planarity (about a one degree deflection upward and downward, respectively), but which would still be acceptable for use. Figures 11F and 11G  
30 show examples of dissector blades which are out of planarity by about a two

degree deflection upward and downward, respectively, which renders them unacceptable for use. The operator can readily distinguish these unacceptable examples from the marginally acceptable examples with a one degree deflection in the following ways. With regard to Figure 11F, the gap (415a) near the free end of dissector blade (310) is at least twice the distance of the gap (415b) near the spoke (310'). With regard to Figure 11G, the free end of the dissector blade (310) contacts the end surface (415) of the inspection gauge.

Figure 1 includes forceps (500) which are used to pick up and insert the implant/implants according to the present invention. Figure 12 shows a plan view of forceps (500) in the open position. Forceps (500) include a pair of handles (510) joined by a living hinge (520) which provides a biasing force to bias the handles (510) to the open position shown in Figure 12.

Figure 12A shows an enlarged detailed view of the tips (530) of the forceps in the closed position. The tips (530) each include a specially designed cutout portion (532). The cutout portions join in the closed position to form a geometric shaped space (534) that is specially designed to hold an implant ring or implant segment at a predetermined orientation to simplify the implantation of the ring or segment.

For example, the implant (536) held in space (534) in Figure 12 is maintained at an orientation angle  $\lambda$  of about  $34^\circ$ , which would be the intended angle of implantation of this particular implant. Thus, the forceps (500) are tailored to a specific implantation orientation. Only the specific example in the figures is limited to  $34^\circ$  however. The concept itself can be applied to any angle which the implant is desired to be maintained at during implantation, by changing the dimensions of the cutouts (532) which are also dependent upon the configuration of the implant itself.

The entirety of the forceps is preferably made of anodized titanium alloy (6 Al, 4V), but may be made of non-anodized titanium alloy, various stainless steels, and other metals and materials which are known to be biocompatible, sterilizable and relatively strong and durable.

Figure 13 shows a flow chart describing a method of placing an implant in a cornea according to the present invention. At step (600) the geometric center of the cornea is marked with a blunt instrument (e.g., a Sinsky hook) using an operating microscope for fixation and an 11 mm zone marker can be used to aid in locating the center point. A sterile marking pen may be used to enhance the mark. This center mark is used as the reference point throughout the surgical procedure. The specific surgical technique described herein is for purposes of example only, and may be slightly altered to provide the surgeon with flexibility during the corneal implant surgical procedure. The surgical instruments to be used during the procedure are illustrated in Figure 1. Prior to the use in the procedure, all surgical instruments in the sterile field are to be rinsed with sterile water and wiped using a lint-free instrument wipe.

At step (602), the contact surface (102) of the incision and placement marker (100) is marked, using a sterile marking pen, for example. Other non-toxic, biocompatible dyes which do not run may be alternatively used. The incision and placement marker (100) is next centered on the center mark created at the geometric center described above, by lining up the reticle (102) with the center mark. The contact surface (102), including surfaces (103), (104) and (105) are contacted lightly against the cornea, making an inked marking of where the radial incision will be made and where the segments will be positioned. A visual verification is made that the marks (103) are at least 1 mm from the limbus in all directions. If the marks (103) are too close to the limbus, re-marking of the geometric center of the cornea is required, to get closer to the actual geometric center.

A pachymetry measurement is made to determine the thickness of the corneal tissue at the incision site. Next, a calibrated, diamond knife is set to 0.430 mm (430 $\mu$ ) or 68% of the intraoperative pachymetry reading taken at the incision site. The diamond should either have an angled cutting edge of 15° or less, or have a rectangular blade of 1 mm width or less. Preferably, a recording of the integrity of the diamond blade tip and the inspection of the dissectors is made on a

surgical video, although this is not essential to the inventive method. Also, the actual knife setting is recorded on the surgical video for record keeping purposes.

At step (604), a radial incision is made by tracing to the outside edge of the incision mark, see Figure 10. The incision length may range from about 1.0 to 1.8 mm, and is preferably about 1.3 mm. Special care should be taken to ensure that the incision is kept approximately 1 mm away from the limbus. The incision area is then thoroughly irrigated with balanced salt solution after completing the incision. A Merocel® spear or equivalent is used to remove any loose epithelial cells and excess balanced salt solution from the edges of the incision. The epithelium may be rolled away from the incision edges.

The incision is again thoroughly irrigated with balanced salt solution prior to any instrument insertion. It is recommended that the surgeon increase the magnification of the microscope to enhance visualization during the next step. At step 606, a spreader tip (156) is inserted vertically down into the incision until it contacts the bottom of the incision. A blunt dissection or pocket is then created on one side of the base of the incision by carefully rotating the blade (160) of the instrument within a single stromal plane. The procedure is then repeated on the other side of the incision base. The resultant pockets should be at the same depth as the incision base, as wide as the full incision length, and extend to the full length of the spreader tip (156).

The corneal thickness gauges (250) may be used to estimate the depth for both pockets at step (608). If the pockets are not deep enough in the corneal stroma, make the incision slightly deeper with the diamond knife and create a second pocket at a deeper level with the spreader (150).

At step (610) the incision and placement marker(100) is indexed into the vacuum centering guide (VCG), and the reticle (106) is aligned with the center mark to center the VCG on the center mark. The VCG is then lowered to contact the sclera of the eye while maintaining centration, and then vacuum is slowly applied. As noted in the description above, proper placement of the VCG over the incision and placement marker (100), together with proper alignment of the

marker (100) on both the center mark and the actual incision, ensure that a window in the VCG is centered about the incision site. The vacuum should start in the range of 12-15 inches of Hg. Once a vacuum seal has been established, a confirmation that the VCG is properly placed is made, by checking centration. If the VCG is not properly positioned, the vacuum must be released, and step (610,) as described above, must be repeated. If the VCG is determined to be properly positioned, the vacuum is then slowly increased to 18-20 inches of Hg. It is recommended that the vacuum not exceed 22 inches of Hg. Next, the incision and placement marker (100) is removed from the VCG.

Every effort should be made to complete the channel dissection and to remove the VCG as quickly as possible in order to minimize the vacuum time. It is recommended that the vacuum time not exceed five minutes. While maintaining the position of the VCG, a counterclockwise (CCW) dissector (300) is inserted into the VCG at step (612). The dissector body (300) should be rotated until the tip of the dissector blade (310) is adjacent to the incision site. The counterclockwise glide (240) is inserted in the incision as shown in Figure 9C above, at least 1 mm into the pocket and the dissector tip is rotated under the foot (246) of the glide. Counterclockwise rotation of the dissector body (300) allows the dissector tip to enter the pocket underneath the glide (240). The dissector blade (310) is then advanced approximately 1 mm to 2 mm, then stopped. The glide (240) is removed while leaving the dissector tip in position in the pocket.

While holding the VCG vertically with one hand, the operator rotates the dissector (330) counterclockwise from the incision to create a stromal channel support. Rotation of the dissector (330) in a counterclockwise direction is continued until the support spoke (310') of the dissector blade (310) contacts the incision edge. Then the dissector blade (310) is removed from the channel by rotating the dissector body (330) clockwise until the dissector tip exits the channel, and the dissector (330) is then removed from the VCG.

While maintaining the position of the VCG, the clockwise (CW) dissector (330) is inserted into the VCG. The dissector body (330) is rotated until the tip of

the dissector is adjacent to the incision site. Next, the clockwise (CW) glide (240) is inserted at least 1 mm into the opposite pocket and the dissector tip is rotated under the foot (246) of the glide (240). Clockwise rotation of the dissector body (330) drives the dissector tip into the pocket. The dissector tip should be inserted underneath the glide foot (246) to enter the pocket. The glide blade (310) is next advanced approximately 1 mm to 2 mm, then stopped in its position. The glide (240) is removed while leaving the dissector tip in position in the pocket.

While holding the VCG vertically with one hand, the operator rotates the dissector (330) clockwise from the incision to create a second stromal channel.

The clockwise rotation of the dissector (330) is continued until the support spoke (310') of the dissector blade (310) contacts the incision edge. Then the dissector blade (310) is removed from the channel by rotating the dissector body (330) counterclockwise until the dissector tip exits the channel. The dissector (330) is then removed from the VCG.

The vacuum is next released and the VCG is removed from the eye. Any stromal debris from the incision site is removed and the incision area is again thoroughly irrigated, using balanced salt solution, prior to insertion of each segment into the stromal channel. Optionally, a small amount of Celluvisc® or an equivalent lubricating agent may be applied to the surface of the cornea, to avoid direct contact of the segments with the epithelium, although this is not preferred.

Each segment is picked up using forceps (500) as described above. The leading end of each segment is fed, into the stromal channel from the incision at step (612). One segment is rotated clockwise and the second segment is rotated counterclockwise. The segments have an anterior/posterior orientation. The segment should be placed in the stroma concave side down, such that the cone angle of the segment is most closely matched with the curvature of the cornea.

Using forceps (500) or a Sinsky Hook, the segments are manipulated into the desired location within the channel, aligning the outside edge of the segments with the ink markings (123), and the leading ends of the segments with ink markings (125) created by the incision and placement marker at Step (602).

Again any stromal debris is removed from the incision area, and the incision area is thoroughly irrigated with balanced salt solution. The tissue edges of the incision are gently approximated to close at step (616), and the incision may be closed with one to two interrupted sutures using an ophthalmic suture,  
5 preferably 10-0 or 11-0 nylon or equivalent. The suture depth should be to the level of the stromal pocket. Care should be taken to avoid microperforation by the suture needle. If two sutures are placed, the sutures should trisect the incision line from the superior and inferior aspects of the incision to insure apposition of the anterior edges of the incision.

10 The anterior incision edges must be opposed to prevent epithelial cells from entering the incision. Care should be taken to ensure that tension across the sutures is evenly applied, however overtightening of the sutures should be avoided as this may induce astigmatism. A high magnification image of the final placement of the ICRS product is recorded at the completion of the procedure.

15 Other modifications to the embodiments described above will be apparent to those skilled in the art. The disclosures of all prior art references described above are incorporated herein by reference. For example, the dimensions in the drawings are merely provided for example.

CLAIMS

5           1. An ocular marker comprising a support having an end portion, said end portion, said end portion including a marking surface adapted to form a mark on the surface of an eye.

          2. The marker of claim 1, wherein said marking surface comprises a generally I-beam shaped portion.

10           3. The marker of claim 2, wherein said marking surface further comprises generally crescent shaped portions.

          4. The marker of claim 3, wherein said generally crescent shaped portions further comprise end marks which form a distinctive break with the crescent  
15           shape.

          5. The marker of claim 1, wherein said support comprises a substantially cylindrical main body.

20           6. The marker of claim 5, further comprising wherein a pin extending from an outer wall of said substantially cylindrical main body.

          7. The marker of claim 5, further comprising a reticle centrally aligned with a longitudinal axis of said substantially cylindrical main body.

25           8. A corneal spreader comprising a handle having a first diameter or thickness, an extension extending from said handle and having a second diameter which is less than said first diameter or thickness, and a tip extending from said extension at an obtuse angle.

9. The spreader of claim 8, wherein said tip is substantially flat and relatively wide and thin.

5           10. The spreader of claim 8, wherein said tip comprises a tip end that is substantially rounded and blunt.

11. The spreader of claim 10, wherein said tip end is substantially hemispherically shaped.

10

12. The spreader of claim 10, wherein said tip further comprises tip sides extending from said tip end, wherein said tip sides are sharper than said tip end.

13. A glide comprising:

15

a glide handle;

a glide blade extending from said glide handle; and

a glide foot extending from said glide blade and positioned at an obtuse angle with respect to a longitudinal axis of said glide handle.

20

14. The glide of claim 13, wherein said glide foot is substantially flat.

15. The glide of claim 13, further comprising an additional glide which is a mirror image of the glide of claim 13.

25

16. The glide of claim 13, wherein said glide foot extends in a direction perpendicular to the longitudinal axis of the glide handle, by a length which is greater than or equal to a width of said glide blade at a location where said glide blade meets said glide

17. The glide of claim 13, further comprising:

a threaded rod extending through said handle and having a collet at one end thereof, wherein said threaded rod is releasably mounted to said handle to receive said glide blade in said collet.

5

18. A field dissector inspection gauge, comprising:

a main body adapted to closely fit an inside diameter of a dissector tool;

a post extending from one end of said main body, said post having a diameter which is smaller than a diameter of said main body, wherein said post is dimensioned and adapted to extend through an interior circumference of a dissector blade of the dissector tool.

10

19. The inspection gauge of claim 18, further comprising:

a fence substantially following the contour of a portion of said post and adapted to closely contour an outer edge of the dissector blade.

15

20. The inspection gauge of claim 19, wherein said fence and said post form an annular recess therebetween.

20

21. The inspection gauge of claim 20, wherein said fence forms a substantially semi-cylindrical arcuate section.

22. The inspection gauge of claim 18, further comprising:

a second post extending from an end of said main body opposite said first post, said second post having a diameter which is smaller than said diameter of said main body, but larger than said diameter of said post extending from said one end.

25

23. The inspection gauge of claim 22, wherein said second post is chamfered at a free end thereof, said chamfered end being adapted to abut a supporting spoke of said dissecting blade for inspection of planarity of said dissecting blade.

5

24. Forceps, comprising:

first and second handles having first and second tips extending therefrom, respectively;

10

each of said first and second tips comprising a cut out, wherein said cut outs are adapted to form a space having a predetermined shape, upon closing said first and second tips together.

15

25. The forceps of claim 24, wherein said predetermined shape is designed to hold an implant at a predetermined acute angle with respect to a perpendicular to a longitudinal axis of said forceps.

26. A kit for performing corneal surgery, comprising:

an ocular marker as recited in claim 1;

a corneal spreader as recited in claim 8;

20

at least one glide as recited in claim 13; and

a field dissector inspection gauge as recited in claim 18.

27. The kit of claim 26, further comprising:

forceps as recited in claim 24.

25

28. The kit of claim 26, further comprising:

a pair of glides as recited in claim 15.

29. A method of using ophthalmological instruments, comprising:

centering an incision and placement marker on an eye;  
marking an incision mark on the eye with the incision and placement  
marker;  
removing the incision and placement marker from the eye;  
5 making an incision in the corneal tissue of the eye in the location of the  
incision mark;  
forming a pocket intrastromally at the cite of the incision, using a  
corneal spreader;  
forming an intrastromal channel using a dissector; and  
10 inserting a corneal implant into the intrastromal channel.

30. The method of claim 29, further comprising  
inserting a glide in the pocket to facilitate insertion of the dissector for  
forming the instrastromal channel.

15 31. The method of claim 29, further comprising:  
picking up the corneal implant with forceps designed to maintain the  
corneal implant at a predetermined angle with respect to the longitudinal axis of  
the forceps.

20 32. The method of claim 29, further comprising:  
checking the planarity and concentricity of the dissector, prior to use,  
with a field dissector inspection gauge.

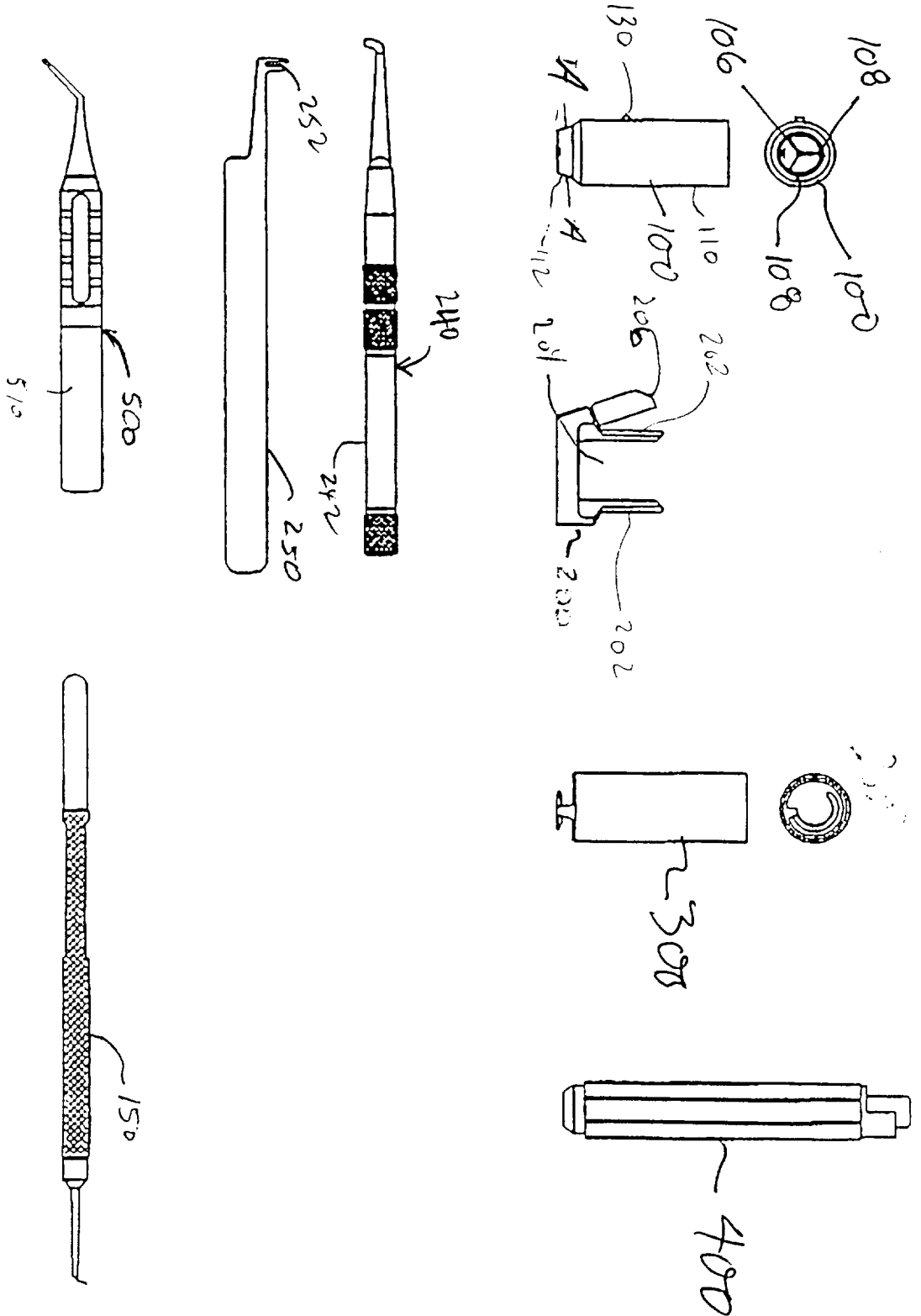

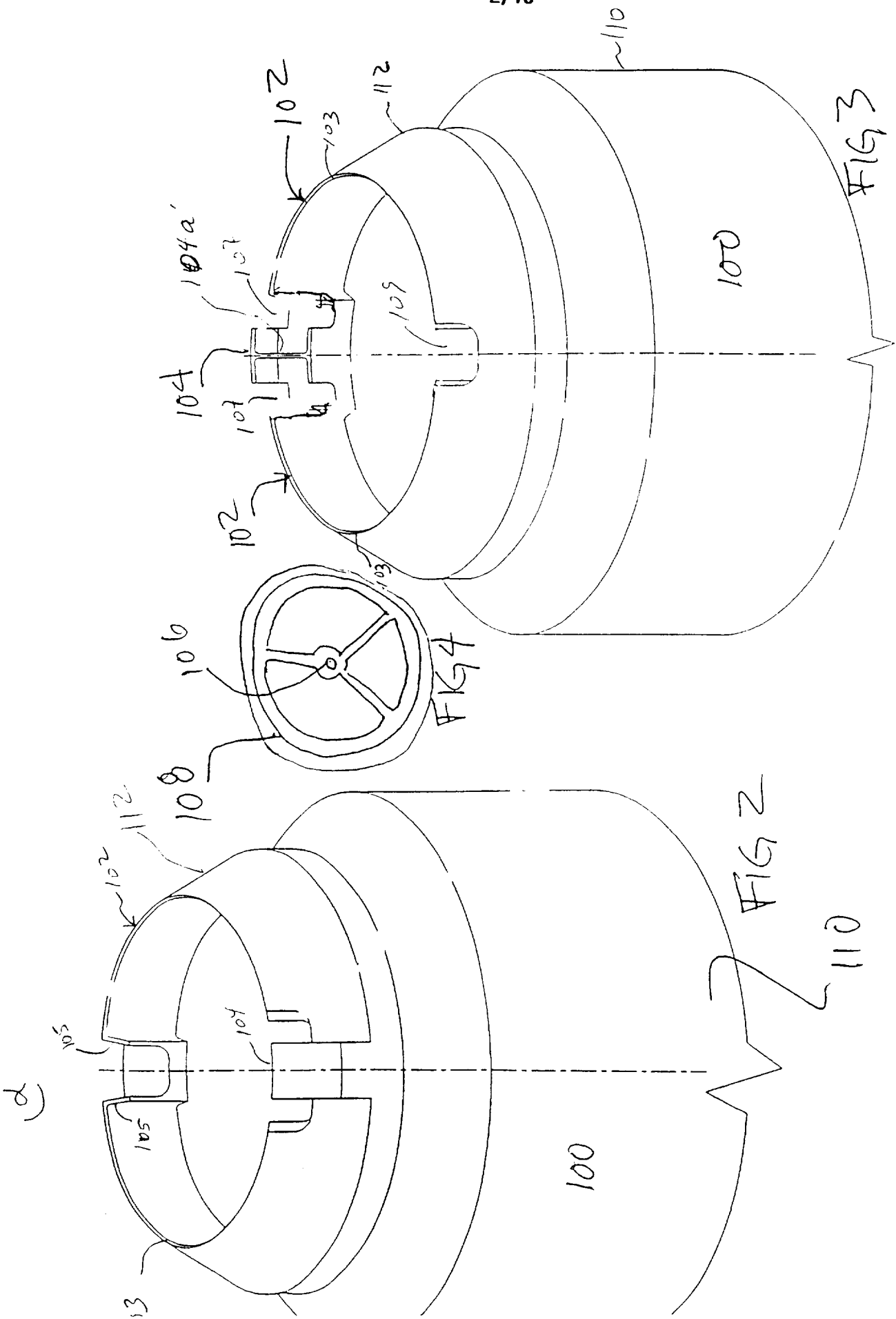

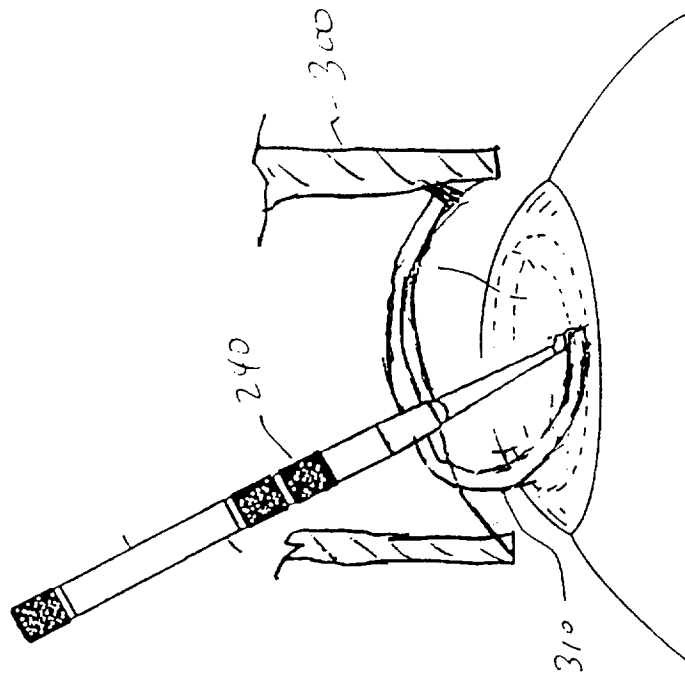
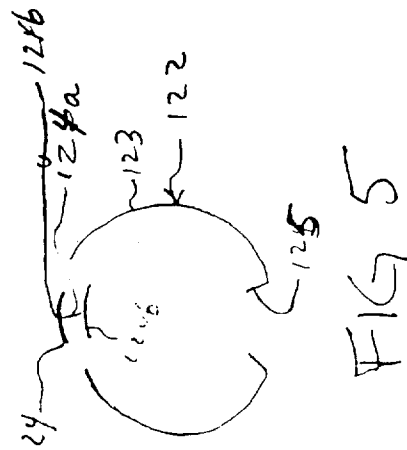

Figure 9C

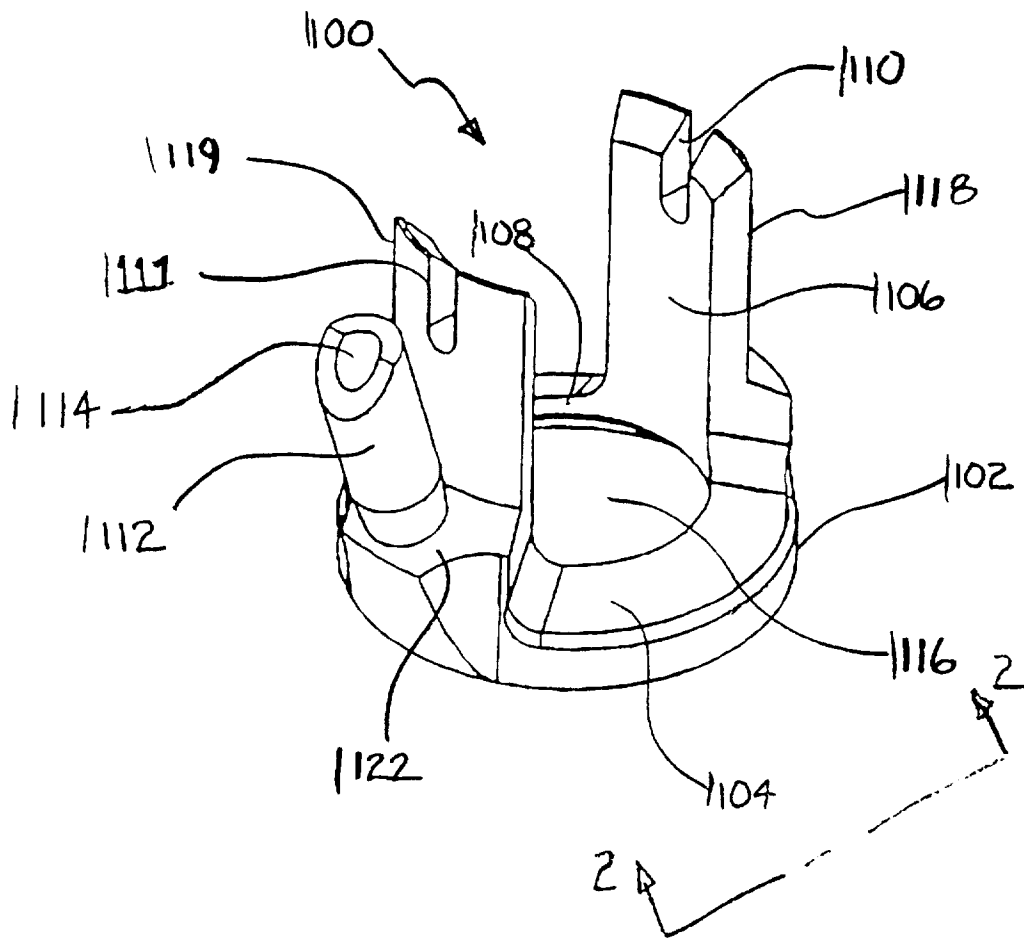

FIGURE 6

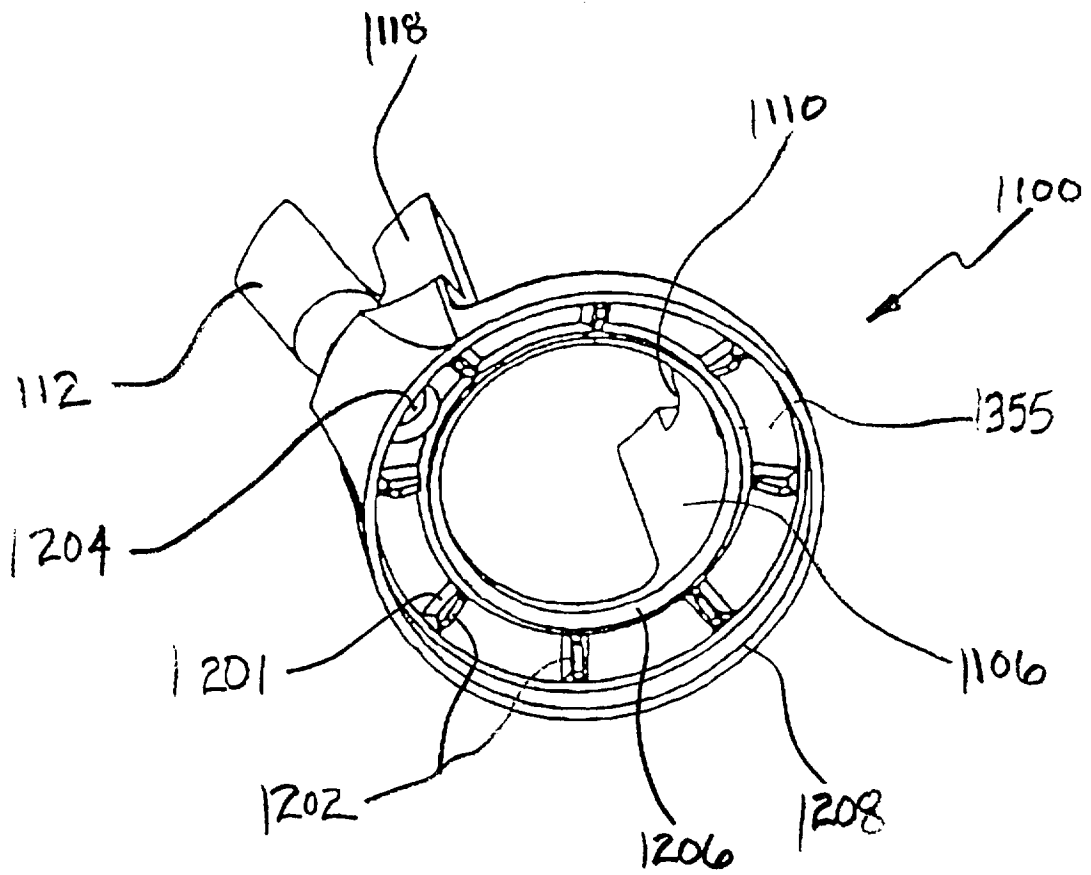

FIGURE 6A

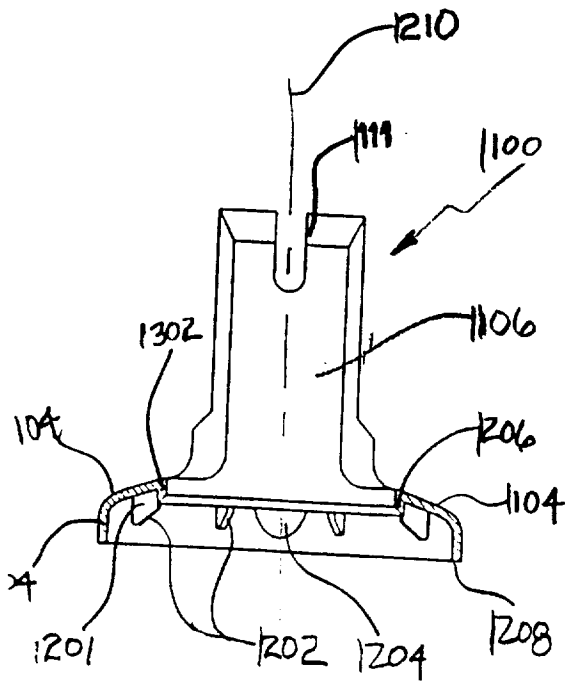

FIGURE 6D

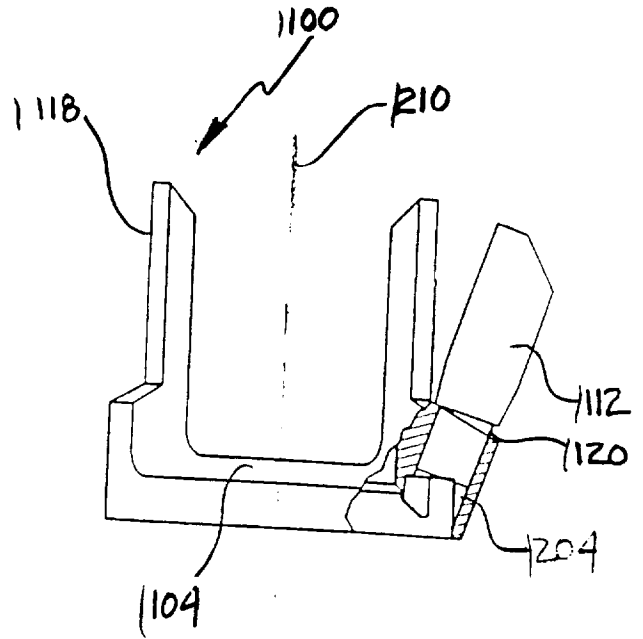

FIGURE 6C

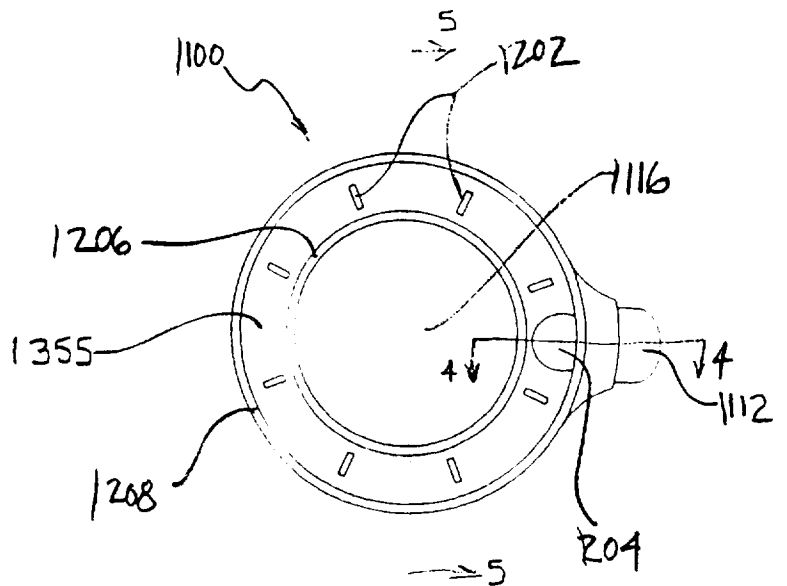

FIGURE 6B

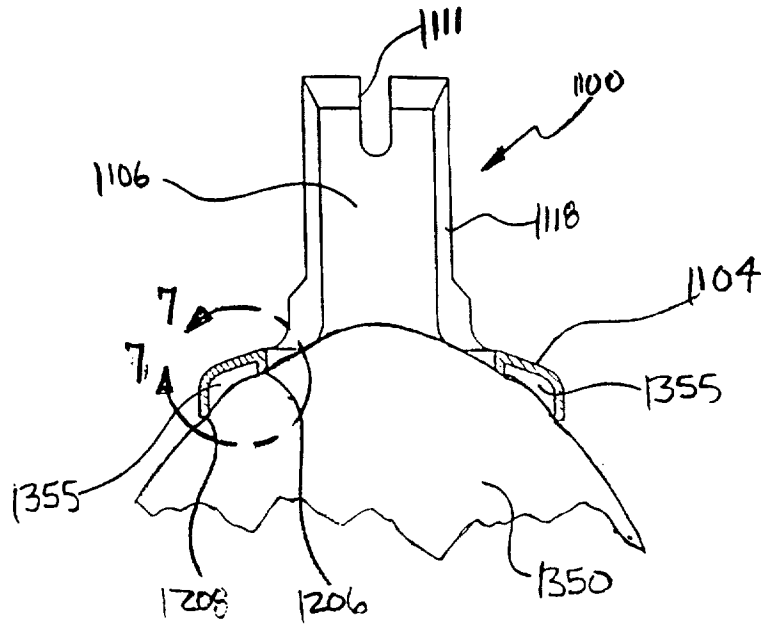

FIGURE 6E

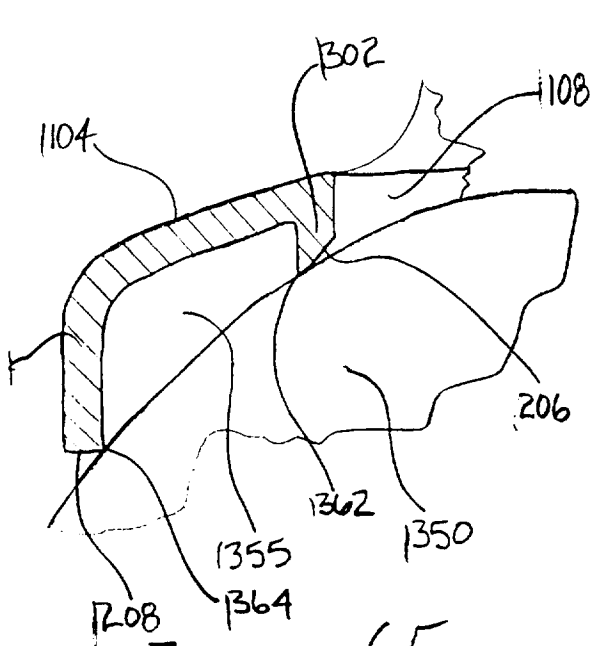

FIGURE 6F

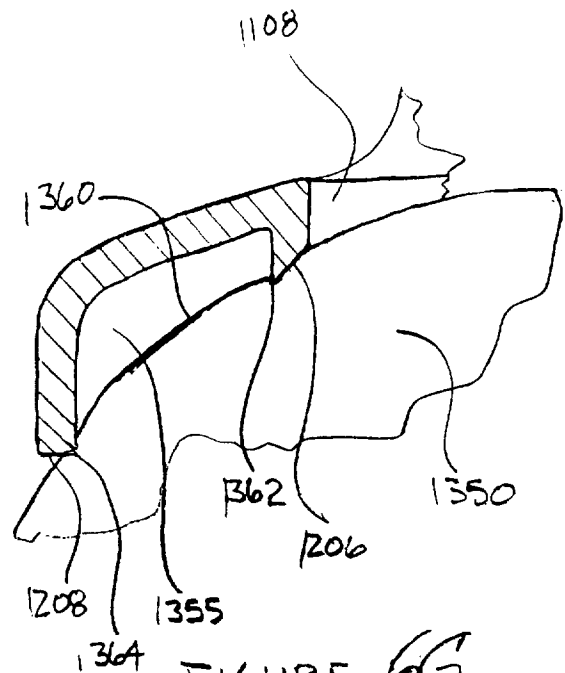

FIGURE 6G

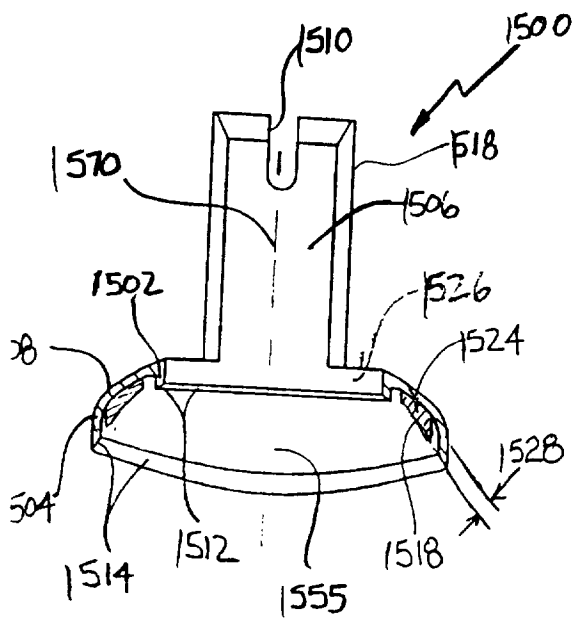

FIGURE 6J

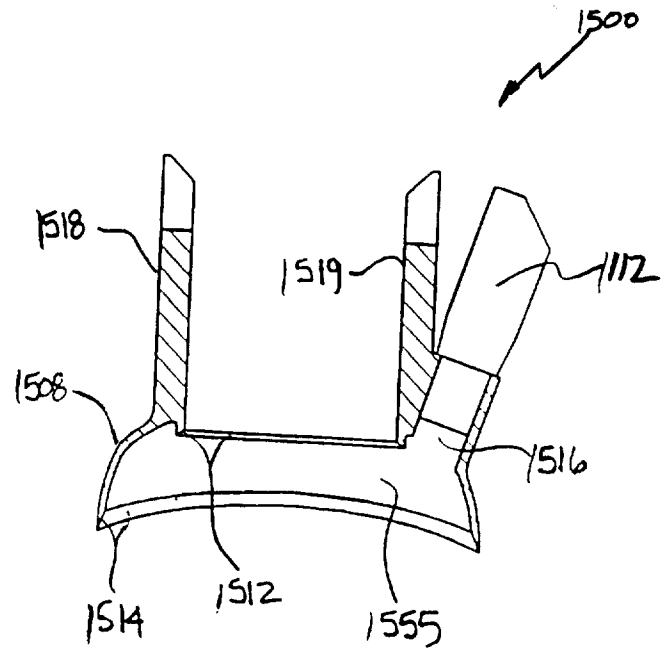

FIGURE 6I

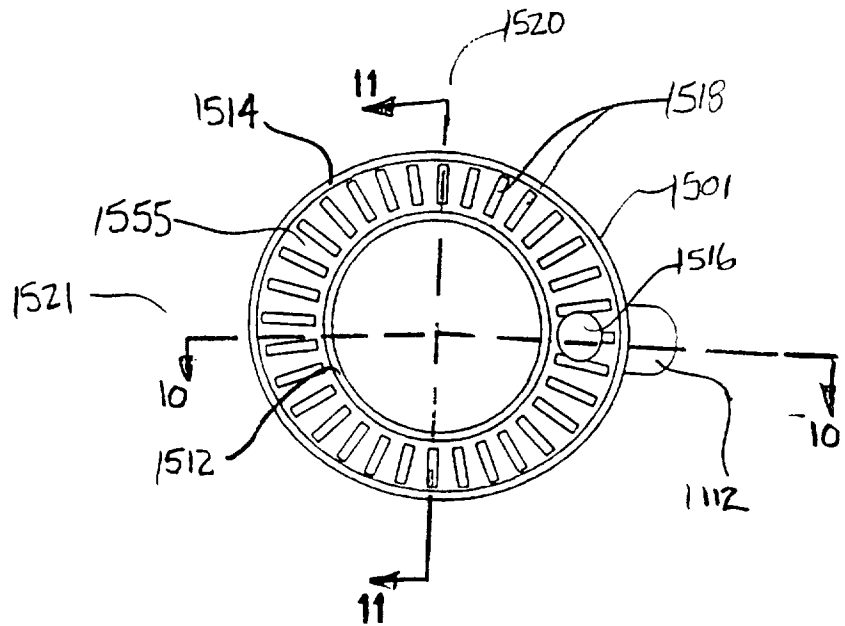

FIGURE 6H

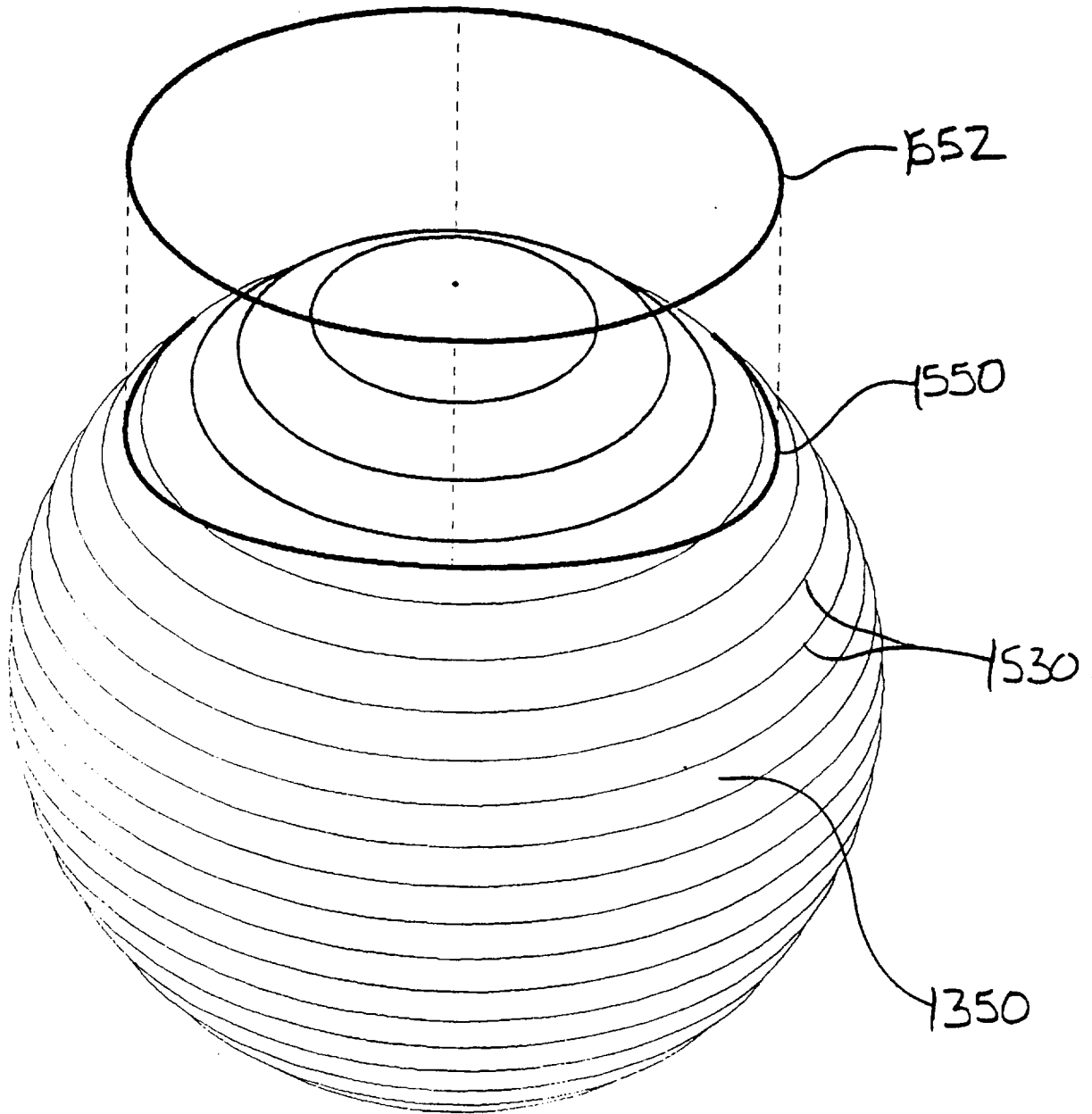

FIGURE 6E

10/16

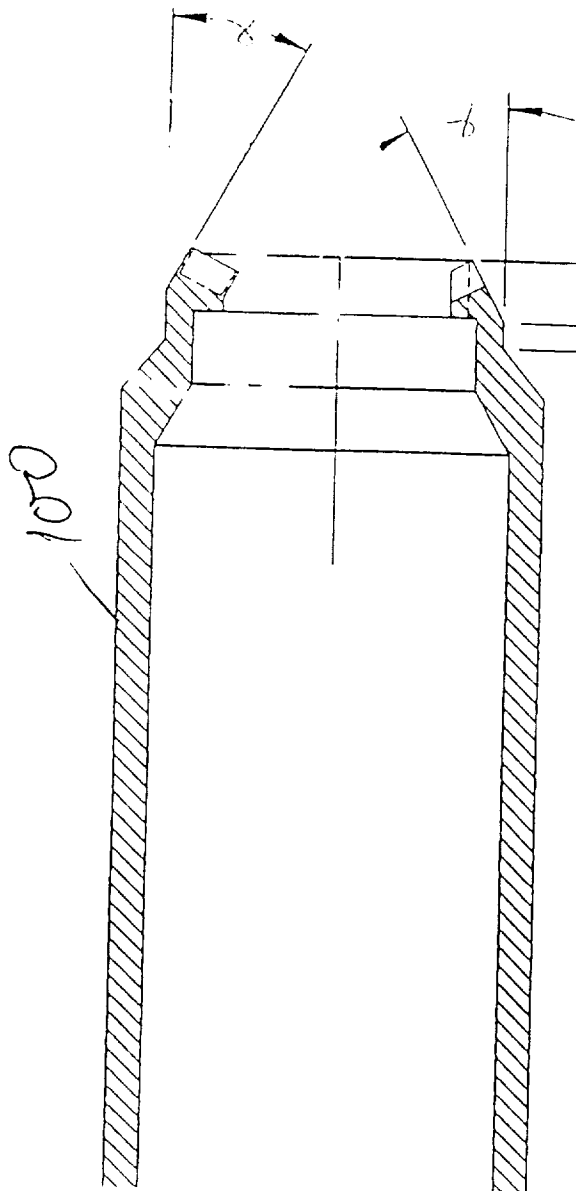
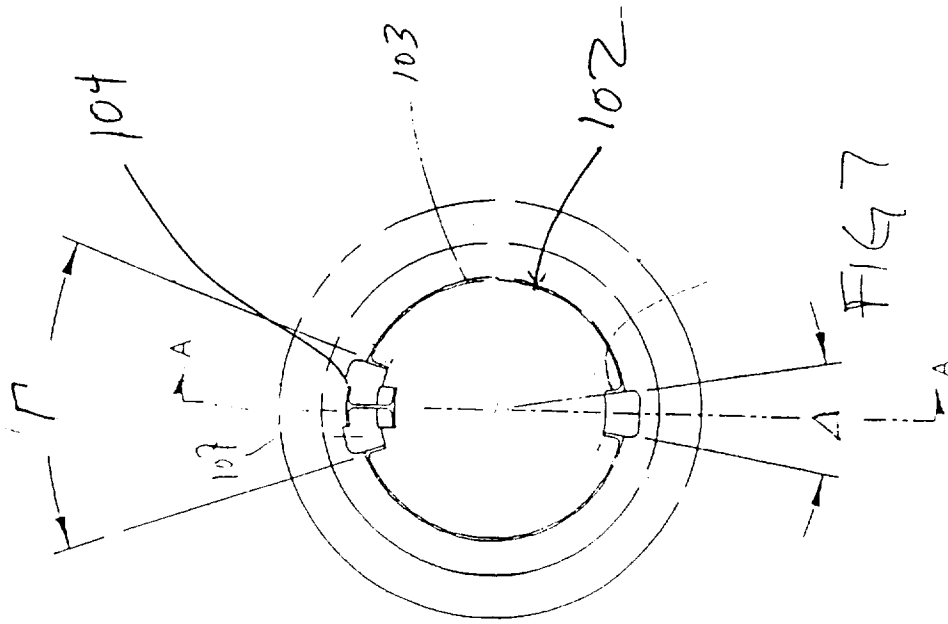

FIG 7A

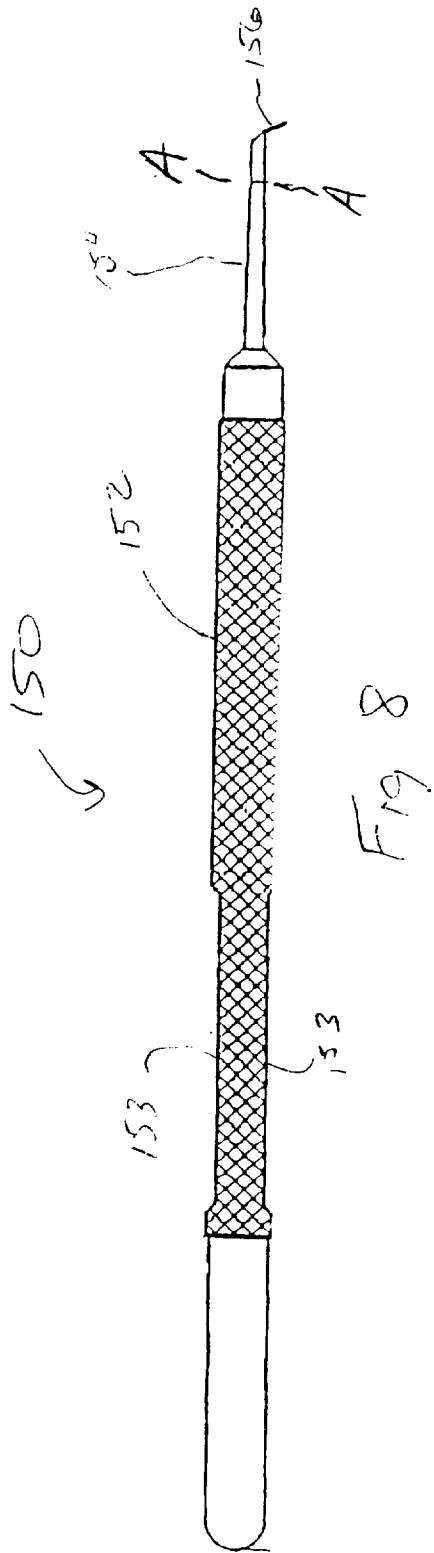

Fig 8

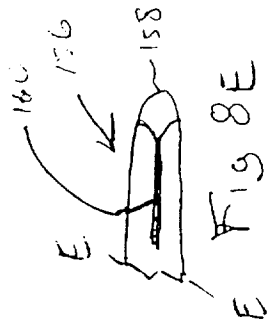

FIG 8E

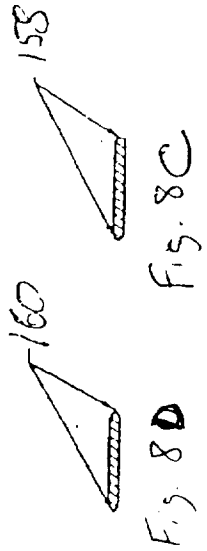

FIG 8C  
FIG 8D

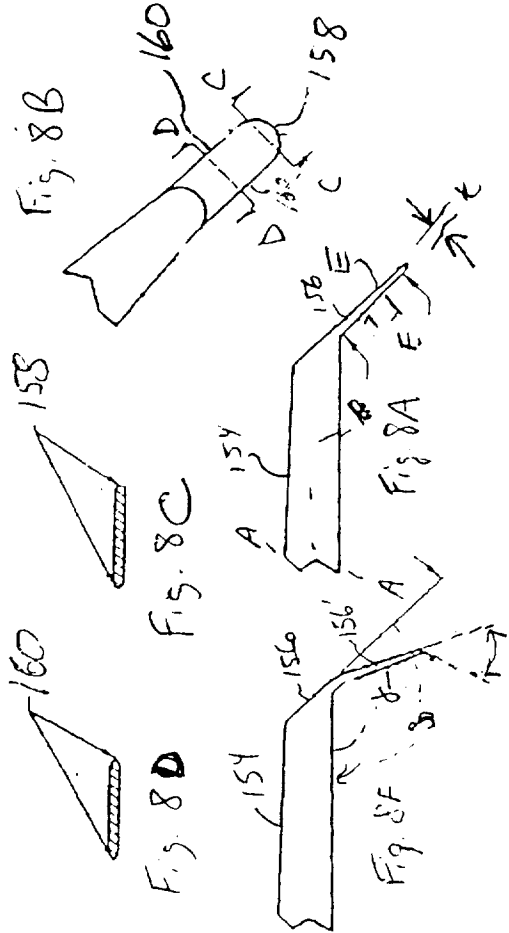

Fig. 8B

Fig 8A

Fig 8E

Fig 8F

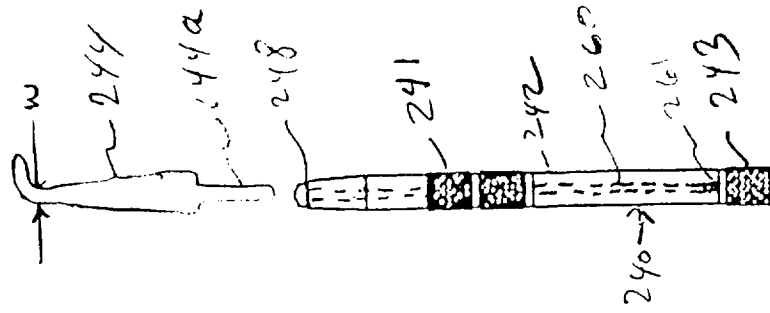

Figure 9

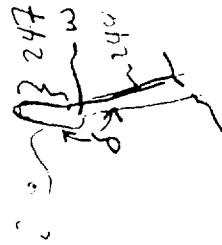

Figure 9D

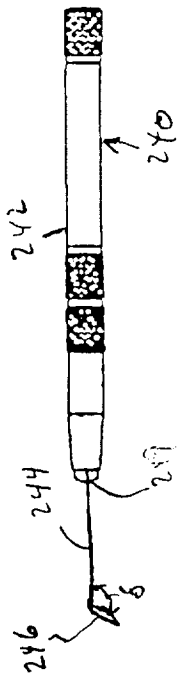

Figure 9A

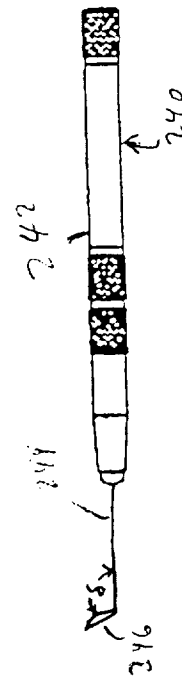

Figure 9B

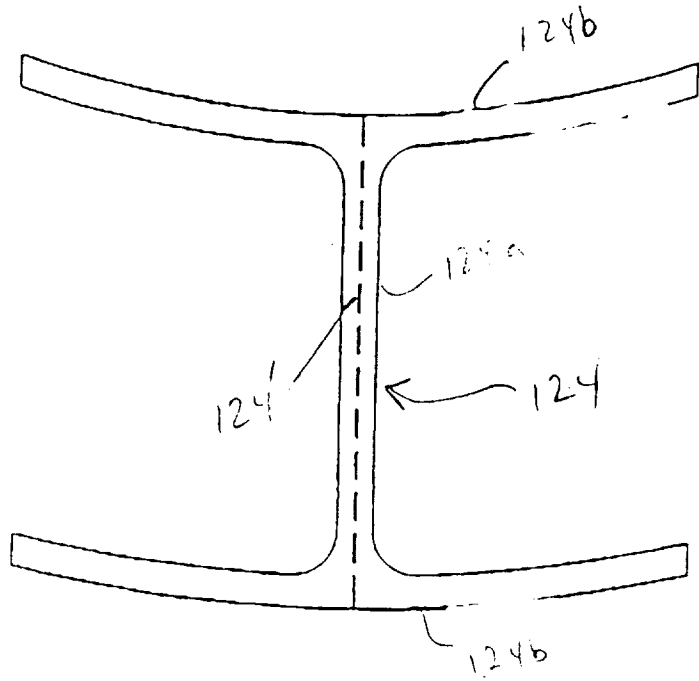

FIGURE 10

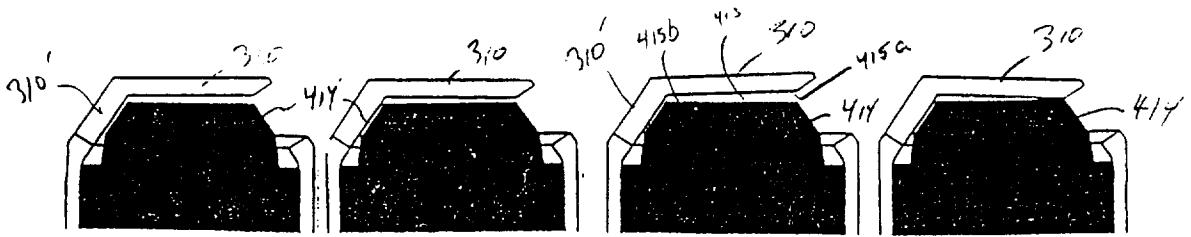
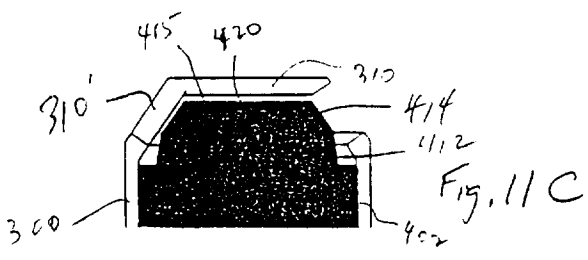
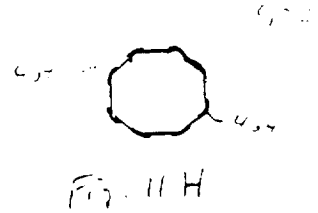
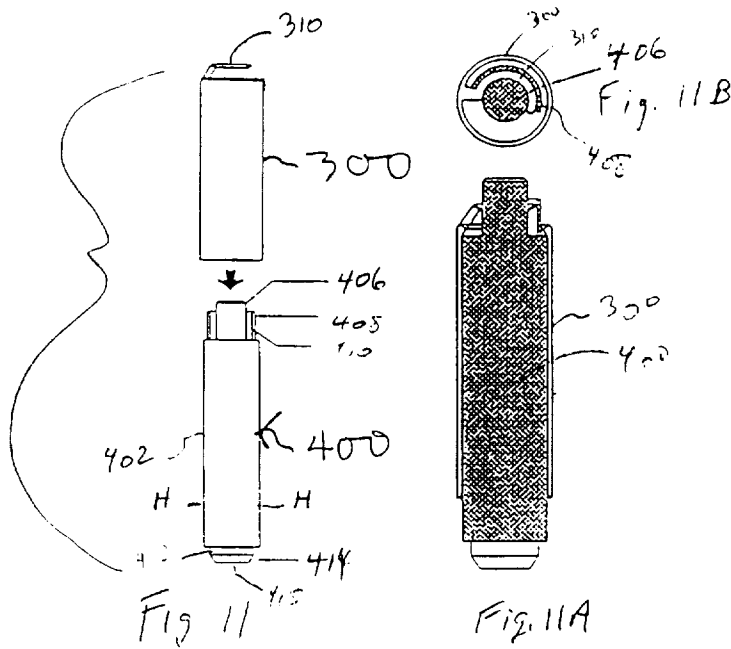
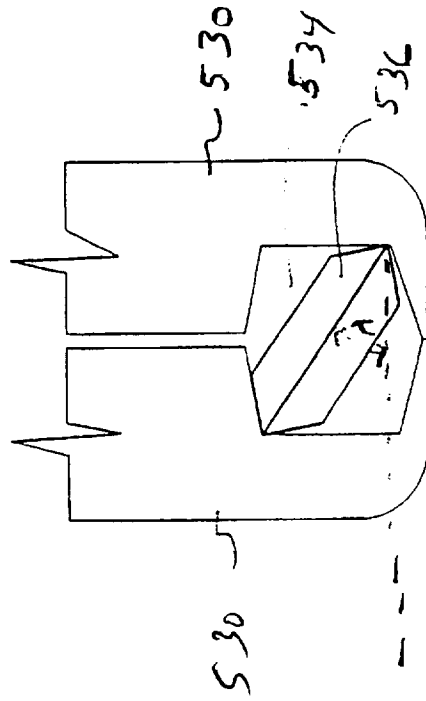
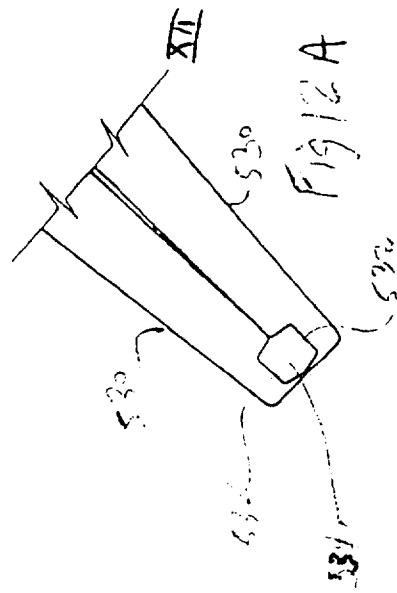
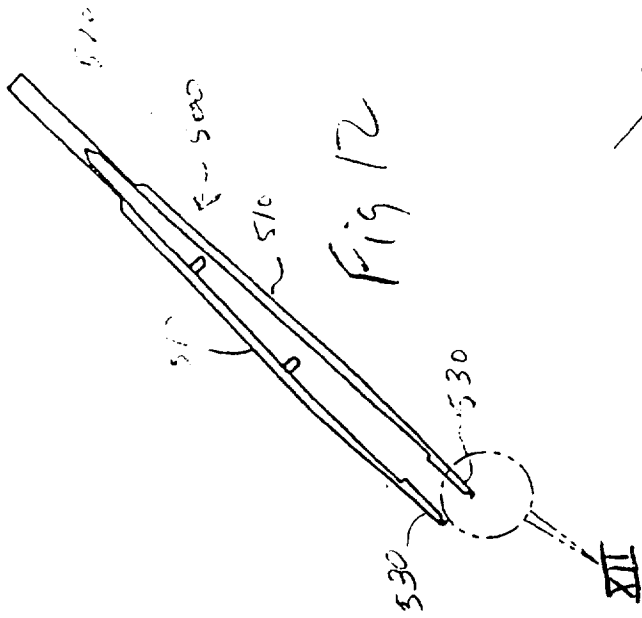

Fig. 11D

Fig. 11E

Fig. 11F

Fig. 11G



Surgical Procedure Flow Chart

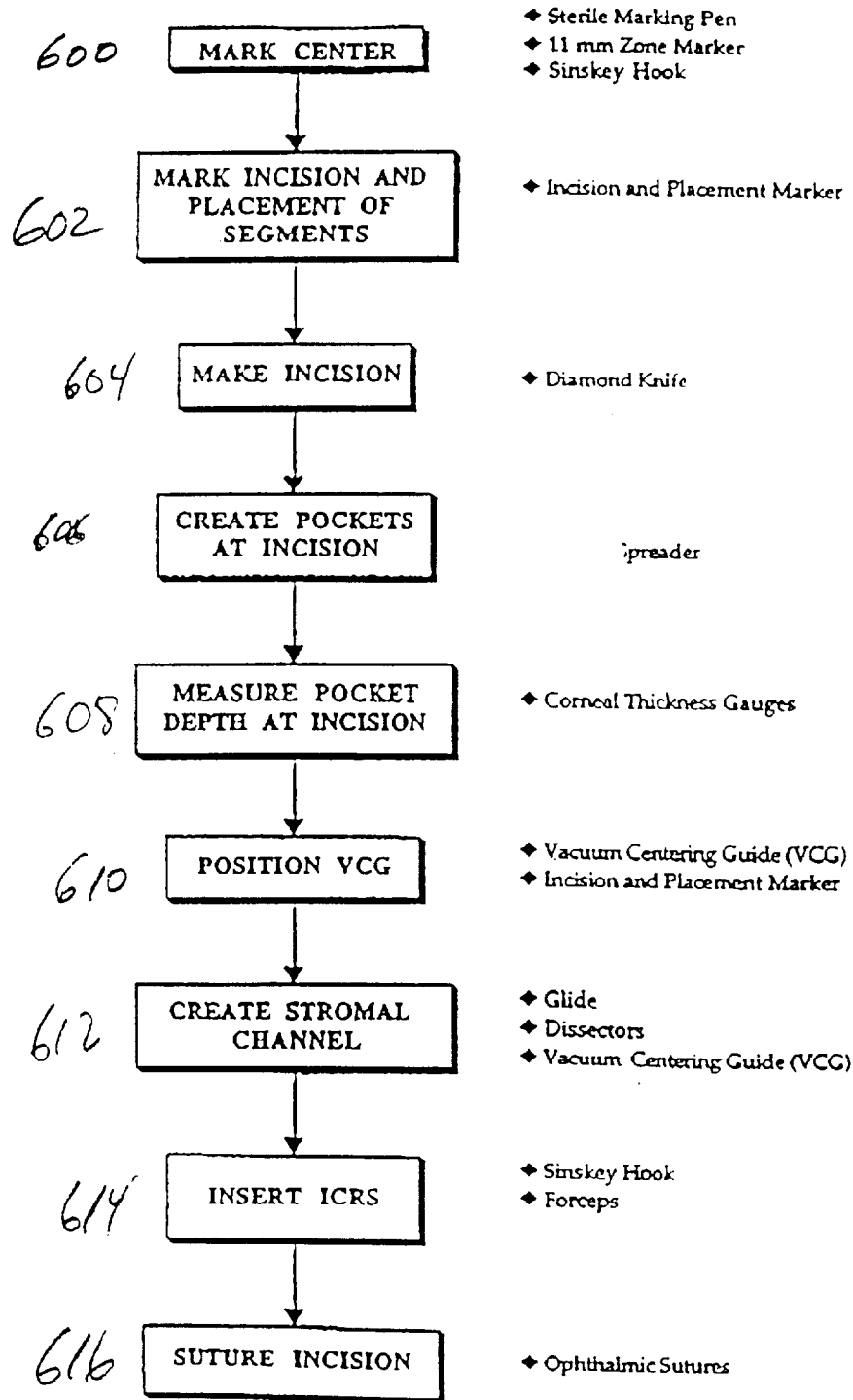

FIG. 13